

aerospace
climate control
electromechanical
filtration
fluid & gas handling
hydraulics
pneumatics
process control
sealing & shielding

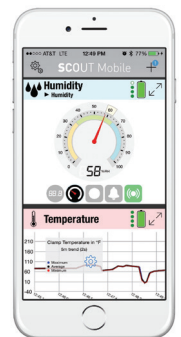

Condition Monitoring for Predictive Maintenance SensoNODE™ Blue and SCOUT™ Mobile Sensors, Software, and Accessories Catalog 3864 USA | September 2015



ENGINEERING YOUR SUCCESS.

Quick Coupling Division Locations



Minneapolis, MN



Grantsburg, WI



Chetek, WI



Union City, PA



Sunnyvale, CA

WARNING

FAILURE OR IMPROPER SELECTION OR IMPROPER USE OF THE PRODUCTS DESCRIBED HEREIN OR RELATED ITEMS CAN CAUSE DEATH, PERSONAL INJURY AND PROPERTY DAMAGE.

- This document and other information from Parker Hannifin Corporation, its subsidiaries and authorized distributors provide product or system options for further investigation by users having technical expertise.
- The user, through its own analysis and testing, is solely responsible for making the final selection of the system and components and assuring that all performance, endurance, maintenance, safety and warning requirements of the application are met. The user must analyze all aspects of the application, follow applicable industry standards, and follow the information concerning the product in the current product catalog and in any other materials provided from Parker or its subsidiaries or authorized distributors.
- To the extent that Parker or its subsidiaries or authorized distributors provide component or system options based upon data or specifications provided by the user, the user is responsible for determining that such data and specifications are suitable and sufficient for all applications and reasonably foreseeable uses of the components or systems.

Offer of Sale

The items described in this document are hereby offered for sale by Parker Hannifin Corporation, its subsidiaries or its authorized distributors. This offer and its acceptance are governed by the provisions stated in the "Offer of Sale."

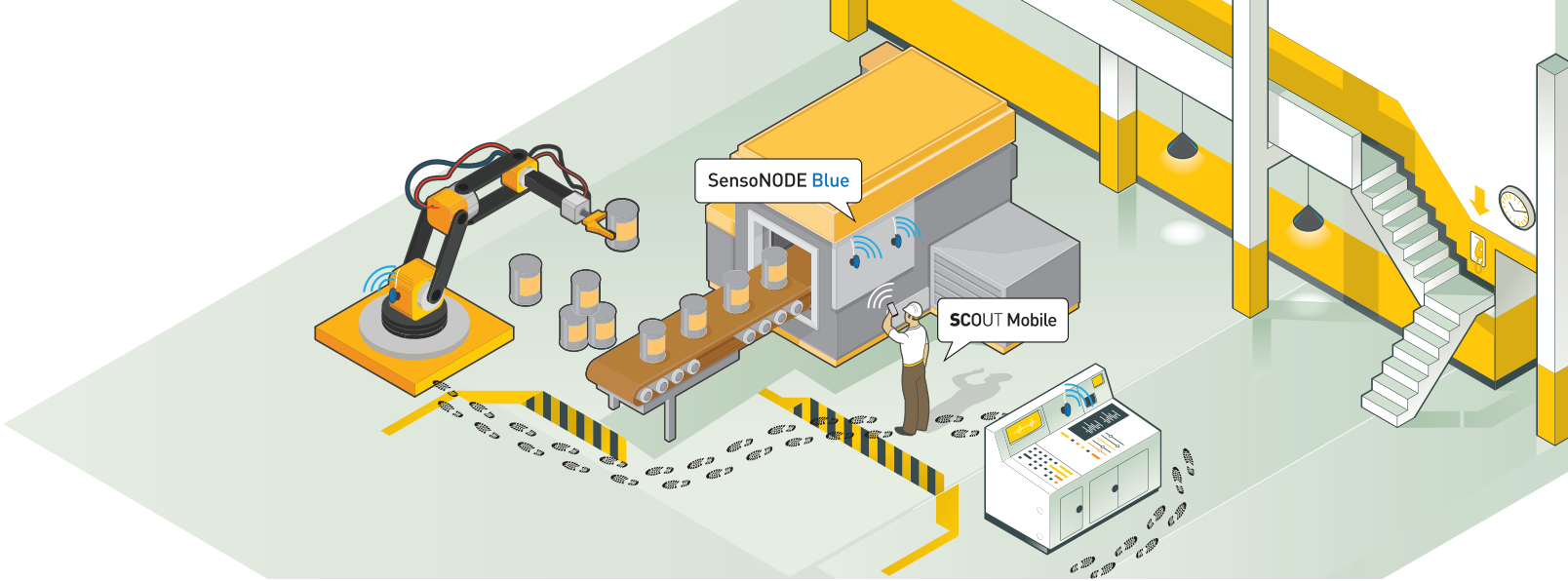

Table of Contents

Introduction	4-5
Pressure Sensors	6-7
Temperature Sensors	8-9
Humidity Sensors.....	10-11
Accessories	12-13
SCOUT Mobile Software.....	14-15

Condition Monitoring for Predictive Maintenance

The Industrial Internet of Things (IIoT) is changing the way manufacturing works, and your company can set the pace. As global competitiveness drives companies to find new ways to improve efficiency and product quality, not reviewing your processes and plants for opportunities with IIoT leaves your company standing still while others move forward.

Traditionally, improving efficiency means monitoring certain pieces of equipment or processes one at a time and keeping track of their conditions. This can be an inaccurate, labor-intensive process that takes up valuable man-hours and creates potentially dangerous situations for workers...in short; it costs companies time and money.

Parker's approach creates new possibilities with IIoT-enabled assets, delivering predictive analytics that drive optimal tactical, operational, and strategic decisions, leading to maximum uptime. Through wireless connectivity, you have access to both real-time and historical data for a comprehensive picture of their system's performance. Tracking consistent, accurate analytics allows for:

- Process improvement
- Process control
- Labor efficiency
- Flexibility of operation
- Improved quality
- Reduced maintenance
- Reduced inventory
- Process automation

Condition monitoring helps companies move products to market faster, and grow their business in ways they never thought possible! Through wireless connectivity, companies can respond to alerts that require immediate action to keep operations running smoothly, monitor their processes and fine-tune them for optimal throughput and product quality.

SensoNODE™ Blue Sensors & SCOUT™ Mobile Software

Parker's SensoNODE Blue Sensors and SCOUT Mobile software deliver an IIoT solution that provides an advanced condition monitoring for predictive maintenance across multiple applications and industries. The SensoNODE Bluetooth-powered sensors catch performance fluctuations and transmit them to SCOUT software, which records the data in both real-time and historic trends.

By monitoring assets and tracking data, users can employ predictive maintenance routines that allow them to address even the smallest issue before it snowballs into a serious problem. This allows users to:

- Identify issues before they escalate
- Reduce downtime
- Decrease maintenance costs
- Avoid dangerous situations
- Improve labor efficiency
- Record better analytics for better decision-making

SensoNODE Blue is Parker's series of Bluetooth-powered sensors. Compact, energy-efficient, and wireless, they are designed to provide a simple solution for portable and diagnostic applications with mobile devices. SensoNODE monitors assets for changes in pressure, temperature, and humidity to help predict problems and prevent downtime.

Why Blue?

- Consistent and accurate readings for Pressure, Temperature, and Humidity
- Diagnostics mode to collect streams of data for analysis
- Beacon mode gives measurements and charts to any user within range
- Easy wireless connection process
- No power supply needed
- Compact, lightweight design
- Robust use in harsh environments
- LED indicator aids in identifying sensor status
- Each sensor is uniquely identifiable for association with assets or processes
- Remote monitoring with Bluetooth® Smart Technology, so no special device is required to read the information

SCOUT Mobile software allows users to connect their mobile devices to the network and receive the diagnostic data and analytics transmitted by SensoNODE sensors. SCOUT Mobile compiles the data and presents it in a way that makes sense to a user's operation, allowing them to track data in real-time and historic trends, and receive user-defined alerts for unexpected condition changes that may damage assets.

Why SCOUT?





- Automatic alert to system events
- Wireless monitoring
- Lower energy costs
- Reduced maintenance
- Address issues before they cause problems
- Real-time and historic trends for each sensor
- Compatible with most mobile devices
- Easy-to-use interface



Features:

- For commonly used pressures with the ranges of (0-150 psi, 0-1500 psi, 0-3625 psi, 0-5800 psi, 0-8700 psi)
[10 bar, 100 bar, 250 bar, 400 bar, 600 bar]
- User definable measurement units (psi/bar) for convenient and familiar data readings
- Ports: MNPT, SAE, couplings (push-button, sleeve operated, EMA3) to make plumbing and connecting easier and faster
- Corrosion resistant materials for challenging environments
- Sensor also provides temperature values.
- User selectable scan and transmit rates (mode dependent). Currently 1,2,5, and 10 seconds. Refer to SCOUT Mobile for the up to date capabilities and modalities.

Sensor Technical Data

					
Body Seals	Fluorocarbon	Fluorocarbon	Fluorocarbon	Fluorocarbon	Fluorocarbon
Housing Material	Polycarbonate	Polycarbonate	Polycarbonate	Polycarbonate	Polycarbonate
Port	1/4" Male NPT	-4 SAE	-4 SAE	-4 SAE	-4 SAE
Wetted Parts Material	17-4 Stainless	17-4 Stainless	17-4 Stainless	17-4 Stainless	17-4 Stainless
Measurement Range (pressure)	0-150 psi [10 bar]	0-1500 psi [100 bar]	0-3625 psi [250 bar]	0-5800 psi [400 bar]	0-8700 psi [600 bar]
Measurement Range (temperature)	-40°F to 230°F [-40°C to 110°C]	-40°F to 230°F [-40°C to 110°C]	-40°F to 230°F [-40°C to 110°C]	-40°F to 230°F [-40°C to 110°C]	-40°F to 230°F [-40°C to 110°C]
Max. Overload Pressure	225 psi	2250 psi	5440 psi	8700 psi	13,050 psi
Burst Pressure	4x	4x	4x	4x	4x
Accuracy (BFSL)[-40°C to 85°C]	0.75%	0.75%	0.75%	0.75%	0.75%
Resolution	0.1 psi [.006 bar]	0.1 psi [.006 bar]	0.1 psi [.006 bar]	0.1 psi [.006 bar]	0.1 psi [.006 bar]
Scan and Transmit Rate	User Selectable	User Selectable	User Selectable	User Selectable	User Selectable
Total Error Band (full scale)	2%	2%	2%	2%	2%
Ambient Temperature (battery limited)	-4°F to 167°F [-20°C to 75°C]	-4°F to 167°F [-20°C to 75°C]	-4°F to 167°F [-20°C to 75°C]	-4°F to 167°F [-20°C to 75°C]	-4°F to 167°F [-20°C to 75°C]
Fluid Media Temperature Range	-40°F to 185°F [-40°C to 85°C]	-40°F to 185°F [-40°C to 85°C]	-40°F to 185°F [-40°C to 85°C]	-40°F to 185°F [-40°C to 85°C]	-40°F to 185°F [-40°C to 85°C]
Full Range Life Cycles	> 1 million	> 1 million	> 1 million	> 1 million	> 1 million
Certifications	FCC, IC, CE*	FCC, IC, CE*	FCC, IC, CE*	FCC, IC, CE*	FCC, IC, CE*
Battery (Panasonic is recommended brand)	CR123A	CR123A	CR123A	CR123A	CR123A
IP Rating	IP65	IP65	IP65	IP65	IP65

Note: Consult factory for other port options and pressure ratings.

*CE approval in process, estimated approval Jan 1, 2016.



SensoNODE™ Blue

Pressure

Pressure Sensors

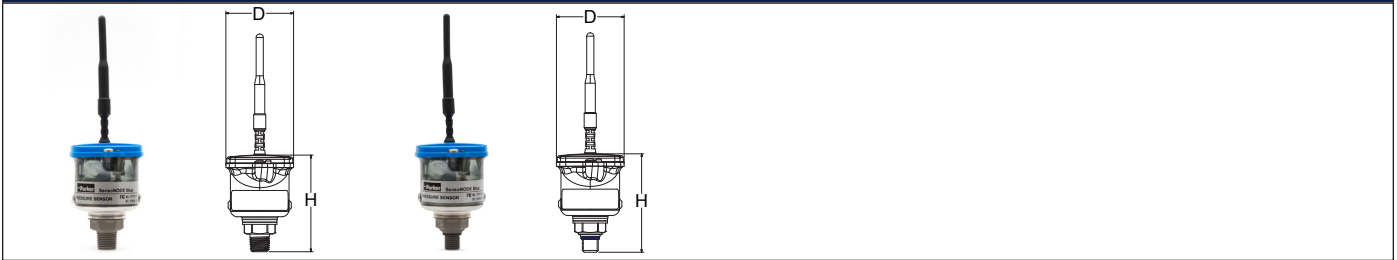

Part Number	Pressure Rating psi [bar]	Port	D	H
SNPT2-10-B-4MP	0-150 [10]	1/4" Male NPTF	ø1.88" [48mm]	2.66" [68mm]
SNPT2-100-B-4MO	0-1500 [100]	-4 SAE	ø1.88" [48mm]	2.72" [69mm]
SNPT2-250-B-4MO	0-3625 [250]	-4 SAE	ø1.88" [48mm]	2.72" [69mm]
SNPT2-400-B-4MO	0-5800 [400]	-4 SAE	ø1.88" [48mm]	2.72" [69mm]
SNPT2-600-B-4MO	0-8700 [600]	-4 SAE	ø1.88" [48mm]	2.72" [69mm]

Quick Couplers

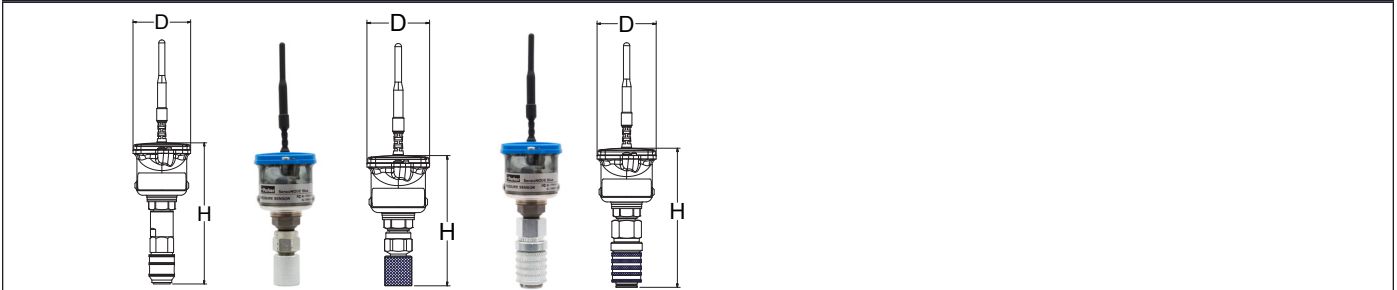

Part Number	Pressure Rating psi [bar]	Port	D	H
SNPT2-10-B-4MP-SPE	0-150 [10]	Spectrum	ø1.88" [48mm]	4.60" [117mm]
SNPT2-100-B-4MO-EMA	0-1500 [100]	EMA	ø1.88" [48mm]	4.00" [101mm]
SNPT2-250-B-4MP-EMA	0-3625 [250]	EMA	ø1.88" [48mm]	4.00" [101mm]
SNPT2-400-B-4MO-EMA	0-5800 [400]	EMA	ø1.88" [48mm]	4.00" [101mm]
SNPT2-600-B-4MO-EMA	0-8700 [600]	EMA	ø1.88" [48mm]	4.00" [101mm]
SNPT2-100-B-4MO-PD	0-1500 [100]	PD	ø1.88" [48mm]	4.40" [112mm]
SNPT2-250-B-4MO-PD	0-3625 [250]	PD	ø1.88" [48mm]	4.40" [112mm]
SNPT2-400-B-4MO-PD	0-5800 [400]	PD	ø1.88" [48mm]	4.40" [112mm]

How to Order:

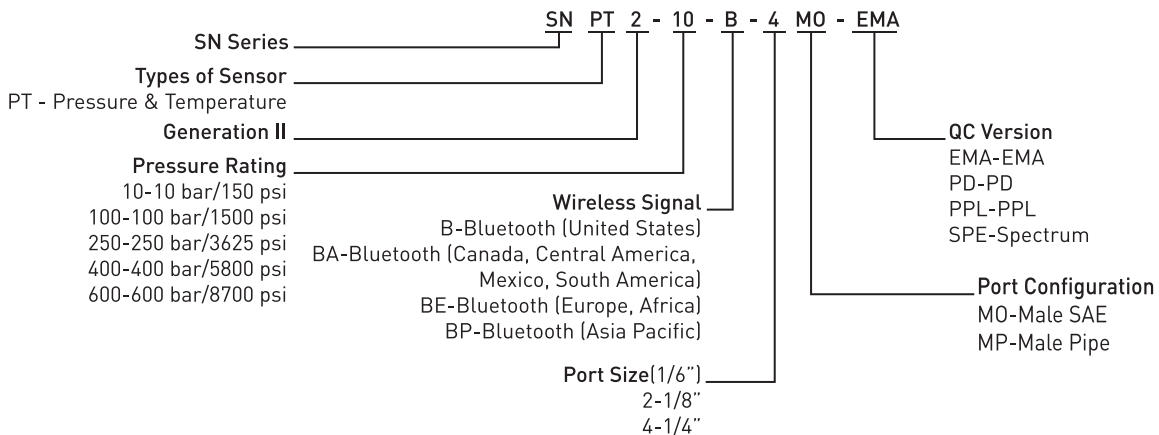





Features:

- Available in a unique clamp design for quick attachment to pipe or hard tubing
- User definable measurement units (F°/C°) for convenient and familiar data readings
- Ports: NPTF and SAE to make plumbing and connecting easier and faster
- Corrosion resistant materials for challenging environments
- User selectable scan and transmit rates (mode dependent). Currently 1,2,5, and 10 seconds. Refer to SCOUT Mobile for the up to date capabilities and modalities.

Sensor Technical Data

			
Body Seals	Fluorocarbon	Fluorocarbon	Nitrile
Housing Material	Polycarbonate	Polycarbonate	Nylon
Port	1/4" Male NPTF	-4 SAE	Clamp
Wetted Parts Material	17-4 Stainless	17-4 Stainless	Stainless
Working Pressure	0-10k psi [0-700 bar]	0-10k psi [0-700 bar]	N/A
Max. Overload Pressure	3x	3x	N/A
Burst Pressure	4x	4x	N/A
Accuracy (at 77°F/ 25°C)	±2.5%	±2.5%	±5.0%
Resolution (from 14°F to 120°F)[-10°C to 44.8°F]	1°F [.56°C]	1°F [.56°C]	2°F [1.12°C]
Scan and Transmit Rate	User Selectable	User Selectable	User Selectable
Ambient Temperature (battery limited)	-4°F to 167°F [-20°C to 75°C]	-4°F to 167°F [-20°C to 75°C]	-4°F to 167°F [-20°C to 75°C]
Fluid Temperature Range	-40°F to 230°F [-40°C to 110°C]	-40°F to 230°F [-40°C to 110°C]	-40°F to 257°F [-40°C to 125°C]
Full Range Life Cycles	> 1 million	> 1 million	N/A
Certifications	FCC, IC, CE*	FCC, IC, CE*	FCC, IC, CE
Battery (Panasonic is recommended brand)	CR123A	CR123A	CR2450
IP Rating	IP65	IP65	IP65

*CE approval in process, estimated approval Jan 1, 2016.



Temperature Sensors – Ported

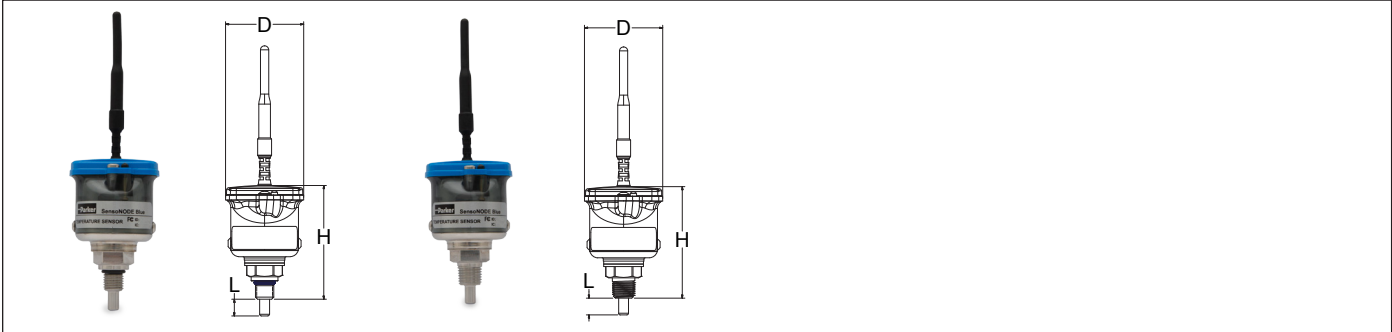

Part Number	Fluid Temperature Range	Port	D	H	L
SNT2-700-B-4MO	-40°F to 230°F [-40°C to 110°C]	-4 SAE	ø1.88" [48mm]	2.72" [69mm]	0.40" [10.16mm]
SNT2-700-B-4MP	-40°F to 230°F [-40°C to 110°C]	1/4" Male NPTF	ø1.88" [48mm]	2.66" [68mm]	0.40" [10.16mm]

Temperature Sensors – Clamp

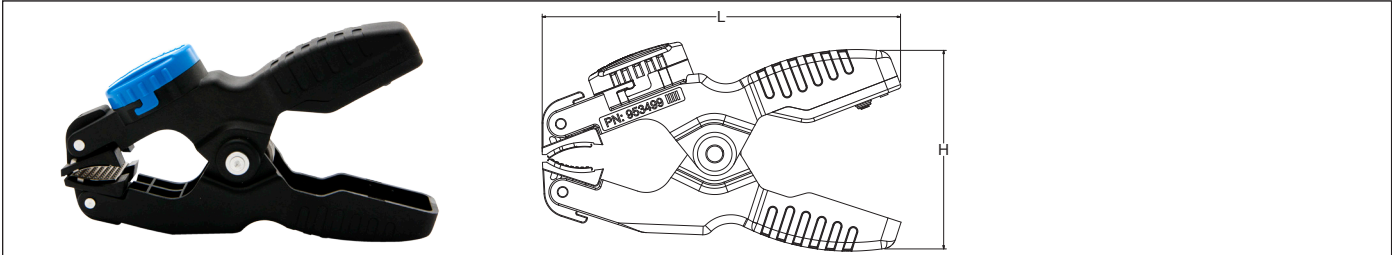

Part Number	Fluid Temperature Range	L	H	Optimal Clamping
SNT-0-B-CL-KB	-40°F to 257°F [-40°C to 125°C]	5.24" [133.1mm]	3.06" [77.7mm]	ø.25" to ø1.5" [ø6.4mm-ø38.1mm]

How to Order:

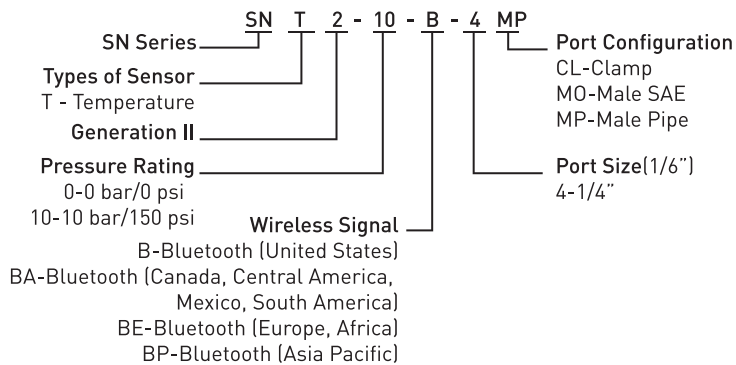



Features:

- 0-100% relative humidity
- Ideal for ambient condition and inert compressed gas monitoring applications
- Ports: NPTF to make plumbing and connecting easier and faster
- Corrosion resistant materials for challenging environments
- Should be mounted vertically.
- Sensor also provides temperature values.
- User selectable scan and transmit rates (mode dependent). Currently 1,2,5, and 10 seconds. Refer to the SCOUT Mobile for the up to date capabilities and modalities.

Sensor Technical Data

	
Body Seals	Fluorocarbon & Nitrile
Housing Material	Polycarbonate
Port	1/4" Male NPTF
Wetted Parts Material	Brass
Working Pressure	0-150 psi [10 bar]
Max. Overload Pressure	150 psi Max [10 bar]
Burst Pressure	4x
Accuracy (77°F/25°C, 20% RH to 80% RH, at ambient pressure)	±5% RH Max
Resolution (at 77°F/25°C)	0.1% RH
Scan and Transmit Rate	User Selectable
Response Time (from 33% to 75% RH)	10 secs
Ambient Temperature (battery limited)	-4°F to 167°F [-20°C to 75°C]
Operating Temperature (battery limited)	-4°F to 167°F [-20°C to 75°C]
Temperature Accuracy (from 14°F to 185°F [-10°C to 85°C])	±1.0°F [±0.5°C]
Full Range Life Cycles	> 1 million
Certifications	FCC, IC, CE*
Battery (Panasonic is recommended brand)	CR123A
IP Rating	IP65

*CE approval in process, estimated approval Jan 1, 2016.



Humidity Sensors

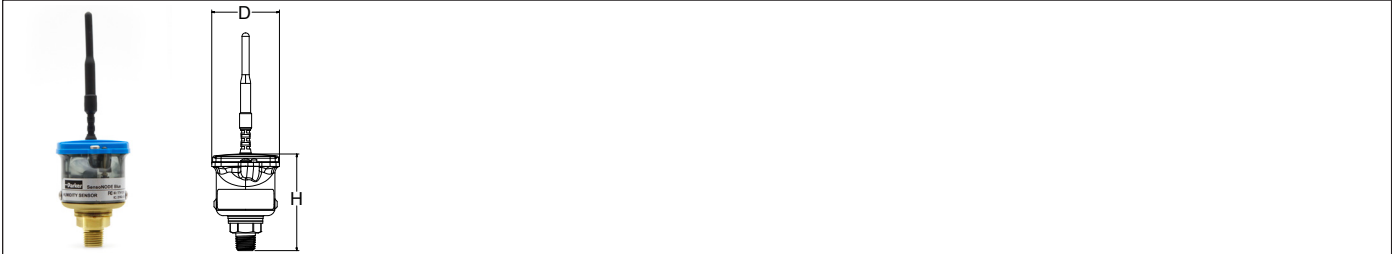

Part Number	RH Range	Port	D	H
SNHT2-10-B-4MP	0-100%	1/4" Male NPTF	ø1.88" [48mm]	2.66" [68mm]

How to Order:

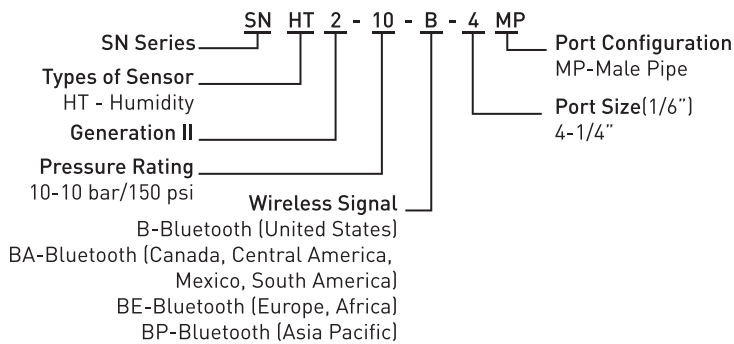

SensoNODE™ Accessory Case



SCC-260

SensoNODE™ Accessory Case

Product Number	L	W	D	Case	Temperature	Humidity	Pressure	Battery
SCC-260*	TBD	TBD	TBD	SCC-260	-	-	-	-

*Sensor products not included.

EMA3 Series – Test Port Couplings

Male Pipe Thread



Part Number	Port Thread Size	Wrench Flats	Interface Thread Size	Overall Length	Weight
EMA3/1/8NPT	1/8-27NPT	17	M16X2.0	1.81" [46mm]	0.15lb [.07kg]
EMA3/1/4NPT	1/4-18NPT	17	M16X2.0	1.98" [50.3mm]	0.16lb [.07kg]

SAE Straight Thread



Part Number	Port Thread Size	Wrench Flats	Interface Thread Size	Overall Length	Weight
EMA3/7/16-20UNF-2A*	7/16-20UNF	17	M16X2.0	1.88" [47.8mm]	0.15lb [.07kg]
EMA3/9/16-18UNF-2A*	9/16-18UNF	19	M16X2.0	1.88" [47.8mm]	0.17lb [.08kg]

*O-Ring seal on port

EMA Gauge Adapter



Part Number	Port Thread Size	Wrench Flats	Interface Thread Size	Overall Length	Weight
MAVMD1/4NPT-MA3	1/4-18NPT	19mm	M16X2.0	2.22" [56.4mm]	0.18lb [.08kg]
SCA-7/16-EMA-3	7/6-20	19mm	M16X2.0	1.60" [40.64mm]	0.15lb [.45kg]

Note: Consult factory or Catalog #3800 for additional accessories and port options.

PPL Series - Nipples - Valved



Push-Button

Part Number	Body Size	Port End	L	W	H
PPL-252-4MP	1/4	1/4 NPT	1.50" [38.1mm]	0.62lb [.28kg]	0.62" [15.8mm]
PPL-252-6MP	1/4	3/8 NPT	1.65" [41.9mm]	0.75lb [.34kg]	0.75" [19.0mm]



Hose Barb

Part Number	Body Size	Tube I.D.	L	W	H
PPL-252-4HB	1/4	1/4	1.80" [45.7mm]	0.70lb [.32kg]	0.70" [17.8mm]
PPL-252-5HB	1/4	5/16	1.85" [47.0mm]	0.70lb [.32kg]	0.70" [17.8mm]
PPL-252-6HB	1/4	3/8	1.67" [42.4mm]	0.70lb [.32kg]	0.70" [17.8mm]



Bulkhead Hose Barb with Nut

Part Number	Body Size	Tube I.D.	L	W	H
PPL-252-H4HB	1/4	1/4	1.87" [47.5mm]	0.74lb [.34kg]	0.74" [18.8mm]
PPL-252-H6HB	1/4	3/8	1.84" [46.7mm]	0.74lb [.34kg]	0.74" [18.8mm]

PPL Series - Coupler - Non-Valved



Male Thread

Part Number	Body Size	Port End	L	W	H
PPL-253-4MP	1/4	1/4 NPT	1.15" [29.2mm]	0.75lb [.34kg]	0.93" [23.6mm]

Spectrum Series (Sleeve Operated) - Nipples - Valved



Female Pipe

Part Number	Body Size	Thread Size	Overall Length	Hex Size	Largest Diameter
S2-ANV-04-FP	1/8	1/4-18 NPT	1.80" [45.7mm]	0.67" [17mm]	0.76" [19.3mm]



Male Pipe

Part Number	Body Size	Thread Size	Overall Length	Hex Size	Largest Diameter
S2-ANV-03-MP	1/8	1/4-18 NPT	1.80" [45.7mm]	0.67" [17mm]	0.76" [19.3mm]



Hose Barb

Part Number	Body Size	Hose I.D.	Overall Length	Hex Size	Largest Diameter
S2-ANV-03-HB	1/8	3/16	1.80" [45.7mm]	0.67" [17mm]	0.76" [19.3mm]
S2-ANV-04-HB	1/8	1/4	1.80" [45.7mm]	0.67" [17mm]	0.76" [19.3mm]



Bulkhead Hose Barb

Part Number	Body Size	Thread Size	Overall Length	Hex Size	Largest Diameter	Bulkhead Hex	Bulkhead Hole Diameter
S2-ANV-03-BHB	1/8	3/16	2.35" [59.7mm]	0.67" [17mm]	0.76" [19.3mm]	0.55" [14mm]	0.44" [11.18mm]

Spectrum Series (Sleeve Operated) - Coupler



Female Pipe

Part Number	Body Size	Thread Size	Overall Length	Hex Size	Largest Diameter
S2-ACV-02-FP	1/8	1/4-18NPT	2.16" [54.9mm]	0.67" [17mm]	0.82" [20.9mm]

SCOUT Mobile Software

With an easy-to-use interface and compatibility with your mobile device, SCOUT Mobile puts vital information and analytics in the palm of your hand. Through wireless connection, SCOUT Mobile software compiles data collected by SensoNODE Blue sensors and presents it in a way that makes sense to your operation, giving you the analytics you need to optimize your assets' performance.

SCOUT Mobile also alerts users to unexpected condition changes that may damage components and equipment. As levels rise above or fall below user-defined thresholds, users are alerted to these events, giving them an opportunity to address potential issues that could harm the system overtime.

With real-time and historic trends, users receive the vital analytics they need to address these changes before they cause problems, helping to reduce unplanned downtime and increase productivity.

**Capabilities:**

- Mobile application designed for iOS (Android coming January 2016)
- Connect and display SensoNODE sensors

Features:

- Auto recognition enables users to quickly discover and connect up to five sensors concurrently
- Robust data presentation delivered through digital and analog interface
- View real-time information that includes current values and minimum/maximum indicators in addition to historical sensor information
- Improve awareness with user definable alert improving action management with alert acknowledgements and triage
- Easy to use user interface with familiar design and pinch and zoom functionality

* To download SCOUT Mobile from App Store on an iPad, select the iPhone only device filter.



Sensor **Data Views** // Realtime

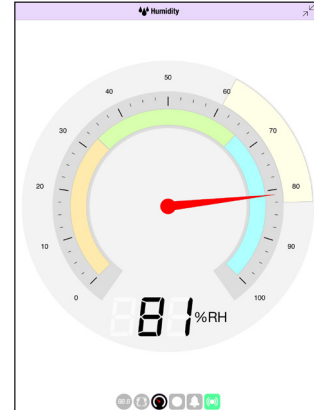

Sensor **Data Views** // Trend

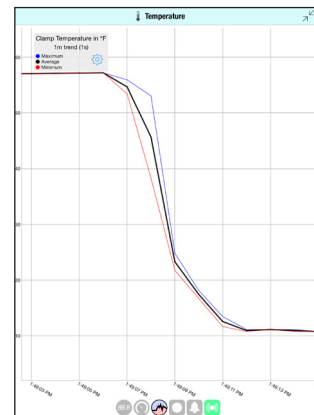

Size:

- 22.0 MB

Compatibility:

- Requires iOS 8 or later

Languages:

- English

Supported Devices:

- iPhone 4S, 5, 5S, 5C, 6, 6+, 6s, 6s+
- iPod Touch (5th Generation)
- iPad 3, 4
- iPad Air
- iPad Mini

Sensor **Data Views** // Historic



Parker Fluid Connectors Group

Your complete source for quality tube fittings, hose & hose fittings, brass & composite fittings, quick-disconnect couplings, valves, and assembly tools, locally available from a worldwide network of authorized distributors.

Fittings:

Available in inch and metric sizes covering SAE, BSP, DIN, GAZ, JIS, and ISO thread configurations, manufactured from steel, stainless steel, brass, aluminum, nylon, and thermoplastic.

Hose, Tubing, and Bundles:

Available in a wide variety of sizes and materials including rubber, wire-reinforced, thermoplastic, hybrid and custom compounds.

Worldwide Availability:

Parker operates Fluid Connectors manufacturing locations and sales offices throughout North America, South America, Europe, and Asia-Pacific.

For more information on **SensoNODE** and **SCOUT** products:

Visit: www.parker.com/conditionmonitoring

Call: (763) 544-7781

For more information on **SensoControl Wired Diagnostic** and **Control** products:

Visit: www.parker.com/sensocontrol

Call: (763) 544-7781

Sales of **SensoNODE** sensors and **SCOUT** software in U.S. only

