

## DIN RAIL POWER SUPPLIES

# SELECTION GUIDE

**PULS**  
DIMENSION

DC 24V 10A

24 20V

Parallel Use  
Single Use

DC ok

**PULS**  
DIMENSION

CT18  
Power Supply

**PULS**  
DIMENSION

CT18  
Power Supply

**PULS**  
PIANO

PIC 240 2410  
Power Supply

**PULS**  
DIMENSION

**PULS**  
DIMENSION

**PULS**  
DIMENSION

**PULS**  
DIMENSION

**PULS**  
PIANO

**PULS**  
PIANO

**PULS**  
DIMENSION



DC 24V 10A

DC ok

24-20V

DC ok  
13  
14

**PULS**  
PIANO

PIC 240 2410  
Power Supply

AC 100 240V

# Content

About PULS	4-5
Portfolio	6-7
New Products	8-9
Overview	10-17
Power Supplies	18-31
1-Phase power supplies	18-27
3-Phase power supplies	28-29
DC/DC-converters	30-31
Special Markets	32-33
Railway	32
Medical, Marine	33
Application Analysis Tool	34
Power-over-Ethernet	35
Redundancy	36-39
Power supplies with integrated decoupling function	36-37
Redundancy modules	38-39
Protection Modules	40-41
DC-UPS	42-46
DC-UPS with batteries	42-44
DC-UPS, buffer modules	45-46
Mounting Brackets	46
PULS product details for CAE-software	47
Customised Solutions	48-49
Standards and Approvals	50-57
Contact	58-59
Footnotes	60



Bernhard Erdl  
CEO, Chief Developer  
and Founder



Headquarters  
Munich



Environmentally friendly production  
in Czech Republic and China

# PULS – The Technology Leader

Efficient. Innovative. Different.

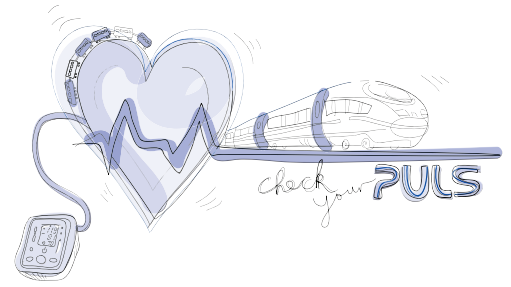

When I founded PULS over 35 years ago, we were a handful of developers with a common goal: We wanted to revolutionise the power supply technology.

Today PULS is a global market and technology leader in the field of DIN rail power supplies.

This was made possible by our focus and a great team that naturally strives for the next stage of innovation for every new PULS product. This ambition can continuously be experienced by our customers in power supplies with the maximum efficiency levels, longest lifetime, smallest dimensions and absolute reliability.

The power supplies and relevant add-ons are developed at our inspiring headquarters in the heart of Munich as well as the innovation laboratory in Vienna. The efficient, family-like and value-oriented work environment, as well as the central location contribute to making PULS so attractive for the best engineers, specialists and up-and-coming talents.

Production is carried out in our own smart and environmentally friendly factories in the Czech Republic and China. The entire value chain runs entirely under our surveillance, as this level of control is very important to us. In customer audits, our factories are repeatedly praised for their efficiency, streamlined structure and environmentally friendly objectives.

We have established a broad range of standard power supplies available from stock at any time, offering the right solution for every application. We can individually modify standard devices or offer customised system solutions if required.

Our sales department offers expert advice at all times, providing ongoing technical support from our application specialists.

I am proud of what we have achieved for our customers over the past few decades. The future promises many more exciting innovations in the field of DIN rail power supplies. Be a part of it!

Bernhard Erdl  
CEO, Chief Developer and Founder

[www.pulspower.com](http://www.pulspower.com)

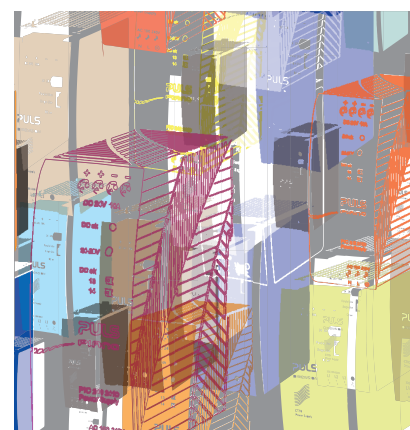



## Dependability

- High MTBF values and long lifetime
- Outstanding efficiency
- Cool-design for low temperatures
- Production-friendly setup
- Long product availability

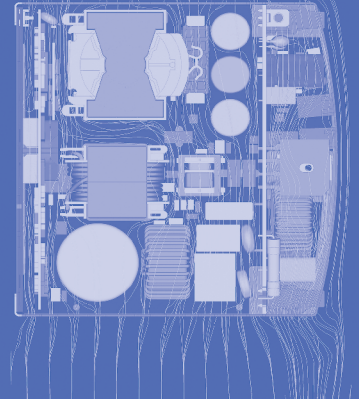

## Products

- At the forefront of technology
- Unique efficiency approx. 95%
- Small and lightweight
- High peak output current
- Easy to use
- Wide product portfolio

## Focus

- All resources focused on DIN rail power supplies
- High-performance organisational structure
- Decades of competence

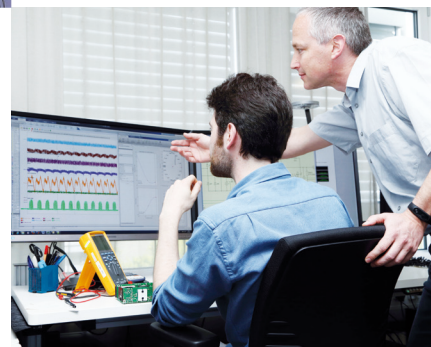

# The perfect power for every



## DIMENSION

Highest performance with numerous variants, features and approvals.  
Series: C, PISA, Q, U, X, Z



## PIANO

Focus on basic functionalities without compromising on quality and reliability.  
Series: PIC, PIM, PIRD



## MiniLine

Ultra compact design for low-power applications.  
Serie: ML

# supply application

## DIMENSION MiniLine PIANO

	<b>DIMENSION</b>	<b>PIANO</b>	<b>MiniLine</b>
	Full featured	Cost oriented	Low-power
<b>INPUT / OUTPUT</b>			
Input voltage	1-phase, 3-phase, DC	1-phase	1-phase, 3-phase, DC
Output voltage (DC)	12 / 24 / 30 / 36 / 48V	24V / 48V	5 / 10 / 12 / 15 / 24 / 30 / 48V
Output power	80-960W	36-480W	15-100W
<b>FEATURES</b>			
Power reserves	✓✓	—	—
Efficiency, 24V versions	96.0%	95.7%	91.0%
Housing material	Aluminum	Polycarbonate (PC)	PC-ABS-Blend
Parallel operation	✓✓	✓	✓✓
DC-OK relay contact versions	✓✓	✓✓	✓✓
Long lifetime	✓✓	✓✓	✓✓
Fuse breaking capability	✓✓	✓	—
Resists high power transient voltages	✓✓	✓✓	✓
<b>ENVIRONMENT</b>			
Operating temperature range	-25°C ... +70°C*	-10°C ... +70°C*	-10°C ... +70°C*
Conformally coated versions	✓✓	—	✓
Hazardous environment	✓	—	✓
High mechanical stress (shock & vibration)	✓✓	✓✓	✓✓

\* Special versions with broader temperature range available.

# New Products

## PIANO

PIM series  
36-90W, 1-phase



### Easy Flexible. Mini.

The most recent as well as the smallest representative products with regards to the PIANO-family are the 24V DIN rail power supplies and supplementary devices such as PIM36 (36W), PIM60 (60W) und PIM90 (90W). As a result, PIANO users are now offered a complete and cost-oriented product family being fully compatible in a power range of 36-480W.



#### PIM36

24V / 1.5A  
22.5x90x91mm (WxHxD)  
138g  
push-in terminals

available soon  
more information p. 20



#### PIM60

12V / 5A and 24V / 2.5A  
36x90x91mm (WxHxD)  
220g  
push-in or screw terminals

more information p. 21



#### PIM90

24V / 3.8A  
36x90x91mm (WxHxD)  
270g  
push-in or screw terminals  
also available as NEC Class 2 version

more information p. 21



# DIMENSION

IO-Link  
960W, 3-phase



## Efficient. Easy. Connected.

As a member of the well-known QT series, this version offers a digital communication interface. It is based on the widespread IO-Link standard, which allows the adaptation to various field bus protocols.

With a comprehensive and well-chosen set of operating data, the QT40.241-B2 enables preventive maintenance measures. Due to near-time communication (events), failures can be fixed before they occur. Customers will benefit from increased process uptimes and long-term cost savings.

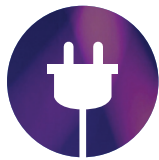

**Save time**  
Plug-and-Play installation



**Save costs**  
preventative maintenance



**Improve customer service**  
speed up fault analysis

## Technical Data

Output	
Output voltage range	24 - 28V (via potentiometer) 15 - 28V (remote via IO-link)
Output current nominal	40A
Output current temporary	60A (5s)
Output transient current	100A (10ms) $U_{out} > 20V$
Overload behaviour	constant current mode

General	
Efficiency	95.3%
Lifetime expectancy (40°C)	69kh
MTBF SN29500, IEC 61709	685kh
Hold-up time, typ.	25ms
Operating temperature	-25°C to 70°C
Dimensions WxHxD	110x124x127mm
Weight	1500g
Warranty	3 years
Approvals (planned)	CE, cULus 61010-2 listed
Article number	QT40.241-B2

Input	
AC input voltage nominal	380 - 480V
AC input voltage range	323 - 576V
Power factor	0.92
AC inrush current, typ.	< 4.5A

Data communication	
Protocol (standard)	IO-Link v1.1 (IEC 61131-9)
Power supply	24V over ComLine
Configuration	upload IODD, plug-and-play
Transmission speed	< 230.4 kBaud
Transmission distance	up to 20m
Transmission medium	3 wires
Memory	8 Kbit EEPROM
Connector	PG male connector
Thread	M12
No. of pins	4, A code

All parameters are specified at nominal values, 3x400Vac, 50Hz, 25°C ambient temperature and 5 minutes run-in time unless otherwise noted.

# 100-240V AC/DC-Converters

Output	Article number	Page	Power	Input AC	Input DC	Special Features	
5V	3A	ML15.051	18	15W	AC 100-240V	DC 110-300V	
	5A	ML30.101	18	25W		DC 110-300V	
12V	1.3A	ML15.121	18	15W	AC 100-240V	DC 110-300V	
	2.5A	ML30.102	18	30W		DC 110-300V	
	4.2A	ML50.102	18	50W		DC 110-300V	
	4.5A	ML60.121	18	54W		DC 110-300V	
		ML60.122	19			DC 110-300V	-40°C operation
	5A	PIM60.121	19	60W	AC 100-240V	--	push-in clamps
		PIM60.125	19			--	
	7.5A	ML100.102	19	90W	AC 100-120 / 220-240V	DC 290V	
	10A	CP5.121	19	120W	AC 100-240V	DC 110-150V	
	15A	QS10.121	19	180W		DC 110-150V	
	16A	CP10.121	19	192W		DC 110-150V	shut-down input
		CP10.122	19			DC 110-300V	
	30A	CPS20.121	19	405W		--	
±12V	2.5A	ML30.106	19	36W	AC 100-240V	DC 110-300V	dual-output voltage
24V	0.63A	ML15.241	20	15W	AC 100-240V	DC 110-300V	
		ML30.100	20	30W		DC 110-300V	
	1.3A	ML30.241	20			DC 110-300V	
		PIM36.241	20	36W	AC 100-240V	--	push-in clamps
	2.1A	ML50.100	20	50W	AC 100-240V	DC 110-290V	
		ML50.101	20			DC 110-300V	
		ML50.111	20			DC 110-300V	with plug connector
	2.5A	ML60.241	21	60W	AC 100-240V	DC 110-300V	
		ML60.242	21			DC 110-300V	-40°C operation
	3A	PIM60.241	21			--	push-in clamps
		PIM60.245	21			--	
	3A	ML70.100	21	72W	AC 100-120 / 220-240V	DC 290V	
	3.3A	CS3.241	21	80W	AC 100-240V	DC 110-300V	
	3.4A	QS3.241	21			DC 110-300V	
	3.75A	PIM90.241	21	90W		--	push-in clamps
		PIM90.245	21			--	
		PIM90.245-L1	21			--	NEC Class 2
	3.8A	QS5.DNET	21	91W		DC 110-300V	DeviceNet approved
	3.9A	ML95.100	22	95W	AC 100-120 / 220-240V	DC 290V	NEC Class 2
	4.2A	ML100.100	22	100W		DC 290V	
5A	CP5.241	22	120W	AC 100-240V	DC 110-150V		
	CP5.241-S1	22			DC 110-150V	spring clamps	
	CP5.241-S2	22			DC 110-150V	push-in clamps	
	CS5.241	22		AC 100-120 / 200-240V	--		
	CS5.241-S1	22			--	spring clamps	
	CP5.242	22			DC 110-300V		
	CS5.243	22		AC 100-120V	--		
	CS5.244	22		AC 200-240V	--		

<b>DIMENSION</b>	C, PISA, Q, U, X, Z
<b>PIANO</b>	PIC, PIM, PIRD
<b>MiniLine</b>	ML

Output	Article number	Page	Power	Input AC	Input DC	Special Features			
<b>24V</b>	5A	PIC120.241C	22	120W	AC 200-240V	--			
		PIC120.242C	22		--				
		PIC120.241D	23		AC 100-120/ 200-240V	--			
		QS5.241	23		DC 110-300V				
	8A	QS10.DNET	23	192W	DC 110-150V	DeviceNet approved			
	10A	CP10.241	23	240W	AC 100-240V	DC 110-150V			
		CP10.241-S1	23		DC 110-150V	spring clamps			
		CP10.241-S2	23		DC 110-150V	push-in clamps			
		CP10.242	23		DC 110-300V	extended DC input			
		PIC240.241C	24		AC 200-240V	--			
		PIC240.241D	24		AC 100-240V	--			
		CS10.241	23		AC 100-120 / 200-240V	--			
		CS10.241-S1	23		--	spring clamps			
		CS10.242	23		--				
		CS10.243	23		AC 100-120V	--			
		CS10.244	23		AC 200-240V	--			
		QS10.241	24		AC 100-240V	DC 110-150V			
		QS10.241-D1	24		DC 110-300V				
		20A	CP20.241		24	480W	AC 100-240V	DC 110-150V	
			CP20.241-S1		24		DC 110-150V	spring clamps	
CP20.241-S2			24		DC 110-150V		push-in clamps		
CP20.241-V1	24		DC 110-150V	remote shut-down					
PIC480.241C	24		AC 200-240V	--					
PIC480.241D	25		AC 100-240V	--					
CPS20.241	25		--						
QS20.244	25		AC 200-240V	--					
QS20.241	25		AC 100-240V	DC 110-150V					
40A	QS40.241		25	960W	AC 100-240V		--		
	QS40.244	25	AC 200-240V		--				
<b>30V</b>	8A	QS10.301	25	240W	AC 100-240V	DC 110-150V			
<b>36V</b>	6.7A	CP10.361	26	480W	AC 100-240V	DC 110-150V			
	13.3A	CPS20.361	25		--				
		QS20.361	25		DC 110-150V				
26.7A	QS40.361	26	960W	--					
<b>48V</b>	1.1A	ML50.105	26	50W	AC 100-240V	DC 110-300V			
	2.1A	ML100.105	26	100W	AC 100-120 / 220-240V	DC 290V			
	2.5A	CP5.481	26	120W	AC 100-240V	--			
	5A	CS10.481	26	240W	AC 100-120 / 200-240V	--			
		QS10.481	27		AC 100-240V	DC 110-150V			
		QS10.481-D1	27		DC 110-300V	extended DC input			
	5.4A	CP10.481	27	260W	DC 110-150V				
	10A	CP20.481	27	480W	DC 110-150V				
		CPS20.481	27		--				
		PIC480.481D	27		--				
		QS20.481	27		DC 110-150V				
	20A	QS40.481	27	960W	DC 110-150V				
QS40.484		27	AC 200-240V						

# 380-480V AC/DC-Converters

Output		Article number	Page	Power	Input AC	Special Features
12V	8A	CT5.121	28	96W	2AC 380-480V	
24V	3.75A	ML90.200	28	90W	2AC 380-480V	NEC Class 2
	4.2A	ML100.200	28	100W		
	5A	CT5.241	28	120W		
	10A	CT10.241	28	240W	3AC 380-480V	
	20A	QT20.241	28	480W		
	40A	QT40.241	28	960W		
		QT40.242	28			enhanced lifetime
		XT40.241	29		3AC 400V	semi-regulated
XT40.242		29		3AC 480V	semi-regulated	
36V	13.3A	QT20.361	29	480W	3AC 380-480V	
	26.6A	XT40.361	29	960W	3AC 400V	semi-regulated
		XT40.362	29		3AC 480V	semi-regulated
	26.7A	QT40.361	29		3AC 380-480V	
48V	5A	CT10.481	29	240W	3AC 380-480V	
	10A	QT20.481	29	480W		
	20A	QT40.481	29	960W		
		XT40.481	29		3AC 400V	semi-regulated
		XT40.482	29			semi-regulated
72V	13.3A	XT40.721	29		3AC 400V	semi-regulated
		XT40.722	29		3AC 480V	semi-regulated

# DC/DC-Converters

Output		Article number	Page	Power	Input DC	Special Features
12V	8A	CD5.121	30	96W	DC 24V	
24V	3.8A	CD5.241-L1	30	92W	DC 24V	NEC Class 2
	4A	CD5.243	30	96W	DC 12V	
	5A	CD5.241-S1	30	120W	DC 24V	
		CD5.242	31		DC 48V	
		CD5.241	30		DC 24V	
	10A	CD10.241	31	240W	DC 24V	
		CD10.242	new 31		DC 48V	
20A	QTD20.241	31	480W	DC 600V	for intermediate DC-bus	
48V	5A	CD10.482	31	240W	DC 48V	

# Power Supply with IO-link

Output	Article number	Page	Power	Input	Special Features
24V	40A	QT40.241-B2	960W	3AC 380-480	digital communication interface

# Injektors and Power Supplies for PoE

Output	Article number	Page	Power	Eingang	Special Features
48-56V je Port	POE.8AT-AC1	35	8x30W	AC 100-240V	PoE power supply IEEE802.3AT
	POE.4AT-AC1	35	4x30W	AC 100-240V	PoE injector IEEE802.3AT
	POE.8AT-DC1	35	8x30W	DC 48-56V	PoE power supply IEEE802.3AT
	POE.4AT-DC1	35	4x30W	DC 48-56V	PoE injector IEEE802.3AT



<b>DIMENSION</b>	C, PISA, Q, U, X, Z
<b>PIANO</b>	PIC, PIM, PIRD
<b>MiniLine</b>	ML

# Conformally Coated Power Supplies

Output		Article number	Page	Power	Input AC	Input DC	Special Features
24V	2.1A	ML50.109	20	50W	AC 100-240V	DC 110-290V	
	4.2A	ML100.109	22	100W	AC 100-120 / 220-240V	DC 290V	
	5A	CP5.241-C1	22	120W	AC 100-240V	DC 110-150V	
		CS5.241-C1	22			--	
		QS5.241-A1	23			DC 110-300V	ATEX
	10A	CP10.241-C1	23	240W	AC 100-240V	DC 110-150V	
		CP10.241-R2-C1	37			DC 110-150V	
		QS10.241-C1	23			DC 110-150V	
		QS10.241-A1	24			DC 110-150V	ATEX
		CT10.241-C1	28		3AC 380-480V	--	
	20A	CP20.241-C1	24	480W	AC 100-240V	DC 110-150V	
		CP20.241-R2-C1	37			DC 110-150V	
		CPS20.241-C1	24			--	
		QS20.241-A1	25			DC 110-150V	ATEX
		QS20.241-C1	25			DC 110-150V	
QT20.241-C1		28		3AC 380-480V	--		
48V	10A	PIC480.241C-C1	24		AC 200-240V	--	

## Mounting Brackets

Article number	Page	Description
ZM1 – ZM3.WALL, ZM1.UBC10	46	mounting bracket for a direct wall or panel mounting without a DIN rail
ZM10.WALL	46	mounting bracket for a direct wall or panel mounting without a DIN rail
ZM11.SIDE – ZM15.SIDE	46	brackets for sideways installation with or without a DIN rail



# Medical Applications

Output	Article number	Page	Power	Input AC	Input DC
24V 10A	CP10.241-M1	33	240W	AC 100-240V	DC 110-150V

# Railway Applications

Output	Article number	Page	Power	Input DC
24V	4.2A	QS5.241-60	100W	DC 110V
	8.3A	CP10.241-60	200W	DC 96-110V
		QS10.241-60		
24.5V 16.3A	CPS20.241-60	32	400W	DC 110V

# DeviceNet Power Supplies

Output	Article number	Seite	Power	Input AC	Special Features
24V	3.8A	QS5.DNET	91W	AC 100-240V	NEC Class 2
	8A	QS10.DNET	192W		NEC Class 1

<b>DIMENSION</b>	C, PISA, Q, U, X, Z
<b>PIANO</b>	PIC, PIM, PIRD
<b>MiniLine</b>	ML



# DIODE Redundancy Modules

Output	Article number	Page	Input	Version
DC 12-28V	20A PIRD20.241	38	DC 12-28V 2x10A	dual-input diode redundancy module
DC 12-48V	10A MLY10.241	38	DC 12-48V 2x5A	dual-input diode redundancy module
	MLY02.100	38	DC 12-48V 2x5A	dual-input diode redundancy module
	20A YR2.DIODE	38	DC 12-48V 2x10A	dual-input diode redundancy module
DC 24-48V	20A YRM2.DIODE	38	DC 24-48V 2x10A	dual-input diode redundancy module

# MOSFET Redundancy Modules

Output	Article number	Page	Input	Version	
DC 12-28V	20A YR20.242	39	DC 12-28V 2x20A	dual-input MOSFET redundancy module	
	40A	YR40.242	39	DC 12-28V 2x20A	dual-input MOSFET redundancy module
		YR40.241	39	DC 24-28V 2x20A	dual-input MOSFET redundancy module
		YR40.245	39	1x40A	single-input MOSFET redundancy module
		YR80.241	39	DC 24-28V 2x40A	dual-input MOSFET redundancy module
	YR80.242	39	DC 12-28V 2x40A	dual-input MOSFET redundancy module	
DC 24-28V	20A YR20.246	39	DC 24-28V 2x10A	dual-input MOSFET redundancy module	
DC 24-56V	40A YR40.482	39	DC 24-56V 2x20A	dual-input MOSFET redundancy module	

# Power Supplies with Integrated Decoupling Function

Output	Article number	Page	Power	Input AC	Input DC	Special Features
DC 24V	10A	CP10.241-R1	240W	AC 100-240V	DC 110-150V	spring clamps
		CP10.241-R2			DC 110-150V	hot-swap connectors
		CP10.241-R2-C1			DC 110-150V	
		CP10.242-R2			DC 110V-300V	
	20A	CP20.241-R1	480W	DC 110V-150V		
		CP20.241-R2		DC 110-150V	hot-swap connectors	
		CP20.242-R2		DC 110V-300V	hot-swap connectors	
		CP20.241-R2-C1		DC 110V-150V	hot-swap connectors	

<b>DIMENSION</b>	C, PISA, Q, U, X, Z
<b>PIANO</b>	PIC, PIM, PIRD
<b>MiniLine</b>	ML



# DC-UPS with Batteries

Output	Article number	*	Page	Battery	Version
DC 24V	10A	UB10.241	42	external, 12V, 3.9-40Ah	battery DC-UPS
		UB10.242	42	external, 12V, 17-130Ah	battery DC-UPS
		UB10.245	42	external, 12V, 3.9-40Ah	with additional 12V output
		UBC10.241	42	built-in 12V, 5Ah	DC-UPS with integrated battery
		UBC10.241-N1	42	built-in 12V, 5Ah	battery not assembled
20A	UB20.241	42	external, 12V, 3.9-150Ah	DC-UPS	

# DC-UPS with Capacitor Storage

Output	Article number	*	Page	Capacitor Storage
DC 24V	15A	UC10.241	45	6kWs, typ. buffer time 9s at 15A
		UC10.242	45	12kWs, typ. buffer time 18s at 15A

# Buffer Modules with Capacitor Storage

Output	Article number	Page	Capacitor Storage	
DC 24V	20A	UF20.241	45	0.2kWs, typ. buffer time 310ms at 20A
	40A	UF40.241	45	0.32kWs, typ. buffer time 250ms at 40A
DC 48V	20A	UF20.481	45	0.2kWs, typ. buffer time 150ms at 20A

# Protection Modules

Article number	Page	Special Features
PISA11.401	40	4-channel protection module; outputs: 4x1A
PISA11.402	40	4-channel protection module; outputs: 4x2A
PISA11.403	40	4-channel protection module; outputs: 4x3A
PISA11.404	40	4-channel protection module; outputs: 4x4A
PISA11.406	40	4-channel protection module; outputs: 4x6A
PISA11.410	41	4-channel protection module; outputs: 4x10A
PISA11.203206	41	4-channel protection module; outputs: 2x3A and 2x6A
PISA11.206212	41	4-channel protection module; outputs: 2x6A and 2x12A
PISA11.CLASS2	41	4-channel protection module; outputs: 4x NEC Class 2 listed as „Limited Power Source“, < 100VA per channel

# 100-240V AC/DC-Converter

5V  
12V

15-28W  
15-405W

Output Voltage	5V		12V			
Output Current	3A	5A	1.3A	3.0A	4.2A	4.5A
Adjustment Range	5-5.5V	5-5.5V	12-15V	10-12V	12-15V	12-15V
Output Current	3.0A	5.0A	1.3-1.0A	3-2.5A	4.2-3.4A	4.5-3.6A
Output Power	15W	25W	15W	30W	50W	54W
Power Reserves	-	-	-	-	-	-
Ripple & Noise max. [mV <sub>pp</sub> ]	50mV	50mV	75mV	10mV	100mV	50mV
AC Input Voltage	AC 100-240V wide range	AC 100-240V wide range	AC 100-240V wide range	AC 100-240V wide range	AC 100-240V wide range	AC 100-240V wide range
DC Input Voltage	DC 110-300V	DC 110-300V	DC 110-300V	DC 110-300V	DC 110-300V	DC 110-300V
Power Factor, typ.	0.44	0.53	0.44	0.53	0.52	0.5
Input Inrush Current Limiter	NTC	NTC	NTC	NTC	NTC	NTC
Input Inrush Current <sup>k)</sup>	16A/31A	17A/35A	16A/31A	17A/35A	17A/35A	16A/32A
External Input Fuse Recommendation min.	B - 6A or C - 3A	B - 10A or C - 6A	B - 6A or C - 3A	B - 10A or C - 6A	B - 10A or C - 6A	B - 10A or C - 6A
Efficiency, typ.	77.2%	80.0%	82.5%	84.0%	90.0%	87.2%
Power Losses, typ.	4.5W	6.3W	3.2W	5.8W	6.0W	7.9W
MTBF (+40°C, SN 29500)	2686 kh	1963 kh	3811 kh	650 kh	600 kh	1690 kh
Min. Lifetime (+40°C)	93 kh	TBD	125 kh	TBD	TBD	56 kh
Operat. Temperature Range	-10°C to +70°C	-10°C to +70°C	-10°C to +70°C	-10°C to +70°C	-10°C to +70°C	-10°C to +70°C
Derating	0.4W/°C <sup>m)</sup>	0.5W/°C <sup>m)</sup>	0.4W/°C <sup>m)</sup>	0.8W/°C <sup>m)</sup>	1.3W/°C <sup>m)</sup>	1.4W/°C <sup>m)</sup>
Connection Terminals	screw	spring	screw	spring	spring	screw
Dimensions WxHxD	22.5x75x91mm	45x75x91mm	22.5x75x91mm	45x75x91mm	45x75x91mm	45x75x91mm
Weight	130g	240g	130g	250g	260g	250g
DC-OK Relay Contact	-	-	-	-	-	-
Special Features				very low output noise		
Order Info	stock item	stock item	stock item	stock item	stock item	stock item
Product Family	MiniLine	MiniLine	MiniLine	MiniLine	MiniLine	MiniLine
Article number	<b>ML15.051</b>	<b>ML30.101</b>	<b>ML15.121</b>	<b>ML30.102</b>	<b>ML50.102</b>	<b>ML60.121</b>

1) ML30.106: Both outputs can flexibly be loaded up to this current as long as the output power remains less than 36W. The current at the output with the lower load should be at least 5% of the output with the higher load.

footnotes a) - m) on page 60, or click here

# 1-Phase

## 100-240V AC/DC-Converter

5V, 12V 15-405W



**NEW**

12V							±12V
4.5A	5A	7.5A	10A	15A	16A	30A	2.5A
12-15V	12-15V	12-15V	12-15V	12-15V	12-15V	12-15V	±12-15V
4.5-3.6A	5.0-4.0A	7.5-6A	10-8A	15-13.5A	16-12.8A	30/27A	2.5A <sup>1)</sup>
54W	60W	90W	120W	180W	192W	360/405W	36W
-	-	-	20%	50%	20%	20%	-
50mV	50mV	50mV	50mV	50mV	50mV	100mV	50mV
AC 100-240V wide range	AC 100-240V wide range	AC 100-120V/220-240V auto-select	AC 100-240V wide range	AC 100-240V wide range	AC 100-240V wide range	AC 100-240V wide range	AC 100-240V wide range
DC 110-300V	-	DC 290V	DC 110-150V	DC 110-150V	DC 110-150V	-	DC 110-300V
0.44	0.49	0.55	TBD	0.92	0.96	0.95	0.53
active	NTC	NTC	NTC	active	active	active	NTC
6A/6A	14A/31A	22A/37A	4A/3A	4A/7A	6A/9A	9A/7A	17A/35A
B - 6A or C - 3A	B - 6A or C - 4A	B - 10A or C - 6A	B - 6A or C - 6A	B - 6A or C - 4A	B - 6A or C - 6A	B - 10A or C - 10A	B - 10A or C - 6A
87.6%	90.7%	88.5%	TBD	91.8%	94.3%	92.6%	86.0%
7.6W	6.2W	11.7W	TBD	16.1W	11.6W	28.8W	5.9W
1571 kh	TBD	500 kh	TBD	631 kh	690 kh	554 kh	600 kh
56 kh	89 kh	TBD	TBD	76 kh	97 kh	54 kh	TBD
-40°C to +70°C	-10°C to +70°C	-10°C to +70°C	-25°C to +70°C	-25°C to +70°C	-25°C to +70°C	-25°C to +70°C	-10°C to +70°C
1.4W/°C <sup>m)</sup>	1.5W/°C <sup>m)</sup>	2.5W/°C <sup>m)</sup>	3W/°C <sup>m)</sup>	5W/°C <sup>m)</sup>	4.8W/°C <sup>m)</sup>	0.75A/°C <sup>m)</sup>	1W/°C <sup>m)</sup>
screw	push-in	spring	screw	spring	screw	screw	spring
45x75x91mm	36x90x91mm	72.5x75x103mm	32x124x102	60x124x117mm	39x124x117	65x124x127mm	45x75x91mm
250g	225g	360g	440g	930g	600g	1000g	240g
-	-	-	yes	yes	yes	yes	-
-40°C operation					shut-down input		dual-output voltage
stock item	stock item	stock item	stock item	stock item	stock item	stock item	stock item
MiniLine	PIAD	MiniLine	DIMENSION	DIMENSION	DIMENSION	DIMENSION	MiniLine
ML60.122	PIM60.121 PIM60.125 <sup>o)</sup>	ML100.102	CP5.121	QS10.121	CP10.121 CP10.122 <sup>d)</sup>	CPS20.121	ML30.106

# 100-240V AC/DC-Converter

## 24V

## 15-91.2W

NEW

Output Voltage	24V					
Output Current	0.63A	1.5A	1.3A	1.3A	2.1A	2.1A
Adjustment Range	24-28V	24-28V	24-28V	24-28V	24-28V	24-28V
Output Current	0.63-0.54A	1.5-1.2A	1.3-1.1A	1.3-1.1A	2.1-1.8A	2.1-1.8A
Output Power	15W	36W	30W	30W	50W	50W
Power Reserves	-	-	-	-	-	-
Ripple & Noise max. [mV <sub>pp</sub> ]	50mV	50mV	50mV	50mV	50mV	50mV
AC Input Voltage	AC 100-240V wide range	AC 100-240V wide range	AC 100-240V wide range	AC 100-240V wide range	AC 100-240V wide range	AC 100-240V wide range
DC Input Voltage	DC 110-300V	-	DC 110-300V	DC 110-300V	DC 110-290V	DC 110-300V
Power Factor, typ.	0.44	0.46	0.53	0.49	0.52	0.52
Input Inrush Current Limiter	NTC	NTC	NTC	NTC	NTC	NTC
Input Inrush Current <sup>k)</sup>	13A/26A	19A/36A	17A/35A	18A/35A	17A/35A	17A/35A
External Input Fuse Recommendation min.	B - 6A or C - 3A	B - 6A or C - 3A	B - 10A or C - 6A	B - 6A or C - 3A	B - 10A or C - 6A	B - 10A or C - 6A
Efficiency, typ.	86.1%	> 90%	87.5%	89.4%	89.0%	88.5%
Power Losses, typ.	2.7W	3.9W	4.3W	3.7W	6.2W	6.8W
MTBF (+40°C, SN 29500)	4369 kh	TBD	650 kh	2405 kh	2613 kh	600 kh
Min. Lifetime (+40°C)	196 kh	115 kh	-	174 kh	54 kh	-
Operat. Temperature Range	-10°C to +70°C	-10°C to +70°C	-10°C to +70°C	-10°C to +70°C	-10°C to +70°C	-10°C to +70°C
Derating	0.4W/°C <sup>m)</sup>	0.9W/°C <sup>m)</sup>	0.8W/°C <sup>m)</sup>	0.8W/°C <sup>m)</sup>	1.3W/°C <sup>m)</sup>	1.3W/°C <sup>m)</sup>
Connection Terminals	screw	push-in	spring	screw	spring	screw/spring
Dimensions WxHxD	23x75x91mm	22.5x90x91mm	45x75x91mm	23x75x91mm	45x75x91mm	45x75x91mm
Weight	130g	138g	230g	140g	240g	240g
DC-OK Relay Contact	-	-	-	-	yes	yes
Special Features	Paralleloption					
Order Info	stock item		stock item	stock item	stock item	stock item
Product Family	MiniLine	PiMO	MiniLine	MiniLine	MiniLine	MiniLine
Article number	ML15.241	PIM36.241	ML30.100	ML30.241	ML50.100 ML50.109 <sup>e)</sup>	ML50.101 ML50.111 <sup>1)</sup>

1) ML50.111 with pluggable screw, parallel load distribution and a depth of 98mm

footnotes a) - m) on page 60, or click here

# 1-Phase

## 100-240V AC/DC-Converter

24V 15-91.2W



PIM36

PIM60

PIM90

ML50

ML60

CS3

QS3

NEW

NEW

24V							
2.5A	2.5A	2.5A	3A	3.3A	3.4A	3.75A	3.8A
24-28V	24-28V	24-28V	24-28V	24-28V	24-28V	24-28V	24V
2.5A	2.5-2.1A	2.5-2.1A	3-2.6A	3.3-2.7A	3.4-3A	3A	3.8A
60W	60W	60W	72W	80W	80W	90W	91.2W
-	-	-	-	-	50%	-	-
50mV	50mV	50mV	50mV	50mV	50mV	50mV	50mV
AC 100-240V wide range	AC 100-240V wide range	AC 100-240V wide range	AC 100-120V/ 220-240V manual select	AC 100-240V wide range	AC 100-240V wide range	AC 100-240V wide range	AC 100-240V wide range
-	DC 110-300V	DC 110-300V	DC 290V	DC 110-300V	DC 110-300V	-	DC 110-300V
0.47	0.5	0.44	0.54	0.56	0.47	0.45	0.90
NTC	NTC	active	NTC	NTC	active	NTC	active
36A	16A/32A	6A/6A	26A/30A	23A/45A	5A/10A	18A/40A	9A/11A
B - 6A or C - 4A	B - 10A or C - 6A	B - 6A or C - 3A	B - 10A or C - 6A	B - 10A or C - 6A	B - 6A or C - 6A	B - 6A or C - 6A	B - 6A or C - 3A
91.8%	89.7%	90.4%	91.5%	89.4%	90.0%	93.8%	92.0%
6.2/5.4W	6.9W	6.4W	8.7W	9.1W	9.1W	7.9/6.9W	7.9W
TBD	1916 kh	1866 kh	600 kh	2243 kh	1451 kh	TBD	831 kh
115kh	128 kh	90 kh	TBD	77 kh	79 kh	39kh	94 kh
-10°C to +70°C	-10°C to +70°C	-40°C to +70°C	-10°C to +70°C	-25°C to +70°C	-25°C to +70°C	-10°C to +70°C	-25°C to +70°C
1.5W/°C <sup>m)</sup>	1.5W/°C <sup>m)</sup>	1.5W/°C <sup>m)</sup>	1.8W/°C <sup>m)</sup>	1.8W/°C <sup>m)</sup>	2W/°C <sup>m)</sup>	2.3W/°C <sup>m)</sup>	2W/°C <sup>m)</sup>
push-in	screw	screw	spring	screw	spring	push-in	spring
36x90x91mm	45x75x91mm	45x75x91mm	45x75x91mm	32x124x102mm	32x124x102mm	36x90x91mm	40x124x117mm
220g	250g	250g	260g	430g	440g	270g	620g
-	-	-	-	-	-	-	yes
-40°C operation							DeviceNet approved
	stock item	stock item	stock item	stock item	stock item		stock item
PiANO	MiniLine	MiniLine	MiniLine	DIMENSION	DIMENSION	PiANO	DIMENSION
PIM60.241 PIM60.245 <sup>o)</sup>	ML60.241	ML60.242	ML70.100	CS3.241	QS3.241	PIM90.241 PIM90.245 <sup>o)</sup> PIM90.245-L1 <sup>o)g)</sup>	QS5.DNET

# 100-240V AC/DC-Converter

## 24V

## 95-240W

Output Voltage	24V						
Output Current	3.9A	4.2A	5A	5A	5A	5A	5A
Adjustment Range	24-28V	24-28V	24-28V	24-28V	24-28V	24-28V	24-28V
Output Current	3.95-3.4A	4.2-3.6A	5-4.3A	5-4.3A	5-4.3A	5-4.3A	5-4.3A
Output Power	95W	100W	120W	120W	120W	120W	120W
Power Reserves	-	-	20%	20%	20%	20%	-
Ripple & Noise max. [mV <sub>pp</sub> ]	50mV	50mV	50mV	50mV	50mV	50mV	100mV
AC Input Voltage	AC 100-120V/ 220-240V auto-select	AC 100-120V/ 220-240V auto-select	AC 100-240V wide range	AC 100-120/ 200-240V auto-select	AC 100-120V	AC 200-240V	AC 200-240V
DC Input Voltage	DC 290V	DC 290V	DC 110-150V	-	-	-	-
Power Factor, typ.	0.55	0.55	0.91	0.47	0.59	0.50	0.54
Input Inrush Current Limiter	NTC	NTC	active	active	NTC	NTC	NTC
Input Inrush Current <sup>k)</sup>	22A/37A	22A/37A	4A/3A	3A/3A	45A	30A	28A
External Input Fuse Recommendation min.	B - 10A or C - 6A	B - 10A or C - 6A	B - 6A or C - 6A	B - 10A or C - 6A	B - 16A or C - 10A	B - 16A or C - 10A	B - 10A or C - 6A
Efficiency, typ.	90.0%	90.0%	94.3%	90.2%	90.0%	90.2%	90.5%
Power Losses, typ.	10.5W	11.4W	7.3W	13.2W	13.5W	13.2W	12.6W
MTBF (+40°C, SN 29500)	500 kh	500 kh	867 kh	869 kh	740 kh	940 kh	1720 kh
Min. Lifetime (+40°C)	TBD	TBD	166 kh	72 kh	58 kh	72 kh	47 kh
Operat. Temperature Range	-10°C to +70°C	-10°C to +70°C	-25°C to +70°C	-25°C to +70°C	-10°C to +70°C	-10°C to +70°C	-10°C to +70°C
Derating	2W/°C <sup>m)</sup>	2.5W/°C <sup>m)</sup>	3W/°C <sup>m)</sup>	3W/°C <sup>m)</sup>	3W/°C <sup>m)</sup>	3W/°C <sup>m)</sup>	3W/°C <sup>l)</sup>
Connection Terminals	spring	spring	screw/spring	screw/spring	screw	screw	screw
Dimensions WxHxD	73x75x103mm	73x75x103mm	32x124x102mm	32x124x117mm	32x124x117mm	32x124x117mm	39x124x124mm
Weight	360g	360g	440g	500g	500g	500g	350g
DC-OK Relay Contact	-	-	yes	-	-	-	yes
Special Features	NEC Class 2		reduced depth				
Order Info	stock item	stock item	stock item	stock item	stock item	stock item	stock item
Product Family	MiniLine	MiniLine	DIMENSION	DIMENSION	DIMENSION	DIMENSION	PIANO
Article number	ML95.100	ML100.100 ML100.109 <sup>e)</sup>	CP5.241 CP5.242 <sup>d)</sup> CP5.241-C1 <sup>e)</sup> CP5.241-S1 <sup>b)</sup> CP5.241-S2 <sup>a)</sup>	CS5.241 CS5.241-C1 <sup>e)</sup> CS5.241-S1 <sup>b)</sup>	CS5.243	CS5.244	PIC120.241C PIC120.242C <sup>l)</sup>

footnotes a) - m) on page 60, or click here

# 1-Phase

## 100-240V AC/DC-Converter

### 24V 95-240W



CP5

CS5

CS10

QS5

CP10

PIC120

PIC240

24V							
5A	5A	8A	10A	10A	10A	10A	10A
24-28V	24-28V	24-24.5V	24-28V	24-28V	24-28V	24-28V	24-28V
5-4.3A	5-4.5A	8A	10-8.6A	10-8.6A	10-8.6A	10-8.6A	10-8.6A
120W	120W	192W	240W	240W	240W	240W	240W
-	50%	-	20%	20%	20%	20%	20%
100mV	50mV	50mV	50mV	50mV	50mV	50mV	50mV
AC 100-120V/ 200-240V auto-select	AC 100-240V wide range	AC 100-240V wide range	AC 100-240V wide range	AC 100-120V/ 200-240V auto-select	AC 100-120V/ 200-240V auto-select	AC 100-120V	AC 200-240V
-	DC 110-300V	DC 110-150V	DC 110-150V	-	-	-	-
0.54	0.91	0.92	0.97	0.51	0.57	0.59	0.52
NTC	active	active	active	active	active	NTC	NTC
22A/33A	9A/11A	4A/7A	6A/9A	3A/3A	3A/3A	85A	48A
B - 10A or C - 6A	B - 6A or C - 3A	B - 6A or C - 4A	B - 6A or C - 6A	B - 10A or C - 6A	B - 10A or C - 6A	B - 16A or C - 10A	B - 16A or C - 10A
92.3%	92.7%	93.4%	95.2%	91.6%	91.2%	91.3%	91.3%
10.0W	9.4W	13.6W	12.1W	22.0W	23.2W	22.9W	22.9W
1379 kh	831 kh	581 kh	667 kh	821 kh	821 kh	710 kh	910 kh
70 kh	89 kh	81 kh	120 kh	82 kh	75 kh	50 kh	75 kh
-10°C to +70°C	-25°C to +70°C	-25°C to +70°C	-25°C to +70°C	-25°C to +70°C	-25°C to +70°C	0°C to +70°C	0°C to +70°C
3W/°C <sup>l)</sup>	3W/°C <sup>m)</sup>	5W/°C <sup>m)</sup>	6W/°C <sup>m)</sup>	6W/°C <sup>m)</sup>	6W/°C <sup>m)</sup>	6W/°C <sup>m)</sup>	6W/°C <sup>m)</sup>
screw	spring	spring	screw/spring	screw/spring	screw	screw	screw
39x124x124mm	40x124x117mm	60x124x117mm	39x124x117mm	60x124x117mm	60x124x117mm	60x124x117mm	60x124x117mm
370g	620g	900g	600g	700g	800g	700g	700g
yes	yes	yes	yes	-	-	-	-
		DeviceNet approved			PFC version		
stock item	stock item	stock item	stock item	stock item	stock item	stock item	stock item
PIANO	DIMENSION	DIMENSION	DIMENSION	DIMENSION	DIMENSION	DIMENSION	DIMENSION
PIC120.241D	QS5.241 QS5.241-A1 <sup>f)</sup>	QS10.DNET	CP10.241 CP10.242 <sup>d)</sup> CP10.241-C1 <sup>e)</sup> CP10.241-S1 <sup>b)</sup> CP10.241-S2 <sup>a)</sup>	CS10.241 CS10.241-S1 <sup>b)</sup>	CS10.242	CS10.243	CS10.244

# 100-240V AC/DC-Converter

24V, 30V, 36V      240-480W

Output Voltage	24V						
Output Current	10A	10A	10A	20A	20A	20A	20A
Adjustment Range	24-28V	24-28V	24-28V	24-28V	24-28V	24-28V	24-28V
Output Current	10-8.6A	10-8.6A	10-9A	20-17.1A	20-17.1A	20-17.1A	20-17.1A
Output Power	240W	240W	240W	480W	480W	480W	480W
Power Reserves	-	-	50%	20%	20%	20%	-
Ripple & Noise max. [mV <sub>pp</sub> ]	100mV	100mV	50mV	50mV	50mV	50mV	100mV
AC Input Voltage	AC 200-240V	AC 100-240V wide range	AC 100-240V wide range	AC 100-240V wide range	AC 100-240V wide range	AC 100-240V wide range	AC 200-240V
DC Input Voltage	-	-	DC 110-150V	DC 110-150V	DC 110-300V	-	-
Power Factor, typ.	0.52	0.95	0.92	0.98	0.98	0.95	0.99
Input Inrush Current Limiter	NTC	active	active	active	active	active	active
Input Inrush Current <sup>k)</sup>	48A	14A/26A	4A/7A	10A/4.5A	10A/4.5A	9A/7A	26A
External Input Fuse Recommendation min.	B - 16A or C - 10A	B - 10A or C - 6A	B - 6A or C - 4A	B - 10A or C - 10A	B - 10A or C - 10A	B - 10A or C - 10A	B - 10A or C - 6A
Efficiency, typ.	91.4%	95.2%	93.5%	95.6%	95.6%	94.0%	95.7%
Power Losses, typ.	22.6W	12.1W	16.7W	22.1W	22.1W	30.6W	21.6W
MTBF (+40°C, SN 29500)	791 kh	822 kh	581 kh	590 kh	590 kh	537 kh	482 kh
Min. Lifetime (+40°C)	38 kh	74 kh	71 kh	94 kh	94 kh	88 kh	51 kh
Operat. Temperature Range	-10°C to +70°C	-25°C to +70°C	-25°C to +70°C	-25°C to +70°C	-25°C to +70°C	-25°C to +70°C	-25°C to +70°C
Derating	6W/°C <sup>l)</sup>	6W/°C <sup>l)</sup>	6W/°C <sup>m)</sup>	12W/°C <sup>m)</sup>	12W/°C <sup>m)</sup>	12W/°C <sup>m)</sup>	8W/°C <sup>l)</sup>
Connection Terminals	screw	screw	spring	screw/spring	screw/spring	screw	screw
Dimensions WxHxD	49x124x124mm	49x124x124mm	60x124x117mm	48x124x127mm	48x124x127mm	65x124x127mm	49x124x124mm
Weight	550g	540g	900g	830g	830g	1000g	620g
DC-OK Relay Contact	yes	yes	yes	yes	yes	yes	yes
Order Info	stock item	stock item	stock item	stock item	stock item	stock item	stock item
Product Family	PIANO	PIANO	DIMENSION	DIMENSION	DIMENSION	DIMENSION	PIANO
Article number	PIC240.241C	PIC240.241D	QS10.241 QS10.241-A1 <sup>f)</sup> QS10.241-C1 <sup>e)</sup> QS10.241-D1 <sup>d)</sup>	CP20.241 CP20.241-C1 <sup>e)</sup> CP20.241-S1 <sup>b)</sup> CP20.241-S2 <sup>a)</sup> CP20.241-V1 <sup>i)</sup>	CP20.242	CPS20.241 CPS20.241-C1 <sup>e)</sup> CPS20.241-D1 <sup>d)</sup>	PIC480.241C PIC480.241C-C1 <sup>e)</sup>

footnotes a) - m) on page 60, or click here



# 1-Phase

## 100-240V AC/DC-Converter

24V, 30V, 36V 240-480W



CP10

CP20

CPS20

QS10

QS20

PIC480

24V					30V	36V	
20A	20A	20A	40A	40A	8A	6.7A	13.3A
24-28V	24-28V	24-28V	24-28V	24-28V	28-32V	36-42V	36-42V
20-17.1A	20-17A	20-17A	40-34.3A	40-34.3A	8.6-7.5A	6.7-5.7A	13.3-11.4A
480W	480W	480W	960W	960W	240W	240W	480W
-	50%	50%	50%	50%	50%	20%	20%
100mV	100mV	100mV	100mV	100mV	50mV	50mV	100mV
AC 100-240V wide range	AC 100-240V wide range	AC 200-240V	AC 100-240V wide range	AC 200-240V	AC 100-240V wide range	AC 100-240V wide range	AC 100-240V wide range
-	DC 110-150V	-	-	-	DC 110-150V	DC 110-150V	-
0.97	0.90	0.50	0.99	0.96	0.92	0.97	0.95
active	active	active	active	active	active	active	active
15A/35A	9A/7A	40A	17A/11A	14A	4A/7A	6A/9A	9A/7A
B - 10A or C - 6A	B - 10A or C - 10A	B - 10A or C - 6A	B - 16A or C - 16A	B - 10A or C - 8A	B - 6A or C - 4A	B - 6A or C - 6A	B - 10A or C - 10A
95.3%	93.9%	94.5%	94.6%	94.6%	93.5%	95.4%	94.3%
23.7W	31.4W	28.3W	54.8W	54.8W	16.7W	11.6W	29.0W
704 kh	469 kh	577 kh	300 kh	366 kh	581 kh	661 kh	537 kh
102 kh	71 kh	62 kh	84 kh	59 kh	71 kh	130 kh	101 kh
-25°C to +70°C	-25°C to +70°C	-25°C to +70°C	-25°C to +70°C	-25°C to +70°C	-25°C to +70°C	-25°C to +70°C	-25°C to +70°C
12W/°C <sup>l)</sup>	12W/°C <sup>m)</sup>	12W/°C <sup>m)</sup>	24W/°C <sup>m)</sup>	24W/°C <sup>m)</sup>	6W/°C <sup>m)</sup>	6W/°C <sup>m)</sup>	12W/°C <sup>m)</sup>
screw	spring	spring	screw	screw	spring	screw	screw
59x124x127mm	82x124x127mm	70x124x127mm	125x124x127mm	125x124x127mm	60x124x117mm	39x124x117mm	65x124x127mm
810g	1200g	880g	1900g	1800g	900g	600g	1000g
yes	yes	yes	yes	yes	yes	yes	yes
stock item	stock item	stock item	stock item	stock item	stock item	stock item	stock item
PIC480	DIMENSION	DIMENSION	DIMENSION	DIMENSION	DIMENSION	DIMENSION	DIMENSION
PIC480.241D	QS20.241 QS20.241-A1 <sup>l)</sup> QS20.241-C1 <sup>e)</sup>	QS20.244	QS40.241	QS40.244	QS10.301	CP10.361	CPS20.361

# 100-240V AC/DC-Converter

36V  
48V

480-960W  
50-960W

Output Voltage	36V		48V			
Output Current	13.3A	26.7A	1.05A	2.1A	2.5A	5A
Adjustment Range	36-42V	36-42V	48-56V	48-56V	48-56V	48-52V
Output Current	13.3-11.4A	26.7-22.9A	1.05-0.9A	2.1-1.8A	2.5A	5-4.6A
Output Power	480W	960W	50W	100W	120W	240W
Power Reserves	50%	50%	-	-	20%	20%
Ripple & Noise max. [mV <sub>pp</sub> ]	100mV	130mV	200mV	50mV	50mV	100mV
AC Input Voltage	AC 100-240V wide range	AC 100-240V wide range	AC 100-240V wide range	AC 100-120V/ 220-240V auto-select	AC 100-240V wide range	AC 100-120V/ 200-240V auto-select
DC Input Voltage	DC 110-150V	-	DC 110-300V	DC 290V	DC 110-150V	-
Power Factor, typ.	0.90	0.99	0.95	-	0.91	0.51
Input Inrush Current <sup>k)</sup>	9A/7A	17A/11A	17A/35A	22A/37A	4A/4A	3A/3A
External Input Fuse Recommendation min.	B - 10A or C - 10A	B - 16A or C - 16A	B - 10A or C - 6A	B - 10A or C - 6A	B - 6A or C - 6A	B - 10A or C - 6A
Efficiency, typ.	94.0%	94.6%	90.0%	91.0%	93.5%	91.6%
Power Losses, typ.	30.6W	54.8W	6.0W	10.0W	8.4W	22.0W
MTBF (+40°C, SN 29500)	469 kh	300 kh	600 kh	500 kh	836 kh	830 kh
Min. Lifetime (+40°C)	84 kh	58 kh	-	-	166 kh	96 kh
Operat. Temperature Range	-25°C to +70°C	-25°C to +70°C	-10°C to +70°C	-10°C to +70°C	-25°C to +70°C	-25°C to +70°C
Derating	12W/°C <sup>m)</sup>	24W/°C <sup>m)</sup>	1.3W/°C <sup>m)</sup>	2.5W/°C <sup>m)</sup>	3W/°C <sup>m)</sup>	6W/°C <sup>m)</sup>
Connection Terminals	spring	screw	spring	spring	screw	screw
Dimensions WxHxD	82x124x127mm	125x124x127mm	45x75x91mm	73x75x103mm	32x124x102mm	60x124x117mm
Weight	1200g	1900g	240g	360g	440g	700g
DC-OK Relay Contact	yes	yes	-	-	yes	-
Special Features						
Order Info	stock item	stock item	stock item	stock item	stock item	stock item
Product Family	DIMENSION	DIMENSION	MiniLine	MiniLine	DIMENSION	DIMENSION
Article number	QS20.361	QS40.361	ML50.105	ML100.105	CP5.481	CS10.481

footnotes a) - m) on page 60, or click here

# 1-Phase

## 100-240V AC/DC-Converter

36V  
48V

480-960W  
50-960W



CS10

QS10

QS20

CP20

CPS20

QS40

48V							
5A	5.4A	10A	10A	10A	10A	20A	20A
48-56V	48-56V	48-56V	48-56V	48-56V	48-55V	48-54V	48-54V
5-4.3A	5.4-4.6A	10-8.6A	10-8.6A	10-8.6A	10-8.7A	20-17.8A	20-17.8A
240W	260W	480W	480W	480W	480W	960W	960W
50%	20%	20%	20%	-	50%	50%	50%
100mV	50mV	50mV	50mV	100mV	100mV	150mV	150mV
AC 100-240V wide range	AC 100-240V wide range	AC 100-240V wide range	AC 100-240V wide range	AC 100-240V wide range	AC 100-240V wide range	AC 100-240V wide range	AC 200-240V
DC 110-150V	DC 110-150V	DC 110-150V	-	-	DC 110-150V	-	-
0.92	9.98	0.95	0.95	0.97	0.90	0.99	0.96
4A/7A	6A/9A	10A/4.5A	9A/7A	15A/35A	9A/7A	17A/11A	14A
B - 6A or C - 4A	B - 6A or C - 6A	B - 10A or C - 10A	B - 10A or C - 10A	B - 10A or C - 6A	B - 10A or C - 10A	B - 16A or C - 16A	B - 10A or C - 8A
92.0%	95.5%	96.0%	93.9%	95.7%	94.3%	95.0%	95.0%
20.9W	12.3W	20.0W	31.2W	21.6W	29.0W	50.5W	50.5W
606 kh	699 kh	TBD	537 kh	704 kh	469 kh	300 kh	392 kh
81 kh	120 kh	118 kh	87 kh	138 kh	92 kh	90 kh	65 kh
-25°C to +70°C	-25°C to +70°C	-25°C to +70°C	-25°C to +70°C	-25°C to +70°C	-25°C to +70°C	-25°C to +70°C	-25°C to +70°C
6W/°C <sup>m)</sup>	6.5W/°C <sup>m)</sup>	12W/°C <sup>m)</sup>	12W/°C <sup>m)</sup>	12W/°C <sup>l)</sup>	12W/°C <sup>m)</sup>	24W/°C <sup>m)</sup>	24W/°C <sup>m)</sup>
spring	screw	screw	screw	screw	spring	screw	screw
60x124x117mm	39x124x117mm	48x124x127mm	65x124x127mm	59x124x127mm	82x124x127mm	125x124x127mm	125x124x127mm
900g	600g	820g	1000g	810g	1200g	1900g	1800g
yes	yes	yes	yes	yes	yes	yes	yes
stock item	stock item	stock item	stock item	stock item	stock item	stock item	stock item
DIMENSION	DIMENSION	DIMENSION	DIMENSION	PIANO	DIMENSION	DIMENSION	DIMENSION
QS10.481 QS10.481-D1 <sup>d)</sup>	CP10.481	CP20.481	CPS20.481 CPS20.481-D1 <sup>d)</sup>	PIC480.481D	QS20.481	QS40.481	QS40.484

# 380-480V AC/DC-Converter

12V, 24V  
36V, 48V, 72V

90-960W  
240-960W

Output Voltage	12V	24V					
Output Current	8A	3.75A	4.2A	5A	10A	20A	40A
Adjustment Range	12-15V	24-28V	24-28V	24-28V	24-28V	24-28V	24-28V
Output Current	8-6.4A	3.75-3.2A	4.2-3.6A	5-4.3A	10-8.6A	20-17.5A	40-34.3A
Output Power	96W	90W	100W	120W	240W	480W	960W
Power Reserves	-	-	-	20%	20%	50%	50%
Ripple & Noise max. [mV <sub>pp</sub> ]	100mV	50mV	50mV	50mV	50mV	100mV	100mV
<b>AC Input Voltage</b>	<b>2AC 380-480V wide range</b>	<b>2AC 380-480V wide range</b>	<b>2AC 380-480V wide range</b>	<b>2AC 380-480V wide range</b>	<b>3AC 380-480V wide range</b>	<b>3AC 380-480V wide range</b>	<b>3AC 380-480V wide range</b>
Power Factor, typ.	0.44	0.60	0.60	0.45	0.53	0.94	0.88
Input Inrush Current Limiter	active	NTC	NTC	active	active	active	active
Input Inrush Current <sup>k)</sup>	4A/4A <sup>e)</sup>	36A/45A	36A/45A	4A/4A	4A/4A	3A/3A	4.5A/4.5A
External Input Fuse Recommendation min.	B - 6A or C - 3A	B - 10A or C - 6A	B - 10A or C - 6A	B - 6A or C - 3A	B - 6A or C - 3A	B - 6A or C - 3A	B - 6A or C - 6A
Efficiency, typ.	85.4%	89.5%	89.5%	90.4%	92.8%	95.0%	95.3%
Power Losses, typ.	16.4W	10.5W	11.7W	12.7W	18.6W	25.3W	47.3W
MTBF (+40°C, SN 29500)	983 kh	1594 kh	1594 kh	1173 kh	975 kh	690 kh	375 kh
Min. Lifetime (+40°C)	51 kh	-	-	92 kh	54 kh	105 kh	69 kh / 93 kh
Operat. Temperature Range	-25°C to +70°C	-10°C to +70°C	-10°C to +70°C	-25°C to +70°C	-25°C to +70°C	-25°C to +70°C	-25°C to +70°C
Derating	2.5W/°C <sup>m)</sup>	2W/°C <sup>m)</sup>	2.5W/°C <sup>m)</sup>	3W/°C <sup>m)</sup>	6W/°C <sup>m)</sup>	12W/°C <sup>m)</sup>	24W/°C <sup>m)</sup>
Connection Terminals	screw	spring	spring	screw	screw	spring	screw
Dimensions WxHxD	40x124x117mm	72.5x75x103mm	72.5x75x103mm	40x124x117mm	62x124x117mm	65x124x127mm	110x124x127mm
Weight	500g	360g	360g	500g	750g	870g	1500g
DC-OK Relay Contact	-	-	-	-	-	yes	yes
Special Features		NEC Class 2					
Order Info	stock item	stock item	stock item	stock item	stock item	stock item	stock item
Product Family	<b>DIMENSION</b>	MiniLine	MiniLine	<b>DIMENSION</b>	<b>DIMENSION</b>	<b>DIMENSION</b>	<b>DIMENSION</b>
<b>Article number</b>	<b>CT5.121</b>	<b>ML90.200</b>	<b>ML100.200</b>	<b>CT5.241</b>	<b>CT10.241</b> CT10.241-C1 <sup>e)</sup>	<b>QT20.241</b> QT20.241-C1 <sup>e)</sup>	<b>QT40.241</b> QT40.242 <sup>h)</sup>

1) Separate units for 3AC 400V and 3AC 480V required, use XT40.241, XT40.361, XT40.481, XT40.721 for 3AC 400V mains

2) Separate units for 3AC 400V and 3AC 480V required, use XT40.242, XT40.362, XT40.482, XT40.722 für 3AC 480V mains

footnotes a) - m) on page 60, or click here

# 3-Phase

## 380-480V AC/DC-Converter

12V, 24V 90-960W

36V, 48V, 72V 240-960W



ML90 / ML100

CT5

CT10

QT20

QT40

XT40

24V	36V			48V			72V	
40A	13.3A	26.6A	26.7A	5A	10A	20A	20A	13.3A
24V	36-42V	36V	36-42V	48-56V	48-55V	48-54V	48V	72V
40A	13.3A	26.6A	26.7-22.9A	5-4.3A	10A	20-17.8A	20A	13.3A
960W	480W	960W	960W	240W	480W	960W	960W	960W
25%	50%	25%	50%	20%	50%	50%	25%	25%
1500mV	100mV	2000mV	130mV	100mV	100mV	150mV	2500mV	3000mV
3AC 400V 3AC 480V	3AC 380-480V wide range	3AC 400V 3AC 480V	3AC 380-480V wide range	3AC 380-480V wide range	3AC 380-480V wide range	3AC 380-480V wide range	3AC 400V 3AC 480V	3AC 400V 3AC 480V
0.93	0.94	0.93	0.88	0.53	0.94	0.88	0.93	0.93
active	active	active	active	active	active	active	active	active
2A	3A/3A	2A	4.5A/4.5A	4A/4A	3A/3A	4.5A/4.5A	2A	2A
B - 6A or C - 3A	B - 6A or C - 3A	B - 6A or C - 3A	B - 6A or C - 6A	B - 6A or C - 3A	B - 6A or C - 3A	B - 6A or C - 6A	B - 6A or C - 3A	B - 6A or C - 3A
95.5%	94.8%	95.5%	95.3%	92.8%	95.4%	95.4%	96.0%	95.5%
45.2W	26.3W	45.2W	47.3W	18.6W	23.1W	46.3W	40.0W	45.2W
529 kh	690 kh	529 kh	375 kh	1019 kh	690 kh	375 kh	541 kh	539 kh
51 kh	51 kh	55 kh	71 kh	114 kh	51 kh	86 kh	77 kh	55 kh
-25°C to +70°C	-25°C to +70°C	-25°C to +70°C	-25°C to +70°C	-25°C to +70°C	-25°C to +70°C	-25°C to +70°C	-25°C to +70°C	-25°C to +70°C
24W/°C <sup>m)</sup>	12W/°C <sup>m)</sup>	24W/°C <sup>m)</sup>	24W/°C <sup>m)</sup>	6W/°C <sup>m)</sup>	12W/°C <sup>m)</sup>	24W/°C <sup>m)</sup>	24W/°C <sup>m)</sup>	24W/°C <sup>m)</sup>
screw	spring	screw	screw	screw	spring	screw	screw	screw
96x124x159mm	65x124x127mm	96x124x159mm	110x124x127mm	62x124x117mm	65x124x127mm	110x124x127mm	96x124x159mm	96x124x159mm
1400g	870g	1400g	1500g	750g	870g	1500g	1400g	1400g
-	yes	-	yes	-	yes	yes	-	-
semi-regulated	semi-regulated						semi-regulated	semi-regulated
stock item	stock item	stock item	stock item	stock item	stock item	stock item	stock item	stock item
DIMENSION	DIMENSION	DIMENSION	DIMENSION	DIMENSION	DIMENSION	DIMENSION	DIMENSION	DIMENSION
XT40.241 <sup>1)</sup> XT40.242 <sup>2)</sup>	QT20.361	XT40.361 <sup>1)</sup> XT40.362 <sup>2)</sup>	QT40.361	CT10.481	QT20.481	QT40.481	XT40.481 <sup>1)</sup> XT40.482 <sup>2)</sup>	XT40.721 <sup>1)</sup> XT40.722 <sup>2)</sup>

# DC/DC converter

There are multiple applications for DC/DC-converters:

- Serves as stabilised control voltage in battery powered applications
- For galvanic isolation in mobile applications e.g. for ships or fork-lifts
- To avoid earth ground loops
- To restore control voltage at the end of long wires, to compensate for voltage drops

Nominal Input Voltage	DC 12V	DC 24V			
Output Voltage Range	23-28V	12-15V	23-28V	23-28V	24V
DC Input Voltage	DC 12V	DC 24V	DC 24V	DC 24V	DC 24V
Output Current	4-3.4A	8-6.4A	5-4.3A	5-4.3A	3.8A
Output Power	96W	96W	120W	120W	92W
Power Reserves	20%	20%	20%	20%	-
Ripple & Noise max. [mV <sub>pp</sub> ]	50mV	75mV	50mV	50mV	50mV
Efficiency, typ.	87.7%	88.2%	90.3%	90.2%	90.5%
Power Losses, typ.	13.5W	12.8W	12.9W	13.3W	9.7W
MTBF (+40°C, SN 29500)	1056 kh	1161 kh	1178 kh	1048 kh	1487 kh
Min. Lifetime (+40°C)	73 kh	63 kh	65 kh	60 kh	134 kh
Operat. Temperature Range	-25°C to +70°C	-25°C to +70°C	-25°C to +70°C	-25°C to +70°C	-25°C to +70°C
Derating	2.5W/°C <sup>(m)</sup>	2.5W/°C <sup>(m)</sup>	3W/°C <sup>(m)</sup>	3W/°C <sup>(m)</sup>	-
Connection Terminals	screw	screw	screw	spring	spring
Dimensions WxHxD	32x124x102mm	32x124x102mm	32x124x102mm	32x124x102mm	32x124x102mm
Weight	435g	425g	425g	450g	425g
Special Features				DC-OK- and input-low-relay contacts	NEC Class 2
Order Info	stock item	stock item	stock item	stock item	stock item
Product Family	DIMENSION	DIMENSION	DIMENSION	DIMENSION	DIMENSION
Article number	CD5.243	CD5.121	CD5.241	CD5.241-S1	CD5.241-L1

footnotes a) - m) on page 60, or [click here](#)

# DC/DC

DC/DC-Converter  
12, 24, 48-56 VDC  
110-600 VDC



CD5

CD10

QTD20

DC 24V	DC 48V			DC 600V
23-28V	23-28V	24-28V	48-56V	24-28V
DC 24V	DC 48V	DC 48V	DC 48V	DC 600V
10-8.6A	5-4.3A	10A	5-4.3A	20-17.5A
240W	120W	240W	240W	480W
20%	20%	20% <sup>1)</sup>	20%	25%
50mV	50mV	50mV <sup>1)</sup>	100mV	100mV
94.2%	90.3%	94.0% <sup>1)</sup>	95.1%	95.0%
14.8W	12.9W	15.3W <sup>1)</sup>	12.4W	25.5W
TBD	951 kh	TBD	TBD	446 kh
80 kh	64 kh	TBD	160 kh	42 kh
-25°C to +70°C	-25°C to +70°C	-25°C to +70°C	-25°C to +70°C	-25°C to +70°C
6W/°C <sup>m)</sup>	3W/°C <sup>m)</sup>	6W/°C	6W/°C <sup>m)</sup>	12W/°C <sup>m)</sup>
screw	screw	screw	screw	spring
42x124x117mm	32x124x102mm	42x124x117mm	42x124x117mm	65x124x127mm
500g	425g	500g	500g	890g
				intermediate DC-bus
stock item	stock item		stock item	stock item
DIMENSION	DIMENSION	DIMENSION	DIMENSION	DIMENSION
CD10.241	CD5.242	CD10.242	CD10.482	QTD20.241

# Railway



## Reliable, efficient and robust

- EN 50155 certified
- 100% higher mains-failure bridging time than required by railway standard EN 50155 (S2)
- Weather-resistant: All devices have PC boards with a conformal coating
- Minimal noise generation: 100% convection-cooled
- Flexible use, rapid replacement: DIN rail mounting

## EN 50155-certified

- EN 50155 **Electronic equipment used on rolling stock** classified according to T3, TX, C2 and S2
- EN 61373 **Shock and vibration tests** classified according to Cat.1, Class B
- EN 50121-3-2 **EMC** requirements
- EN 45545-2 **Fire protection requirements** according to Hazard Level HL3

Output Voltage Range	24-28V	24-28V	24-28V	24.5V
Input Voltage	DC 110V -30%/+40%	DC 96-110V -30%/+40%	DC 110V -30%/+40%	DC 110V -30%/+40%
Output Current	4.2-3.6A	8.3-7.1A	8.3-7.1A	16.3A
Output Power	100W	200W	200W	400W
Power Reserves	50%	-	50%	-
Ripple & Noise max. [mV <sub>pp</sub> ]	50mV	50mV	50mV	70mV
Efficiency, typ.	91.1%	94.5%	93%	93.7%
Power Losses, typ.	9.8W	11.6W	15W	26.9W
MTBF (+40°C, SN 29500)	956 kh	775 kh	688 kh	571 kh
Min. Lifetime (+40°C)	127 kh	119 kh	266 kh	151 kh
Operat. Temperature Range	-25°C to +70°C	-40°C to +70°C	-40°C to +70°C	-40°C to +70°C
Derating	-	-	-	-
Connection Terminals	spring	spring	spring	spring
Dimensions WxHxD	40x124x117mm	39x124x117mm	60x124x117mm	65x124x127mm
Weight	640g	600g	920g	980g
Order Info	stock item	stock item	stock item	stock item
<b>Article number</b>	<b>QS5.241-60</b>	<b>CP10.241-60</b>	<b>QS10.241-60</b>	<b>CPS20.241-60</b>



## Medical

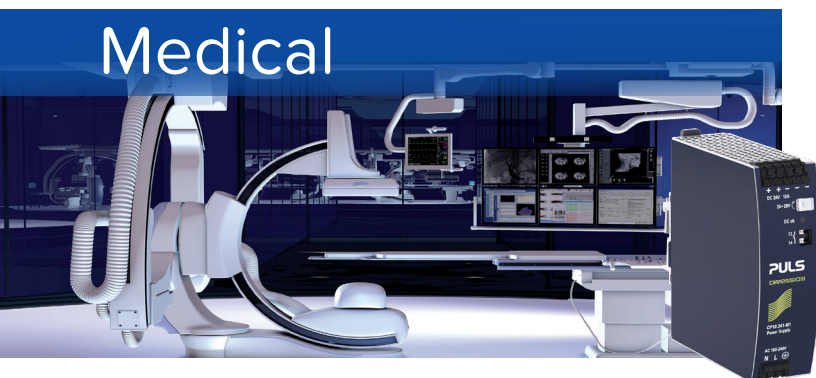

### Maximum protection for patients and users

- **IEC 60601-1, 3<sup>rd</sup> Edition**  
Requirements for electrical safety on medical devices or systems
- **2 MOPP (Means Of Patient Protection)**  
Duplications of measures for patient protection
- **IEC 60601-1-2, 4<sup>th</sup> Edition**  
Product standard for the EMC test on medical devices or systems

<b>Output Voltage Range</b>	<b>24-28V</b>
<b>Output Current</b>	<b>10-8.6A</b>
Output Power / Power Reserves	240W / 20%
Ripple & Noise max. [mVPP]	50mV
AC Input Voltage	AC 100-240V wide range
Power Factor, typ.	0.97
Input Inrush Current Limiter	active
Input Inrush Current <sup>k)</sup>	6A/9A
Ext. Input Fuse Recommendation	B - 6A or C - 6A
DC Input Voltage	DC 110-150V
Efficiency, typ. / Power Losses, typ.	95.2% / 12.1W
MTBF (+40°C, SN 29500)	661 kh
Min. Lifetime (+40°C)	120 kh
Operat. Temperature Range	-25°C to +70°C
Derating +60°C to +70°C	6W/°C
Connection Terminals	spring
Dimensions WxHxD	39x124x117mm
Weight	620g
DC-OK Relay Contact	yes
Order Info	stock item
<b>Article number</b>	<b>CP10.241-M1</b>

## Marine



<b>Output Voltage Range</b>	<b>24V</b>
<b>Output Current</b>	<b>20A</b>
Output Power / Power Reserves	480W / 20%
Ripple & Noise max. [mVPP]	100mV
AC Input Voltage	100-240V
Power Factor, typ.	0.98
Input Inrush Current Limiter	active
Input Inrush Current <sup>k)</sup>	10A/4.5A
Ext. Input Fuse Recommendation	B - 10A or C - 10A
DC Input Voltage	DC 110-150V
Efficiency, typ. / Power Losses, typ.	95.2% / 24.2W
MTBF (+40°C, SN 29500)	543 kh
Min. Lifetime (+40°C)	90 kh
Operat. Temperature Range	-40°C to +70°C
Derating +60°C to +70°C	12W/°C
Connection Terminals	plug
Dimensions WxHxD	48x124x127mm no plug
Weight	850g
DC-OK Relay Contact	yes
<b>Article number</b>	<b>CP20.245-R2</b>

### Reliable use on the bridge and on deck:

- **DNV, EMC class B**  
This product can be used on the entire ship – including the bridge and deck without having to use any additional filter
- **Integrated decoupling function**  
Applicable for the construction of redundant systems
- **Hot-swap plug connector**  
Enables the exchange of devices without causing a system shutdown

**Info:** Other suitable DIN rail power supplies with regards to shipbuilding and offshore areas can be found on page 50-55. This is where regulatory and approval notes are explained.



# Application Analysis Tool

The new SmartFab Box was developed to bring more transparency to the power requirements and thermal conditions in applications. Users can now check and specify their power budgets directly in their application. This knowledge helps in selecting the right power supply and avoiding over-sized power reserves.



## How the SmartFab Box works

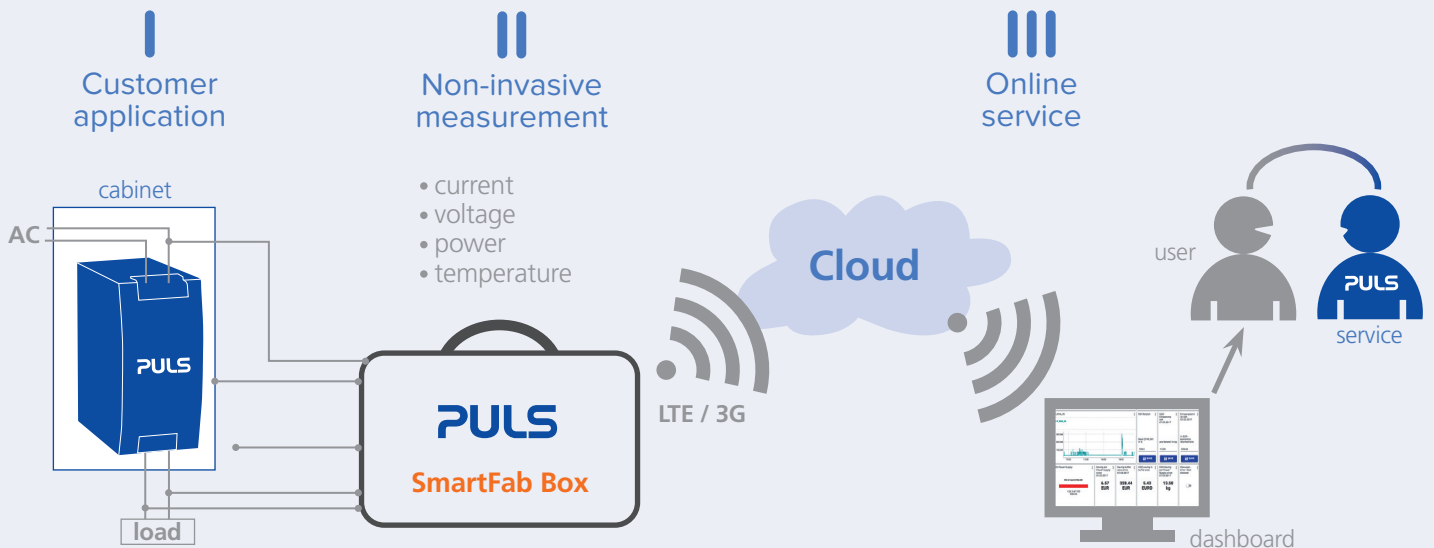

## Benefits of the SmartFab Box:

- **Transparent power data**  
The temperature, voltage and current measurements are displayed close to real-time readings.
- **Fast and safe to operate**  
VPN connection via LTE/3G. There is no need to connect the SmartFab Box to the local corporate network. The non-invasive installation and measurement do not influence the application.
- **Reliable and confidential**  
No data loss in case of power failure. Data backup is anonymously stored on a cloud server located in Germany.

## Rent or buy the SmartFab Box:

Email: [smartfabbox@powersupply.cloud](mailto:smartfabbox@powersupply.cloud)

## Technical requirements:

- AC-mains
- LTE/3G network coverage
- Supported browsers: Google Chrome, Mozilla Firefox, Internet Explorer, Safari

# Power-over-Ethernet (PoE)



The new PoE solutions are available in combination with an integrated power supply (PoE injector with AC input) or as a standalone module (PoE injector with DC input). The devices are optimised for plug and play, and automatically detect the performance class of the connected components (IEEE 802.3at/af). Thanks to its high performance (PoE+ and Gigabit Ethernet), reliability and efficiency as well as the robust device design, the PoE power supplies and injectors are ideal for flexible use in numerous applications: e.g. process and production automation, medical technology as well as monitoring systems and infrastructure.

## Highlights

➔ PoE+ 30W per port ➔ 1Gbit/s Ethernet ➔ DIN rail mounting ➔ Version with integrated high-end power supply

### PoE Power Supply (AC input)

Output	
PoE standard	PoE+ (IEEE 802.3at) PoE (IEEE 802.3af)
Output Current	30W per port (25.5W on the load)
Output Voltage	48V – 56V per port (adjustable)
Input (integrated power supply: CP10.481)	
AC Input Voltage nominal	100V – 240V
AC input voltage range	90V – 264V
Power Factor	0.98
Input Inrush Current	6A / 9A (120 / 230V)
DC Input Voltage, nominal	110V – 150V
DC Input Voltagesbereich	88V – 187V
Efficiency (CP10.481)	95.5%
MTBF SN 29500, IEC 61709 (CP10.481)	699kh
Lifetime expectancy (CP10.481)	> 109kh
General Data	
Data transfer rate	Gigabit Ethernet
Connection terminal type	Plug connector, RJ45 Ethernet
Dimensions WxHxD	77 x 131 x 117mm
Weight	900g
Operating temperature	-25°C to +70°C
Article number	<b>POE.8AT-AC1</b> <b>POE.4AT-AC1</b>
	8 ports                      4 ports (available soon)

### PoE Injector (DC input)

Output	
PoE standard	PoE+ (IEEE 802.3at) PoE (IEEE 802.3af)
Output Current	30W per port (25.5W on the load)
Output Voltage	48V – 56V per port (adjustable)
Input	
DC input voltage range	48V – 56V
Input Inrush Current	5.5A
General Data	
Data transfer rate	Gigabit Ethernet
Connection terminal type	Plug connector, RJ45 Ethernet
Dimensions WxHxD	39 x 128 x 117mm
Weight	360g
Operating temperature	-45°C to +85°C
Article number	<b>POE.8AT-DC1</b> <b>POE.4AT-DC1</b>
	8 ports                      4 ports (available soon)



# Redundancy

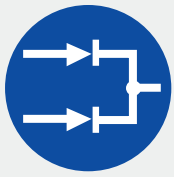

## Power Supplies with Integrated Decoupling Function

### Redundant systems without redundancy modules.

With the CP series, PULS offers a unique feature: Power supplies with an integrated decoupling function based on efficient MOSFET technology. This means there is no need for additional redundancy modules in 1+1 and n+1 redundant systems. These units are available with plug connectors for hot-swap applications or with screwless terminals.

### Space-savings

PULS managed to integrate the decoupling feature into the standard CP-housings. This means the dimensions of the units are identical to those of the standard CP10 (39mm) and CP20 (48mm). The slim units and the elimination of the redundancy module allow space-savings of more than 45%.

### Hot-swap

The new power supplies are available with hot-swap plug connectors or screwless terminals. The hot-swap connectors (CP10.241-R2 and CP20.241-R2) allow the replacement of devices during ongoing operation. If there is no need for this feature or if heavy shocks and vibrations occur regularly in the application, the screwless units (CP10.241-R1 and CP20.241-R1) are the perfect choice.

### Keep the system simple

The power supplies reduce system complexity and costs due to shorter installation times. Less cabling effort also means a lower failure risk caused by faulty connections. In addition there is only one part number that has to be managed.

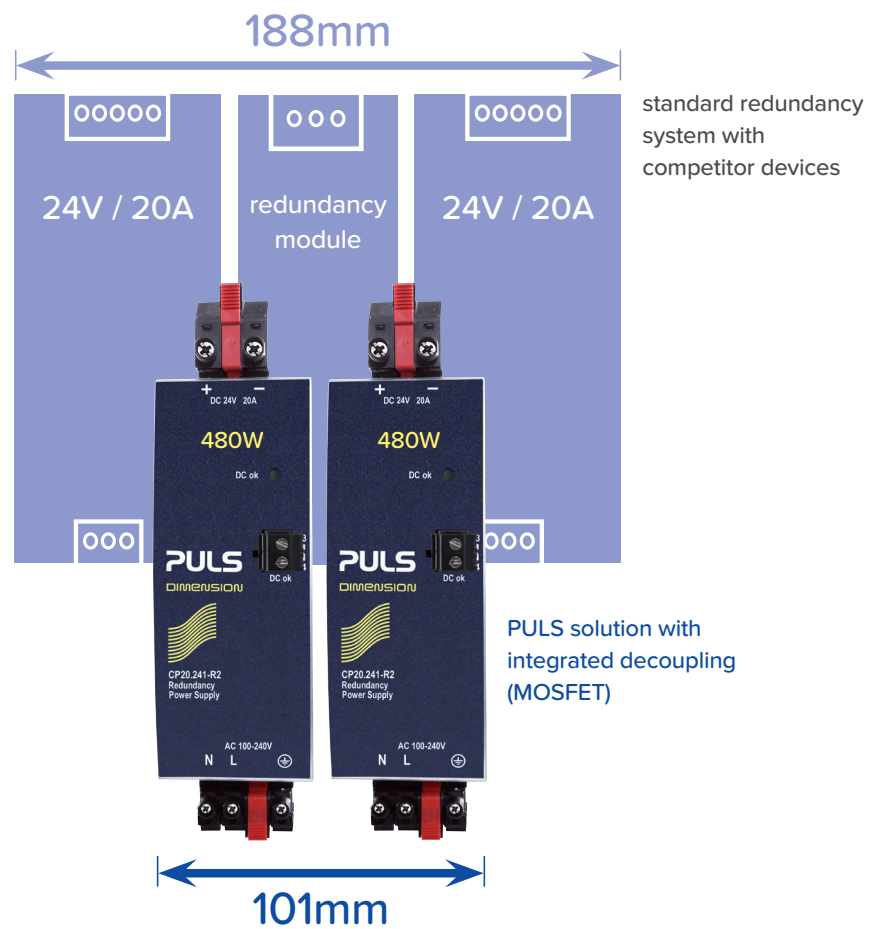

# Power Supplies with Integrated Decoupling

## 240-480W



NEW

<b>Output Voltage</b>	<b>24V</b>			<b>24V</b>		
<b>Output Current</b>	<b>10A</b>			<b>20A</b>		
Adjustment Range	fixed			fixed		
Output Current bei +60°C Umgebungstemperatur	10A			20A		
Output Power	240W			480W		
Power Reserves	20%			20%		
Ripple & Noise max. [mVPP]	50mV			50mV	50mV	100mV
AC Input Voltage	AC 100-240V wide range			AC100-240V wide range		
Power Factor, typ.	0.97			0.95	0.95	0.98
Input Inrush Current Limiter	active			active		
Input Inrush Current	6A/9A			10A/4.5A		
Ext. Input Fuse Recommendation	B - 6A or C - 6A			B - 10A or C - 10A		
DC Input Voltage	DC 110-150V	DC 110-150V	DC 110-300V	DC 110-150V	DC 110-150V	DC 110-300V
Efficiency, typ.	94.9%			95.2%		
Power Losses, typ.	13.4W			24.2W		
MTBF (+40°C, SN 29500)	641 kh			543 kh		
Min. Lifetime (+40°C)	109 kh			90 kh		
Operat. Temperature Range	-25°C to +70°C			-40°C to +70°C		
Derating +60°C to +70°C	6W/°C			12W/°C		
Dimensions WxHxD	39x124x117mm			48x124x127mm		
Weight	600g			820g	850g	850g
DC-OK Relay Contact	yes			yes		
Connection Terminals	spring	plug	plug	spring	plug	plug
Hot-Swap	no	yes	yes	no	yes	yes
Order Info	lead time on request	stock item	stock item	lead time on request	stock item	stock item
Product Family	DIMENSION	DIMENSION	DIMENSION	DIMENSION	DIMENSION	DIMENSION
<b>Article number</b>	<b>CP10.241-R1</b>	<b>CP10.241-R2</b> CP10.241-R2-C1 <sup>1)</sup>	<b>CP10.242-R2</b>	<b>CP20.241-R1</b>	<b>CP20.241-R2</b> CP20.241-R2-C1 <sup>1)</sup>	<b>CP20.242-R2</b>

1) Conformal coating / on request

# Redundancy Modules

## Highest System Reliability

In a redundant power supply system, two or more power supplies are wired in parallel to increase the reliability and availability of the DC voltage by having a second power supply as backup in case one power supply fails.

Both power supplies are decoupled by one or more redundancy modules to isolate each power supply and to guarantee that the non-functional power supply does not prevent the working units from providing the constant DC voltage for the demanding application.

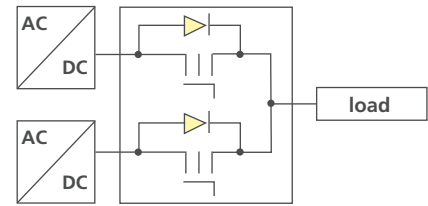

1+1-redundancy

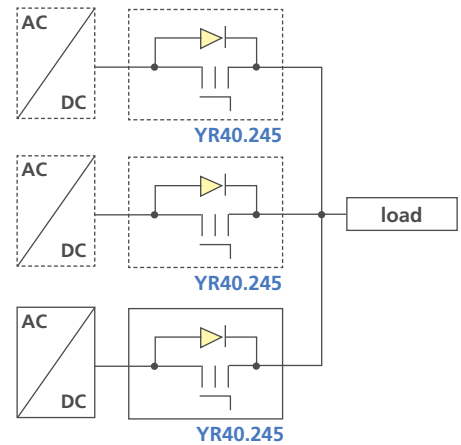

N+1-redundancy

Nominal Voltage	DC 12-28V	DC 12-48V		DC 24-48V	
Input / Output	2x 10A / 20A	2x 5A / 10A	2x 5A / 10A	2x 10A / 20A	2x 10A / 20A
Input Voltage Range	DC 9-35V	DC 9-60V	DC 9-60V	DC 9-60V	DC 18-60V
Nominal Current per Input <sup>1)</sup>	10A	5A	5A	10A	10A
Output Current Nominal Current <sup>1)</sup> Short Circuit <sup>2)</sup>	20A max. 26A	10A max. 16A	10A max. 16A	20A max. 25A	20A max. 25A
Voltage Drop <sup>3)</sup> In- / Output	460mV	800mV	800mV	800mV	780mV
Decoupling	diode	diode	diode	diode	diode
Power Losses No Load Nominal Load <sup>3)</sup>	0W 4.6W	0W 4.0W	0W 4.0W	0W 8.0W	1W 8.8W
MTBF (+40°C, SN 29500)	7.8 Mio. h	85 Mio. h	85 Mio. h	46 Mio. h	9.1 Mio. h
Min. Lifetime (+40°C)	113 kh	218 kh	218 kh	218 kh	218 kh
Operat. Temperature Range	-40°C to +70°C	-40°C to +70°C	-40°C to +70°C	-40°C to +70°C	-40°C to +70°C
Derating	0.5A/°C <sup>l)</sup>	0.25A/°C <sup>m)</sup>	0.25A/°C <sup>m)</sup>	0.5A/°C <sup>m)</sup>	0.5A/°C <sup>m)</sup>
Dimensions WxHxD	39x124x124mm	45x75x91mm	45x75x91mm	32x124x102mm	32x124x117mm
Weight	280g	140g	140g	290g	350g
Connection Terminals	screw	screw	spring	spring	screw
Special Features					
Order Info	stock item	stock item	stock item	stock item	stock item
Product Family	PIANO	MiniLine	MiniLine	DIMENSION	DIMENSION
Article number	PIRD20.241	MLY10.241	MLY02.100	YR2.DIODE	YRM2.DIODE

1) 50% higher currents are allowed up to 5s 2) Current at voltage <6V

3) 1+1-redundancy (= 50% of the nominal current) and symmetrical input currents



## DIMENSION YR20.246 | 24V, 2 x 10A

### High-efficient decoupling

- Automated load share feature**  
 Compensates a certain voltage unbalance between the two power supplies connected to the inputs. Benefits: Perfect temperature balance, longer lifetime and lower operational costs
- Efficient MOSFET technology**  
 Very low power losses and reduced voltage drop
- Redundancy OK signal**  
 Monitoring of the redundancy and notification in case of an error or failure



## PIANO PIRD20.241 | 24V, 2 x 10A

### Cost-oriented decoupling

- Cost-oriented diode technology**  
 Economically priced 1+1 and n+1 redundancy solutions
- Compact and robust design**  
 39mm width and wide operating temperature range from -40°C to +55°C without derating

DC 12-28V						DC 24-28V	DC 24-56V
2x 20A / 40A	2x 20A / 20A	2x 20A / 40A	1x 40A / 40A	2x 40A / 80A	2x 40A / 80A	2x 10A / 20A	2x 20A / 40A
DC 8.4-36.4 V	DC 8.4-36.4 V	DC 8.4-36.4V	DC 8.4-36.4V	DC 8.4-36.4V	DC 8.4-36.4V	DC 18-35 V	DC 20.4-64.4V
20A	10A	20A	40A	40A	40A	10A	20A
40A max. 26A	20A max. 26A	40A max. 65A	40A max. 22A	80A max. 130A	80A max. 44A	20A max. 26A	40A max. 45A
72mV	60mV	72mV	80mV (at 1x20A) 150mV (at 40A)	49mV	65mV	100 - 500mV	60mV
MOSFET	MOSFET	MOSFET	MOSFET	MOSFET	MOSFET	MOSFET	MOSFET
0.23W 1.7W	0.21W 0.6W	0.7W 2.15W	0.1W 1.8W (at 1x20A) 6.2W (at 40A)	0.7W 2.7W	0.2W 2.9W	1.7W 2.6 - 4.7W	0.62W 1.8W
4.5 Mio. h	7.9 Mio. h	2.7 Mio. h	6.4 Mio. h	2.1 Mio. h	2.5 Mio. h	2 Mio. h	4.1 Mio. h
255 kh	355 kh	246 kh	134 kh	143 kh	85 kh	182 kh	222 kh
-40°C to +70°C	-40°C to +70°C	-40°C to +70°C	-40°C to +70°C	-40°C to +70°C	-40°C to +70°C	-40°C to +70°C	-40°C to +70°C
1A/°C <sup>m)</sup>	1A/°C <sup>m)</sup>	not required	1A/°C <sup>m)</sup>	not required	2A/°C <sup>m)</sup>	not required	1A/°C <sup>m)</sup>
36x124x127mm	32x124x117mm	36x124x127mm	46x124x127mm	46x124x127mm	46x124x127mm	32x124x117mm	46x124x127mm
280g	250g	340g	340g	440g	370g	310g	360g
screw	screw	screw	screw, plug connection	screw	screw	screw	screw
not suitable for QT20, QTD20			not suitable for QT40		not suitable for QT40		
stock item	lead time on request	stock item	stock item	stock item	stock item	lead time on request	stock item
DIMENSION	DIMENSION	DIMENSION	DIMENSION	DIMENSION	DIMENSION	DIMENSION	DIMENSION
YR40.242	YR20.242	YR40.241	YR40.245	YR80.241	YR80.242	YR20.246	YR40.482

footnotes a) - m) on page 60, or click here

# Protection Modules

PISA is a new and innovative low-cost concept for current distribution and protection of 24V load circuits. First, it distributes the current of a large power source to four lower current output channels and therefore allows for smaller wires to be used.

The second function is to permit only as much current on the outputs so that the input voltage of this unit (which corresponds to the output voltage of the power supply) does not fall below 21V. This ensures a safe and uninterrupted supply voltage for sensitive equipment, such as PLCs, controls or sensors, when they are connected directly to the same power supply as the PISA module.

Less critical loads, that are not affected by short voltage interruptions or that could even be the cause of a fault on the 24V power supply are connected to one of the four current controlled output channels of the PISA module. The protection is independent of the length of the wires or of the power supplies' characteristics.

Output Current	Channel 1	Channel 2	Channel 3	Channel 4	
	1A	2A	3A	4A	6A
	1A	2A	3A	4A	6A
	1A	2A	3A	4A	6A
	1A	2A	3A	4A	6A
Nominal Voltage	DC24-28V	DC24-28V	DC24-28V	DC24-28V	DC24-28V
Input Voltage Range	18-30Vdc	18-30Vdc	18-30Vdc	18-30Vdc	18-30Vdc
Required Input Voltage for Turning-On the Outputs, typ.	21.4Vdc	21.4Vdc	21.4Vdc	21.4Vdc	21.4Vdc
Turn-On Delay of Outputs	270ms	270ms	270ms	270ms	270ms
Input Voltage Protection Level min./max.	21.0Vdc/21.8Vdc	21.0Vdc/21.8Vdc	21.0Vdc/21.8Vdc	21.0Vdc/21.8Vdc	21.0Vdc/21.8Vdc
Output Current (All 4 Outputs)	4A	8A	12A	16A	20A
Output Current Limitation min./max.	9A/12.7A	9A/12.7A	16.6A/23.6A	16.6A/23.6A	20.5A/30A
Shutdown-Times at Short Circuit, typ.	110ms	110ms	10ms	10ms	8ms
Voltage Drop, typ.	41mV	83mV	75mV	101mV	124mV
Input Current at No Load, typ.	43mA	43mA	43mA	43mA	43mA
No-Load Losses, typ.	1.0W	1.0W	1.0W	1.0W	1.0W
Power Losses, typ.	1.0W	1.3W	1.4W	1.8W	2.4W
MTBF (+40°C, SN 29500)	2347 kh	2323 kh	2283 kh	2114 kh	1942 kh
Lifetime (min. at +40°C)	243 kh	233 kh	229 kh	216 kh	203 kh
Operat. Temperature Range	-25°C to +70°C	-25°C to +70°C	-25°C to +70°C	-25°C to +70°C	-25°C to +70°C
Derating Each Channel	-	-	-	0.025A/°C	0.025A/°C
Dimensions WxHxD	45x75x91mm	45x75x91mm	45x75x91mm	45x75x91mm	45x75x91mm
Weight	120g	120g	120g	120g	120g
Connection Terminals	screw	screw	screw	screw	screw
Product Status	stock item	stock item	stock item	stock item	stock item
Product Family	DIMENSION	DIMENSION	DIMENSION	DIMENSION	DIMENSION
Article number	PISA11.401	PISA11.402	PISA11.403	PISA11.404	PISA11.406



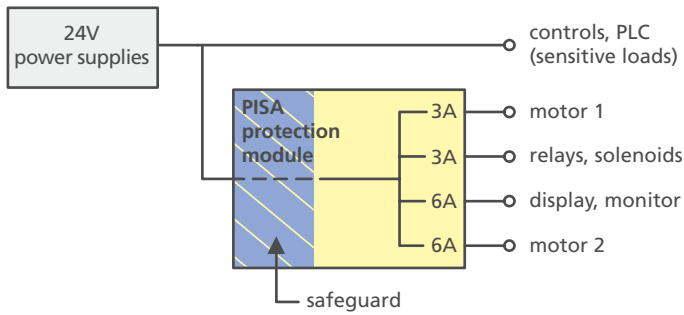

PISA11

Output Current	Channel 1 Channel 2 Channel 3 Channel 4	10A 10A 10A 10A	3A 3A 6A 6A	6A 6A 12A 12A	3.7A (NEC Class 2) 3.7A (NEC Class 2) 3.7A (NEC Class 2) 3.7A (NEC Class 2)
Nominal Voltage		DC24-28V	DC24-28V	DC24-28V	DC24-28V
Input Voltage Range		18-30Vdc	18-30Vdc	18-30Vdc	18-30Vdc
Required Input Voltage for Turning-On the Outputs, typ.		21.4Vdc	21.4Vdc	21.4Vdc	21.4Vdc
Turn-On Delay of Outputs		270ms	270ms	270ms	270ms
Input Voltage Protection Level min./max.		21.0Vdc/21.8Vdc	21.0Vdc/21.8Vdc	21.0Vdc/21.8Vdc	21.0Vdc/21.8Vdc
Output Current (All 4 Outputs)		20A	18A	20A	14.8A at 24V; 12.8A at 28V
Output Current Limitation min./max.		20.5A/30A	20.5A/30A	20.5A/30A	16.6A/23.6A
Shutdown-Times at Short Circuit, typ.		8ms	8ms	8ms	10ms
Voltage Drop, typ.		197mV	92mV (channel 1+2) 107mV (channel 3+4)	178mV (channel 1+2) 182mV (channel 3+4)	92mV at 24V, 81mV at 28V
Input Current at No Load, typ.		43mA	43mA	43mA	43mA
No-Load Losses, typ.		1.0W	1.0W	1.0W	1.0W
Power Losses, typ.		4.9W	1.9W	4.2W	1.6W
MTBF (+40°C, SN 29500)		1296 kh	2095 kh	1373 kh	2198 kh
Lifetime (min. at +40°C)		115 kh	213 kh	171 kh	220 kh
Operat. Temperature Range		-25°C to +70°C	-25°C to +70°C	-25°C to +70°C	-25°C to +70°C
Derating Each Channel		0.025A/°C	0.025A/°C	0.025A/°C	-
Dimensions WxHxD		45x75x91mm	45x75x91mm	45x75x91mm	45x75x91mm
Weight		120g	120g	120g	120g
Connection Terminals		screw	screw	screw	screw
Product Status		stock item	stock item	stock item	stock item
Product Family		DIMENSION	DIMENSION	DIMENSION	DIMENSION
Article number		PISA11.410	PISA11.203206	PISA11.206212	PISA11.CLASS2

# 24V DC-UPS with Batteries

For the installation of a DC-UPS system three essential elements are necessary: a power supply, a DC-UPS and a battery. The DC-UPS is responsible for monitoring and charging the battery, as well as controlling the seamless transition between normal and buffer mode.

The advantages of the PULS DC-UPS are:

- 1-Battery-Concept: Each battery is individually charged and monitored, which avoids the need for matched batteries
- Easy and self-explanatory plug-and-play usage
- Optimised battery management system for longest possible battery life
- 22.5-26V adjustable output voltage in buffer mode for the UB20
- Adjustable maximum buffer time to protect the battery



UB10 / UB20

Nominal Current	10A	10A	10A	20A	10A
Nominal Voltage	DC 24V	DC 24V	DC 24V	DC 24V	DC 24V
Storage Element	external battery	external battery	external battery	external battery	built-in battery
Allowed Battery Size	12V, 3.9 to 40Ah	12V, 17 to 130Ah	12V, 3.9 to 40Ah	24V, 3.9 to 150Ah	12V, 5Ah
Output 1 in Normal-mode	15A	15A	15A	25A	15A
Buffer-mode <sup>1)</sup>	10A/15A	10A/15A	10A/15A	20A/30A	10A/15A
Output 2 in Normal-mode	-	-	12V 5A	-	-
Buffer-mode	-	-	12V 5A	-	-
Output Power in Normal-mode	360W	360W	360W	600W	360W
Output Power in Buffer-mode <sup>1)</sup>	240W/360W	240W/360W	240W/360W	480W/720W	240W/360W
Output Voltage in Normal-mode	minimally smaller than input voltage				
Output Voltage in Buffer-mode	regulated to 22.5V	regulated to 22.5V	regulated to 22.5V and 12.0V	selectable: 22.5V/24V/25V/26V	regulated to 22.5V
Temperature Tracking of the End-of-Charge Voltage	manual select	manual select/ automatically	manual select	automatically with temp. sensor <sup>2)</sup>	automatically with temp. sensor
Int. Current Consumption (incl. Charging Current)	1.3A	2.2A	1.3A	2.1A/4.0A <sup>3)</sup>	1.3A
MTBF (+40°C, SN 29500)	886 kh	886 kh	788 kh	649 kh	886 kh
Min. Lifetime (+40°C)	137.4 kh	min. 137 kh	min. 114 kh	122 kh	min. 137 kh
Operat. Temperature Range	-25°C to +70°C	-25°C to +50°C	-25°C to +70°C	-40°C to +70°C	0°C to +40°C
Derating bei Pufferbetrieb	>60°C 0.25A/°C	-	>50°C 0.25A/°C	>60°C 0.5A/°C	-
Dimensions WxHxD	49x124x117mm	49x124x117mm	49x124x117mm	46x124x127mm	123x124x119mm
Weight	530g	545g	650g	750g	2.85kg
Connection Terminals	spring	spring	spring	screw	spring
Signals	ready, buffering, inhibit, replace battery				
Order Info	stock item	stock item	stock item	stock item	stock item
Product Family	DIMENSION	DIMENSION	DIMENSION	DIMENSION	DIMENSION
Article number	UB10.241	UB10.242	UB10.245	UB20.241	UBC10.241 UBC10.241-N1 <sup>4)</sup>

1) 15A/360W resp. 30A/720W for up to 5s 2) with PULS battery modules 3) if adjustable to <10Ah / >10Ah 4) battery not included

Battery modules use maintenance-free VRLA batteries (valve regulated lead-acid) and are fully charged at PULS before the delivery. Battery modules can be ordered with (UZK) or without a battery (UZO). All battery modules from PULS support the 1-Battery-Concept. The 24V battery modules are equipped with a center-tap, as well as an integrated temperature sensor and is thus protected against over-currents. Users who opt for using their own batteries and who still want to take advantage of the PULS-1-Battery-Concept, can use the sensor board with a PT1000 temperature sensor and center-tap fuse.

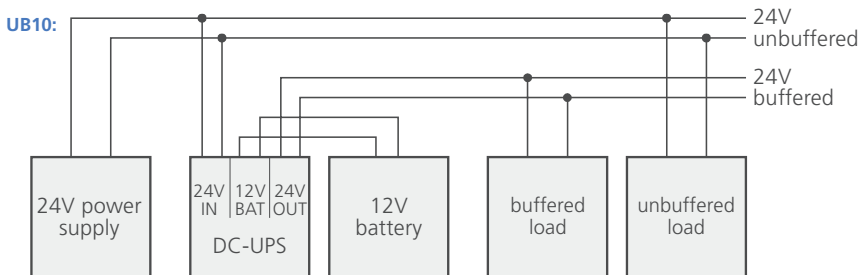

UZK12.071

Article number	Description	Dimensions
UZB12.051	12V, 5Ah battery replacement for UBC10.241	90x106x70mm
UZB12.071	12V, 7Ah battery replacement for UZK12.071, UZK12.072 und UZK24.071*	151x98x65mm
UZB12.121	12V, 12Ah battery replacement for UZK24.121*	151x98x98mm
UZB12.261	12V, 26Ah battery replacement for UZK12.261	175x125x166mm
UZK12.071	12V, 7Ah battery module for UB10	155x124x112mm
UZK12.072	12V, 7Ah battery module	158x132x98mm
UZK12.261	12V, 26Ah battery module for UB10	214x179x158mm
UZK24.071	24V, 7Ah battery module for UB20	137x186x143mm
UZK24.121	24V, 12Ah battery module for UB20	203x186x143mm
UZO12.07	same as UZK12.071, battery module but without battery	155x124x112mm
UZO12.072	same as UZK12.072, battery module but without battery	158x132x98mm
UZO12.26	same as UZK12.261, battery module but without battery	214x179x158mm
UZO24.071	same as UZK24.071, battery module but without battery	137x186x143mm
UZO24.121	same as UZK24.121, battery module but without battery	203x186x143mm
UZS24.100	sensorboard with PT1000 temperature sensor and center-tap fuse	23x15x110.5mm

\* Two required

# Buffer Times

Buffer current	0.5A	1A	3A	5A	7A	10A	15A	20A
<b>UBC10.241</b>	3h 50min	2h	30min	16min	11min	6min	5s	-
<b>UB10 + 7Ah Battery (12V)</b>	5h 10min	2h 30 min	38min	20min	13min	6min	5s	-
<b>UB10 + 12Ah Battery (12V)</b>	10h 41min	5h 17min	1h 40min	46min	28min	16min	5s	-
<b>UB10 + 26Ah Battery (12V)</b>	23h 6min	11h 23min	3h 40min	2h 10min	1h 30min	55min	5s	-
<b>UB10 + 65Ah Battery (12V)</b>	2d 11h	1d 5h	9h 53min	5h 51min	4h	2h 45min	5s	-
<b>UB10 + 100Ah Battery (12V)</b>	3d 19h	1d 21h	14h 53min	8h 41min	6h	4h 7min	5s	-
<b>UB10 + 130Ah Battery (12V)</b>	4d 23h	2d 11h	19h 21 min	11h 18min	7h 48min	5h 21min	5s	-
<b>UB20 + 7Ah Battery (24V)</b>	9h 26min	5h 16min	1h 30min	46min	30min	19min	10min	6min
<b>UB20 + 12Ah Battery (24V)</b>	17h 13min	9h 51min	3h 29min	2h 02min	1h 23min	46min	27min	16min
<b>UB20 + 26Ah Battery (24V)</b>	1d 13h	21h 34min	7h 32min	4h 26min	3h 7min	2h 10min	1h 17min	55min
<b>UB20 + 65Ah Battery (24V)</b>	3d 19h	2d 4h	20h 5min	11h 56min	8h 25min	5h 50min	3h 49min	2h 49min
<b>UB20 + 100Ah Battery (24V)</b>	6d 3h	3d 11h	1d 6h	18h 30min	13h 10min	9h 11min	6h 3min	4h 31min
<b>UB20 + 140Ah Battery (24V)</b>	8d 12h	4d 21h	1d 19h	1d 1h	18h 26min	12h 52min	8h 27min	6h 19min

## UB10

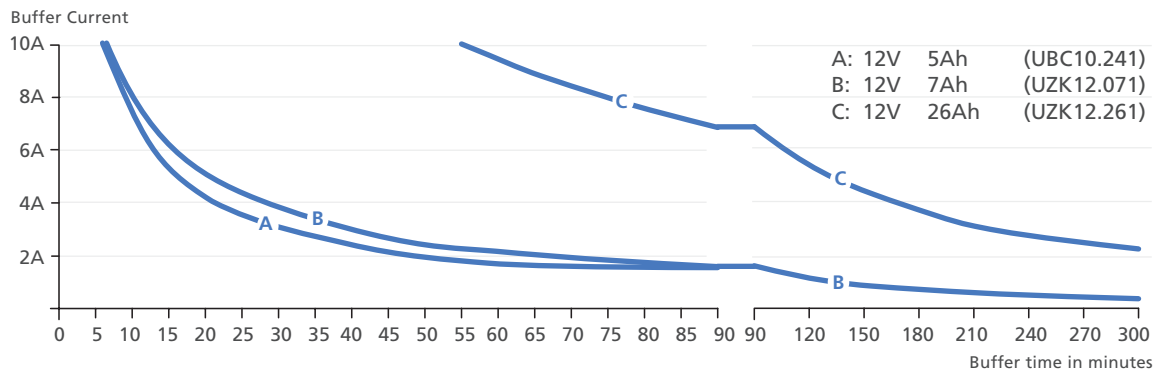

## UB20

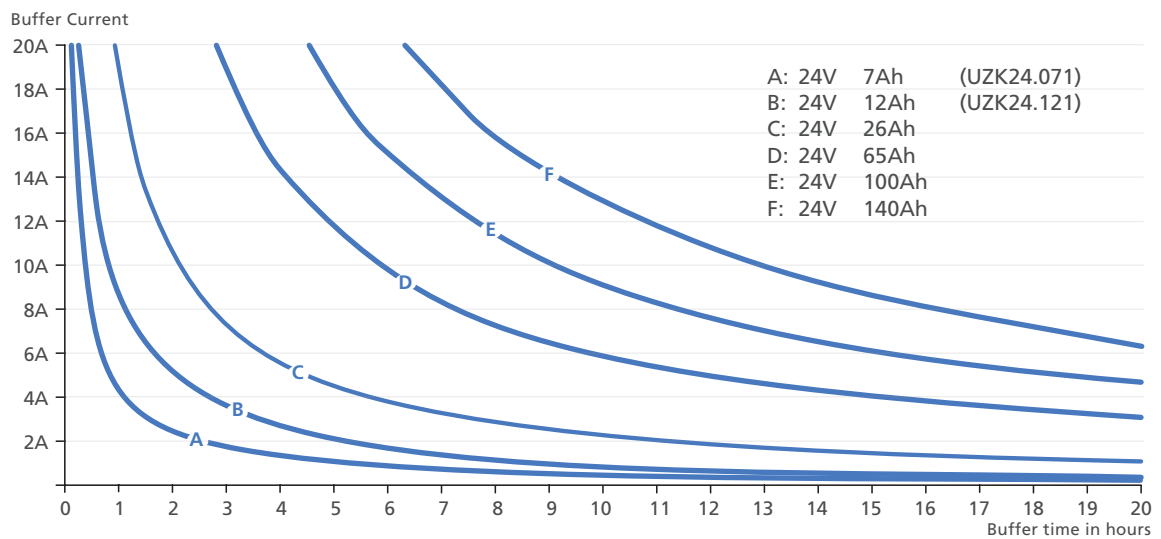

The table above shows typical buffer times of standard battery modules. The aging effect during operation is not included. We recommend to expect a buffer time reduction of 30-50% for the life of the batteries.

# Buffer Modules / DC-UPS with Capacitor Storage

DC-UPS,  
Buffer Modules

The DC-UPS with integrated electrochemical double layer capacitors are fully maintenance free and guarantee an uninterrupted power supply for periods measured in seconds. Buffer modules with electrolytic capacitors work similarly to a DC-UPS and can bridge power failures in the 24V or 48V net for periods measured in milliseconds (see graphs below).

In contrary to the DC-UPS systems where the replacement of batteries is required based on batteries, a regular replacement of the capacitors is not necessary. In buffer mode, the output voltage is regulated and the change from normal to buffer mode occurs without interruptions. All modules are protected against overload as well as short-circuit and have a wide operating temperature range.



Nominal Voltage	DC 24V		DC 24V	DC 24V	DC 48V
Storage Element	Electrochemical Double Layer Capacitors		Electrolytic Capacitors		
Integrated Storage Element	6 kW <sub>s</sub>	12 kW <sub>s</sub>	0.2 kW <sub>s</sub>	0.32 kW <sub>s</sub>	0.2 kW <sub>s</sub>
Nominal Current	15A	15A	not relevant		
Buffer Current, max.	15A	15A	20A	40A	20A
Voltage in Buffer-mode	22.5V	22.5V	22.5V *	22.5V *	45V *
Separation of Input and Output	yes	yes	no	no	no
Charging Time	16 minutes	32 minutes	18 seconds	34 seconds	22 seconds
Buffer Time	typ. 16.5s at 10A typ. 9s at 15A	typ. 33s at 10A typ. 18s at 15A	310ms at 20A	250ms at 40A 500ms at 20A	150ms at 20A
Power Losses, typ.	4.6W at 10A		1.9W in stand-by	1.9W in stand-by	1.9W in stand-by
MTBF (+40°C, SN 29500)	854 kh	850 kh	2327 kh	2114 kh	2348 kh
Lifetime (min. at +40°C)	96 kh	96 kh	166 kh **	189 kh **	161 kh **
Operat. Temperature Range	-40°C to +60°C		-25°C to +70°C		
Connection Terminals	spring	spring	spring	screwn	spring
Dimensions WxHxD	126x124x117mm	198x124x117mm	64x124x102mm	64x124x142mm	64x124x102mm
Weight	1150g	1720g	740g	1040g	740g
Signals	ready, buffering, inhibit, PC-mode		ready, buffering, inhibit		
Product Status	stock item	stock item	stock item	stock item	stock item
Product Family	DIMENSION	DIMENSION	DIMENSION	DIMENSION	DIMENSION
Article number	UC10.241	UC10.242	UF20.241	UF40.241	UF20.481

\* Or selectable 1V (UF20.241) or 2V (UF20.481) smaller than input voltage \*\* In stand-by mode

# Buffer Times

Buffer current	0.5A	1A	3A	5A	7A	10A	15A	20A	30A	40A
UF20.481	6.4s	3.2s	1s	660ms	470ms	300ms	220ms	150ms	-	-
UF20.241	12.7s	6.5s	2.2s	1.3s	950ms	670ms	450ms	310ms	-	-
UF40.241	20s	10.6s	3.6s	2.1s	1.5s	1s	730ms	500ms	350ms	250ms
UC10.241	340s	200s	68s	39s	26s	16.5s	9s	-	-	-
UC10.242	680s	400s	136s	78s	53s	33s	18s	-	-	-

Buffer time with electrochemical double layer capacitors:

Buffer time with electrolytic capacitors:

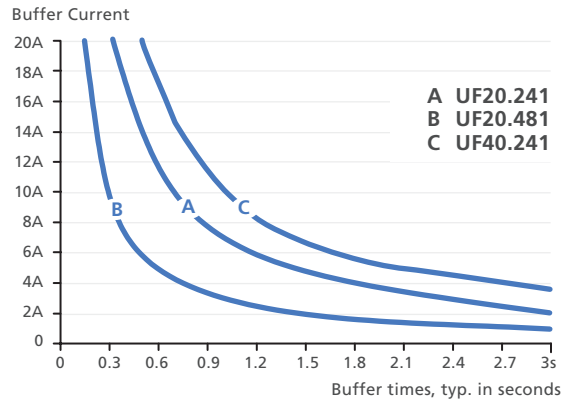
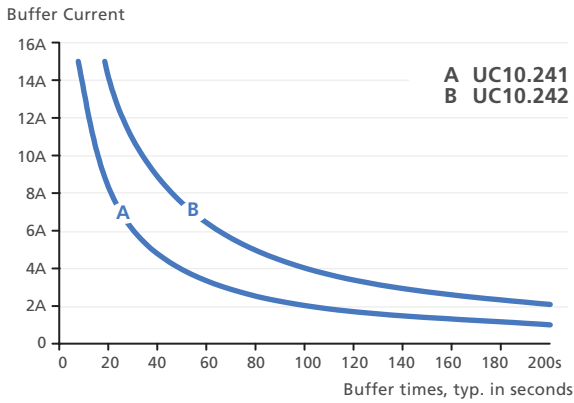

# Mounting Brackets

Mounting brackets for direct wall or panel mounting without the need for DIN rail. Other brackets can be used for sideways installation of the power supplies with or without DIN rail for control cabinets which do not have the required installation depth.



ZM1.WALL

ZM1.UBC10

ZM5.WALL

ZM11.SIDE

ZM10.WALL

Article number	Wall mounting bracket
ZM1.WALL	for various light DIMENSION units
ZM2.WALL	for QS20, QS40, QT40, CPS20, ...
ZM3.WALL	for ML60, PISA11 and MLY (PU 25 pieces)
ZM10.WALL	for various DIMENSION units
ZM1.UBC10	for UBC10

Article number	Side mounting bracket
ZM11.SIDE	CS3, CS5, QS3, YR2, YRM2
ZM12.SIDE	CT5, QS5
ZM13.SIDE	CS10, CT10, QS10, CPS20, ...
ZM14.SIDE	QT20, QTD20, UF20
ZM15.SIDE	QS20 (except QS20.244)

Service

# PULS product details for CAE-software



The EPLAN data portal contains data from more than 910,000 products from 282 manufacturers.



all PULS products at EPLAN



The WSCAD universe contains data from more than 1.4 million products from 280 manufacturers.



all PULS products at WSCAD



PULS provides extensive data packages for DIN rail power supplies and supplementary devices of the product families DIMENSION, PIANO and MiniLine.

This enables system developers to easily import the standardized device data directly into the common CAE software solutions developed by EPLAN or WSCAD.

Hence, with this optimized device data, PULS offers great added value in project planning. The consistently high level of detail contained in the DIN rail power supply data thus facilitates the digital planning and implementation of complex development projects.

All PULS products can directly be taken over into the bill of materials.

## International

The original product database at PULS is available in 6 different languages as well as free of charge. This data can be found on both the EPLAN Data Portal and WSCAD Universe portals.

## Precise

PULS creates realistic 3D macros, connection diagrams, exact assembly views and high-resolution product images.

## Innovative

PULS represents one of the first manufacturers to support the new EPLAN data standard making use of consistent and standardized component data.

### TIPP

*You will find the EPLAN and WSCAD logo on the product detail pages of our website below the product images.*

*Clicking on the logo will take you directly to the PULS device data on the EPLAN data portal and WSCAD universe. You can also download the EDZ files directly from the „Downloads“ section of each product.*

# PULS Power House

The Single Source for Power Solutions



## PULS

### Standard Products

- 1-phase and 3-phase power supplies
- Broad range of additional DC UPS, redundancy, protection and buffer modules

## PULS Vario

### Customised Solutions

- Value-add solutions
- Modifications
- Complete power solutions



# Value-add solutions

## Innovative modular system

The value-add systems are based on an 80/20 principle. This means that for the implementation of a value-add project, about 80% original or modified standard power supplies and only 20% purely customer-specific assemblies are used.

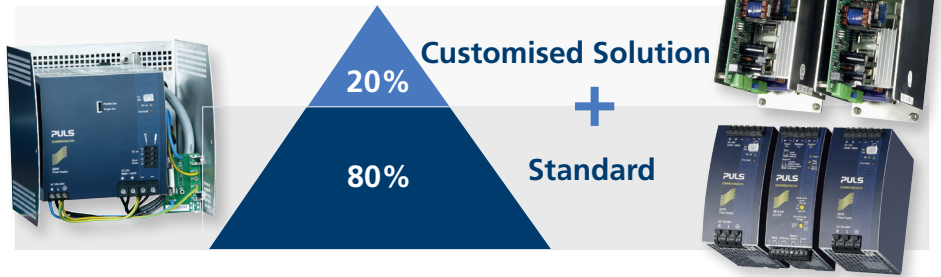

Special housing protects against dripping water with switch and plug connector

Uninterruptable DC/DC-converter with two output voltages



## Power supply system for SMT placement machine

The value-add system for this application includes three standard power supplies, two modified power supplies and a customised buffer module. The system is optimised for powering dynamic loads and covers the high peak loads of up to 30kW with the energy from the buffer module, which avoids undesirable effects on the grid.

# Modifications

## AC/DC-converter for fire protection systems

- Input: AC 100-240V
- Output: 36Vdc
- Power: 240W
- Parallel mode for load sharing
- Decoupling module at output

## Power supply with two output voltages and fan

- Input: 3AC 400-480V
- Output: 162Vdc and 300Vdc
- Optimised for dynamic loads
- High lifetime expectation at +60°C ambient temperature
- Communication interface

## DC/DC-converter for solar applications

- Input: DC 240-460V
- Output: 24Vdc
- Power: 480W



# Complete power solutions

PULS always tries to generate a cost-efficient solution based on its proven standard products. Nevertheless, customer-specific power supplies or modules can be necessary to complement a Value-Add system or to match the special requirements of a customer. If you are interested in a customised and complete power solution, please contact our support team.

# Standards and Approvals

	page	CE	UL 508	UL 60950-1	UL 61010-2-201	IEC 60950-1 CB-Scheme	IEC 61010-2-201 CB-Scheme	IECEX	ATEX	Class I Div. 2 HazLoc	DNV Marine	ABS Marine	EAC Registration	NEC Class 2	EN 50155 Railway	IEC 60601-1, edition, Medical	EN 61000-3-2 Harmonics (PFC)	EN 61000-6-1 Immunity for residential environments	EN 61000-6-2 Immunity for industrial environments	EN 61000-6-3 Emission for residential environments	EN 61000-6-4 Emission for industrial environments	EN 55011 / EN 55022 class B Disturbance characteristics
<b>Power Supplies</b>																						
CD5.121	30	•	•	•		•		•	•	•	•	•	•				5	•	•	•	•	•
CD5.241	30	•	•	•	•	•	•	•	•	•	•	•	•				5	•	•	•	•	•
CD5.241-L1	30	•	•	•	•	•	•	•	•	•	•	•	•	•			5	•	•	•	•	•
CD5.241-S1	30	•	•	•	•	•	•	•	•	•	•	•	•				5	•	•	•	•	•
CD5.242	31	•	•	•		•		•	•	•	•	•	•				5	•	•	•	•	•
CD5.243	30	•	•	•		•		•	•	•	•	•	•				5	•	•	•	•	•
CD10.241	31	•			•	•	(•)	(•)	(•)				•				5	•	•	•	•	•
CD10.242	31	(•)											•				5	•	•	•	•	•
CD10.482	31	•			•	•	(•)	(•)	•				•				5	•	•	•	•	•
CP5.121	19	•			•		•	•	•	•			•				2	•	•	•	•	•
CP5.241	22	•			•		•	•	•	•			•				2	•	•	•	•	•
CP5.241-C1	22	•			•		•	•	•	•			•				2	•	•	•	•	•
CP5.241-S1	22	•			•		•	•	•	•			•				2	•	•	•	•	•
CP5.241-S2	22	•			•		•	•	•	•			•				2	•	•	•	•	•
CP5.242	22	•			•		•						•				2	•	•	•	•	•
CP5.481	26	•			•	•	•	•	•	•			•				2	•	•	•	•	•
CP10.121	19	•	•	•		•		•	•	•	•	•	•				2	•	•	•	•	•
CP10.122	19	•	•	(•)		(•)							•				2	•	•	•	•	•
CP10.241	23	•	•	•		•		•	•	•	•	•	•				2	•	•	•	•	•
CP10.241-60	32	•											•		•		5	•	•	•	•	•
CP10.241-C1	23	•	•	•		•		•	•	•	•	•	•				2	•	•	•	•	•
CP10.241-M1	33	•			•		•				(•)		•		•		2	•	•	•	•	•
CP10.241-R1	37	•			•	•	•	•	•	•			•				2	•	•	•	•	•
CP10.241-R2	37	•			•		•	•	•	•			•				2	•	•	•	•	•
CP10.241-R2-C1	37	•			•	•	•	•	•	•			•				2	•	•	•	•	•
CP10.241-S1	23	•	•	•		•		•	•	•	•	•	•				2	•	•	•	•	•
CP10.241-S2	23	•	(•)	(•)	•	•	•	•	•				•				2	•	•	•	•	•
CP10.242	23	•	•	•		•		•	•	•	•	•	•				2	•	•	•	•	•
CP10.242-R2	37	•		(•)	•	•	•	(•)		•			•				2	•	•	•	•	•
CP10.361	25	•	•	•		•		•	•	•	•	•	•				2	•	•	•	•	•
CP10.481	27	•	•	•		•		•	•	•	•	•	•				2	•	•	•	•	•
CP20.241	24	•			•		•	•	•	•			•				2	•	•	•	•	•
CP20.241-C1	24	•			•		•	•	•	•			•				2	•	•	•	•	•
CP20.241-R1	37	•			•		•	•	•	•			•				2	•	•	•	•	•
CP20.241-R2	37	•			•		•	•	•	•			•				2	•	•	•	•	•
CP20.241-R2-C1	37	•			•		•	•	•	•			•				2	•	•	•	•	•

- fulfilled
- (•) in preparation
- not fulfilled

- 1) meets class A limits (passive)
- 2) meets class A limits (active)
- 3) not applicable (<75VA)
- 4) not applicable (<220Vac)
- 5) not applicable for this type of unit

	page	CE	UL 508	UL 60950-1	UL 61010-2-201	IEC 60950-1 CB-Scheme	IEC 61010-2-201 CB-Scheme	IECEX	ATEX	Class I Div. 2 HazLoc	DNV Marine	ABS Marine	EAC Registration	NEC Class 2	EN 50155 Railway	IEC 60601-1, edition, Medical	EN 61000-3-2 Harmonics (PFC)	EN 61000-6-1 Immunity for residential environments	EN 61000-6-2 Immunity for industrial environments	EN 61000-6-3 Emission for residential environments	EN 61000-6-4 Emission for industrial environments	EN 55011 / EN 55022 class B Disturbance characteristics
CP20.241-S1	24	•			•	•	•	•	•	•			•				2	•	•	•	•	•
CP20.241-S2	24	•			•	•	•	•	•	•			•				2	•	•	•	•	•
CP20.241-V1	24	•			•	•	•	•	•	•			•				2	•	•	•	•	•
CP20.242	24	•			•		•						•				2	•	•	•	•	•
CP20.242-R2	37	•			•		•	(•)	(•)				•				2	•	•	•	•	•
CP20.245-R2	33	•			•		•	•	•		•	•					2	•	•	•	•	•
CP20.481	27	•			•		•	•	•	•			•				2	•	•	•	•	•
CPS20.121	19	•	•	•		•		•	•	•	•	•	•				2	•	•	•	•	•
CPS20.241	24	•	•	•		•		•	•	•	•	•	•				2	•	•	•	•	•
CPS20.241-60	32	•											•		•		5		•		•	
CPS20.241-C1	24	•	•	•		•		•	•	•	•	•	•		•		2	•	•	•	•	•
CPS20.241-D1	24	•	•	•		•		•	•	•	•	•	•				5	•	•	•	•	•
CPS20.361	25	•	•	•		•		•	•	•	•	•	•				2	•	•	•	•	•
CPS20.481	27	•	•	•		•		•	•	•	•	•	•				2	•	•	•	•	•
CPS20.481-D1	27	•	•	•		•		•	•	•			•				5	•	•	•	•	•
CS3.241	21	•	•	•		•				•	•	•	•	•			1	•	•	•	•	•
CS5.241	22	•	•	•		•				•	•	•	•				-	•	•		•	•
CS5.241-C1	22	•	•	•		•				•	•	•	•				-	•	•		•	•
CS5.241-S1	22	•	•	•		•				•	•	•	•				-	•	•		•	•
CS5.243	22	•	•	•		•				•	•	•	•				4	•	•	•	•	•
CS5.244	22	•	•	•		•				•	•	•	•				1	•	•	•	•	•
CS10.241	23	•	•	•		•				•	•	•	•				-	•	•		•	•
CS10.241-S1	23	•	•	•		•				•	•	•	•				-	•	•		•	•
CS10.242	23	•	•	•		•				•	•	•	•				1	•	•	•	•	•
CS10.243	23	•	•	•		•				•	•	•	•				4	•	•	•	•	•
CS10.244	23	•	•	•		•				•	•	•	•				-	•	•		•	•
CS10.481	26	•	•	•		•				•	•	•	•				-	•	•		•	•
CT5.121	28	•	•	•		•				•	•	•	•				1	•	•	•	•	•
CT5.241	28	•	•	•		•				•	•	•	•				1	•	•	•	•	•
CT10.241	28	•	•	•		•				•	•	•	•				1	•	•	•	•	•
CT10.241-C1	28	•	•	•		•				•	•	•	•				1	•	•	•	•	•
CT10.481	29	•	•	•		•				•	•	•	•				1	•	•	•	•	•

- fulfilled
- (•) in preparation
- not fulfilled

- 1) meets class A limits (passive)
- 2) meets class A limits (active)
- 3) not applicable (<75VA)
- 4) not applicable (<220Vac)
- 5) not applicable for this type of unit

# Standards and Approvals

	page	CE	UL 508	UL 60950-1	UL 61010-2-201	IEC 60950-1 CB-Scheme	IEC 61010-2-201 CB-Scheme	IECEX	ATEX	Class I Div. 2 HazLoc	DNV Marine	ABS Marine	EAC Registration	NEC Class 2	EN 50155 Railway	IEC 60601-1, edition, Medical	EN 61000-3-2 Harmonics (PFC)	EN 61000-6-1 Immunity for residential environments	EN 61000-6-2 Immunity for industrial environments	EN 61000-6-3 Emission for residential environments	EN 61000-6-4 Emission for industrial environments	EN 55011 / EN 55022 class B Disturbance characteristics
ML15.051	18	•	•	•		•				•	•	•	•	•			3	•	•	•	•	•
ML15.121	18	•	•	•		•				•	•	•	•	•			3	•	•	•	•	•
ML15.241	20	•	•	•		•				•	•	•	•	•			3	•	•	•	•	•
ML30.100	20	•	•	•		•				•	•	•	•	•			3	•	•	•	•	•
ML30.101	18	•	•	•		•				•			•	•			3	•	•	•	•	•
ML30.102	18	•	•	•		•					•	•	•	•			3	•	•	•	•	•
ML30.106	19	•	•	•		•				•	•	•	•	•			3	•	•	•	•	•
ML30.241	20	•	•	•		•				•	•	•	•	•			3	•	•	•	•	•
ML50.100	20	•	•	•		•				•			•	•			3	•	•	•	•	•
ML50.101	20	•	•	•		•				•			•	•			3	•	•	•	•	•
ML50.102	18	•	•	•		•							•	•			3	•	•	•	•	•
ML50.105	26	•	•	•		•				•	•	•	•	•			3	•	•	•	•	•
ML50.109	20	•	•	•		•				•	•	•	•	•			3	•	•	•	•	•
ML50.111	20	•	•	•		•				•	•	•	•	•			3	•	•	•	•	•
ML60.121	18	•	•	•		•				•	•	•	•	•			3	•	•	•	•	•
ML60.122	19	•	•	•		•				•	•	•	•	•			3	•	•	•	•	•
ML60.241	21	•	•	•		•				•	•	•	•	•			3	•	•	•	•	•
ML60.242	21	•	•	•		•				•	•	•	•	•			1	•	•	•	•	•
ML70.100	21	•	•	•		•					•	•	•	•			1	•	•	•	•	•
ML90.200	28	•	•	•		•				•			•	•			1	•	•	•	•	•
ML95.100	22	•	•	•		•	•			•	•	•	•				1	•	•	•	•	•
ML100.100	22	•	•	•		•	•			•	•	•	•				1	•	•	•	•	•
ML100.102	19	•	•	•		•					•	•	•				1	•	•	•	•	•
ML100.105	26	•	•	•		•					•	•	•				1	•	•	•	•	•
ML100.109	22	•	•	•		•	•			•			•				1	•	•	•	•	•
ML100.200	28	•	•	•		•					•	•	•				1	•	•	•	•	•
PIC120.241C	22	•			•		•						•				1	•	•	•	•	•
PIC120.241D	23	•			•		•				•	•	•				1	•	•	•	•	•
PIC120.242C	22	•			•		•				•	•	•				-	•	•		•	•
PIC240.241C	24	•			•		•						•				2	•	•	•	•	•
PIC240.241D	24	•			•	•	•						•				2	•	•	•	•	•
PIC480.241C	24	•			•		•						•				2	•	•	•	•	•
PIC480.241C-C1	24	•			•		•						•				2	•	•	•	•	•
PIC480.241D	25	•			•		•						•				2	•	•	•	•	•
PIC480.481D	27	•			•		•										3	•	•	•	•	•
PIM36.241	20	•			•		•							•								
PIM60.121	19	•			•		•						•	•								

- fulfilled
- (•) in preparation
- not fulfilled

- 1) meets class A limits (passive)
- 2) meets class A limits (active)
- 3) not applicable (<75VA)
- 4) not applicable (<220Vac)
- 5) not applicable for this type of unit

	page	CE	UL 508	UL 60950-1	UL 61010-2-201	IEC 60950-1 CB-Scheme	IEC 61010-2-201 CB-Scheme	IECEX	ATEX	Class I Div. 2 HazLoc	DNV Marine	ABS Marine	EAC Registration	NEC Class 2	EN 50155 Railway	IEC 60601-1, edition, Medical	EN 61000-3-2 Harmonics (PFC)	EN 61000-6-1 Immunity for residential environments	EN 61000-6-2 Immunity for industrial environments	EN 61000-6-3 Emission for residential environments	EN 61000-6-4 Emission for industrial environments	EN 55011 / EN 55022 class B Disturbance characteristics
PIM60.125	19	•			•		•							•			3	•	•	•	•	•
PIM60.241	21	•			•		•						•	•			3	•	•	•	•	•
PIM60.245	21	•			•		•						•	•			3	•	•	•	•	•
PIM90.241	21	•			•	(•)	•						•				1	•	•	•	•	•
PIM90.245	21	•			•	(•)	•						•				1	•	•	•	•	•
PIM90.245-L1	21	•			•		•							•			1	•	•	•	•	•
PIRD20.241	38	•	•	•		•		•	•	•			•				5	•	•	•	•	•
POE.4AT-DC1	35	•	•	•	(•)	•	(•)	•	•	•			•									
POE.8AT-DC1	35	•			(•)												5	•	•	•	•	•
POE.4AT-AC1	35	•																				
POE.8AT-AC1	35	•			(•)												2	•	•	•	•	•
QS3.241	21	•	•	•		•	•			•	•	•	•				2	•	•	•	•	•
QS5.241	23	•	•	•		•				•	•	•	•				2	•	•	•	•	•
QS5.241-60	32	•											•		•		5	•	•	•	•	•
QS5.241-A1	23	•	•	•		•	(•)	•	•	•	•	•	•				2	•	•	•	•	•
QS5.DNET	21	•	•	•		•				•	•	•	•	•			2	•	•	•	•	•
QS10.121	19	•	•	•		•	•			•	•	•	•				2	•	•	•	•	•
QS10.241	24	•	•	•		•	•			•	•	•	•				2	•	•	•	•	•
QS10.241-60	32	•					•						•		•		5	•	•	•	•	•
QS10.241-A1	24	•	•	•		•	•	•	•	•	•	•	•				2	•	•	•	•	•
QS10.241-C1	24	•	•	•		•	•			•	•	•	•		•		2	•	•	•	•	•
QS10.241-D1	24	•	•	•		•	•						•				2	•	•	•	•	•
QS10.301	25	•	•	•		•	•			•	•	•	•				2	•	•	•	•	•
QS10.481	27	•	•	•		•	•			•	•	•	•				2	•	•	•	•	•
QS10.481-D1	27	•	•	•		•	•						•				2	•	•	•	•	•
QS10.DNET	23	•	•	•		•	•			•	•	•	•				2	•	•	•	•	•
QS20.241	25	•	•	•		•				•	•	•	•				2	•	•	•	•	•
QS20.241-A1	25	•	•	•		•		•	•	•	•	•	•				2	•	•	•	•	•
QS20.241-C1	25	•	•	•		•				•	•	•	•				2	•	•	•	•	•
QS20.244	25	•	•	•		•				•	•	•	•				-	•	•	-	•	•
QS20.361	25	•	•	•		•				•	•	•	•				2	•	•	•	•	•
QS20.481	27	•	•	•		•				•	•	•	•				2	•	•	•	•	•
QS40.241	25	•	•	•		•		•	•	•	•	•	•				2	•	•	•	•	•
QS40.244	25	•	•	•		•					•	•	•				2	•	•	•	•	•
QS40.361	26	•	•	•		•		•	•	•	•	•	•				2	•	•	•	•	•
QS40.481	27	•	•	•		•		•	•	•	•	•	•				2	•	•	•	•	•
QS40.484	27	•	•	•		•					•	•	•				2	•	•	•	•	•

- fulfilled
- (•) in preparation
- not fulfilled

- 1) meets class A limits (passive)
- 2) meets class A limits (active)
- 3) not applicable (<75VA)
- 4) not applicable (<220Vac)
- 5) not applicable for this type of unit

# Standards and Approvals

	page	CE	UL 508	UL 60950-1	UL 61010-2-201	IEC 60950-1 CB-Scheme	IEC 61010-2-201 CB-Scheme	IECEX	ATEX	Class I Div. 2 HazLoc	DNV Marine	ABS Marine	EAC Registration	NEC Class 2	EN 50155 Railway	IEC 60601-1, edition, Medical	EN 61000-3-2 Harmonics (PFC)	EN 61000-6-1 Immunity for residential environments	EN 61000-6-2 Immunity for industrial environments	EN 61000-6-3 Emission for residential environments	EN 61000-6-4 Emission for industrial environments	EN 55011 / EN 55022 class B Disturbance characteristics
QT20.241	28	•	•	•		•				•	•	•	•				1	•	•	•	•	•
QT20.241-C1	28	•	•	•		•				•	•	•	•		•		1	•	•	•	•	•
QT20.361	29	•	•	•		•				•	•	•	•				1	•	•	•	•	•
QT20.481	29	•	•	•		•				•	•	•	•				1	•	•	•	•	•
QT40.241	28	•	•	•		•					•	•	•				2	•	•	•	•	•
QT40.241-B2	9	•			(•)								•				2		•		•	•
QT40.242	28	•	•	•		•							•				2	•	•	•	•	•
QT40.361	29	•	•	•		•							•				2	•	•	•	•	•
QT40.481	29	•	•	•		•					•	•	•				2	•	•	•	•	•
QTD20.241	31	•	•				•						•				5	•	•			•
XT40.241	29	•	•	•		•							•				1	•	•	•	•	•
XT40.242	29	•	•	•		•							•				1	•	•	•	•	•
XT40.361	29	•	•	•		•							•				1	•	•	•	•	•
XT40.362	29	•	•	•		•							•				1	•	•	•	•	•
XT40.481	29	•	•	•		•							•				1	•	•	•	•	•
XT40.482	29	•	•	•		•							•				1	•	•	•	•	•
XT40.721	29	•	•	•		•							•				1	•	•	•	•	•
XT40.722	29	•	•	•		•							•				1	•	•	•	•	•
<b>Supplementars units</b>																						
MLY02.100	38	•	•	•		•		•	•	•	•	•	•				5	•	•	•	•	•
MLY10.241	38	•	•	•		•		•	•	•	•	•	•				5	•	•	•	•	•
PISA11.203206	41	•	•	•		•			•	•	•	•	•				5	•	•	•	•	•
PISA11.206212	41	•	•	•		•				•	•	•	•				5	•	•	•	•	•
PISA11.401	40	•	•	•		•				•	•	•	•	•			5	•	•	•	•	•
PISA11.402	40	•	•	•		•				•	•	•	•	•			5	•	•	•	•	•
PISA11.403	40	•	•	•		•				•	•	•	•	•			5	•	•	•	•	•
PISA11.404	40	•	•	•		•				•	•	•	•	•			5	•	•	•	•	•
PISA11.406	40	•	•	•		•				•	•	•	•	•			5	•	•	•	•	•
PISA11.410	41	•	•	•		•				•	•	•	•	•			5	•	•	•	•	•
PISA11.CLASS2	41	•	•	•		•				•	•	•	•	•			5	•	•	•	•	•
SLD2.100		•											•				5	•	•	•	•	•
UB10.241	42	•	•	•		•		•	•	•	•	•	•				5	•	•	•	•	•
UB10.242	42	•	•	•		•		•	•	•	•	•	•				5	•	•	•	•	•
UB10.245	42	•	•	•		•		•	•	•	•	•	•				5	•	•	•	•	•
UB20.241	42	•	•	•		•		•	•	•	•	•	•				5	•	•	•	•	•
UBC10.241	42	•	•	•		•		•	•	•	•	•	•				5	•	•	•	•	•
UBC10.241-N1	42	•	•	•		•		•	•	•	•	•	•				5	•	•	•	•	•

- fulfilled
- (•) in preparation
- not fulfilled

- 1) meets class A limits (passive)
- 2) meets class A limits (active)
- 3) not applicable (<75VA)
- 4) not applicable (<220Vac)
- 5) not applicable for this type of unit

	page	CE	UL 508	UL 60950-1	UL 61010-2-201	IEC 60950-1 CB-Scheme	IEC 61010-2-201 CB-Scheme	IECEX	ATEX	Class I Div. 2 HazLoc	DNV Marine	ABS Marine	EAC Registration	NEC Class 2	EN 50155 Railway	IEC 60601-1, edition, Medical	EN 61000-3-2 Harmonics (PFC)	EN 61000-6-1 Immunity for residential environments	EN 61000-6-2 Immunity for industrial environments	EN 61000-6-3 Emission for residential environments	EN 61000-6-4 Emission for industrial environments	EN 55011 / EN 55022 class B Disturbance characteristics
UC10.241	45	•	•	•		•		•	•	•			•				5	•	•	•	•	•
UC10.242	45	•	•	•		•		•	•	•			•				5	•	•	•	•	•
UF20.241	45	•	•	•		•							•				5	•	•	•	•	•
UF20.481	45	•	•	•		•							•				5	•	•	•	•	•
UF40.241	45	•	•	•	•	•	•						•				5	•	•	•	•	•
UZB12.051	43												•				5					
UZB12.071	43												•				5					
UZB12.121	43												•				5					
UZB12.261	43												•				5					
UZK12.071	43	•			(•)			•	•	•	•	•	•				5	•	•	•	•	•
UZK12.072	43	•	(•)		•	•		•	•	(•)	(•)		•				5	•	•	•	•	•
UZK12.261	43	•	(•)		•	•		•	•	•	•	•	•				5	•	•	•	•	•
UZK24.071	43	•			•	•		•	•	•			•				5	•	•	•	•	•
UZK24.121	43	•			•	•		•	•	•			•				5	•	•	•	•	•
UZO12.07	43	•			(•)			•	•	•	•	•	•				5	•	•	•	•	•
UZO12.072	43	•	(•)		•	•		•	•	(•)	(•)		•				5	•	•	•	•	•
UZO12.26	43	•	(•)		•	•		•	•	•	•	•	•				5	•	•	•	•	•
UZO24.071	43	•			•	•		•	•	•			•				5	•	•	•	•	•
UZO24.121	43	•			•	•		•	•	•			•				5	•	•	•	•	•
UZS24.100	43	•			•	•				•			•				5	•	•	•	•	•
YR2.DIODE	38	•	•	•		•		•	•	•	•	•	•				5	•	•	•	•	•
YR20.242	39	•	•	•		•		•	•	•			•				5	•	•	•	•	•
YR20.246	39	•	•	•		•		•	•	•	•	•	•				5	•	•	•	•	•
YR40.241	39	•	•	•		•		•	•	•	•	•	•				5	•	•	•	•	•
YR40.242	39	•	•	•		•		•	•	•	•	•	•				5	•	•	•	•	•
YR40.245	39	•	•	•		•		•	•	•	•	•	•				5	•	•	•	•	•
YR40.482	39	•	•	•		•		•	•	•	•	•	•				5	•	•	•	•	•
YR80.241	39	•	•	•		•		•	•	•	•	•	•				5	•	•	•	•	•
YR80.242	39	•	•	•		•		•	•	•	•	•	•				5	•	•	•	•	•
YRM2.DIODE	38	•	•	•		•		•	•	•	•	•	•				5	•	•	•	•	•

- fulfilled
- (•) in preparation
- not fulfilled

- 1) meets class A limits (passive)
- 2) meets class A limits (active)
- 3) not applicable (<75VA)
- 4) not applicable (<220Vac)
- 5) not applicable for this type of unit

# Standards and Approvals

## Available Standards and Approvals – An Overview of PULS Products:



Europa

**CE mark:** The CE mark in relation with the manufacturer's Declaration of Conformity confirms that the directives of the European Union stated in the manufacturer's declaration of conformity have been fulfilled. European standards (EN standards) provide the foundation for fulfilling the directives.



USA, Canada

Depending on the target application the approval process (certification mark) can run under two different standards.

**Industrial Control Equipment (ICE):** Instrumentation for control devices. The test standard is based on **UL 508**.



**Safety requirements for electrical equipment for measurement, control, and laboratory use – part 1 & 2:** The test standards are based on **UL 61010-1** and **UL 61010-2-201**.

The certification mark is issued by the Underwriters Laboratories (UL) Inc.. UL is an independent testing and certification body, which also holds its own set of standards (UL standards). Under a reciprocal agreement with Canada the approval is recognized, if the respective Canadian standards are additionally taken into account during the approval process. This can be identified from the small „c“ on the left-hand side of the certification mark.



USA

**ITE (Information Technology Equipment):** Safety of information technology equipment. This certification mark is based on the **UL 60950-1**.



International

**CB-Scheme:** The CB scheme is an international agreement on the mutual recognition of test results between currently approximately 60 national testing organizations in more than 40 countries. It is based on the harmonised IEC standards in conjunction with national variations of these standards. PULS offers a CB scheme in accordance with **IEC 60950-1** for many devices. A uniform report form and an inspection of the labs in accordance with established standards ensure that the testing methods are the same in all labs while guaranteeing the quality of test results. All participating countries have to recognise the CB report and award a national certification mark based on it.



International

**IECEx:** International approval for the use of equipment in areas with potentially explosive atmospheres. This certification mark is based on the **IEC 60079-0**, **IEC 60079-15** and **EN 60079-7** standards.



Europa

**ATEX:** European approval for the use of equipment in areas with potentially explosive atmospheres. This certification mark is based on the **EN 60079-0**, **EN 60079-15** and **EN 60079-7** standards

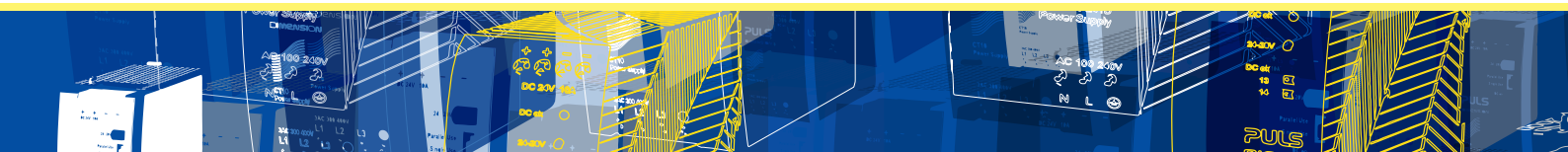





USA, Canada

**Class I Div 2:** US approval for use in areas with potentially explosive atmospheres (Haz. Loc.). This certification mark is based on the ANSI/ISA-12.12.01. The approval may be either provided by UL or CSA.



International

**Germanischer Lloyd:** Prototype testing for the shipbuilding and offshore sector



USA

**ABS:** American Bureau for Shipping: Type testing (PDA) for **shipbuilding or offshore approvals** for the USA.



Russia

TR **EAC registration:** Approval for Russia, Kazakhstan and Belarus



International

**NEC Class 2** - electric circuits are deemed non-hazardous in terms of fire and electrical shock hazards. The advantage of such electric circuits is the significantly reduced effort needed for cabling during installation, which makes them more economical, and the significantly lower amount of testing work required for the approval of the entire system. The power source must either be constructed in accordance with UL 1310 or must be classified and listed as a Limited Power Source (LPS) in accordance with IEC 60950-1.



International

**SEMI F47:** Requirements of the semiconductor industry in terms of mains voltage loss. For example, power supplies may not show signs of output voltage loss at 50% mains voltage for a duration of 200 ms. Such voltage loss may occur when heavy loads are switched on or when supply grids are switched from one to another.



Europe

**EN 50155:** This standard applies to all electronic devices for the control, regulation, protection, supply, etc. that are installed on rail-going vehicles and connected to the accumulator battery of the vehicle or a low-voltage power supply with or without direct connection to the mains voltage.



Europe

**IEC 60601-1:** This standard sets out the requirements for the electrical safety of electrical medical devices and electrical medical systems. Protective measures for patients and users are the primary focus. 2 MOPP (Means Of Patient Protection) in this case stands for two measures for patient protection.



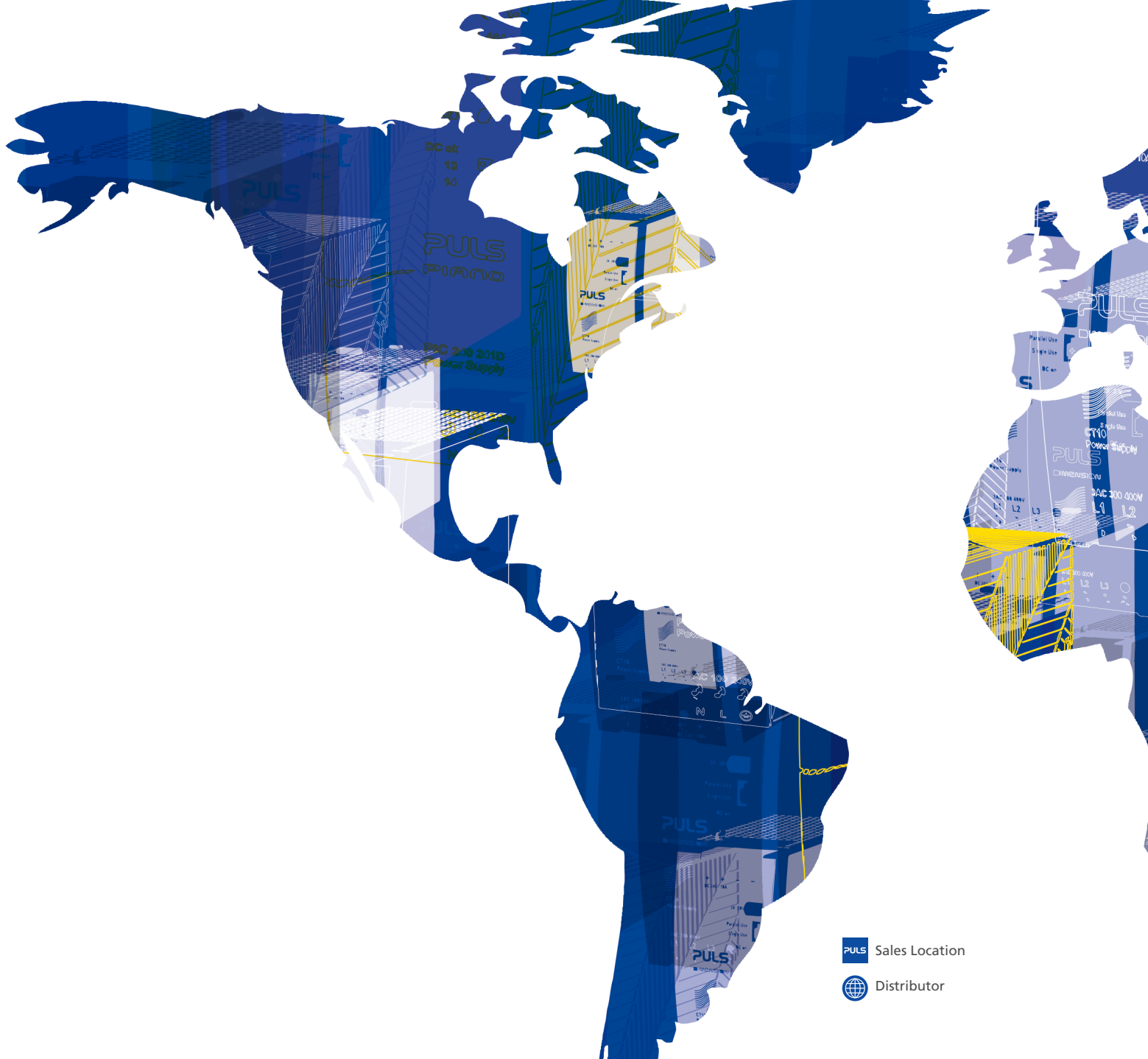

 Sales Location

 Distributor

## PULS GERMANY

### HEADQUARTERS

 PULS GmbH  
Elektrastrasse 6  
81925 München  
Tel. +49 89 9278-0  
info@pulspower.com  
www.pulspower.com

### DELIVERY ADDRESS

PULS GmbH Return Center  
c/o Kühne & Nagel  
Bornaer Str. 205  
09114 Chemnitz

 PULS Vario GmbH  
Venusberger Strasse 44  
09430 Drebach  
+49 37341 4900-10  
office@pulsvario.com  
www.pulsvario.com

## PULS WORLDWIDE

 **Australia**  
Control Logic Pty. Ltd.  
Tel. +61 7 3623 1212  
sales@control-logic.com.au  
www.control-logic.com.au

 **Austria**  
PULS Österreich  
Tel. +43 66 488 207 205  
djenan.custic@pulspower.com  
www.pulspower.com

 **Belgium**  
Elipse nv  
Tel. +32 3 354 5180  
info@elipse.eu  
www.elipse.eu

 **China**  
PULS Trading (Suzhou) Co., Ltd.  
Tel. +86 512 62881820  
contact-sales-suzhou@  
pulspower.com  
www.pulspower.cn

 **Czech Republic**  
OEM Automatic, spol. s.r.o.  
Tel. +420 241 484 940  
info@oem-automatic.cz  
www.oem-automatic.cz

 **Denmark**  
OEM Automatic Klitso A/S  
Tel. +45 70 10 64 00  
info@oemklitso.dk  
www.oemklitso.dk

 **Estonia**  
OEM EESTI OÜ  
Tel. +372 5059849  
info@oem.ee  
www.oem.ee

 **Finland**  
OEM Finland Oy  
Tel. +358 207 499 499  
info@oem.fi  
www.oem.fi

 **France**  
PULS SARL  
Tel. +33 478 66 89 41  
puls@puls-power.fr  
www.pulspower.fr

 **Hungary**  
OEM Automatic Kft.  
Tel. +36 23 880 895  
info@oemautomatic.hu  
www.oemautomatic.hu

 **Iceland**  
Samey ehf.  
Tel. +354 51052-00  
sala@samey.is  
www.samey.is

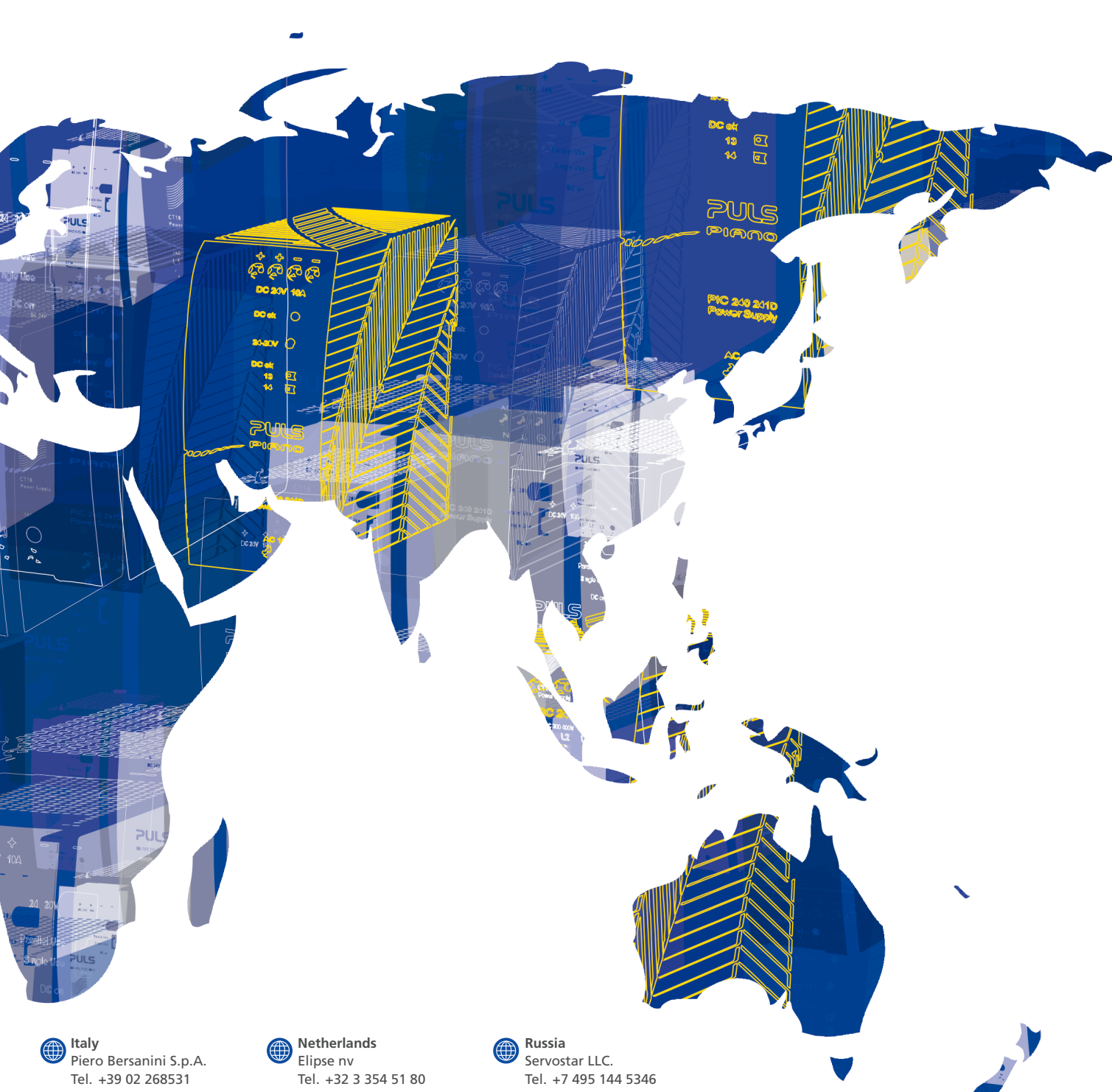



 **Italy**  
Piero Bersanini S.p.A.  
Tel. +39 02 268531  
commerciale@  
pierothersanini.com  
www.pierothersanini.com

 **Japan**  
PULS Ltd  
Tel. +81 (0) 52 211 7062  
info-jp@pulspower.com  
www.pulspower.com

 **Latvia**  
OEM Automatic SIA  
Tel. +372 5295114  
info@oemautomatic.lv  
www.oemautomatic.lv

 **Luxembourg**  
Elipse nv  
Tel. +32 3 354 51 80  
info@elipse.eu

 **Lithuania**  
OEM Automatic UAB  
Tel. +370 640 15878  
info@oem.lt  
www.oem.lt

 **Netherlands**  
Elipse nv  
Tel. +32 3 354 51 80  
info@elipse.eu  
www.elipse.eu

 **North and South America**  
PULS, L.P.  
Tel. +1 630 587 9780  
info@puls-us.com  
www.pulspower.us

 **Norway**  
OEM Automatic AS  
Tel. +47 32 21 05 05  
post@oem.no  
www.oem.no

 **Poland**  
OEM Automatic Sp.z o.o.  
Tel. +48 22 86327-22  
info@pl.oem.se  
www.oemautomatic.pl

 **Portugal**  
Electrónica Olfer, S.L.  
Tel. +351 234 198 052  
info@olfer.com  
www.olfer.com

 **Russia**  
Servostar LLC.  
Tel. +7 495 144 5346  
info@servostar.ru  
http://servostar.ru/

 **Russia**  
Alfa Engineering LLC  
Tel. +7 495 2551614  
Sales@alfai.ru  
www.alfai.ru

 **Singapore**  
PULS Pte Ltd.  
Tel. +65 6684 2310  
contact-sg@pulspower.com  
www.pulspower.sg  
Service for:  
Asia (excluding China),  
Middle East and North Africa

 **Slovakia**  
OEM Automatic, s.r.o  
Tel: +421 33 2400 160  
info@oem-automatic.sk  
www.oem.sk

 **Slovenia**  
Robotina d.o.o.  
Tel. +386 5 689 20-20  
info@robotina.si  
www.robotina.si

 **South Africa**  
Current Automation  
Tel. +27 11 462-4253  
ca@rectifier.co.za  
www.rectifier.co.za

 **Spain**  
Electrónica Olfer, S.L.  
Tel. +34 91 4840850  
info@olfer.com  
www.olfer.com

 **Sweden**  
OEM Automatic AB  
Tel. +46 75 242 41 00  
info@oemautomatic.se  
www.oemautomatic.se

 **Switzerland**  
PULS Schweiz GmbH  
Tel. +41 56 450 18 10  
info@puls-power.ch  
www.puls-power.ch

 **Turkey**  
Klemsan  
Tel. +90 232 877 0800  
info@klemsan.com.tr  
www.klemsan.com.tr

 **Turkey**  
Beckhoff Otomasyon  
Ltd. Şti.  
Tel. +90 216 580 98 30  
www.beckhoff.com.tr  
info@beckhoff.com.tr

 **United Kingdom**  
PULS UK Ltd.  
Tel. +44 1525 841001  
sales@puls.co.uk  
www.pulspower.com

# Footnotes

- a) push-in clamps
- b) spring clamp terminals
- c) screw terminals
- d) enhanced DC input
- e) conformal coating
- f) ATEX approval
- g) NEC Class2
- h) extended lifetime
- i) shut-down input
- j) no DC-OK relay contact
- k) output transient current, see inrush current in datasheet
- l) from +55°C to +70°C
- m) from +60°C to +70°C

You can find detailed technical data in our datasheets

[www.pulspower.com](http://www.pulspower.com)

