



Pneumatic Valve Products

Air Control Valves, Flow Controls & Accessories

Catalog 0600P-13



ENGINEERING YOUR SUCCESS.

Distributor Network, Warning, Offer of Sale**DISTRIBUTION NETWORK**

At Parker, we have the largest global distribution network in motion and control, with over 7,500 distributors serving more than 422,000 customers.

To find the distributor nearest you, please visit our DISTRIBUTOR LOCATOR at <http://www.parker.com/pneu/distributor>



ENGINEERING YOUR SUCCESS.

⚠ WARNING

FAILURE OR IMPROPER SELECTION OR IMPROPER USE OF THE PRODUCTS AND/OR SYSTEMS DESCRIBED HEREIN OR RELATED ITEMS CAN CAUSE DEATH, PERSONAL INJURY AND PROPERTY DAMAGE.

This document and other information from Parker Hannifin Corporation, its subsidiaries and authorized distributors provide product and/or system options for further investigation by users having technical expertise. It is important that you analyze all aspects of your application including consequences of any failure, and review the information concerning the product or system in the current product catalog. Due to the variety of operating conditions and applications for these products or systems, the user, through its own analysis and testing, is solely responsible for making the final selection of the products and systems and assuring that all performance, safety and warning requirements of the application are met.

The products described herein, including without limitation, product features, specifications, designs, availability and pricing, are subject to change by Parker Hannifin Corporation and its subsidiaries at any time without notice.

Offer of Sale

The items described in this document are hereby offered for sale by Parker Hannifin Corporation, its subsidiaries or its authorized distributors. This offer and its acceptance are governed by the provisions stated on the separate page of this document entitled "Offer of Sale".



<p>Product Index, Engineering Data</p>	<p>A Product Index Engineering Data</p>
<p>Direct Acting Valves</p> <p><i>XM Series, 15mm Solenoid Valve</i></p>	<p>B Direct Acting Valves</p>
<p>Inline Valves</p> <p><i>Viking Lite Series, Viking Xtreme Series, "B" Series, Air Saver Unit, ADEX Series, "N" Series</i></p>	<p>C Inline Valves</p>
<p>Subbase & Manifolds Valves</p> <p><i>H Series Micro, Moduflex Series, H Series ISO, Fieldbus Systems, "DX" ISOMAX Series, Valvair II Series</i></p>	<p>D Subbase & Manifold Valves</p>
<p>Manual Mechanical Valves</p> <p><i>Directair 2 & 4 Series, Viking Xtreme Manual Series, "42" Lever / Pedal Series, "MO" Series, Safety, Brass Poppet / Sliding Seal / "PL" / "VL" / "HV" Series, Control Panel Products, Sensing Products</i></p>	<p>E Manual / Mechanical Valves</p>
<p>Accessories</p> <p><i>Flow Controls, Check Valves, Mufflers, Quick Exhaust & Shuttle Valves, Tank Valves, Breather Vents, Silencers, Blocking Valves, Blow Guns, Integrated Fittings</i></p>	<p>F Accessories</p>
<p>Part Number Index, Safety Guide, Offer of Sale</p>	<p>G Page Number Index, Safety Guide, Offer of Sale</p>



For inventory, lead time, and kit lookup, visit www.pdnplu.com

A

Product Index
Engineering Data

Product Index

Engineering Data

Direct Acting Valves

XM Series - Direct Acting



B2

- Inline or stacking
- 1/8 inch ports
- Pressures 0 to 125 PSIG
- Temperatures 32°F to 125°F
- Flow - .15 Cv

15mm Series - Direct Acting



B9

- Subbase or manifold
- 1/8 inch ports
- Pressures VAC to 145 PSIG
- Temperatures 5°F to 140°F
- Flow - .033 to .05 Cv

Inline Valves

Viking Lite Series Valves



C2

- Inline or bar manifold
- 1/8 through 3/8 inch ports
- Pressures 22 to 145 PSIG
- Temperatures 14°F to 122°F
- Flow - .6 to 2.5 Cv

Viking Xtreme Series Valves



C11

- Inline or bar manifold
- 1/8 through 1/2 inch ports
- Pressures VAC to 232 PSIG
- Temperatures -40°F to 140°F
- Flow - .7 to 2.7 Cv

B Series Valves



C41

- Inline, subbase or bar manifold
- 1/8 through 3/4 inch ports
- Pressures VAC to 145 PSIG
- Temperatures 5°F to 120°F
- Flow - .75 to 7.0 Cv

Air Saver Valve Units



C74

- Large reduction in air consumption
- Savings in compressor power consumption
- Reduction in plant CO² emissions
- Big contribution to energy-saving activities
- Improved efficiency

ADEX Series Valves



C83

- Inline, subbase or bar manifold
- M3, M5, 1/8 inch ports
- Pressures VAC to 100 PSIG
- Temperatures 32°F to 122°F
- Flow - .1 to .47 Cv

N Series - Inline Poppet Valves



C96

- Inline mounted
- 3/8 through 1-1/2 inch ports
- Pressures 30 to 250 PSIG
- Temperatures 0°F to 200°F
- Flow - 3.6 to 29.9 Cv



For inventory, lead times, and kit lookup, visit www.pdnplu.com

Subbase & Manifold Valves

H Series Micro Valve

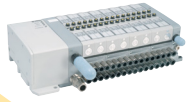

D2

- Subbase or manifold
- 4mm through 1/4 tube
- Pressures VAC to 145 PSIG
- Temperatures 5°F to 120°F
- Flow - .35 Cv

Moduflex Series Valves



D28

- Inline or stacking
- 4mm tube, 1/4, 3/8 inch ports
- Pressures VAC to 120 PSIG
- Temperatures 5°F to 140°F
- Flow - .18 to .80 Cv

H Series ISO Valve



D72

- Subbase or manifold
- 1/8 through 3/4 inch ports
- Pressures VAC to 145 PSIG
- Temperatures 5°F to 120°F
- Flow - .55 to 6.0 Cv

Fieldbus Systems



D138

- Fieldbus interface for H Series and Moduflex valves
- Up to 256 inputs
- Up to 256 outputs
- Digital or analog

DX ISOMAX Series



D203

- Subbase or manifold
- 1/8 through 3/4 inch ports
- Pressures VAC to 145 PSIG
- Temperatures 14°F to 140°F
- Flow - .55 to 4.15 Cv

Valvair II Series



D247

- Subbase or manifold
- 3/8 through 1-1/2 inch ports
- Pressures VAC to 225 PSIG
- Temperatures 0°F to 200°F
- Flow - 1.9 to 12.0 Cv

Manual / Mechanical Valves

Directair 2 & 4



E2

- Manual / mechanical
- 1/8 and 1/4 inch ports
- Pressures VAC to 150 PSIG
- Temperatures 32°F to 175°F
- Flow - .20 to .84 Cv

Viking Xtreme Lever Series



E14

- Manual / mechanical
- 1/8, 1/4 and 3/8 inch ports
- Pressures:
 - Type A & B - VAC to 232 PSIG
 - Type C & D - VAC to 174 PSIG
- Temperatures -40°F to 140°F
- Flow - .5 to 2.7 Cv

42 Lever / Pedal Series



E21

- Manual / mechanical
- 1/4 and 3/8 inch ports
- Pressures VAC to 150 PSIG
- Temperatures 0°F to 140°F
- Flow - 1.3 to 2.9 Cv

MO Series



E24

- Air Pilot, Manual / mechanical
- 1/4 and 1 inch ports
- Pressures VAC to 225 PSIG
- Temperatures -15°F to 200°F
- Flow - .5 to 1.25 Cv

Safety



E52

- LV/EZ shut off valves
- Port sizes 3/8 through 1-1/4 inch
- Max. supply pressure 300 PSIG
- Max. operating temperature 175°F
- Cv from 3.7 to 14
- Two hand tiedown controls

Brass Poppet, Sliding Seal



E62

- 4-way, 3-position rotary disc, direct air operated valves
- Pressures 0 to 150 PSIG
- Temperatures 18°F to 200°F
- Flow - 2.5 to 6.2 Cv

A

Product Index
Engineering Data

Product Index

Engineering Data

Manual / Mechanical Valves

Control Panel Products



E67

- A wide variety of push buttons and selector switches
- Visual indicators
- Foot pedal switches
- Modular pneumatic / electric push buttons

Sensing / Limit Switches



E77

- Limit switches in a variety of sizes and configurations
- Pressure switches with many adjustable ranges
- Components designed specifically for pneumatic technology using pressure variation, air bleed or blocking for detection

Accessories

Flow Control & Check Valves



F2

- Flow controls
 - 1/8 to 1-1/2 inch ports
- Check valves
 - 1/8 to 3/4 inch ports

Misc Accessories



F14

- Exhaust mufflers
- Quick exhaust & shuttle valves
- Blocking valves
- Threshold valves
- Tank valves
- Blow guns

Integrated Fittings



F25

- Flow controls
- Check valves
- Blocking valves

Part Number Index, Safety Guides, Offer of Sale

G2

- Part Number to Page Number Index
- Safety Guide
- Offer of Sale

PNEUMATIC DIVISION E-TOOLS

A
Product Index Engineering Data
Product Index
Engineering Data

Pneumatic Division Part Lookup Tool

Part Lookup Tool Overview

The purpose of this application is to provide users with more in depth detail, such as replacement kits or current inventory for specific pneumatic part numbers. The tool also provides cross reference information for products that have been previously obsoleted. Searches can be made by searching a portion or all of a part number. Use the drop down options available to narrow your search.



Part Lookup Tool Contents

- Replacement KITS by part number
- Obsolete cross reference
- Inventory/stock levels
- Pricing (with distributor login only)
- Bulk part search
- Shipping location
- Lead time

How to access the Tool

U.S. Parker Pneumatic Distributors

- www.pdnpartlookup.com
- Or download the “Distributor Toolbox” app

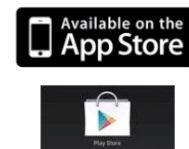
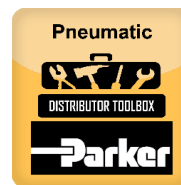

Guest Users

- www.pdnplu.com

Pneumatic Division Size & Selection Calculators

Size, Selection and Cost of Air Calculators Overview

The purpose of this application is to provide users and designers of pneumatic systems with a handy collection of compressed air cost calculators, conversion tools and air valve (Cv) and flow (SCFM) calculations for air cylinder actuation. The size and select calculators are available to anyone for use. See details below.

How to access the Tool

- www.parkerpdncalc.com
- Or download the “Pneumatics” calculator app

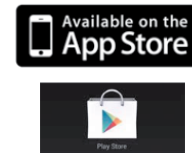
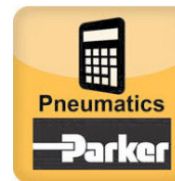

Calculator Contents

- Cost calculator for leaks
- Cost calculator for compressors
- Cost calculator for reverse flow regulators
- Vacuum flow through an orifice
- Air flow through an orifice
- Annual cost of air cylinder operation
- Valve/FRL sizing for cylinder actuation
- And more!



For inventory, lead time, and kit lookup, visit www.pdnplu.com

A

Product Index
Engineering Data

Product Index

Engineering Data

The Parker 5-Year Extended Warranty

Parker Hannifin Corporation will extend its warranty on all pneumatic components to sixty (60) months providing they are correctly installed and protected by Parker pneumatic filters which are properly maintained. Components covered by this warranty include all cylinders, valves, and pneumatic automation components manufactured by Parker in any of our global facilities. This warranty covers our components anywhere in the world you may ship your equipment.

Parker's obligation under this warranty is limited to the replacement or repair of any failed components. The buyer understands that the seller will not be liable for any other costs or damages.

The buyers of quality Parker components and filters benefit by having ONE source for all pneumatic needs - **Parker**.



Andrew M. Weeks
President
Motion Systems Group



For inventory, lead times, and kit lookup, visit www.pdnplu.com

Application Engineering Data

Engineering Data

Selection Guide	A2
Fluid Power Graphic Symbols	A3
Direct Acting Solenoid Valves	A4
Solenoid Air Pilot Valves	A5-A7
Manual Valves	A8
IP Ratings, Symbols	A9
ISO Mounting Information	A10

A

**Product Index
Engineering Data**

**Product
Index**

**Engineering
Data**



For inventory, lead time, and kit lookup, visit www.pdnplu.com

A

**Product Index
Engineering Data**

Product Index

Engineering Data

Saving Money and Space by Sizing Your Valves Properly

This catalog gives you a flow rating (Cv) for each valve in the Parker Hannifin line. You can “plug” your requirements into the following simple formula, and determine the Cv needed to do the job. By not oversizing, you’ll save space and money, and you’ll ensure the valve you select will do the job.

Converting the Job Requirements Into Cv (Capacity Co-efficient).

$$Cv = \frac{\text{Cylinder Area (Sq. In.)} \times \text{Stroke (In.)} \times \text{Compression Factor (Table 2)} \times \text{“A” (Table 2)}}{\text{Stroke Time (sec.)} \times 28.8}$$

Let’s work through an example:

We want to extend a 3 1/4" bore cylinder which has a 12" stroke in one second, and we have a supply pressure of 80 PSI to do the work. Here’s what we know:

- Cylinder Area for a 3-1/4" Bore, from Table 1 8.30 sq. in.
- Cylinder Stroke 12 in.
- Stroke Time Required in Seconds 1 sec.
- Compression Factor at 80 PSI, from Table 2 6.4
- “A” Constant for 80 PSI, from Table 2048

Substituting in the formula, we have:

$$Cv = \frac{8.30 \times 12 \times 6.4 \times .048}{1 \times 28.8} = 1.06$$

Any valve, therefore, which has a Cv of at least 1.06, will extend our cylinder the specified distance in the required time.

Choosing the Valve “Series”

Your next step is to choose a basic valve design to do the job. For a quick guide to valve designs, see Table 3.

Having selected the basic valve design, consult the Capacity Co-efficient (Cv) tables which describe the individual valve capacities.

Selecting the Valve Model, Options and Accessories

Having determined Cv, series, port size, flow-path configuration (pre-determined by circuit design), and actuation method, you’re ready to choose the exact valve model number.

Read the pertinent catalog pages; note the exact model numbers, options and accessories you want. Then phone or write your Parker Hannifin air valve distributor. They will give you prompt, accurate service.

Note: Need circuit design help? Contact your local Parker Hannifin distributor. They are backed up by our regional Sales Engineers and offices. Between them, you’ll find answers to all of your questions.

Table 1

Effective Square-Inch Areas for Standard-Bore-Size Cylinders

Bore Size	Cylinder Area (Sq. In.)	Bore Size	Cylinder Area (Sq. In.)
3/4"	.44	4"	12.57
1"	.79	4-1/2"	15.90
1-1/8"	.99	5"	19.64
1-1/4"	1.23	6"	28.27
1-1/2"	1.77	7"	38.48
1-3/4"	2.41	8"	50.27
2"	3.14	10"	78.54
2-1/2"	4.91	12"	113.10
3-1/4"	8.30	14"	153.94
3-5/8"	10.32		

**Table 2
Compression Factors and “A” Constants**

Inlet Pressure (PSIG)	Compression Factor	“A” Constants for Various Pressure Drop*		
		2 PSI ΔP	5 PSI ΔP	10 PSI ΔP
10	1.6	.152	.103	
20	2.3	.126	.084	.065
30	3.0	.111	.073	.055
40	3.7	.100	.065	.048
50	4.4	.091	.059	.044
60	5.1	.085	.055	.040
70	5.7	.079	.051	.037
80	6.4	.075	.048	.035
90	7.1	.071	.046	.033
100	7.8	.068	.044	.032
110	8.5	.065	.042	.030
120	9.2	.063	.040	.029
130	9.9	.061	.039	.028
140	10.6	.058	.037	.027
150	11.2	.057	.036	.026
160	11.9	.055	.035	.025
170	12.6	.053	.034	.024
180	13.3	.052	.033	.024
190	14.0	.051	.032	.023
200	14.7	.050	.032	.023

Note: Use “A” constant at 5 PSI ΔP for most applications. On very critical applications, use “A” at 2 PSI ΔP. You will find in many cases, a 10 PSI ΔP is not detrimental, and can save money and mounting space.

* Tabulated values are the solution of $\frac{1}{22.48} \sqrt{\frac{GT}{(P_1 - P_2) P_2}}$ where T is for 68°F and G = 1 for Air.

**Table 3
Characteristics of the Major Valve Designs**

<p>A. Poppet 3-Way and 4-Way</p>	<ol style="list-style-type: none"> High flow capacities Minimum lubrication requirements Fast response Self-cleaning poppet seats Pressures of 15 to 150 PSIG (modifications for vacuum to 250 PSIG)
<p>B. Spool Valves (WCS) 3-Way and 4-Way</p>	<ol style="list-style-type: none"> Low friction Lower operating pressures Fast response Less wear Long Cycle Life - Under pressure, radial expansion of the seal occurs to maintain sealing contact with the valve bore Non-Lube Service - No lubrication required for continuous valve shifting Bi-Directional Spool Seals - Common spool used for any pressure, including vacuum
<p>C. Packed Bore 4-Way</p>	<ol style="list-style-type: none"> Wide range of flow capacities Wide range of flow-path configurations Pilot-operated models available Pressures of vacuum to 150 PSIG
<p>D. Rotary Or Reciprocating Disc 4-Way, manually operated</p>	<ol style="list-style-type: none"> Inexpensive Versatility in manual actuation

Cv – Capacity Co-efficients (sometimes called Flow Factors). Each flow path through the valve has its own Cv value. All Cv ratings for each valve cataloged on this page are listed on the front side of this sheet.

Q = Flow in Standard Cubic Feet per minute (14.7 PSIA at 60°F)
 $Cv = \frac{Q}{22.48} \sqrt{\frac{GT}{(P_1 - P_2) P_2}}$
 P₁ = Inlet Absolute Pressure (gauge pressure + 14.7)
 P₂ = Outlet Absolute Pressure (gauge pressure + 14.7)
 Note: P₂ must be greater than .53 x P₁
 G = Specific Gravity of flowing medium (Air, G = 1)
 T = Absolute Temperature of Air (460 + °F)

Cv = Q x “A” (Table 2)



For inventory, lead times, and kit lookup, visit www.pdnplu.com

Air Preparation Units

Symbol Description

	Filter / Separator with manual drain
	Filter / Separator with automatic drain
	Oil Removal Filter
	Automatic Drain
	Lubricator less drain
	Lubricator with manual drain
	Lubricator with automatic filling
	Air Line Pressure Regulator adjustable, relieving
	Air Line Pressure Regulator pilot controlled, relieving
	Filter / Regulator (piggyback) manual drain relieving (with gauge)
	Filter / Regulator (piggyback) auto drain relieving
	Air Line Combo F-R-L simplified

Pneumatic Valves

Symbol Description

	Check
	Flow Control
	Relief Valve
	2-Position, 2-Way
	2-Position, 3-Way
	2-Position, 4-Way
	2-Position, 4-Way 5-Ported

Pneumatic Valves

Symbol Description

	3-Position, 4-Way, APB ports closed, center pos.
	3-Position, 4-Way, CE 5-Ported cylinder ports open to exhaust in center position
	3-Position, 4-Way, PC 5-Ported pressure port open to cylinder ports in center position
	Quick Exhaust
	Shuttle

Valve Actuators

Symbol Description

	Manual general symbol
	Push Button
	Lever
	Pedal or Treadle
	Mechanical cam, toggle, etc.
	Spring
	Detent line indicates which detent is in use
	Piezo
	Solenoid
	Internal Pilot Supply
	Remote Pilot Supply complete
	Remote Pilot Supply simplified
	And / Or Composite solenoid and pilot or manual override
	And / Or Composite solenoid and pilot or manual override and pilot

Cylinders

Symbol Description

	Standard double acting
	Single Acting
	Double Rod
	Spring Return
	Ram Type
	Telescope
	Tandum
	Duplex

Lines and Functions

Symbol Description

	Solid Line - Main Line
	Dashed Line - Pilot Line
	Dotted Line - Exhaust or Drain Line
	Center Line - Enclosure Outline
	Lines Crossing (90° intersection not necessary)
	Lines Joining (90° intersection not necessary)
	Lines Joining
	Flow Direction hydraulic medium
	Flow Direction gaseous medium
	Energy Source
	Line with Fixed Restriction
	Line with Adjustable Restriction
	Flexible Line
	Plugged Port, Test Station, Power Take-off
	connected Quick Disconnect Without Checks
	disconnected Quick Disconnect Without Checks
	connected Quick Disconnect With Checks
	disconnected Quick Disconnect With Checks
	connected Quick Disconnect With One Check
	disconnected Quick Disconnect With One Check

A

Product Index
Engineering Data

Product Index

Engineering Data



For inventory, lead time, and kit lookup, visit www.pdnplu.com

A

Product Index
Engineering Data

Product Index

Engineering Data

3-Way, 2-Position, Normally Closed

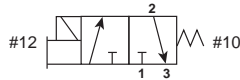

De-energized position – Solenoid #12 de-energized. Pressure at inlet port 1 blocked, outlet port 2 connected to exhaust port 3.

Energized position – Solenoid #12 energized. Pressure at inlet port 1 is connected to outlet port 2, exhaust port 3 is blocked.

3-Way, 2-Position, Normally Open

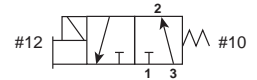

De-energized position – Solenoid #12 de-energized. Pressure at inlet port 3 connected to outlet port 2, exhaust port 1 is blocked.

Energized position – Solenoid #12 energized. Pressure at inlet port 3 blocked, outlet port 2 connected to exhaust port 1.

3-Way, 2-Position, Diverter

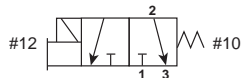

De-energized position – Solenoid #12 de-energized. Pressure at inlet port 2 connected to outlet port 3. Port 1 is blocked.

Energized position – Solenoid #12 energized. Pressure at inlet port 2 is connected to outlet port 1. Port 3 is blocked.

3-Way, 2-Position, Selector

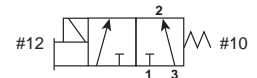

De-energized position – Solenoid #12 de-energized. Pressure at inlet port 1 is blocked. Pressure at inlet port 3 is connected to outlet port 2.

Energized position – Solenoid #12 energized. Pressure at inlet port 1 is connected to outlet port 2. Pressure at port 3 is blocked.

2-Way, 2-Position, Normally Closed

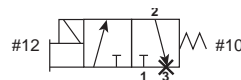

De-energized position – Solenoid #12 de-energized. Pressure at inlet port 1 blocked, port 2 is connected to port 3, which is plugged.

Energized position – Solenoid #12 energized. Pressure at inlet port 1 is connected to outlet port 2. Port 3 is blocked.

X Plug port 3.

2-Way, 2-Position, Normally Open

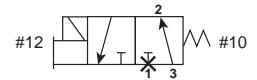

De-energized position – Solenoid #12 de-energized. Pressure at inlet port 3 is connected to outlet port 2. Port 1 is blocked.

Energized position – Solenoid #12 energized. Pressure at inlet port 3 is blocked. Port 2 is connected to port 1, which is plugged.

X Plug port 1.

4-Way, 2-Position

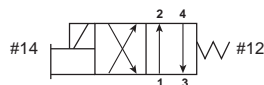

De-energized position – Solenoid #14 de-energized. Pressure at inlet port 1 connected outlet port 2. Outlet port 4 connected to exhaust port 3.

Energized position – Solenoid #14 energized. Pressure at inlet port 1 is connected to outlet port 4. Outlet port 2 connected to exhaust port 3.

4-Way, 2-Position with Flow Controls

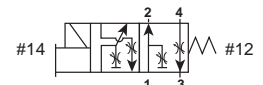

De-energized position – Solenoid #14 de-energized. Pressure at inlet port 1 connected outlet port 2. Outlet port 4 connected to exhaust port 3.

Energized position – Solenoid #14 energized. Pressure at inlet port 1 is connected to outlet port 4. Outlet port 2 connected to exhaust port 3.

Flow Controls meter exhaust from ports 2 and 4 separately into port 3.



For inventory, lead times, and kit lookup, visit www.pdnplu.com

**Single Solenoid
 4-Way, 2-Position**

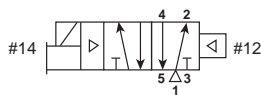

De-energized position – Solenoid operator #14 de-energized. Pressure at inlet port 1 connected to outlet port 2. Outlet port 4 connected to exhaust port 5.

Energized position – Solenoid operator #14 energized. Pressure at inlet port 1 connected to outlet port 4. Outlet port 2 connected to exhaust port 3.

**Double Solenoid
 4-Way, 2-Position**

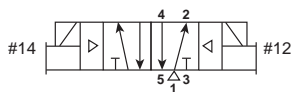

Solenoid operator #14 energized last. Pressure at inlet port 1 connected to outlet port 4. Outlet port 2 connected to exhaust port 3.

Solenoid operator #12 energized last. Pressure at inlet port 1 connected to outlet port 2. Outlet port 4 connected to exhaust port 5.

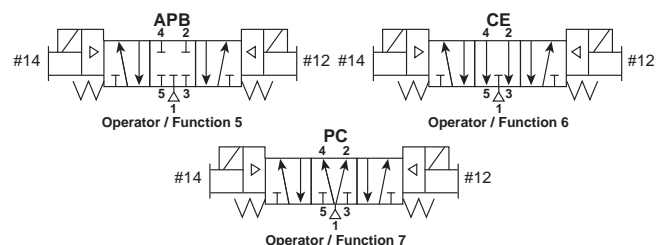

**Double Solenoid
 4-Way, 3-Position**

With #12 operator energized – inlet port 1 connected to cylinder port 2, cylinder port 4 connected to exhaust port 5.

With #14 operator energized – inlet port 1 connected to cylinder port 4, cylinder port 2 connected to exhaust port 3.

Function 5: All Ports Blocked
 All ports blocked in the center position.

Function 6: Center Exhaust
 Cylinder ports 2 and 4 connected to exhaust ports 3 and 5 in center position. Port 1 is blocked.

Function 7: Pressure Center
 Pressure port 1 connected to cylinder ports 2 and 4, and exhaust ports 3 and 5 blocked in center position.

Dual Pressure:

May be used for dual pressure service with pressure at ports 3 & 5. (Use either external pilot source option “K”, “W” or “X”, or dual pressure pilot source option “D” or “E.”) If pilot source “D” or “E” is selected, the high pressure must be at port #3. If pilot source “K”, “W” or “X” is selected, the external pilot must be plumbed to port #14 or “X” respectively. Note: The “B6” valve is also available with dual pressure using Port 5 for high pressure (Option “G” & “H”). This is only to be used if converting from a “42” (“CM”) Series traditional valve.

In the 3-Position valve, the effect of dual pressure is extremely important when the valve is in the center position, as the CE and PC functions are reversed. Therefore, care should be used when selecting a 3-Position valve.

**Single Remote Pilot
 4-Way, 2-Position**

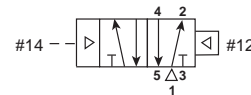

Normal position – Pressure at inlet port 1 connected to outlet port 2. Outlet port 4 connected to exhaust port 5.

Operated position – Maintained air signal at port 14. Pressure at inlet port 1 connected to outlet port 4. Outlet port 2 connected to exhaust port 3.

**Double Remote Pilot
 4-Way, 2-Position**

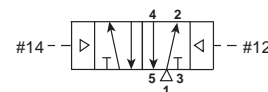

Momentary air signal at port 14 last. Pressure at inlet port 1 connected to outlet port 4. Outlet port 2 connected to exhaust port 3.

Momentary air signal at port 12 last. Pressure at inlet port 1 connected to outlet port 2. Outlet port 4 connected to exhaust port 5.

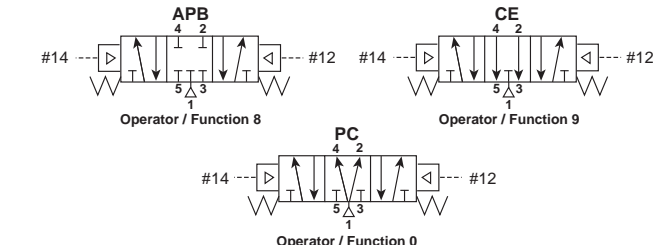

**Double Remote Pilot
 4-Way, 3-Position**

With #12 operator signaled – inlet port 1 connected to cylinder port 2, cylinder port 4 connected to exhaust port 5.

With #14 operator signaled – inlet port 1 connected to cylinder port 4, cylinder port 2 connected to exhaust port 3.

Function 8: All Ports Blocked
 All ports blocked in the center position.

Function 9: Center Exhaust
 Cylinder ports 2 and 4 connected to exhaust ports 3 and 5 in center position. Port 1 is blocked.

Function 0: Pressure Center
 Pressure port 1 connected to cylinder ports 2 and 4, and exhaust ports 3 and 5 blocked in center position.

A

Product Index
Engineering Data

Product Index

Engineering Data

Single Solenoid
3-Way, 2-Position, NC (NNP)

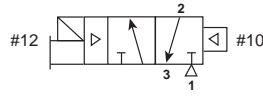

Normally Closed:

De-energized position – Solenoid #12 de-energized. Pressure at inlet port 1 blocked, outlet port 2 connected to exhaust port 3.

Energized position – Solenoid #12 energized. Pressure at inlet port 1 connected to outlet port 2, exhaust port 3 is blocked.

Single Solenoid
3-Way, 2-Position, NO (NP)



Normally Open:

De-energized position – Solenoid #10 de-energized. Pressure at inlet port 1 connected to outlet port 2, exhaust port 3 is blocked.

Energized position – Solenoid #10 energized. Pressure at inlet port 1 blocked, outlet port 2 connected to exhaust port 3.

Double Solenoid
3-Way, 2-Position

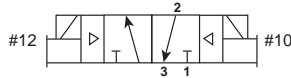

Solenoid operator #12 energized last. Pressure at inlet port 1 connected to outlet port 2, exhaust port 3 is blocked.

Solenoid operator #10 energized last. Pressure at inlet port 1 blocked, outlet port 2 connected to exhaust port 3.

Single Remote Pilot
3-Way, 2-Position, NC (NNP)

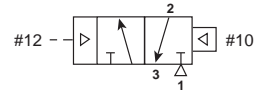

Normally Closed:

Normal position – Pressure at inlet port 1 blocked, outlet port 2 connected to exhaust port 3.

Operated position – Maintained air signal at port 12. Pressure at inlet port 1 connected to outlet port 2, exhaust port 3 is blocked.

Single Remote Pilot
3-Way, 2-Position, NO (NP)

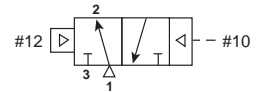

Normally Open:

Normal position – Pressure at inlet port 1 connected to outlet port 2, exhaust port 3 is blocked.

Operated position – Maintained air signal at port 10. Pressure at inlet port 1 blocked, outlet port 2 connected to exhaust port 3.

Double Remote Pilot
3-Way, 2-Position

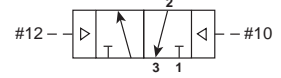

Momentary air signal at port 12 last. Pressure at inlet port 1 connected to outlet port 2, exhaust port 3 is blocked.

Momentary air signal at port 10 last. Pressure at inlet port 1 blocked, outlet port 2 connected to exhaust port 3.



**Double Solenoid / Remote Pilot
 Dual 3-Way, 2-Position NC / NC (NNP)**

With #14 & #12 operators both de-energized – pressure at inlet port 1 blocked, outlet port 4 connected to exhaust port 5, outlet port 2 connected to exhaust port 3.

With #14 operator energized – pressure at inlet port 1 connected to outlet port 4, exhaust port 5 blocked, outlet port 2 connected to exhaust port 3.

With #12 operator energized – pressure at inlet port 1 connected to outlet port 2, exhaust port 3 blocked, outlet port 4 connected to exhaust port 5.

With #14 & #12 operators both energized – pressure at inlet port 1 connected to outlet ports 4 & 2, exhaust ports 3 & 5 blocked.

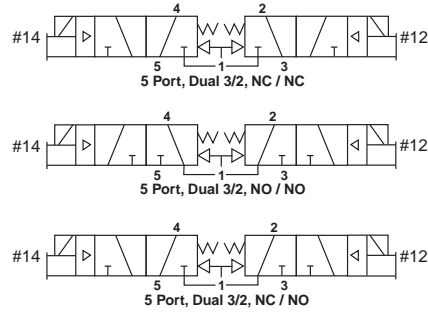

Dual 3/2 valves replace 3-position valves for better performance

**3-position
 center exhaust**

A traditional 5/3 center exhaust valve is now replaced by a double 3/2 NC+NC valve module. Both cylinder chambers are exhausted and rod and piston are free to move.

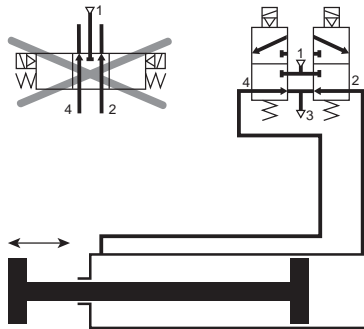

**3-position
 pressure center**

A traditional 5/3 pressure center valve is now replaced by a double 3/2 NO+NO valve module. The function is identical.

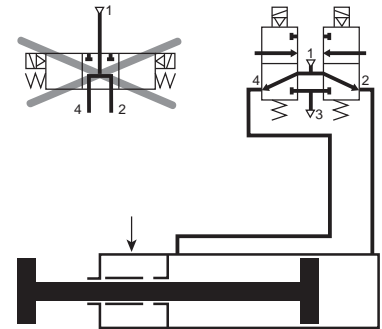

A

Product Index
Engineering Data

Product Index

Engineering Data

Lever Valves – Parallel & Perpendicular Operated

2-Position, Spring Return

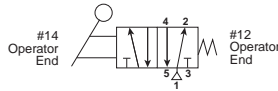

Single Pressure at Port #1 – The Hand Lever alternately pressurizes port 2 or 4 while exhausting at port 3 or 5. When actuating Hand Lever, port 4 is pressurized; when releasing Hand Lever, spring returns the spool, pressurizing port 2.

Dual Pressure – Pressure at port 3 & 5 alternately pressurizes port 2 or 4 while exhausting at port 1. When actuating Hand Lever, port 2 is pressurized; when releasing Hand Lever, spring returns the spool, pressurizing port 4. (Must be ordered as dual pressure)

2-Position, Detent

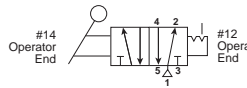

Single Pressure at Port #1 – The Hand Lever alternately pressurizes port 2 or 4 while exhausting at port 3 or 5. When pulling Hand Lever, port 4 is pressurized; when pushing Hand Lever, port 2 is pressurized. Spool stays in last actuated position.

Dual Pressure – Pressure at port 3 & 5 alternately pressurizes port 2 or 4 while exhausting at port 1. When pulling Hand Lever, port 2 is pressurized; when pushing Hand Lever, port 4 is pressurized. Spool stays in last actuated position. (Must be ordered as dual pressure.)

Foot Pedal Operated

2-Position, Spring Return

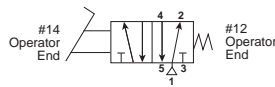

CAUTION:
 This valve shall not be used to actuate a punch press.
 Do not use this valve on punch presses or press brakes.
 See OSHA 1910.217.

See Dimension page for Pedal Guard Kit.

Single Pressure at Port #1 – The Foot Pedal alternately pressurizes port 2 or 4 while exhausting at port 3 or 5. When pressing Foot Pedal down, port 4 is pressurized; when releasing Foot Pedal, spring returns the spool, pressurizing port 2.

Dual Pressure – Pressure at port 3 & 5 alternately pressurizes port 2 or 4 while exhausting at port 1. When pressing Foot Pedal down, port 2 is pressurized; when releasing Foot Pedal, spring returns the spool, pressurizing port 4. (Must be ordered as dual pressure)

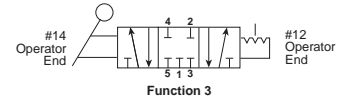

Function 3

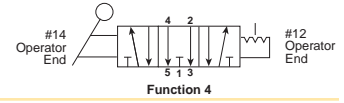

Function 4

3-Position, Detent

Single Pressure at Port #1 – The Hand Lever alternately pressurizes port 2 or 4 while exhausting at port 3 or 5. When pulling Hand Lever, port 4 is pressurized; when pushing Hand Lever, port 2 is pressurized. When Hand Lever is vertical, it is in the center position - either APB or CE. Spool stays in last actuated position.

Center Functions

All Ports Blocked – Function 3

Center Exhaust – Function 4

CAUTION:
 For 3-Position lever function, do not restrict exhaust ports with speed controls.



Electrical Enclosure IP Ratings

		2nd Numeral: Degree of protection with respect to harmful ingress of water								
		0	1	2	3	4	5	6	7	8
1st Numeral: Degree of Protection with respect to persons and solid objects		Non Protected	Protected against dripping water	Protected against dripping water of ±15° angle	Protected against spraying water of ±60° angle	Protected against splashing water	Protected against water jets	Protected against heavy seas	Protected against immersion	Protected against submersion
Non-Protected	0	IP00	IP01	IP02						
Protected against solid objects greater than Ø50mm	1	IP10	IP11	IP12	IP13					
Protected against solid objects greater than Ø12mm	2	IP20	IP21	IP22	IP23					
Protected against solid objects greater than Ø2.5mm	3	IP30	IP31	IP32	IP33	IP34				
Protected against solid objects greater than Ø1.0mm	4	IP40	IP41	IP42	IP43	IP44	IP45	IP46		
Dust protected Depression 200mm water column, air flow 80 x volume of enclosure	5					IP54	IP55	IP56		
Dust-tight Same test procedure	6						IP65	IP66	IP67	IP68

A

Product Index
Engineering Data

Product Index

Engineering Data

Functionality Explanation

Fluid Power		Universal Description		Electrical	
Function	Symbol			Function	Symbol
Normally Closed (N.C.)	2-Way 	3-Way 	Normally Non-Passing (NNP)	Normally Open (N.O.)	
	Normally Open (N.O.)	2-Way 			



For inventory, lead time, and kit lookup, visit www.pdnplu.com



International Standards Organization

Crafted a set of rules you must follow to call your product an “ISO valve”.
In valves ISO standard identifies the pneumatic interface between valve and the base.
Defines pattern of mounting screws.
Allows products to be interchangeable between manufacturers.

15407-1

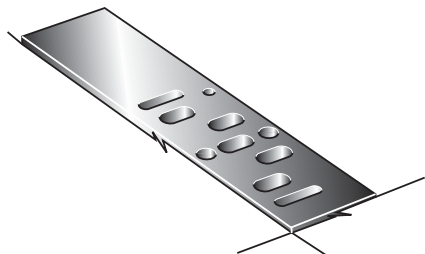

External Electrical Connection Subbase Valves

The ISO Standard 15407-1 specifies an interface pattern for a common subbase valve consisting of pressure passages 1, 3, 5, 2, & 4, pilot passages 12 & 14. The width of the pattern and location of the 2-bolt holes are also specified. This ISO standard specifies 2 different sizes – 18mm as the smallest and 26mm as the largest.

15407-2

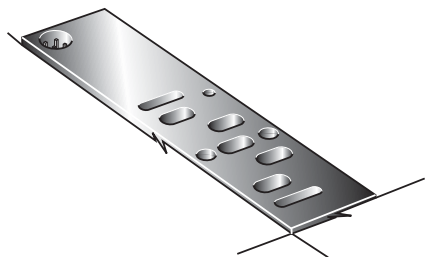

Body-to-Base Plug-In Subbase Valves

The ISO Standard 15407-2 specifies an interface pattern for a common subbase valve consisting of pressure passages 1, 3, 5, 2, & 4, pilot passages 12 & 14, and a plug-in electrical connector. The width of the pattern and location of the 2-bolt holes are also specified. This ISO standard specifies 2 different sizes – 18mm as the smallest and 26mm as the largest.

5599-1

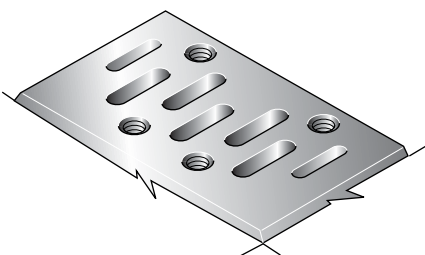

External Electrical Connection Subbase Valves

The ISO Standard 5599-1 specifies an interface pattern for a common subbase valve consisting of pressure passages 1, 3, 5, 2, & 4, and pilot passages 12 & 14. The width of the pattern and location of the 4 bolt holes are also specified. There are no specifications for the type of external electrical connection used to control the valve.

5599-2

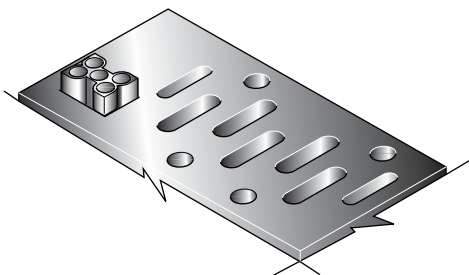

Body-to-Base Plug-In Subbase Valves

The ISO Standard 5599-2 specifies an interface pattern for a common subbase valve consisting of pressure passages 1, 3, 5, 2, & 4, pilot passages 12 & 14, and a plug-in electrical connector. The width of the pattern and location of the 4-bolt holes are also specified. This ISO standard specifies 6 different sizes – 1 as the smallest up to 6 as the largest. Manufacturers who produce ISO 5599-2 valves typically offer sizes 1, 2 & 3.



Pneumatic Valve Products
Direct Acting Valve Series

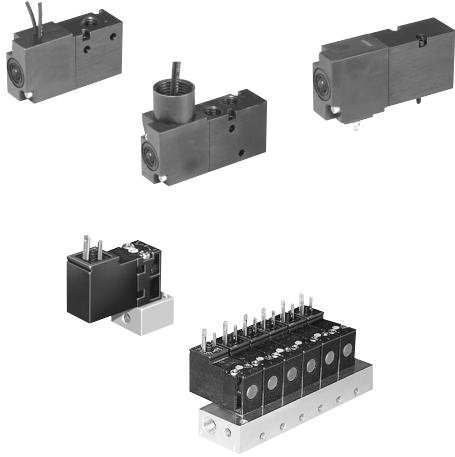

XM Series

Features	B1
Common Part Number / Ordering Information	B3-B5
Accessories	B6
Technical Data	B7
Dimensional Data	B8

15mm Solenoid Valve

Features	B9
Ordering Information	B10-B11
Dimensional Data	B11

B

Direct Acting Valves



Features

XM Valve Series

XM series is a 1/8 inch ported, 3-way and 4-way, 2-position, spring return, normally open or normally closed, general purpose air valve.

Ports

- 1/8" NPT

Mounting

- Inline
- IEM bar manifold
- Subbase valve manifold

Solenoids

- Continuous duty rated
- 24" grommet
- 15mm 3-pin (9.4mm pin spacing)
- 1/2" conduit
- 12VDC to 240VAC

Balanced poppet

- 3-way N.O. & N.C.
- Diverter
- Selector
- Vacuum option

ROHS compliant

Material specifications

Body	Aluminum
Center post and armature	Stainless steel
Stem	Brass
Spring	Stainless steel
Seals	Buna N
Center post sleeve	Acetal
Coil	General purpose Class B, encapsulated

Performance information

Code	Voltage			Power consumption (W / VA)	Holding current (Amps)	Flow	
	AC	DC				Cv chart	
						3-way	4-way
	60Hz	50Hz					
42	24	22	—	4.8VA	.200	.15	.15
45*	—	—	12	4.5W	.375	.15	.15
49	—	—	24	4.5W	.188	.15	.15
53	120	110	—	4.32VA	.036	.15	.15
57	240	220	—	4.32VA	.018	.15	.15

* Mobile voltage, +25/-30%
 Note: Voltage tolerance: +10 / -15%
 Cv tested per ANSI / (NFPA) T3.21.3

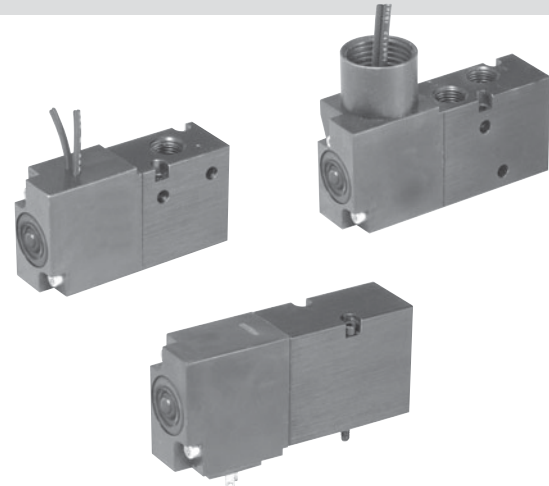

Operating information

3-way, N operating pressure:	0 to 125 PSIG
3-way, V* operating pressure:	0.28" Hg to 125 PSIG
4-way, N operating pressure:	0.28" Hg to 125 PSIG
Temperature range:	32°F to 125°F (0°C to 50°C)

* For vacuum service

Response time

Code	Voltage	0 Cu. in. test chamber		12 Cu. in. test chamber	
		Fill	Exhaust	Fill	Exhaust
49	24VDC	.011	.007	.240	.384
53	120VAC	.011	.020	.240	.384







Average Fill Time (Seconds): With 100 PSIG supply, time required to fill from 0-90 PSIG and exhaust from 100 PSIG to 10 PSIG is measured from instant of energizing, or de-energizing solenoid. Times shown are average.
 Tested per ANSI / (NFPA) T3.21.8.

B
 Direct Acting Valves
 XM Series
 15mm Solenoid Valves







For inventory, lead times, and kit lookup, visit www.pdnplu.com

3-way Inline Valves

	Symbol	Port size	Cv	Voltage	Valve type	Weight	Part number
		1/8"	.15	24" Grommet, 24VDC	Inline	4 oz	XM30NBG49A
		1/8"	.15	24" Grommet, 120VAC	Inline	(.11 Kg)	XM30NBG53A
		1/8"	.15	3-Pin, 15mm, DIN 9.4mm, 24VDC	Inline	4 oz	XM30NB549A
		1/8"	.15	3-Pin, 15mm, DIN 9.4mm, 120VAC	Inline	(.11 Kg)	XM30NB553A
		1/8"	.15	1/2" Conduit / 24" leads, 24VDC	Inline	5 oz	XM30NBH49A
		1/8"	.15	1/2" Conduit / 24" leads, 120VAC	Inline	(.14 Kg)	XM30NBH53A

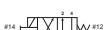

Note: All units with non-locking flush override. Can be used as N.O / N.C. / Diverter / Selector function.

4-way Inline Valves

	Symbol	Port size	Cv	Voltage	Valve type	Weight	Part number
		1/8"	.15	24" Grommet, 24VDC	Inline	4.3 oz	XM40NBG49A
		1/8"	.15	24" Grommet, 120VAC	Inline	(.12 Kg)	XM40NBG53A
		1/8"	.15	3-Pin, 15mm, DIN 9.4mm, 24VDC	Inline	4.3 oz	XM40NB549A
		1/8"	.15	3-Pin, 15mm, DIN 9.4mm, 120VAC	Inline	(.12 Kg)	XM40NB553A
		1/8"	.15	1/2" Conduit / 24" leads, 24VDC	Inline	5.3 oz	XM40NBH49A
		1/8"	.15	1/2" Conduit / 24" leads, 120VAC	Inline	(.15 Kg)	XM40NBH53A

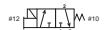

Note: All units with non-locking flush override.

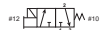
3-way Subbase Mount Valves

	Symbol	Port size	Cv	Voltage	Valve type	Weight	Part number
		1/8"	.15	24" Grommet, 24VDC	Subbase mount	4 oz	XM3VNBG49A
		1/8"	.15	24" Grommet, 120VAC	Subbase mount	(.11 Kg)	XM3VNBG53A
		1/8"	.15	3-Pin, 15mm, DIN 9.4mm, 24VDC	Subbase mount	4 oz	XM3VNB549A
		1/8"	.15	3-Pin, 15mm, DIN 9.4mm, 120VAC	Subbase mount	(.11 Kg)	XM3VNB553A

Note: All units with non-locking flush override. Can be used as N.O / N.C. / Diverter / Selector function.

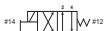
4-way Subbase Mount Valves

	Symbol	Port size	Cv	Voltage	Valve type	Weight	Part number
		1/8"	.15	24" Grommet, 24VDC	Subbase mount	4.3 oz	XM4VNBG49A
		1/8"	.15	24" Grommet, 120VAC	Subbase mount	(.12 Kg)	XM4VNBG53A
		1/8"	.15	3-Pin, 15mm, DIN 9.4mm, 24VDC	Subbase mount	4.3 oz	XM4VNB549A
		1/8"	.15	3-Pin, 15mm, DIN 9.4mm, 120VAC	Subbase mount	(.12 Kg)	XM4VNB553A

Note: All units with non-locking flush override.

 Most popular.



For inventory, lead time, and kit lookup, visit www.pdnplu.com

Model Number Index

B
 Direct Acting Valves
 XM Series
 15mm Solenoid Valves

XM 4 0 N B G49 — A

Operator / Function	
3-Way, Direct Operated, Single Solenoid, Spring Return	3
4-Way, Direct Operated, Single Solenoid, Spring Return	4

Port Size / Thread Type	
1/8" NPT Inline	0*
Subbase Valve Less Base	V

* Available on IEM manifolds.

Pilot Source / Exhaust	
Direct Operated / Standard Pressure	N*
Direct Operated / Vacuum Service	V**

* 3-Way Valve Positive Pressure,
 4-Way Valve Vacuum or Positive Pressure
 ** 3-Way Valve Vacuum Pressure.

Overrides	
Flush - Non-Locking	B

Engineering Level	
A	Current

Options	
Blank	None
F0*	Flow Control

* 4-Way Valves Only.

Enclosures / Lead Length				
		Voltage		
		AC		DC
		60Hz	50Hz	
542	15mm 3-Pin DIN 9.4mm	24	22	
545*	15mm 3-Pin DIN 9.4mm			12
549	15mm 3-Pin DIN 9.4mm			24
553	15mm 3-Pin DIN 9.4mm	120	110	
G42	Grommet / Flying Leads 24"	24	22	
G45*	Grommet / Flying Leads 24"			12
G49	Grommet / Flying Leads 24"			24
G53	Grommet / Flying Leads 24"	120	110	
G57	Grommet / Flying Leads 24"	240	220	
H42†	1/2" Conduit / Flying Leads 24"	24	22	
H45*†	1/2" Conduit / Flying Leads 24"			12
H49†	1/2" Conduit / Flying Leads 24"			24
H53†	1/2" Conduit / Flying Leads 24"	120	110	

* Mobile Voltage Rated.

† Inline Version Only.

Notes:

Inline Valves

Conduit Inline valves cannot be mounted to IEM or Subbase Manifolds.



How to Order Manifold Assemblies

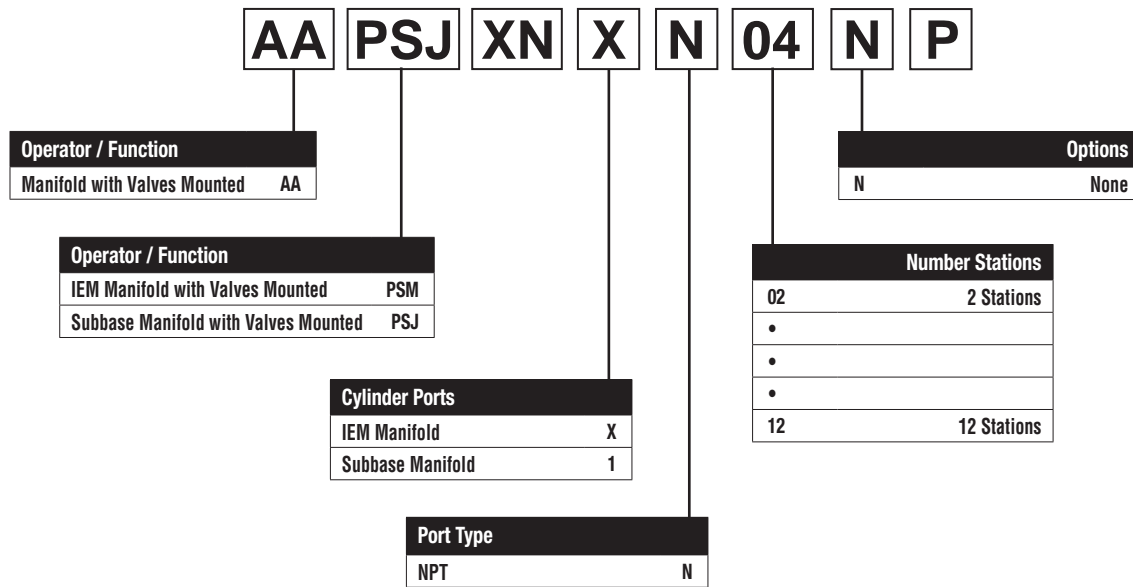

IEM Bar Manifold Assembly

First line item describes IEM Assembly. Subsequent line items listed identify each station in the Manifold starting with Station Number 1.

Ordering Example

Item	Qty	Part Number
001	1	AAPSMXNXN04NP
002	2	XM30NBG49A - Station 1, 2 - Normally Closed
003	1	XM40NBG49A - Station 3
004	1	XM40NBG49FOA - Station 4

Notes: When ordering Add-A-Folds, list valves left to right when looking at the Port 1/3 side of the manifold. All 3-Way valves will be assembled as 3-Way N.C. valves.

Component Ordering Example

Item	Qty	Part Number
001	1	PSMXNXN04NP (IEM Kit)
002	2	XM30NBG49A (Valve)
003	1	XM40NBG49A (Valve)
004	1	XM40NBG49FOA (Valve)

Subbase Manifold Assembly

First line item describes Subbase Assembly. Subsequent line items listed identify each station in the Manifold starting with Station Number 1.

Ordering Example

Item	Qty	Part Number
001	1	AAPSJXN1N04NP
002	2	XM3VNBG49A - Station 1, 2 - Normally Closed
003	1	XM4VNBG49A - Station 3
004	1	XM4VNBG49FOA - Station 4

Notes: When ordering Add-A-Folds, list valves left to right when looking at the Port 2/4 side of the manifold. All 3-Way valves will be assembled as 3-Way N.C. valves. Isolator Discs are required for N.O. functions.

Component Ordering Example

Item	Qty	Part Number
001	1	PSXM31010P (End Plate Kit)
002	4	PSXM530CP (Subbase Kit)
003	2	XM3VNBG49A (Valve)
004	1	XM4VNBG49A (Valve)
005	1	XM4VNBG49FOA (Valve)

B

Direct Acting Valves

XM Series

15mm Solenoid Valves



For inventory, lead time, and kit lookup, visit www.pdnplu.com

Accessories

Manifold



Description	Part number
IEM bar manifold (NPT)	PSMXNXN##NP

- stations 02 to 12 (04 Shown)

Subbase



Description	Part number
Manifold subbase kit (NPT)	PSXM530CP

Plug-in Electrical Connectors - 9.4mm



Description	Indication	Voltage	Part number
Unwired Plug	None	N/A	PESC10
	LED & Suppression	12/24V	PESC2020B
		120VAC	PESC2001F



Plug with 6" lead	None	N/A	P8L-C2
	LED & Suppression	12/24V	PESC2220B
		120VAC	P8LC221E

IEM Bar Manifold Assembly

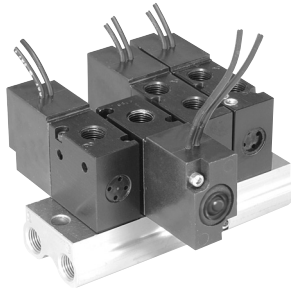

IEM Bar Manifold allows for mounting of 3-Way and 4-Way Inline valves on the same manifold. 3-Way Valves can be mounted on the same manifold to provide a Normally Closed or Normally Open function by rotating the valves 180°. 4-Way valves can be mounted with or without Flow Controls.

IEM Bar Manifold Assemblies consist of valves and an IEM Manifold. Valves and IEM Manifold can be ordered separately.

**Direct Acting Valve Products
XM Valve Series**

Accessories



Description	Part number
End plate kit (NPT)	PSXM31010P



Description	Part number
Blanking plate kit	PSXM8310P
Subbase Kit includes: (1) Plate, (3) Screws, (4) Gaskets	
Fits subbase or IEM type manifold.	



Mounting Bracket - Inline valve	PSXM8288P
---------------------------------	------------------



Isolator plugs - Subbase manifold	PSXM40900P
-----------------------------------	-------------------



IEM valve / manifold o-ring kit	PSXM2186P
---------------------------------	------------------



Subbase valve / manifold bolt kit	PSXM8100P
-----------------------------------	------------------

Subbase Manifold Assembly



Subbase Manifold allows for mounting of 3-Way and 4-Way Subbase Valves can be mounted on the same manifold. 3-Way Valves can be mounted on the same manifold to provide a Normally Closed or Normally Open function through the use of port isolation kits. 4-Way valves can be mounted with or without Flow Controls.

Subbase Manifold Assemblies consist of Valves, End Plate Kit and Manifold Subbase Kits. Valves, End Plate Kit and Manifold Subbase Kits can be ordered separately.

B

Direct Acting Valves

XM Series

15mm Solenoid Valves



Inline Valve on IEM Bar Manifold Assembly

IEM Bar Manifold Assembly's are assembled by adding Inline Valves to an IEM Bar Manifold. O-rings are installed at each valve station in the counterbore on the top of the manifold. Valves are installed with 2 mounting screws. For 3-Way N.C. valve operation, line up the solenoid end of the Valve with Port 1 on the Manifold. For 3-Way N.O. operation, line up the solenoid end of the valve with Port 3 on the manifold. For 4-Way valve operation, line up the Solenoid end of the valve with Port 1 on the manifold. If manifolds are factory assembled, all 3-Way valves are N.C. To convert from N.C. to N.O. operation, remove valve from the base and place valve 180° from the original position with the solenoid end lined up with the 3-Port on the manifold.

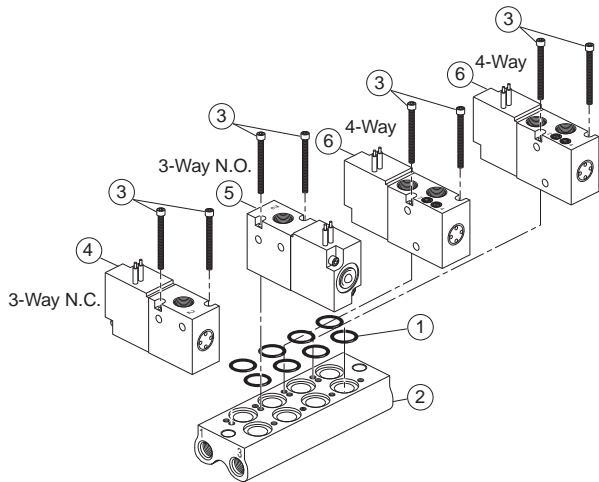

Subbase Valve and Manifold Assembly

Subbase Manifold Assembly's are assembled by adding tie rods and manifold bases to the end plate kit of the subbase end plate kit as shown below. Valves are added to each subbase per manifold design. 4-Way and 3-Way valves are mounted with Solenoids Coils facing away from subbase delivery ports 2 and 4. For 3-Way N.O. Functions, valves must be isolated from the other 3-Way N.C. and 4-Way valves on the manifold. This is achieved by placing port isolator discs in between the subbase of the first 3-Way N.O. Valve and the subbase of the last 3-Way N.C. or 4-Way valve in the Subbase Manifold. Inlet pressure is connected to Port 3 of the manifold for the 3-Way N.O. valves. Inlet pressure is connected to the Port 1 of the manifold for the 3-Way N.C. and 4-Way valves. Separate Inlet Pressure Ports and Exhaust Ports are required for N.O. and N.C. 3-way function valves.

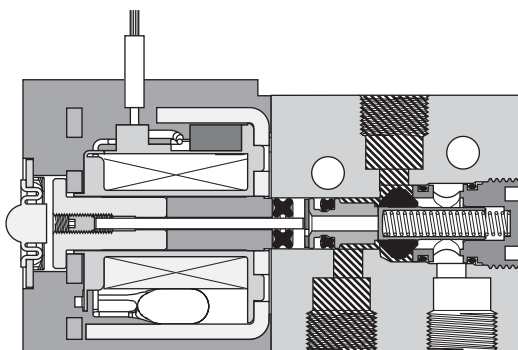
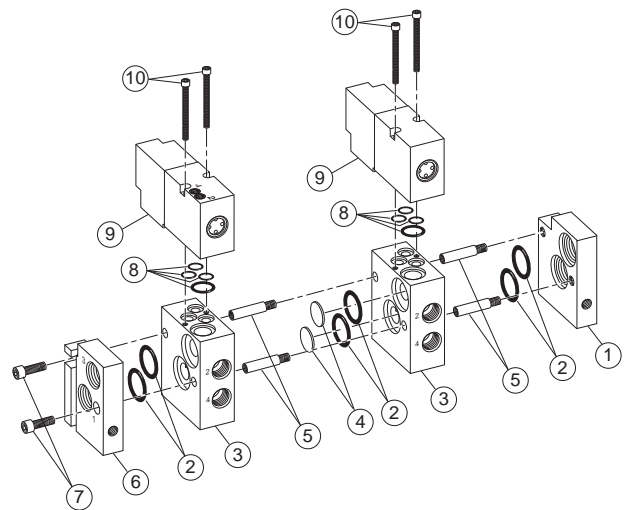

3-Way Inline Valve
 Shown Energized

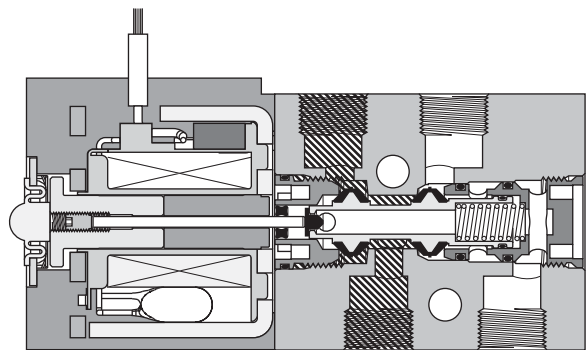

4-Way Inline Valve
 Shown De-Energized

Pressure Exhaust



For inventory, lead time, and kit lookup, visit www.pdnplu.com

XM 3-way Inline

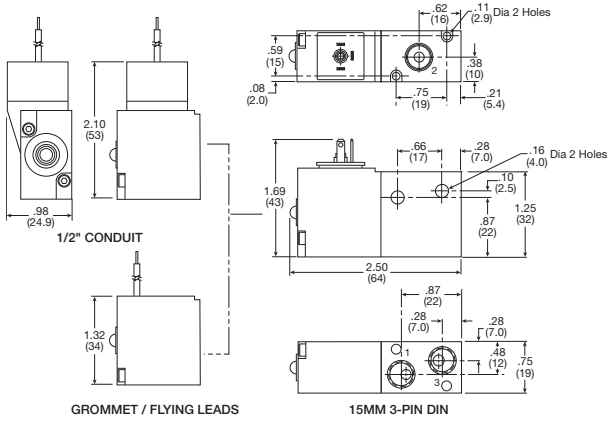

Inches (mm)
 Note: 22 AWG black cross linked polyethylene insulated lead wire.

XM 4-way Inline

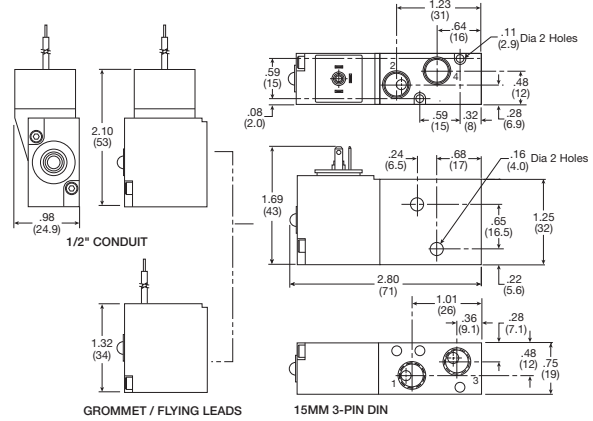

Inches (mm)
 Note: 22 AWG black cross linked polyethylene insulated lead wire.

XM 4-way Inline with Flow Controls

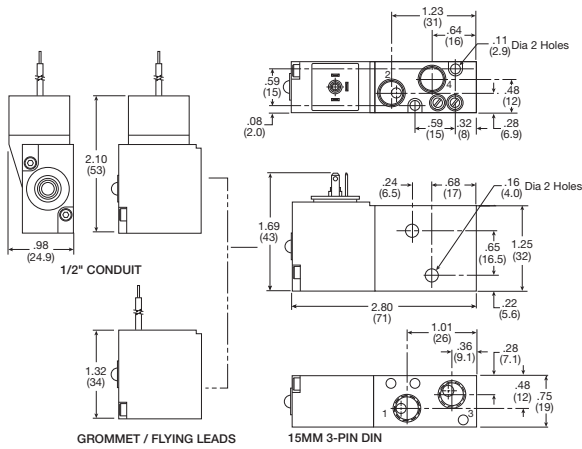

Inches (mm)
 Note: 22 AWG black cross linked polyethylene insulated lead wire.

XM IEM Manifold

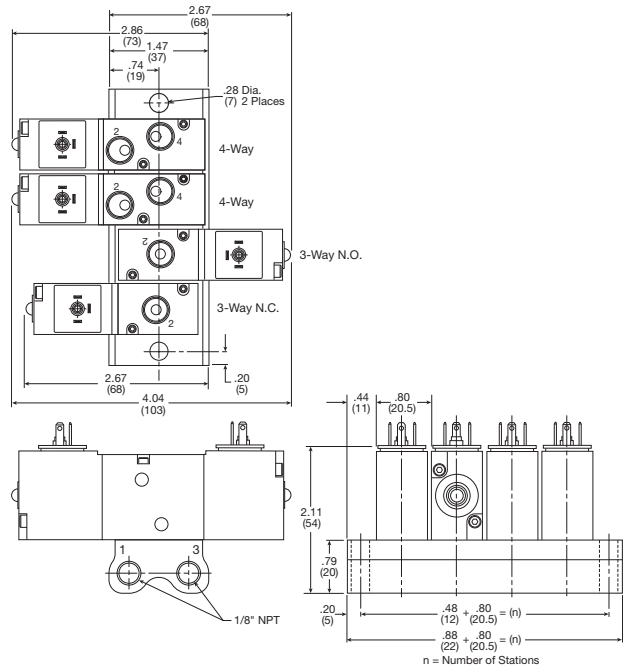

XM IEM Subbase

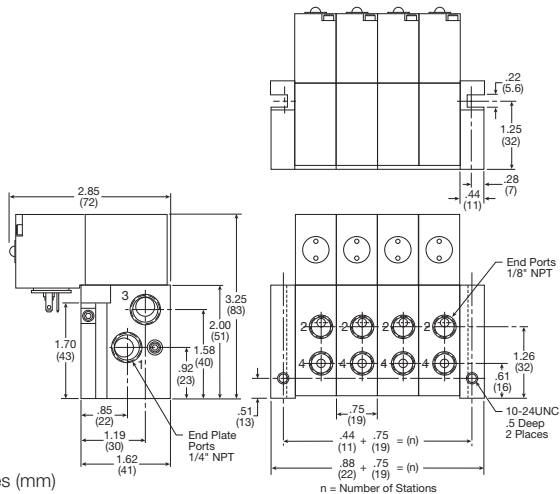

Inches (mm)

Mounting Bracket Dimensions

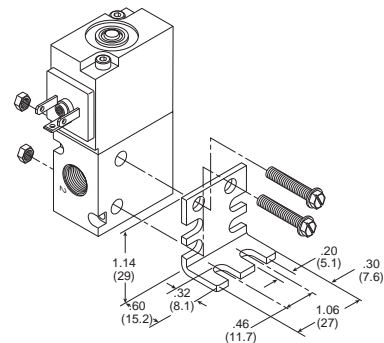

15mm Solenoid Valve

A compact 15mm, 3-way subbase or manifold mounted valve. Ideally suited for use in stationary or mobile equipment applications, where flow rates and low temperatures are a key consideration.

Features

- Compact and simple design
- Utilizes 15mm solenoid operators
- Manifold allows mounting of normally open and normally closed operators simultaneously
- Up to 20 stations available

Solenoids

- 15mm low watt solenoids are UL certified and approved to be CE marked
- Wide range of voltages available

Applications

- Piloting for process control valves
 - pharmaceutical equipment
 - waste water treatment systems
 - food processing
 - chemical batching
- Industrial laundry equipment
- Paint spray & dyeing equipment
- Textile winding applications
- Vacuum and conveyor applications

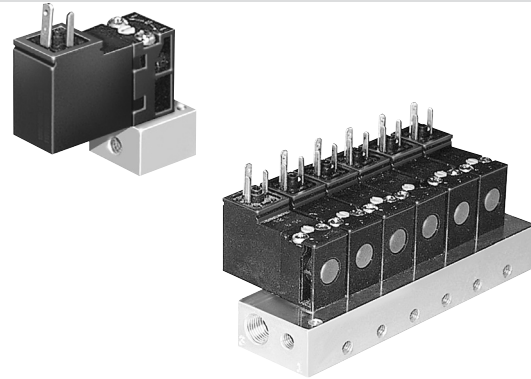

Operating information

Operating pressure:	Vacuum to 145 PSIG (Vacuum to 10 bar)
Operating temperature:	
Standard Flow:	5°F to 140°F (-15°C to 60°C)
High Flow:	5°F to 122°F (-15°C to 50°C)
Mobile Applications (47 & 48 Voltage Options):	-40°F to 158°F (-40°C to 70°C)
Storage temperature:	
All applications:	-40°F to 158°F (-40°C to 70°C)

Material specifications

Body	Glass filled polyamide
Internal metal parts	Steel
Screws	Steel
Bottom plug	Thermoplastic
Poppet seals	Nitrile for standard, fluorocarbon for mobile

Technical data

Electrical interface per:	DIN 43650 Form C (EN175301-803C) 8mm pin spacing
Pneumatic interface per:	AFNOR E 0652 110 N
Protection:	IP65 (Washdown)
Air flow:	Standard flow 0.033 Cv (33 Lpm) (1.2W) (1.6VA)
Voltage tolerance:	All voltages except 47 & 48: Rated voltage +10% / -15% options 47 & 48: Rated voltage +25% / -30%

Manifold - Pins Down

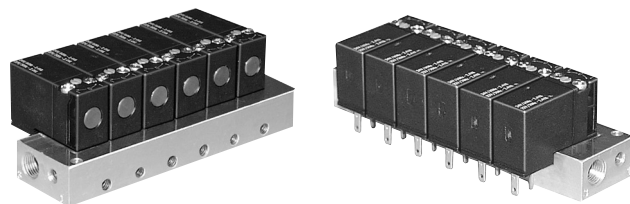

Manifold - Pins Up

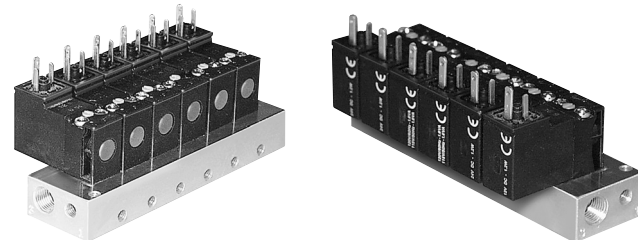

B

Direct Acting Valves

XM Series

15mm Solenoid Valves



For inventory, lead time, and kit lookup, visit www.pdnplu.com

Ordering Information

15mm Solenoid Kit Information

3/2 Normally Non-passing (NNP) /
Normally Closed (NC) Valves

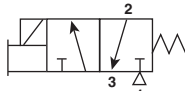

3/2 Normally Passing (NP) /
Normally Open (NO) Valves

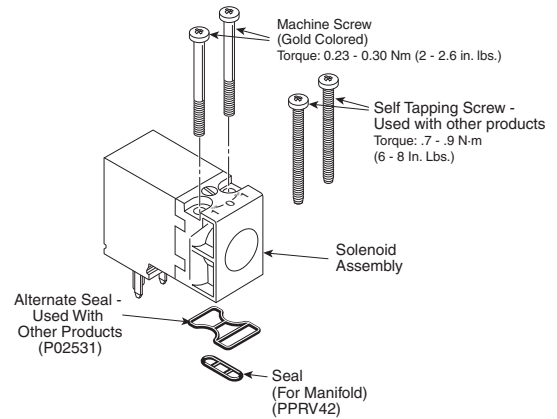
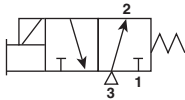

NC (NNP) Solenoids / Kits

	## Voltage (S = Standard, O = Optional, — = N/A)					Kit No.
	42 (24VAC)	45 (12VDC)	49 (24VDC)	53 (120VAC)	57 (230VAC)	
* Override						
B (Non-lock, Flush)	O	O	S	S	O	PS2982*##P Pins: UP NC / NNP 1.2W / 1.6VA
C (Lock, Flush)	O	O	S	S	O	
D (Non-lock, Ext)	—	—	O	O	—	
B (Non-lock, Flush)	O	O	S	S	—	PS3541*##P Pins: DOWN NC / NNP 1.8W / 2.4VA
C (Lock, Flush)	O	O	S	S	—	
D (Non-lock, Ext)	—	—	O	O	—	
E (Lock, Ext)	—	—	O	O	—	
B (Non-lock, Flush)	O	O	O	O	O	PS3441*##P Pins: DOWN NC / NNP 1.2W / 1.6VA
C (Lock, Flush)	O	O	O	O	O	
B (Non-lock, Flush)	—	O	S	S	—	PS3202*##P Pins: UP NO / NP 1.2W / 1.6VA

* Override, ## Voltage

Female Electrical Connectors

15mm 3-Pin DIN 43650C (Use with enclosure "5")

Description		Connector	Connector with cord
Unlighted	18 Inches	PS2932BP	PS2932HBP
Unlighted	6 Feet	PS2932BP	PS2932JBP
Light – 12VAC or DC	6 Feet	PS294675BP	PS2946J75BP*
Light – 24VAC or DC	6 Feet	PS294679BP	PS2946J79BP*
Light – 110/120VAC	6 Feet	PS294683BP	PS2946J83BP*
Light – 240/230VAC		PS294687BP	N/A

* LED with surge suppression.

Note: Max ø6.5mm cable size required for connector w/o 6' (2m) cord.
IP65 rated when properly installed.

Engineering Data:

- Conductors: 2 poles plus ground
- Cable range (Connector only): 4 to 6mm (0.16 to 0.24 Inch)
- Contact spacing: 8mm

Most popular.

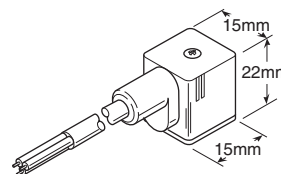

Connector with cord

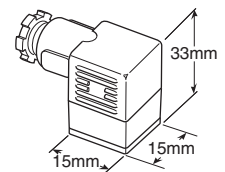

Connector only



For inventory, lead times, and kit lookup, visit www.pdnplu.com

Model Number Index

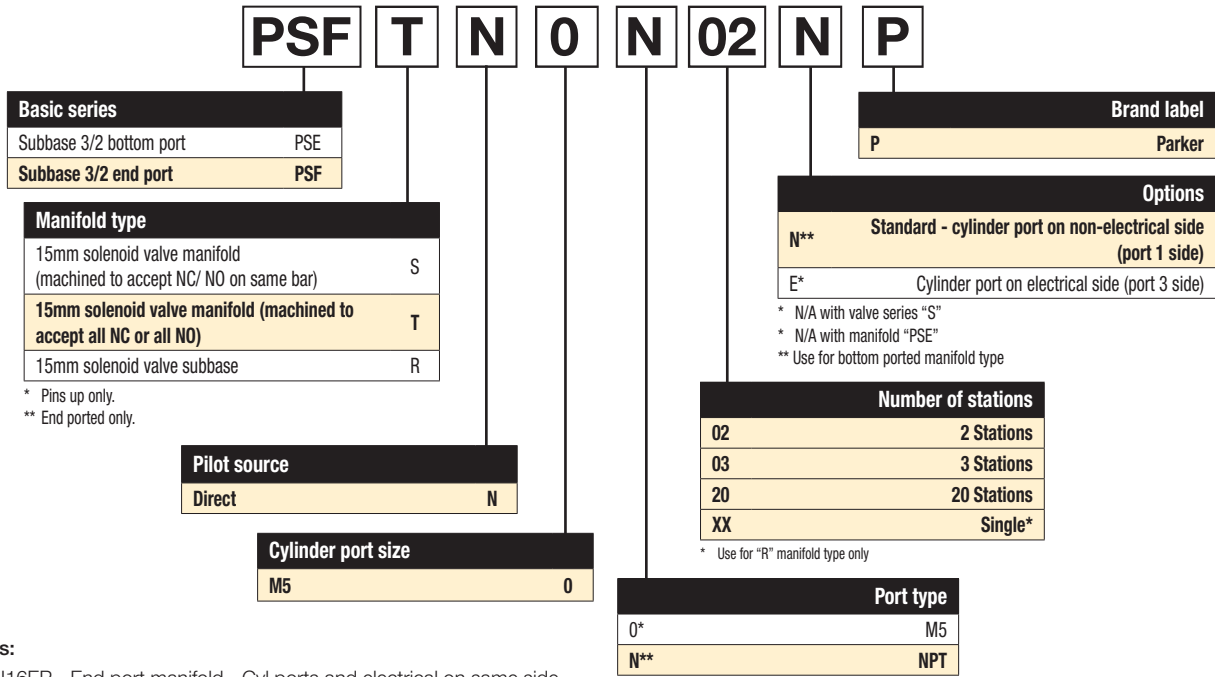

Examples:

PSFTNON16EP - End port manifold - Cyl ports and electrical on same side
 PSESNON10NP - Bottom port manifold - N/C and N/O can be interchanged
 PSFTNON10NP - End port manifold - Cyl ports and electrical are opposite

Manifold Dimensions

Special mounting considerations must be made for connector assembly clearance when mounting solenoid valves with pins down.

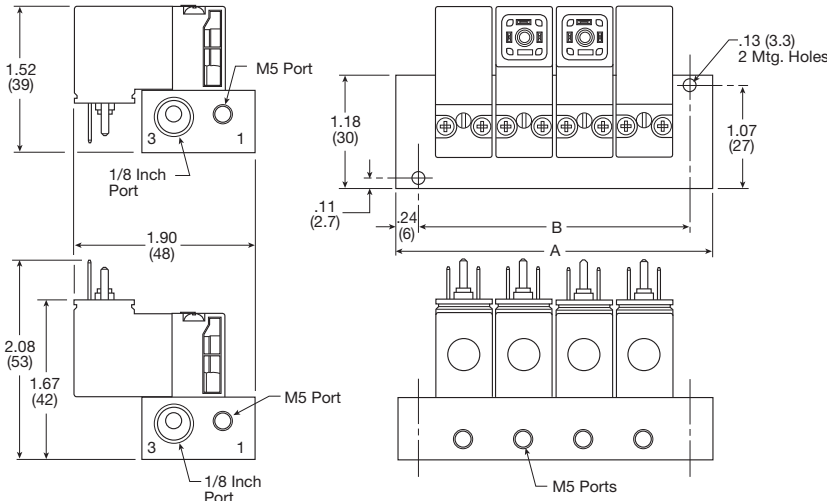

Number of stations	Dim. A	Dim. B
2	2.04 (52)	1.57 (40)
3	2.68 (68)	2.20 (56)
4	3.31 (84)	2.83 (72)
5	3.94 (100)	3.46 (88)
6	4.57 (116)	4.09 (104)
7	5.20 (132)	4.72 (120)
8	5.83 (148)	5.35 (136)
9	6.46 (164)	5.98 (152)
10	7.09 (180)	6.61 (168)
11	7.72 (196)	7.24 (184)
12	8.35 (212)	7.87 (200)
13	8.98 (228)	8.50 (216)
14	9.61 (244)	9.13 (232)
15	10.23 (260)	9.76 (248)
16	10.87 (276)	10.39 (264)
17	11.50 (292)	11.02 (280)
18	12.13 (308)	11.65 (296)
19	12.76 (324)	12.28 (312)
20	13.39 (340)	12.91 (328)

Subbase Dimensions

Pins up only.

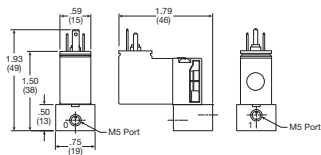

15mm Solenoid Dimensions

Pins up only.

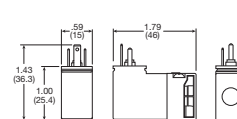

Most popular.



For inventory, lead time, and kit lookup, visit www.pdnplu.com

B11

Parker Hannifin Corporation
 Pneumatic Division
 Richland, Michigan
www.parker.com/pneumatics

B

Direct Acting Valves

XM Series

15mm Solenoid Valves

B

Direct Acting Valves

XM
Series

15mm Solenoid
Valves



For inventory, lead times, and kit lookup, visit www.pdnplu.com

B12

Parker Hannifin Corporation
Pneumatic Division
Richland, Michigan
www.parker.com/pneumatics

Pneumatic Valve Products

Inline Valve Series

Viking Lite Series

Features	C2
Common Part Numbers / Ordering Information	C3-C5
Accessories	C6
Dimensional Data	C7-C10

Viking Xtreme Series

Features	C11
Common Part Numbers / Ordering Information	C12-C19
Accessories	C20-C23, C28-C30
Technical Data	C24-C27, C31
Dimensional Data	C32-C40

B Series

Features	C41
Common Part Numbers / Ordering Information	C42-C48
Accessories	C49-C52, C54
Technical Data	C53, C55-C60
Dimensional Data	C61-C73

Air Saver Series

Features	C74-C75
Specifications	C76
Ordering Information / Dimensional Data	C77-C82

ADEX Series

Features	C83
Common Part Numbers / Ordering Information	C84
Accessories	C85-C89
Technical Data	C90-C91
Dimensional Data	C92-C95

N Series

Features	C96
Common Part Numbers / Ordering Information	C97-C100
Technical Data	C101-C106
Dimensional Data	C107-C113

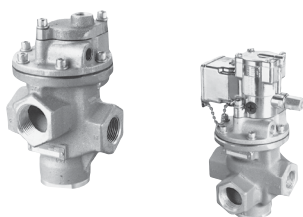
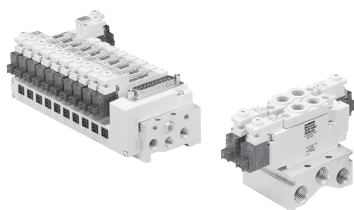
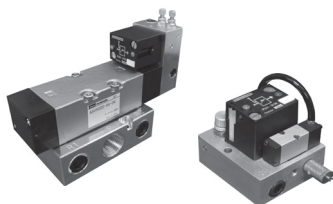
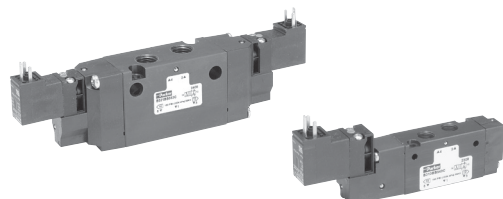
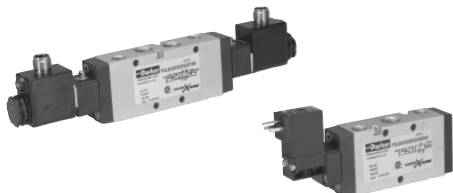
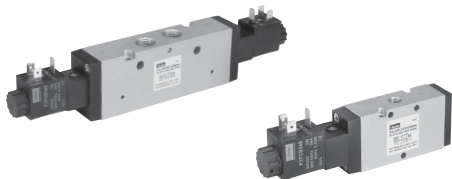

C

Inline Valves

Viking Lite Series

The Viking Lite valve range is robust, versatile and combines a large flow capacity with short change-over times, designer may choose 1/8, 1/4 or 3/8 port sizes along with 24VDC and 120VAC voltage options. Viking Lite valves are fitted with dynamic bi-directional spool seals suitable for pressures up to 10 bar and ambient temperatures between -10°C to + 50°C. When in service, radial expansion of the spool seal occurs to maintain sealing contact with the valve bore. This sealing method reduces friction and produces a lower required pilot pressure. Valves do not require lubrication in operation but they can also be installed in systems that are lubricated.

Ports

- P2LAZ: 1/8 inch NPT & BSPP, Cv = 0.6
- P2LBZ: 1/4 inch NPT & BSPP, Cv = 1.5
- P2LCZ: 3/8 inch NPT & BSPP, Cv = 2.5

Mounting

- Inline
- IEM aluminum bar

Solenoids

2.5 watts
- 22mm, 3-pin (DIN 43650)
24VDC and 120VAC

• Certification / approval

- IP65 Rated, RoHS, CE

Materials

Valve body	Anodized aluminium
End covers	Anodized aluminium
Spool	Aluminium
Piston	Acetal plastic / Anodized aluminium
End cover seals	Nitrile rubber
End cover screws	Zinc plated steel
Springs	Stainless steel
Mounting screws for solenoid	Stainless steel
Spool seals	Nitrile

Features

WCS

- Maximum Performance
 - Low friction - fast response - less wear
- Long Cycle Life
 - Under pressure, radial expansion of the seal occurs to maintain sealing contact with the valve bore
- Non-Lube Service
 - No lubrication required for continuous valve shifting
- Bi-Directional Spool Seals
 - Common spool used for any pressure

- Solenoid operated, IP65, RoHS, CE
- 90° rotation

The bore is polished to a very high surface finish for maximum flow capacity and long life.

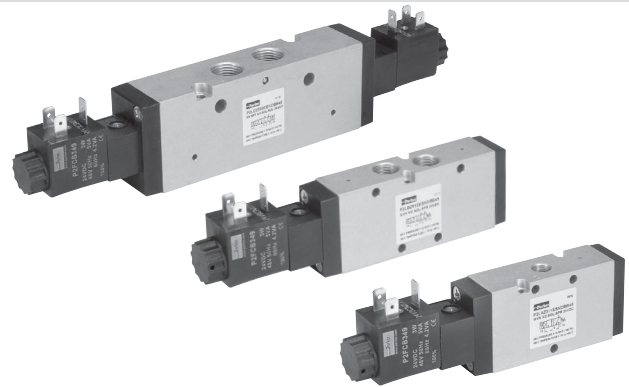
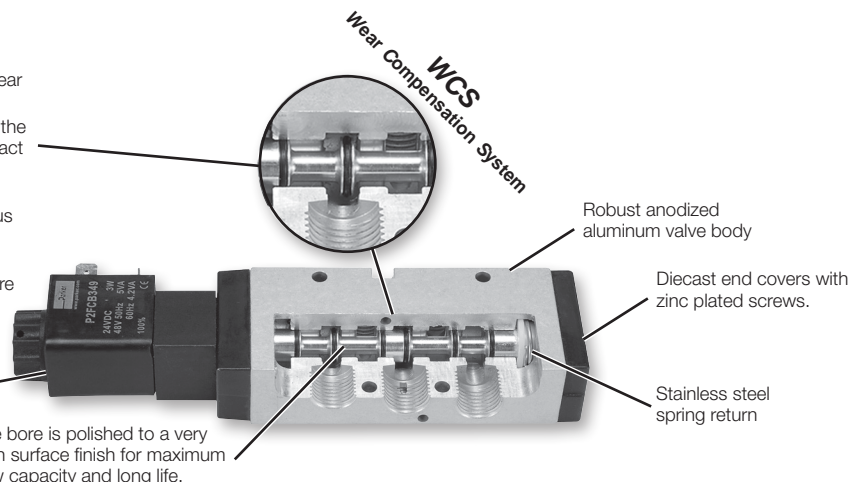

Operating information

Operating pressure: 145 PSIG (10 bar)
Minimum: See chart
Operating temperature: 14°F to 122°F (-10°C to 50°C)

Minimum operating pressure, PSIG (bar)

Valve type - Internal pilot	P2LAZ	P2LBZ	P2LCZ
Single solenoid - spring return	43.5 (3.0)	43.5 (3.0)	43.5 (3.0)
Single remote pilot - spring return	43.5 (3.0)	43.5 (3.0)	43.5 (3.0)
Double solenoid - 2-position	22 (1.5)	22 (1.5)	22 (1.5)
Double remote pilot - 2-position	22 (1.5)	22 (1.5)	22 (1.5)
Double solenoid - 3-position (APB, PC, CE)	43.5 (3.0)	43.5 (3.0)	43.5 (3.0)
Double remote pilot - 3-position (APB, PC, CE)	43.5 (3.0)	43.5 (3.0)	43.5 (3.0)

Recommended air quality for valves

For best possible service life and trouble free operation, ISO 8573-1 quality class 3.4.3 should be used. This means 5µm filter (standard filter) dew point +3°C for indoor operation (a lower dew point should be selected for outdoor operation) and oil concentration 1.0 mg oil/m³, which is what a standard compressor with a standard filter gives.

Common Part Numbers

3/2 - 2-Position Single Solenoid, Non-locking Manual Override

Port size	Cv	Response time (msec)	Weight lb (kg)	Voltage	Part number	
					(NPT)	(BSPP)
1/8	0.6	15 / 35	0.35 (0.16)	24VDC	P2LAZ391ESNDBB49	P2LAZ311ESNDBB49
				120VAC	P2LAZ391ESNDBB53	P2LAZ311ESNDBB53
1/4	1.5	18 / 45	0.35 (0.16)	24VDC	P2LBZ392ESNDBB49	P2LBZ312ESNDBB49
				120VAC	P2LBZ392ESNDBB53	P2LBZ312ESNDBB53
3/8	2.5	27 / 45	0.77 (0.35)	24VDC	P2LCZ393ESNDBB49	P2LCZ313ESNDBB49
				120VAC	P2LCZ393ESNDBB53	P2LCZ313ESNDBB53

P2LAZ Shown

3/2 - 2-Position Double Solenoid, Non-locking Manual Override

Port size	Cv	Response time (msec)	Weight lb (kg)	Voltage	Part number	
					(NPT)	(BSPP)
1/8	0.6	10 / 10	0.40 (0.18)	24VDC	P2LAZ391EENDBB49	P2LAZ311EENDBB49
				120VAC	P2LAZ391EENDBB53	P2LAZ311EENDBB53
1/4	1.5	12 / 12	0.40 (0.18)	24VDC	P2LBZ392EENDBB49	P2LBZ312EENDBB49
				120VAC	P2LBZ392EENDBB53	P2LBZ312EENDBB53
3/8	2.5	17 / 17	0.80 (0.36)	24VDC	P2LCZ393EENDBB49	P2LCZ313EENDBB49
				120VAC	P2LCZ393EENDBB53	P2LCZ313EENDBB53

P2LAZ Shown

5/2 - 2-Position Single Solenoid, Non-locking Manual Override

Port size	Cv	Response time (msec)	Weight lb (kg)	Voltage	Part number	
					(NPT)	(BSPP)
1/8	0.6	15 / 35	.037 (0.17)	24VDC	P2LAZ591ESNDBB49	P2LAZ511ESNDBB49
				120VAC	P2LAZ591ESNDBB53	P2LAZ511ESNDBB53
1/4	1.5	18 / 45	0.44 (0.20)	24VDC	P2LBZ592ESNDBB49	P2LBZ512ESNDBB49
				120VAC	P2LBZ592ESNDBB53	P2LBZ512ESNDBB53
3/8	2.5	27 / 45	0.95 (0.43)	24VDC	P2LCZ593ESNDBB49	P2LCZ513ESNDBB49
				120VAC	P2LCZ593ESNDBB53	P2LCZ513ESNDBB53

P2LAZ Shown

5/2 - 2-Position Double Solenoid, Non-locking Manual Override

Port size	Cv	Response time (msec)	Weight lb (kg)	Voltage	Part number	
					(NPT)	(BSPP)
1/8	0.6	10 / 10	.042 (0.19)	24VDC	P2LAZ591EENDBB49	P2LAZ511EENDBB49
				120VAC	P2LAZ591EENDBB53	P2LAZ511EENDBB53
1/4	1.5	12 / 12	0.46 (0.21)	24VDC	P2LBZ592EENDBB49	P2LBZ512EENDBB49
				120VAC	P2LBZ592EENDBB53	P2LBZ512EENDBB53
3/8	2.5	17 / 17	0.97 (0.44)	24VDC	P2LCZ593EENDBB49	P2LCZ513EENDBB49
				120VAC	P2LCZ593EENDBB53	P2LCZ513EENDBB53

P2LAZ Shown

5/3 - 3-Position, All Ports Blocked, Non-locking Manual Override

Port size	Cv	Response time (msec)	Weight lb (kg)	Voltage	Part number	
					(NPT)	(BSPP)
1/8	0.6	18 / 40	0.57 (0.26)	24VDC	P2LAZ691EENDBB49	P2LAZ611EENDBB49
				120VAC	P2LAZ691EENDBB53	P2LAZ611EENDBB53
1/4	1.5	22 / 55	0.62 (0.28)	24VDC	P2LBZ692EENDBB49	P2LBZ612EENDBB49
				120VAC	P2LBZ692EENDBB53	P2LBZ612EENDBB53
3/8	2.5	30 / 90	1.32 (0.60)	24VDC	P2LCZ693EENDBB49	P2LCZ613EENDBB49
				120VAC	P2LCZ693EENDBB53	P2LCZ613EENDBB53

P2LAZ Shown

Most popular. Notes: Response time: Actuate to 90% pressure / return to exhaust to 10% of supply pressure. 93 PSIG (6.3 bar) / temperature 68°F (20°C)



For inventory, lead time, and kit lookup, visit www.pdnplu.com

5/3 - 3-Position, Pressure Center, Non-locking Manual Override

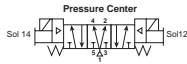

P2LAZ Shown

Port size	Cv	Response time (msec)	Weight lb (kg)	Voltage	Part number (NPT)	Part number (BSPP)
1/8	0.6	18 / 40	0.57 (0.26)	24VDC	P2LAZ791EENDBB49	P2LAZ711EENDBB49
				120VAC	P2LAZ791EENDBB53	P2LAZ711EENDBB53
1/4	1.5	22 / 55	0.62 (0.28)	24VDC	P2LBZ792EENDBB49	P2LBZ712EENDBB49
				120VAC	P2LBZ792EENDBB53	P2LBZ712EENDBB53
3/8	2.5	30 / 90	1.32 (0.60)	24VDC	P2LCZ793EENDBB49	P2LCZ713EENDBB49
				120VAC	P2LCZ793EENDCB53	P2LCZ713EENDBB53

5/3 - 3-Position, Center Exhaust

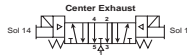

P2LAZ Shown

Port size	Cv	Response time (msec)	Weight lb (kg)	Voltage	Part number (NPT)	Part number (BSPP)
1/8	0.6	18 / 40	0.57 (0.26)	24VDC	P2LAZ891EENDBB49	P2LAZ811EENDBB49
				120VAC	P2LAZ891EENDBB53	P2LAZ811EENDBB53
1/4	1.5	22 / 55	0.62 (0.28)	24VDC	P2LBZ892EENDBB49	P2LBZ812EENDBB49
				120VAC	P2LBZ892EENDBB53	P2LBZ812EENDBB53
3/8	2.5	30 / 90	1.32 (0.60)	24VDC	P2LCZ893EENDBB49	P2LCZ813EENDBB49
				120VAC	P2LCZ893EENDBB53	P2LCZ813EENDBB53

Notes: Response time: Actuate to 90% pressure / return to exhaust to 10% of supply pressure. 93 PSIG (6.3 bar) / temperature 68°F (20°C)

Viking Lite Single & Double Solenoid Operated Valves

P2L A Z 5 91 ES N D C B 49

Valve size

1/8"	A
1/4"	B
3/8"	C

Series

Viking Lite	Z
-------------	---

Valve type / function

Internal pilot supply to solenoid	
3/2 NC - 2-position	3
5/2 2-position	5
5/3 3-position, APB	6
5/3 3-position, PC	7
5/3 3-position, CE	8

Voltage / frequency

49	24VDC
53	120VAC
Blank	Valve less coil

Enclosures / lead length

B	22mm rectangular 3-pin - type B industrial (male only)
N	Valve less coil

Overrides

C	Extended - locking
B	Flush - non-locking

Solenoid pilot type

D	Pilot exhaust vented
---	----------------------

Main port thread

G1/8 (P2LA)	11
G1/4 (P2LB)	12
G3/8 (P2LC)	13
1/8" NPT (P2LA)	91
1/4" NPT (P2LB)	92
3/8" NPT (P2LC)	93

Valve type

N	14°F to 122°F (-10°C to 50°C)
---	-------------------------------

12 End operator

EE	Double solenoid
ES*	Single solenoid, spring return

* Not available with 3-position valves.

Most popular.



For inventory, lead times, and kit lookup, visit www.pdnplu.com

Part Numbers / Ordering Information

Single Remote Air Pilot, 3-way, 2-position

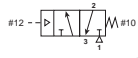

P2LBZ Shown

Port size (NPT)	Cv	Response time (msec)	Weight lb (kg)	Valve type	Part number
1/8"	0.7	15 / 45	0.25 (0.11)	P2LAX	P2LAZ391PS
1/4"	1.3	25 / 65	0.25 (0.11)	P2LBX	P2LBZ392PS
3/8"	2.5	25 / 65	0.67 (0.30)	P2LCX	P2LCZ393PS

Single Remote Air Pilot, 4-way, 2-position

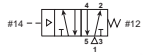

P2LBZ Shown

Port size (NPT)	Cv	Response time (msec)	Weight lb (kg)	Valve type	Part number
1/8"	0.7	15 / 45	0.27 (0.12)	P2LAX	P2LAZ591PS
1/4"	1.3	20 / 55	0.27 (0.12)	P2LBX	P2LBZ592PS
3/8"	2.5	25 / 85	0.85 (0.35)	P2LCX	P2LCZ593PS

Double Remote Air Pilot, 4-way, 2-position

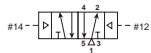

P2LBZ Shown

Port size (NPT)	Cv	Response time (msec)	Weight lb (kg)	Valve type	Part number
1/8"	0.7	11 / 11	0.22 (0.10)	P2LAX	P2LAZ591PP
1/4"	1.3	13 / 13	0.26 (0.12)	P2LBX	P2LBZ592PP
3/8"	2.5	18 / 18	0.77 (0.35)	P2LCX	P2LCZ593PP

Notes: Response time: Actuate to 90% pressure / return to exhaust to 10% of supply pressure. 93 PSIG (6.3 bar) / temperature 68°F (20°C).

Viking Lite Remote Air Pilot Operated Valves

P2LAZ591PS

Valve size	
1/8"	A
1/4"	B
3/8"	C

Operators / return	
PP	Double remote pilot, 5/32" (4mm) tube
PS*	Single remote pilot, spring return, 5/32" (4mm) tube

* Not available with 3-position valves.

Valve type / function	
<i>Internal pilot supply to solenoid</i>	
3/2 NC - 2-position	3
5/2 2-position	5
5/3 3-position, APB	6
5/3 3-position, PC	7
5/3 3-position, CE	8

Main port thread	
11	G1/8 (P2LA)
12	G1/4 (P2LB)
13	G3/8 (P2LC)
91	1/8" NPT (P2LA)
92	1/4" NPT (P2LB)
93	3/8" NPT (P2LC)

 Most popular.



For inventory, lead time, and kit lookup, visit www.pdnplu.com

Accessories

IEM Bar Manifold, Inline Valve Only*



Valve series	Valve function	# of Stations	Weight lb (kg)	Manifold only (NPT)	Manifold only (BSPP)
P2LAZ / P2LBZ	3-way	2	0.84 (0.38)	91213202SXZN	91213202SXZ
P2LAZ / P2LBZ	3-way	4	1.41 (0.64)	91213204SXZN	91213204SXZ
P2LAZ / P2LBZ	3-way	6	1.96 (0.89)	91213206SXZN	91213206SXZ
P2LAZ / P2LBZ	3-way	8	2.54 (1.15)	91213208SXZN	91213208SXZ
P2LAZ / P2LBZ	3-way	10	3.09 (1.40)	91213210SXZN	91213210SXZ

Kits include: Manifold, valve hold down bolts, gaskets.



Valve series	Valve function	# of Stations	Weight lb (kg)	Manifold only (NPT)	Manifold only (BSPP)
P2LAZ	4-way	2	0.68 (0.31)	9121658068N	9121658068
P2LAZ	4-way	4	1.06 (0.48)	9121658075N	9121658075
P2LAZ	4-way	6	1.39 (0.63)	9121658076N	9121658076
P2LAZ	4-way	8	1.76 (0.80)	9121658077N	9121658077
P2LAZ	4-way	10	2.16 (0.98)	9121658078N	9121658078

Kits include: Manifold, valve hold down bolts, gaskets.



Valve series	Valve function	# of Stations	Weight lb (kg)	Manifold only (NPT)	Manifold only (BSPP)
P2LBZ	4-way	2	1.53 (0.69)	9121594805XN	9121594805X
P2LBZ	4-way	4	2.49 (1.13)	9121594806XN	9121594806X
P2LBZ	4-way	6	3.44 (1.56)	9121594807XN	9121594807X
P2LBZ	4-way	8	4.41 (2.00)	9121594808XN	9121594808X
P2LBZ	4-way	10	5.40 (2.45)	9121594812XN	9121594812X

Kits include: Manifold, valve hold down bolts, gaskets.

* For odd number of stations, consider Viking Xtreme bar manifold.

IEM Bar Manifold, Inline Valve Only



Valve series	Valve function	# of Stations	Manifold only (NPT & BSPP)
P2LCZ	4-way		Use Viking Xtreme IEM bar manifold

Note: Only 4-way Viking Lite will mount on Viking Xtreme manifold. If 3-way desired, use 4-way and plug part #2 for N.C. valve function.

Manifold Accessories / Parts



Valve series	Description	Weight lb (kg)	Kit number
P2LAZ / P2LBZ *	3-way: Blanking kit with mounting screws (2)	0.22 (0.10)	912132BPSXZ
P2LAZ *	4-way: Blanking kit with mounting screws (2)	0.11 (0.05)	9121658063
P2LBZ *	4-way: Blanking kit with mounting screws (2)	0.04 (0.02)	9121594809X

*Note: O-ring for blanking kit included with manifold. For replacement o-rings or fastener bolts, use Viking Xtreme Kits.

22mm Rectangular 3-Pin – Type B Industrial
(Use with Enclosure “B”)

Description	Connector with 6' (2m) cord	Connector
Unlighted	PS2429JBP	PS2429BP
Light – 24VDC	PS2430J79BP*	PS243079BP
Light – 120V/60Hz	PS2430J83BP*	PS243083BP

* LED with surge suppression.

Note: Max ø6.5mm cable size required for connector w/o 6' (2m) cord.
IP65 rated when properly installed.

Engineering data:

conductors: 2 poles plus ground; cable range (connector only):
6 to 8mm (0.24 To 0.31 Inch); contact spacing: 11mm

Most popular.

Replacement Parts

Description	Part number
24VDC solenoid coil kit	P2FCB449
110VAC solenoid coil kit	P2FCB453
Remote pilot kit	P2FP1P
*Includes adaptor, gasket, screws	
Solenoid nut, diffuser	PS1556
Solenoid nut, vented	PS2892P



For inventory, lead times, and kit lookup, visit www.pdnplu.com

P2LAZ 3/2 Single & Double Operators – Solenoid & Remote Air Pilot

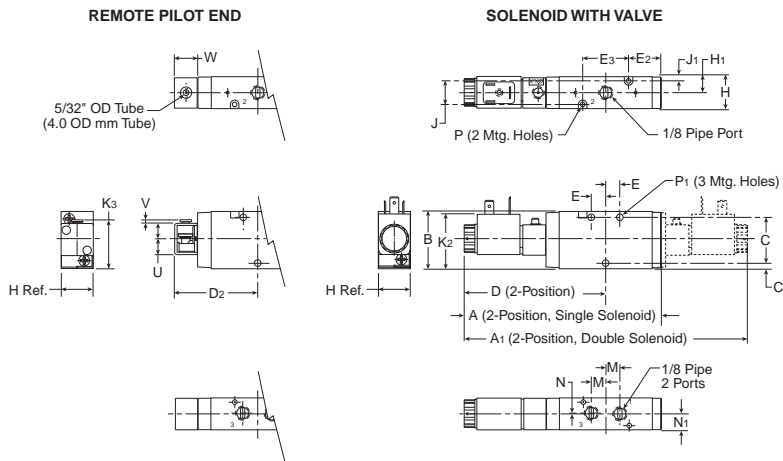

P2LAZ 3/2
Solenoid & remote air pilot

A	A1	B	C	C1	D
5.35 (136)	7.68 (195)	1.57 (40)	1.26 (32)	.16 (4)	3.84 (97.5)
D2	E	E2	E3	H	H1
2.28 (58)	.39 (10)	.91 (23)	1.26 (32)	.87 (22)	.43 (11)
J	J1	K2	K3	M	N
.65 (16.5)	.11 (2.75)	1.50 (38)	1.31 (33.2)	.39 (10)	.02 (.5)
N1	P	P1	U	V	W
.43 (11)	Ø .12 Ø (3.1)	Ø .17 Ø (4.3)	0.43 (11)	0.087 (2.2)	0.59 (15.2)

Inches (mm)

P2LAZ 3/2 Single & Double Operators – IEM Aluminum Bar Manifold

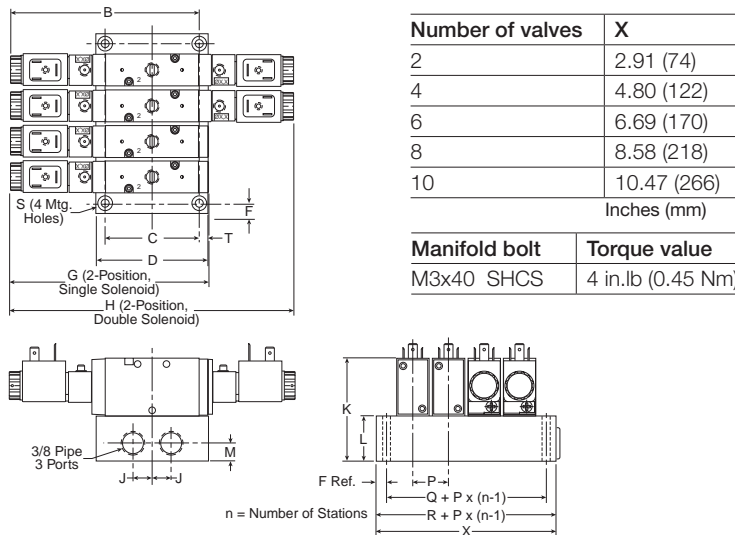

P2LAZ 3/2
IEM Aluminum bar manifold

B	C	D	F	G
5.06 (128.5)	2.44 (62)	2.99 (76)	.28 (7)	5.35 (136)
H	J	K	L	M
7.68 (195)	.51 (13)	2.78 (70.5)	1.20 (30.5)	.47 (12)
P	Q	R	S	T
.94 (24)	1.42 (36)	1.97 (50)	Ø .22 Ø (5.5)	.88 (7)

Inches (mm)

P2LAZ 5/2 & 5/3 Single & Double Operators – Solenoid & Remote Air Pilot

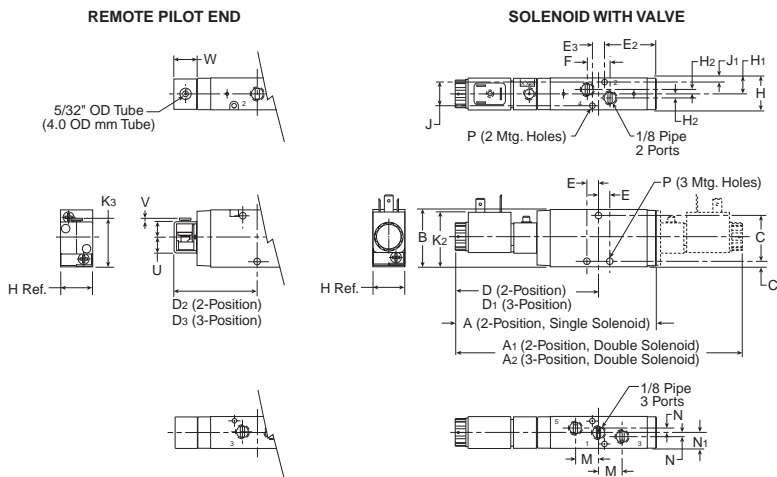

P2LAZ 5/2 & 5/3
Solenoid & remote air pilot

A	A1	A2	B	C	C1
5.47 (139)	7.76 (197)	8.70 (221)	1.57 (40)	1.30 (33)	.14 (3.5)
D	D1	D2	D3	E	E2
3.88 (98.5)	4.35 (110.5)	2.33 (59.3)	2.80 (71)	.31 (8)	1.86 (47.3)
E3	F	H	H1	H2	J
.33 (8.5)	.63 (16)	.87 (22)	.43 (11)	.12 (3)	.63 (16)
J1	K2	K3	M	N	N1
.12 (3)	1.50 (38)	1.31 (33.2)	.63 (16)	.12 (3)	.43 (11)
P	U	V	W		
Ø .16 Ø (4.1)	0.43 (11)	0.087 (2.2)	0.59 (15.2)		

Inches (mm)

C

Inline Valves

Viking Lite

Viking Extreme

"B" Series

Air Saver Unit

ADEX Series

"N" Series



For inventory, lead time, and kit lookup, visit www.pdnplu.com

P2LAZ 5/2 & 5/3 Single & Double Operators – IEM Aluminum Bar Manifold

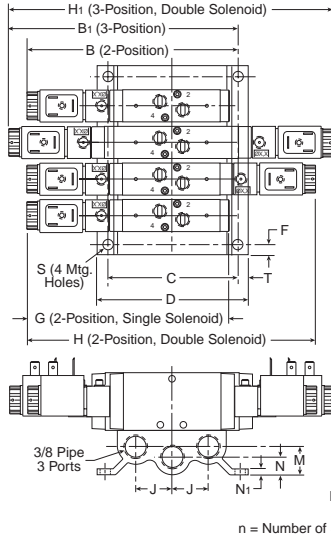

Number of valves	X
2	3.07 (78)
4	4.96 (126)
6	6.85 (174)
8	8.74 (222)
10	10.63 (270)
Inches (mm)	
Manifold bolt	Torque value
M4x45 Screw MRX	9 in.lb (0.75 Nm)

**P2LAZ 5/2 & 5/3
 IEM Aluminum bar manifold**

B	B1	C	D	F
5.10 (149.5)	6.36 (161.5)	3.46 (88)	4.02 (102)	.28 (7)
G	H	H1	J	K
5.47 (139)	7.76 (197)	8.70 (221)	.96 (24.5)	2.76 (70)
L	M	N	N1	P
1.18 (30)	.75 (19)	.47 (12)	.16 (4)	.94 (24)
Q	R	S	T	
1.57 (40)	2.13 (54)	Ø .28 (7)	.28 (7)	
Inches (mm)				

P2LBZ 3/2 Single & Double Operators – Solenoid & Remote Air Pilot

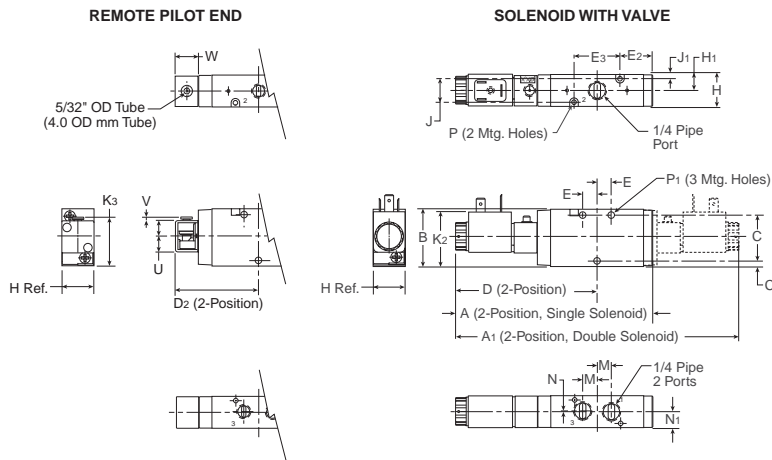

**P2LBZ 3/2
 Solenoid & remote air pilot**

A	A1	B	C	C1	D
5.35 (136)	7.68 (195)	1.57 (40)	1.26 (32)	.16 (4)	3.84 (97.5)
D2	E	E1	E3	H	H1
2.28 (58)	.39 (10)	.91 (23)	1.26 (32)	.87 (22)	.43 (11)
J	J1	K2	K3	M	N
.65 (16.5)	.11 (2.75)	1.50 (38)	1.31 (33.2)	.39 (10)	.02 (.5)
N1	P	P1	U	V	W
.43 (11)	Ø .12 (3.1)	Ø .17 (4.3)	0.43 (11)	0.087 (2.2)	0.59 (15.2)
Inches (mm)					

P2LBZ 3/2 Single & Double Operators – IEM Aluminum Bar Manifold

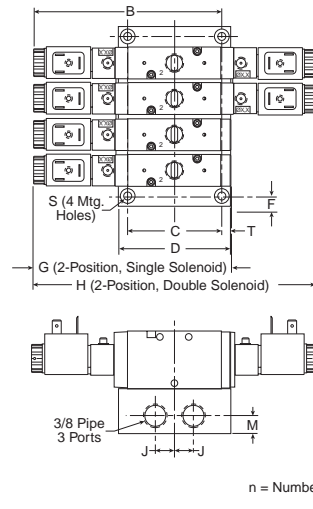

Number of valves	X
2	2.91 (74)
4	4.80 (122)
6	6.69 (170)
8	8.58 (218)
10	10.47 (266)
Inches (mm)	
Manifold bolt	Torque value
M3x40 SCHS	4 in.lb (0.45 Nm)

**P2LBZ 3/2
 IEM Aluminum bar manifold**

B	C	D	F	G
5.06 (128.5)	2.44 (62)	2.99 (76)	.28 (7)	5.35 (136)
H	J	K	L	M
7.68 (195)	.51 (13)	2.78 (70.5)	1.20 (30.5)	.47 (12)
P	Q	R	S	T
.94 (24)	1.42 (36)	1.97 (50)	Ø .22 (5.5)	.88 (7)
Inches (mm)				

P2LBZ 5/2 & 5/3 Single & Double Operators – Solenoid & Remote Air Pilot

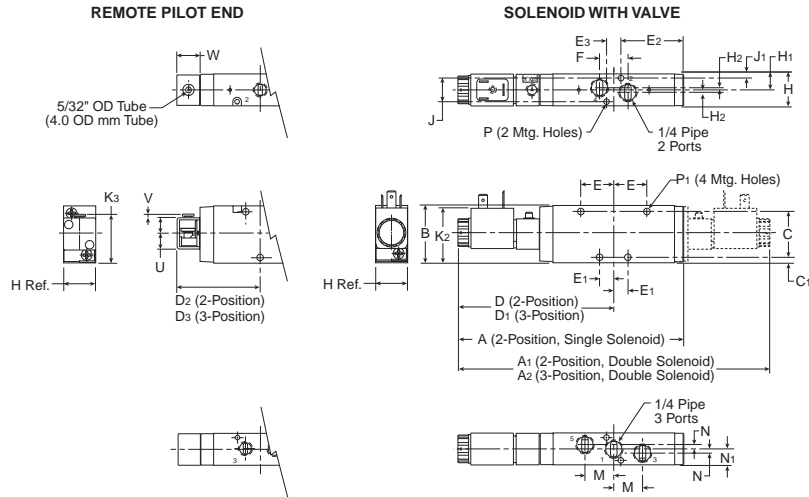

**P2LBZ 5/2 & 5/3
 Solenoid & remote air pilot**

A	A1	A2	B	C	C1
6.14 (156)	8.46 (215)	9.29 (236)	1.57 (40)	1.26 (32)	.16 (4)
D	D1	D2	D3	E	E1
4.23 (107.5)	4.65 (118)	2.68 (68)	3.09 (78.5)	.91 (23)	.39 (10)
E2	E3	F	H	H1	H2
1.14 (29)	.39 (10)	.79 (20)	.87 (22)	.43 (11)	.06 (1.5)
J	J1	K2	K3	M	N
.65 (16.5)	.11 (2.8)	1.50 (38)	1.31 (33.2)	.79 (20)	.08 (2)
N1	P	P1	U	V	W
.43 (11)	Ø .12 Ø (3.1)	Ø .17 Ø (4.3)	0.43 (11)	0.087 (2.2)	0.59 (15.2)

Inches (mm)

P2LBZ 5/2 & 5/3 Single & Double Operators – IEM Aluminum Bar Manifold

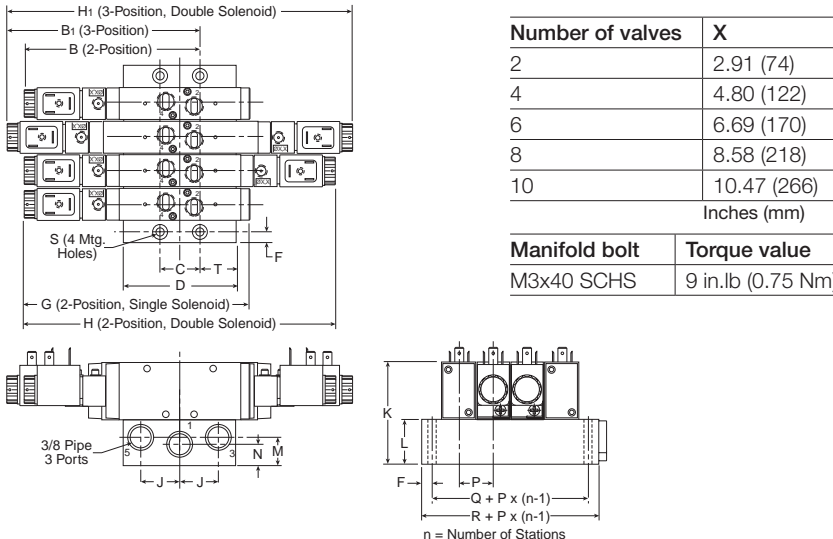

**P2LBZ 5/2 & 5/3
 IEM Aluminum bar manifold**

B	B1	C	D	F
4.43 (112.5)	4.84 (123)	1.04 (26.5)	2.99 (76)	.28 (7)
G	H	H1	J	K
6.14 (156)	8.46 (215)	9.29 (236)	1.02 (26)	2.781 (70.5)
L	M	N	P	Q
1.20 (30.5)	.75 (19)	.57 (14.5)	.94 (24)	1.57 (40)
R	S	T		
1.97 (50)	Ø .22 Ø (5.5)	.97 (25)		

Inches (mm)

P2LCZ 3/2 Single & Double Operators – Solenoid & Remote Pilot

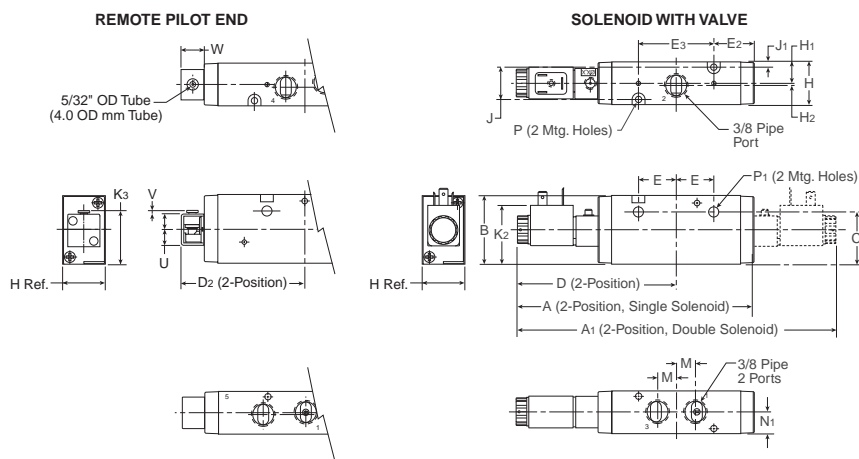

**P2LCZ 3/2
 Solenoid & remote air pilot**

A	A1	B	C	D	D2
6.50 (165)	8.66 (220)	1.89 (48)	1.46 (37)	4.33 (110)	2.78 (70.5)
E	E2	E3	H	H1	H2
1.04 (26.5)	1.10 (28)	2.09 (53)	1.18 (30)	.59 (15)	.06 (1.55)
J	J1	K2	K3	M	N1
.91 (23)	.14 (3.5)	1.50 (38)	1.46 (37.2)	.53 (13.5)	.59 (15)
P	P1	U	V	W	
Ø .17 Ø (4.4)	Ø .27 Ø (6.9)	0.43 (11)	0.087 (2.2)	0.59 (15.2)	

Inches (mm)



For inventory, lead time, and kit lookup, visit www.pdnplu.com

C
 Inline Valves
 Viking Lite
 Viking Extreme
 "B" Series
 Air Saver Unit
 ADEX Series
 "N" Series

P2LCZ 5/2 & 5/3 Single & Double Operators – Solenoid & Remote Air Pilot

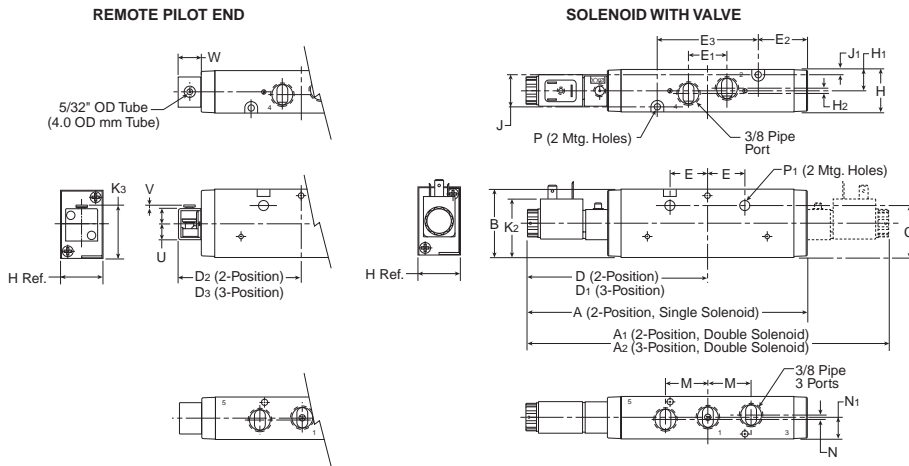

**P2LBZ 5/2 & 5/3
 Solenoid & remote air pilot**

A	A1	A2	B	C
7.68 (195)	9.88 (251)	10.70 (272)	1.89 (48)	1.46 (37)
D	D1	D2	D3	E
4.94 (125.5)	5.35 (136)	3.39 (86)	3.80 (96.5)	1.04 (26.5)
E1	E2	E3	H	H1
1.06 (27)	1.71 (43.5)	2.80 (71)	1.18 (30)	.59 (15)
H2	J	J1	K2	K3
.12 (.3)	.91 (23)	.14 (3.5)	1.50 (38)	1.48 (37.5)
M	N	N1	P	P1
1.18 (30)	.08 (2)	.59 (15)	Ø .17 (Ø 4.4)	Ø .27 (Ø 6.9)
U	V	W		
0.43 (11)	0.087 (2.2)	0.59 (15.2)		

Inches (mm)

P2LCZ 5/2 & 5/3 Single & Double Operators – IEM Aluminum Bar Manifold

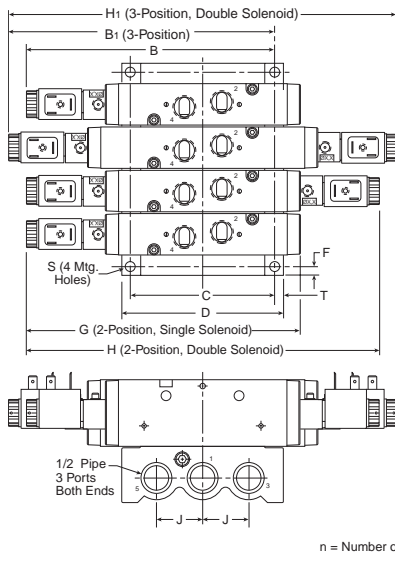

Number of valves	X
2	3.29 (84)
4	5.96 (152)
6	8.44 (215)
8	10.93 (278)
10	13.41 (341)
Inches (mm)	

Manifold bolt	Torque value
M4x50 SCHS	15 in.lb (2.0 Nm)

**P2LCZ 5/2 & 5/3
 IEM Aluminum bar manifold**

C	D	F	G	H
3.97 (101)	4.41 (112)	.24 (6)	7.68 (195)	9.88 (251)
H1	J	K	L	P
10.70 (272)	1.26 (32)	3.43 (87)	1.54 (39)	1.24 (31.5)
Q	R	S	T	
1.77 (45)	2.24 (57)	Ø .26 (Ø 6.5)	.24 (6)	

Inches (mm)

C
 Inline Valves
 Viking Lite
 Viking Extreme
 "B" Series
 Air Saver Unit
 ADEX Series
 "N" Series



For inventory, lead times, and kit lookup, visit www.pdnplu.com

Features

Viking Xtreme Series

The Viking Xtreme valve range is robust, versatile and combines high performance with compact installation dimensions. Large flow capacity, short change-over times and low change-over pressure are important characteristics of this valve range.

Ports

- P2LAX: 1/8 inch NPT & BSPP
- P2LBX: 1/4 inch NPT & BSPP
- P2LCX: 3/8 inch NPT & BSPP
- P2LDX: 1/2 inch NPT & BSPP

Mounting

- Inline
- IEM aluminum bar

Solenoids

- 1.2 watts to 7.3 watts
- 22mm (Type B) & 30mm 3-pin (DIN 43650)
- 15mm 3-pin (EN 17530-803)
- M12, 4-pin, surge suppression
- Grommet, surge suppression
- Conduit
- Deutsche Connectors, surge suppression

12VDC to 240VAC

Certification / approval

- IP65 Rated, RoHS, CE
- CSA Approved to 145 PSIG (10 bar)
- Canada Registration Number available (CRN)
- ATEX option available

Mobile applications

- Viking Xtreme tested to +5g shock and vibration
- Solenoids operate with wide voltage tolerance bands
- Corrosion resistant design
- Passed 500 hour salt spray test

Material specifications

Body	Anodized aluminum
End caps	Anodized aluminum
Coils	Thermoplastic
Fasteners	Stainless steel
Spool	Aluminum and nitrile rubber
Springs	Stainless steel

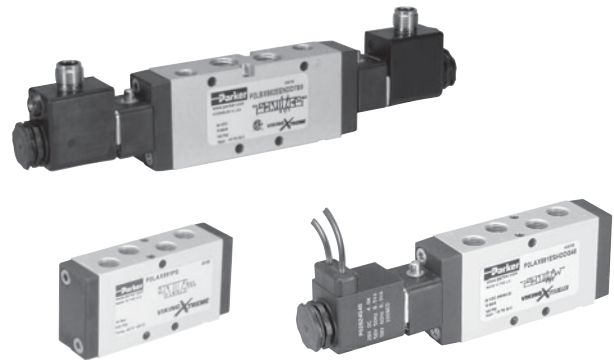

Operating information

Operating pressure:
 Normal: Vacuum to 145 PSIG (Vacuum to 10 bar)
 Xtreme: (P2LAX & P2LBX) Vacuum to 232 PSIG (Vacuum to 16 bar)
 (P2LCX & P2LDX) Vacuum to 174 PSIG (Vacuum to 12 bar)
 Minimum: See chart

Operating temperature:
 Normal: 14°F to 122°F (-10°C to 50°C)
 Xtreme: -40°F to 158°F (-40°C to 70°C)

Minimum operating pressure, PSIG (bar)

Valve type - Internal pilot	P2LAX	P2LBX	P2LCX	P2LDX
Single solenoid - spring return	46 (3.2)	51 (3.5)	51 (3.5)	51 (3.5)
Single remote pilot - spring return	46 (3.2)	51 (3.5)	51 (3.5)	51 (3.5)
Double solenoid - 2-position	22 (1.5)	22 (1.5)	22 (1.5)	22 (1.5)
Double remote pilot - 2-position	22 (1.5)	22 (1.5)	22 (1.5)	22 (1.5)
Double solenoid - 3-position (APB, PC, CE)	51 (3.5)	51 (3.5)	51 (3.5)	51 (3.5)
Double remote pilot - 3-position (APB, PC, CE)	51 (3.5)	51 (3.5)	51 (3.5)	51 (3.5)

Features

Over Molded Spool



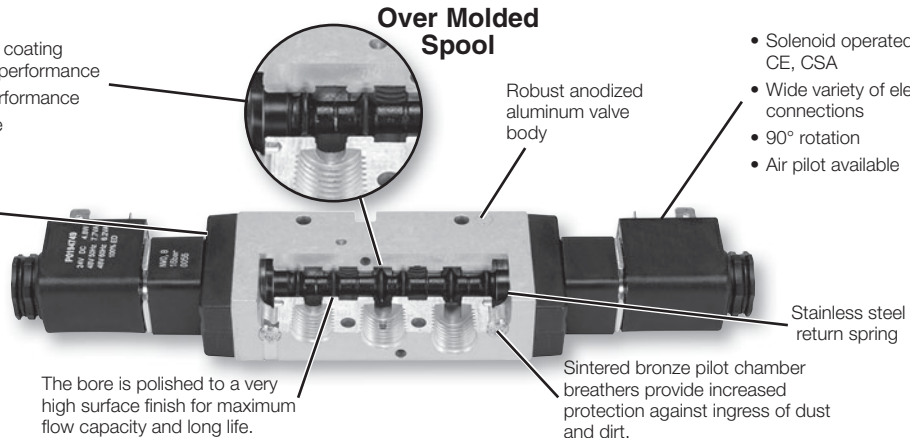

- Aluminum spool with nitrile rubber coating ground to exact size for optimum performance
- Precision ground for maximum performance
- Wide operating temperature range
 - Low temperature to -40°

Diecast end covers with stainless steel screws to resist aggressive environments.



For inventory, lead time, and kit lookup, visit www.pdnplu.com

Single Solenoid, 3-way, 2-position, Normal Operating Pressure / Temperature, Non-locking Manual Override

Solenoid	Port size (NPT)	Cv	Valve type	Response time (msec)	Weight lb (kg)	Voltage	Part number		
 <p>P2LAX 22mm DIN Shown</p>	1/8"	0.7	P2LAX	18 / 40	0.84 (0.38)	24VDC	P2LAX391ESNDDDB49		
						120VAC	P2LAX391ESNDDDB53		
		1/4"	1.3	P2LBX	18 / 45	0.84 (0.38)	24VDC	P2LBX392ESNDDDB49	
							120VAC	P2LBX392ESNDDDB53	
	3/8"	2.5	P2LCX	25 / 75	1.72 (0.78)	24VDC	P2LCX393ESNDDDB49		
						120VAC	P2LCX393ESNDDDB53		
	1/2"	2.7	P2LDX	25 / 75	1.72 (0.78)	24VDC	P2LDX394ESNDDDB49		
	 <p>P2LAX 18" Grommet Shown</p>	1/8"	0.7	P2LAX	18 / 40	0.84 (0.38)	24VDC	P2LAX391ESNDDG49	
							120VAC	P2LAX391ESNDDG53	
			1/4"	1.3	P2LBX	18 / 45	0.84 (0.38)	24VDC	P2LBX392ESNDDG49
								120VAC	P2LBX392ESNDDG53
		3/8"	2.5	P2LCX	25 / 75	1.72 (0.78)	24VDC	P2LCX393ESNDDG49	
120VAC							P2LCX393ESNDDG53		
1/2"		2.7	P2LDX	25 / 75	1.72 (0.78)	24VDC	P2LDX394ESNDDG49		
 <p>P2LAX M12 Coil Shown</p>		1/8"	0.7	P2LAX	18 / 40	0.84 (0.38)	24VDC	P2LAX391ESNDD7B9	
							120VAC	P2LAX391ESNDD7B9	
			1/4"	1.3	P2LBX	18 / 45	0.84 (0.38)	24VDC	P2LBX392ESNDD7B9
								120VAC	P2LBX392ESNDD7B9
		3/8"	2.5	P2LCX	25 / 75	1.72 (0.78)	24VDC	P2LCX393ESNDD7B9	
	120VAC						P2LCX393ESNDD7B9		
	1/2"	2.7	P2LDX	25 / 75	1.72 (0.78)	24VDC	P2LDX394ESNDD7B9		
	 <p>P2LAX 15mm DIN Shown</p>	1/8"	0.7	P2LAX	18 / 40	0.84 (0.38)	24VDC	P2LAX391ESNXB549	
							120VAC	P2LAX391ESNXB553	
			1/4"	1.3	P2LBX	18 / 45	0.84 (0.38)	24VDC	P2LBX392ESNXB549
								120VAC	P2LBX392ESNXB553
		3/8"	2.5	P2LCX	25 / 75	1.72 (0.78)	24VDC	P2LCX393ESNXB549	
120VAC							P2LCX393ESNXB553		
1/2"		2.7	P2LDX	25 / 75	1.72 (0.78)	24VDC	P2LDX394ESNXB549		
120VAC		P2LDX394ESNXB553							

Notes: Above valves are rated for an operating temperature from 14°F to 122°F (-10°C to 50°C). See model code matrix for additional options.
Response time: Actuate to 90% pressure / return to exhaust to 10% of supply pressure. 93 PSIG (6.3 bar) / temperature 68°F (20°C).





 Most popular.

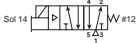

For inventory, lead times, and kit lookup, visit www.pdnplu.com

C
 Inline Valves
 Viking
 Lite
 Viking
 Extreme
 Series
 "B"
 Air Saver
 Unit
 ADEX
 Series
 "N"
 Series

Single Solenoid, 4-way, 2-position, Normal Operating Pressure / Temperature, Non-locking Manual Override

	Solenoid	Port size (NPT)	Cv	Valve type	Response time (msec)	Weight lb (kg)	Voltage	Part number
	22mm DIN	1/8"	0.7	P2LAX	15 / 35	0.49 (0.22)	24VDC	P2LAX591ESNDDDB49
							120VAC	P2LAX591ESNDDDB53
		1/4"	1.3	P2LBX	18 / 45	0.84 (0.38)	24VDC	P2LBX592ESNDDDB49
							120VAC	P2LBX592ESNDDDB53
3/8"	2.5	P2LCX	27 / 75	1.68 (0.76)	24VDC	P2LCX593ESNDDDB49		
					120VAC	P2LCX593ESNDDDB53		
1/2"	2.7	P2LDX	25 / 75	1.68 (0.76)	24VDC	P2LDX594ESNDDDB49		
					120VAC	P2LDX594ESNDDDB53		
 <p>P2LBX 22mm DIN Shown</p>	18" Grommet	1/8"	0.7	P2LAX	15 / 35	0.49 (0.22)	24VDC	P2LAX591ESNDDG49
							120VAC	P2LAX591ESNDDG53
		1/4"	1.3	P2LBX	18 / 45	0.84 (0.38)	24VDC	P2LBX592ESNDDG49
							120VAC	P2LBX592ESNDDG53
3/8"	2.5	P2LCX	27 / 75	1.68 (0.76)	24VDC	P2LCX593ESNDDG49		
					120VAC	P2LCX593ESNDDG53		
1/2"	2.7	P2LDX	25 / 75	1.68 (0.76)	24VDC	P2LDX594ESNDDG49		
					120VAC	P2LDX594ESNDDG53		
 <p>P2LAX 18" Grommet Shown</p>	M12 Coil with LED	1/8"	0.7	P2LAX	15 / 35	0.49 (0.22)	24VDC	P2LAX591ESNDD7B9
							120VAC	P2LAX591ESNDD7B9
		1/4"	1.3	P2LBX	18 / 45	0.84 (0.38)	24VDC	P2LBX592ESNDD7B9
							120VAC	P2LBX592ESNDD7B9
3/8"	2.5	P2LCX	27 / 75	1.68 (0.76)	24VDC	P2LCX593ESNDD7B9		
					120VAC	P2LCX593ESNDD7B9		
1/2"	2.7	P2LDX	25 / 75	1.68 (0.76)	24VDC	P2LDX594ESNDD7B9		
					120VAC	P2LDX594ESNDD7B9		
 <p>P2LAX M12 Coil Shown</p>	15mm DIN	1/8"	0.7	P2LAX	15 / 35	0.49 (0.22)	24VDC	P2LAX591ESNXB549
							120VAC	P2LAX591ESNXB553
		1/4"	1.3	P2LBX	18 / 45	0.84 (0.38)	24VDC	P2LBX592ESNXB549
							120VAC	P2LBX592ESNXB553
3/8"	2.5	P2LCX	27 / 75	1.68 (0.76)	24VDC	P2LCX593ESNXB549		
					120VAC	P2LCX593ESNXB553		
1/2"	2.7	P2LDX	25 / 75	1.68 (0.76)	24VDC	P2LDX594ESNXB549		
					120VAC	P2LDX594ESNXB553		
 <p>P2LAX 15mm DIN Shown</p>								

Notes: Above valves are rated for an operating temperature from 14°F to 122°F (-10°C to 50°C). See model code matrix for additional options.
Response time: Actuate to 90% pressure / return to exhaust to 10% of supply pressure. 93 PSIG (6.3 bar) / temperature 68°F (20°C).





C	Inline Valves
	Viking Lite
	Viking Extreme
	"B" Series
Air Saver Unit	
ADEX Series	
"N" Series	

 Most popular.



For inventory, lead time, and kit lookup, visit www.pdnplu.com

Double Solenoid, 4-way, 2-position, Normal Operating Pressure / Temperature, Non-locking Manual Override

Solenoid	Port size (NPT)	Cv	Valve type	Response time (msec)	Weight lb (kg)	Voltage	Part number	
  22mm DIN P2LBX 22mm DIN Shown	1/8"	0.7	P2LAX	10 / 10	0.60 (0.27)	24VDC 120VAC	P2LAX591EENDDDB49 P2LAX591EENDDDB53	
	1/4"	1.3	P2LBX	12 / 12	0.93 (0.42)	24VDC	P2LBX592EENDDDB49	
						120VAC	P2LBX592EENDDDB53	
	3/8"	2.5	P2LCX	17 / 17	1.78 (0.81)	24VDC	P2LCX593EENDDDB49	
						120VAC	P2LCX593EENDDDB53	
	1/2"	2.7	P2LDX	17 / 17	1.78 (0.81)	24VDC	P2LDX594EENDDDB49	
						120VAC	P2LDX594EENDDDB53	
	 18" Grommet P2LAX 18" Grommet Shown	1/8"	0.7	P2LAX	10 / 10	0.60 (0.27)	24VDC 120VAC	P2LAX591EENDDG49 P2LAX591EENDDG53
		1/4"	1.3	P2LBX	12 / 12	0.93 (0.42)	24VDC	P2LBX592EENDDG49
							120VAC	P2LBX592EENDDG53
		3/8"	2.5	P2LCX	17 / 17	1.78 (0.81)	24VDC	P2LCX593EENDDG49
							120VAC	P2LCX593EENDDG53
1/2"		2.7	P2LDX	17 / 17	1.78 (0.81)	24VDC	P2LDX594EENDDG49	
						120VAC	P2LDX594EENDDG53	
 M12 Coil with LED P2LBX M12 Coil Shown		1/8"	0.7	P2LAX	10 / 10	0.60 (0.27)	24VDC	P2LAX591EENDD7B9
		1/4"	1.3	P2LBX	12 / 12	0.93 (0.42)	24VDC	P2LBX592EENDD7B9
							24VDC	P2LCX593EENDD7B9
		3/8"	2.5	P2LCX	17 / 17	1.78 (0.81)	24VDC	P2LCX593EENDD7B9
								24VDC
1/2"	2.7	P2LDX	17 / 17	1.78 (0.81)	24VDC	P2LDX594EENDD7B9		
 15mm DIN P2LAX 15mm DIN Shown	1/8"	0.7	P2LAX	10 / 10	0.60 (0.27)	24VDC 120VAC	P2LAX591EENXB549 P2LAX591EENXB553	
	1/4"	1.3	P2LBX	12 / 12	0.93 (0.42)	24VDC	P2LBX592EENXB549	
						120VAC	P2LBX592EENXB553	
	3/8"	2.5	P2LCX	17 / 17	1.78 (0.81)	24VDC	P2LCX593EENXB549	
						120VAC	P2LCX593EENXB553	
1/2"	2.7	P2LDX	17 / 17	1.78 (0.81)	24VDC 120VAC	P2LDX594EENXB549 P2LDX594EENXB553		

Notes: Above valves are rated for an operating temperature from 14°F to 122°F (-10°C to 50°C). See model code matrix for additional options.
Response time: Actuate to 90% pressure / return to exhaust to 10% of supply pressure. 93 PSIG (6.3 bar) / temperature 68°F (20°C).





 Most popular.

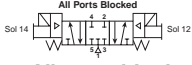
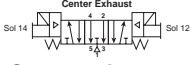

For inventory, lead times, and kit lookup, visit www.pdnplu.com

C
Inline Valves
Viking Lite
Viking Extreme
"B" Series
Air Saver Unit
ADEX Series
"N" Series

**Double Solenoid, 4-way, 3-position All Ports Blocked, 3-position Center Exhaust,
Normal Operating Pressure / Temperature, Non-locking Manual Override**

								Part number		
		Port size (NPT)	Valve Cv	Response time (msec)	Weight lb (kg)	Voltage				
Solenoid							All ports blocked		Center exhaust	
 22mm DIN P2LBX 22mm DIN Shown	1/8"	0.5	P2LAX	18 / 40	0.62 (0.28)	24VDC 120VAC	P2LAX691EENDDDB49 P2LAX691EENDDDB53		P2LAX891EENDDDB49 P2LAX891EENDDDB53	
	1/4"	0.9	P2LBX	22 / 55	0.97 (0.44)	24VDC 120VAC	P2LBX692EENDDDB49 P2LBX692EENDDDB53		P2LBX892EENDDDB49 P2LBX892EENDDDB53	
	3/8"	1.8	P2LCX	30 / 90	2.45 (1.11)	24VDC 120VAC	P2LCX693EENDDDB49 P2LCX693EENDDDB53		P2LCX893EENDDDB49 P2LCX893EENDDDB53	
	1/2"	1.9	P2LDX	30 / 90	2.45 (1.11)	24VDC 120VAC	P2LDX694EENDDDB49 P2LDX694EENDDDB53		P2LDX894EENDDDB49 P2LDX894EENDDDB53	
 18" Grommet P2LBX 18" Grommet Shown	1/8"	0.5	P2LAX	18 / 40	0.62 (0.28)	24VDC 120VAC	P2LAX691EENDDG49 P2LAX691EENDDG53		P2LAX891EENDDG49 P2LAX891EENDDG53	
	1/4"	0.9	P2LBX	22 / 55	0.97 (0.44)	24VDC 120VAC	P2LBX692EENDDG49 P2LBX692EENDDG53		P2LBX892EENDDG49 P2LBX892EENDDG53	
	3/8"	1.8	P2LCX	30 / 90	2.45 (1.11)	24VDC 120VAC	P2LCX693EENDDG49 P2LCX693EENDDG53		P2LCX893EENDDG49 P2LCX893EENDDG53	
	1/2"	1.9	P2LDX	30 / 90	2.45 (1.11)	24VDC 120VAC	P2LDX694EENDDG49 P2LDX694EENDDG53		P2LDX894EENDDG49 P2LDX894EENDDG53	
 M12 Coil with LED P2LBX M12 Coil Shown	1/8"	0.5	P2LAX	18 / 40	0.62 (0.28)	24VDC 120VAC	P2LAX691EENDD7B9		P2LAX891EENDD7B9	
	1/4"	0.9	P2LBX	22 / 55	0.97 (0.44)	24VDC 120VAC	P2LBX692EENDD7B9		P2LBX892EENDD7B9	
	3/8"	1.8	P2LCX	30 / 90	2.45 (1.11)	24VDC 120VAC	P2LCX693EENDD7B9		P2LCX893EENDD7B9	
	1/2"	1.9	P2LDX	30 / 90	2.45 (1.11)	24VDC 120VAC	P2LDX694EENDD7B9		P2LDX894EENDD7B9	
 15mm DIN P2LBX 15mm DIN Shown	1/8"	0.5	P2LAX	18 / 40	0.62 (0.28)	24VDC 120VAC	P2LAX691EENXB549 P2LAX691EENXB553		P2LAX891EENXB549 P2LAX891EENXB553	
	1/4"	0.9	P2LBX	22 / 55	0.97 (0.44)	24VDC 120VAC	P2LBX692EENXB549 P2LBX692EENXB553		P2LBX892EENXB549 P2LBX892EENXB553	
	3/8"	1.8	P2LCX	30 / 90	2.45 (1.11)	24VDC 120VAC	P2LCX693EENXB549 P2LCX693EENXB553		P2LCX893EENXB549 P2LCX893EENXB553	
	1/2"	1.9	P2LDX	30 / 90	2.45 (1.11)	24VDC 120VAC	P2LDX694EENXB549 P2LDX694EENXB553		P2LDX894EENXB549 P2LDX894EENXB553	

Notes: Above valves are rated for an operating temperature from 14°F to 122°F (-10°C to 50°C). See model code matrix for additional options.
 Response time: Actuate to 90% pressure / return to exhaust to 10% of supply pressure. 93 PSIG (6.3 bar) / temperature 68°F (20°C).

 Most popular.



For inventory, lead time, and kit lookup, visit www.pdnplu.com

C

Inline Valves

Viking Lite

Viking Extreme



"B" Series

Air Saver Unit

ADEX Series

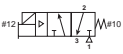

"N" Series

Single Solenoid, 3-way, 2-position, Xtreme Operating Pressure / Temperature, Non-locking Manual Override

Solenoid	Port size (NPT)	Cv	Valve type	Response time (msec)	Weight lb (kg)	Voltage	Part number
  P2LBX 22mm DIN Shown	1/8"	0.7	P2LAX	15 / 45	0.84 (0.38)	12VDC	P2LAX391ESHDDDB47
						24VDC	P2LAX391ESHDDDB48
	1/4"	1.3	P2LBX	25 / 65	0.84 (0.38)	12VDC	P2LBX392ESHDDDB47
						24VDC	P2LBX392ESHDDDB48
	3/8"	2.5	P2LCX	25 / 85	1.01 (0.46)	12VDC	P2LCX393ESHDDDB47
						24VDC	P2LCX393ESHDDDB48
	1/2"	2.7	P2LDX	25 / 85	1.01 (0.46)	12VDC	P2LDX394ESHDDDB47
						24VDC	P2LDX394ESHDDDB48
 P2LBX 18" Grommet Shown	1/8"	0.7	P2LAX	15 / 45	0.84 (0.38)	12VDC	P2LAX391ESHDDG47
						24VDC	P2LAX391ESHDDG48
	1/4"	1.3	P2LBX	25 / 65	0.84 (0.38)	12VDC	P2LBX392ESHDDG47
						24VDC	P2LBX392ESHDDG48
	3/8"	2.5	P2LCX	25 / 85	1.01 (0.46)	12VDC	P2LCX393ESHDDG47
						24VDC	P2LCX393ESHDDG48
	1/2"	2.7	P2LDX	25 / 85	1.01 (0.46)	12VDC	P2LDX394ESHDDG47
						24VDC	P2LDX394ESHDDG48

Notes: Above valves have Mobile Rated Coils and are rated for an operating temperature from -40°F to 158°F (-40°C to 70°C). See model code matrix for additional options.
Response time: Actuate to 90% pressure / return to exhaust to 10% of supply pressure. 93 PSIG (6.3 bar) / temperature 68°F (20°C).

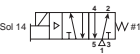
Single Solenoid, 4-way, 2-position, Xtreme Operating Pressure / Temperature Non-locking Manual Override

Solenoid	Port size (NPT)	Cv	Valve type	Response time (msec)	Weight lb (kg)	Voltage	Part number
  P2LBX 22mm DIN Shown	1/8"	0.7	P2LAX	15 / 45	0.84 (0.38)	12VDC	P2LAX591ESHDDDB47
						24VDC	P2LAX591ESHDDDB48
	1/4"	1.3	P2LBX	20 / 55	0.84 (0.38)	12VDC	P2LBX592ESHDDDB47
						24VDC	P2LBX592ESHDDDB48
	3/8"	2.5	P2LCX	25 / 85	1.01 (0.46)	12VDC	P2LCX593ESHDDDB47
						24VDC	P2LCX593ESHDDDB48
	1/2"	2.7	P2LDX	25 / 85	1.01 (0.46)	12VDC	P2LDX594ESHDDDB47
						24VDC	P2LDX594ESHDDDB48
 P2LAX 18" Grommet Shown	1/8"	0.7	P2LAX	15 / 45	0.84 (0.38)	12VDC	P2LAX591ESHDDG47
						24VDC	P2LAX591ESHDDG48
	1/4"	1.3	P2LBX	25 / 65	0.84 (0.38)	12VDC	P2LBX592ESHDDG47
						24VDC	P2LBX592ESHDDG48
	3/8"	2.5	P2LCX	28 / 85	1.01 (0.46)	12VDC	P2LCX593ESHDDG47
						24VDC	P2LCX593ESHDDG48
	1/2"	2.7	P2LDX	25 / 85	1.01 (0.46)	12VDC	P2LDX594ESHDDG47
						24VDC	P2LDX594ESHDDG48

Notes: Above valves have Mobile Rated Coils and are rated for an operating temperature from -40°F to 158°F (-40°C to 70°C). See model code matrix for additional options.
Response time: Actuate to 90% pressure / return to exhaust to 10% of supply pressure. 93 PSIG (6.3 bar) / temperature 68°F (20°C).



 Most popular.



For inventory, lead times, and kit lookup, visit www.pdnplu.com



Common Part Numbers

Double Solenoid, 4-way, 2-position, Xtreme Operating Pressure / Temperature, Non-locking Manual Override

Solenoid	Port size (NPT)	Cv	Valve type	Response time (msec)	Weight lb (kg)	Voltage	Part number	
 <p>22mm DIN</p> <p>P2LBX 22mm DIN Shown</p>	1/8"	0.7	P2LAX	11 / 11	0.60 (0.27)	12VDC	P2LAX591EEHDDDB47	
						24VDC	P2LAX591EEHDDDB48	
	1/4"	1.3	P2LBX	13 / 13	0.93 (0.42)	0.93 (0.42)	12VDC	P2LBX592EEHDDDB47
							24VDC	P2LBX592EEHDDDB48
	3/8"	2.5	P2LCX	18 / 18	1.06 (0.48)	1.06 (0.48)	12VDC	P2LCX593EEHDDDB47
							24VDC	P2LCX593EEHDDDB48
1/2"	2.7	P2LDX	18 / 18	1.06 (0.48)	1.06 (0.48)	12VDC	P2LDX594EEHDDDB47	
						24VDC	P2LDX594EEHDDDB48	
 <p>18" Grommet</p> <p>P2LAX 18" Grommet Shown</p>	1/8"	0.7	P2LAX	11 / 11	0.60 (0.27)	12VDC	P2LAX591EEHDDG47	
						24VDC	P2LAX591EEHDDG48	
	1/4"	1.3	P2LBX	13 / 13	0.93 (0.42)	0.93 (0.42)	12VDC	P2LBX592EEHDDG47
							24VDC	P2LBX592EEHDDG48
	3/8"	2.5	P2LCX	18 / 18	1.06 (0.48)	1.06 (0.48)	12VDC	P2LCX593EEHDDG47
							24VDC	P2LCX593EEHDDG48
1/2"	2.7	P2LDX	18 / 18	1.06 (0.48)	1.06 (0.48)	12VDC	P2LDX594EEHDDG47	
						24VDC	P2LDX594EEHDDG48	

Notes: Above valves have Mobile Rated Coils and are rated for an operating temperature from -40°F to 158°F (-40°C to 70°C). See model code matrix for additional options. Response time: Actuate to 90% pressure / return to exhaust to 10% of supply pressure. 93 PSIG (6.3 bar) / temperature 68°F (20°C).

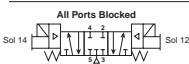
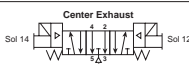
Double Solenoid, 4-way, 3-position All Ports Blocked, 3-position Center Exhaust, Xtreme Operating Pressure / Temperature Non-locking Manual Override

Solenoid	Port size	Cv	Valve type (NPT)	Response time (msec)	Weight lb (kg)	Voltage	Part number		
							All ports blocked	Center exhaust	
 <p>22mm DIN</p> <p>P2LBX 22mm DIN Shown</p>	1/8"	0.5	P2LAX	18 / 40	0.62 (0.28)	12VDC	 Sol 14 P2LAX691EEHDDDB47	 Sol 12 P2LAX891EEHDDDB47	
							24VDC	P2LAX691EEHDDDB48	P2LAX891EEHDDDB48
	1/4"	0.9	P2LBX	22 / 55	0.97 (0.44)	0.97 (0.44)	12VDC	P2LBX692EEHDDDB47	P2LBX892EEHDDDB47
								24VDC	P2LBX692EEHDDDB48
	3/8"	1.8	P2LCX	30 / 90	2.45 (1.11)	2.45 (1.11)	12VDC	P2LCX693EEHDDDB47	P2LCX893EEHDDDB47
								24VDC	P2LCX693EEHDDDB48
1/2"	1.9	P2LDX	30 / 90	2.45 (1.11)	2.45 (1.11)	12VDC	P2LDX694EEHDDDB47	P2LDX894EEHDDDB47	
							24VDC	P2LDX694EEHDDDB48	P2LDX894EEHDDDB48
 <p>18" Grommet</p> <p>P2LBX 18" Grommet Shown</p>	1/8"	0.5	P2LAX	18 / 40	0.62 (0.28)	12VDC	P2LAX691EEHDDG47	P2LAX891EEHDDG47	
							24VDC	P2LAX691EEHDDG48	P2LAX891EEHDDG48
	1/4"	0.9	P2LBX	22 / 55	0.97 (0.44)	0.97 (0.44)	12VDC	P2LBX692EEHDDG47	P2LBX892EEHDDG47
								24VDC	P2LBX692EEHDDG48
	3/8"	1.8	P2LCX	30 / 90	2.45 (1.11)	2.45 (1.11)	12VDC	P2LCX693EEHDDG47	P2LCX893EEHDDG47
								24VDC	P2LCX693EEHDDG48
1/2"	1.9	P2LDX	30 / 90	2.45 (1.11)	2.45 (1.11)	12VDC	P2LDX694EEHDDG47	P2LDX894EEHDDG47	
							24VDC	P2LDX694EEHDDG48	P2LDX894EEHDDG48

Notes: Above valves have Mobile Rated Coils and are rated for an operating temperature from -40°F to 158°F (-40°C to 70°C). See model code matrix for additional options. Response time: Actuate to 90% pressure / return to exhaust to 10% of supply pressure. 93 PSIG (6.3 bar) / temperature 68°F (20°C).

Most popular.



For inventory, lead time, and kit lookup, visit www.pdnplu.com

Ordering Information

Viking Xtreme Single & Double Solenoid Operated Valves

P2L A X 5 91 ES H D D G 49

Valve size	
1/8"	A
1/4"	B
3/8"	C
1/2"	D

Series	
Viking Xtreme	X

Voltage	
B9 ‡	24 VDC w/ surge suppression & LED
42	24VAC
45	12VDC
46 †	12VDC mobile with surge suppression
47 *	12 VDC mobile
48 *	24 VDC mobile
49	24VDC
53	120VAC
57	240VAC
Blank	Valve less coil

* Only available with enclosures "A", "B", "G" & "5".

‡ Enclosure "7" only

† Enclosure "G", "T", "V" only.

C

Inline Valves

Valve type / function	
<i>Internal pilot supply to solenoid*</i>	
3/2 NC - 2-position	3
5/2 2-position	5
5/3 3-position, APB	6
5/3 3-position, PC	7
5/3 3-position, CE	8
<i>External pilot supply to the solenoids through ports #12 & #14</i>	
3/2 NC - 2-position	L
5/2 2-position	N
5/3 3-position, APB	P
5/3 3-position, PC	Q
5/3 3-position, CE	R

* Size A & B solenoid valves can be field converted from internal to external pilot. See page C25 for details.

Main port thread	
G1/8 (P2LA)	11
G1/4 (P2LB)	12
G1/4 (P2LB) NAMUR Mount	1N*
G3/8 (P2LC)	13
G1/2 (P2LD)	14
1/8" NPT (P2LA)	91
1/4" NPT (P2LB)	92
1/4" NPT (P2LB) NAMUR Mount	9N*
3/8" NPT (P2LC)	93
1/2" NPT (P2LD)	94

* NAMUR mount available for 5/2, 2-position only.

Operator return	
Double solenoid	EE
Single solenoid, spring return	ES*

* Not available with 3-position valves.

Enclosures / lead length	
5 †	15mm, 3-pin DIN 43650C, 8mm pin spacing
7 ‡	M12 4-pin coil with surge suppression & LED
A	30mm square 3-pin – ISO 4400 Form A (male only)
B	22mm rectangular 3-pin – type B industrial (male only)
E*	Intrinsically safe, FM / CSA
F †	Hazardous duty 1/2" NPT, FM / CSA
G	Grommet - 18" leads
H	1/2" NPT conduit - 18" leads
N**	Valve less "A - V, 7" enclosure
T #	Grommet, single solenoid, 2-pin deutsche connector, surge suppression
V #	Grommet, double solenoid, 4-pin deutsche connector, surge suppression
X †	Valve less 15mm solenoid

* Only available with voltage code "49" & override option "A", valve type "N" only. Solenoid coil only CSA approved.

** Solenoid pilot type "D" & "N" only.

Voltage code "46" only.

‡ Valve type "N" only. Solenoid coil only CSA approved.

† Solenoid pilot type "X" only.

§ Voltage code "B9" only. Valve type "N" only.

Lite Viking

Extreme Viking

Series "B"

Air Saver Unit

Series ADEX

Series "N"

Valve type / operating pressure and temperature	
Normal, vacuum to 145 PSIG (10 bar), 14°F to 122°F (-10°C to 50°C), CSA Approved	N
Xtreme, vacuum to 145 PSIG (10 bar), -40°F to 140°F (-40°C to 70°C), CSA Approved	K
Xtreme, vacuum to 232 PSIG (16 bar), -40°F to 140°F (-40°C to 70°C)	H*

* P2LC and P2LD solenoid operated valves have a maximum pressure rating of 175 PSIG (12 bar)

Solenoid pilot type	
D**	Vented pilot exhaust
N**	Tapped pilot exhaust
X*	15mm solenoid vented pilot exhaust

* Available enclosure "5", "X" and valve type "N" only.

** Not available on enclosure "5" & "X".

Overrides	
A**	No override
B †	Flush - Non-locking
C *	Flush - locking
D	Extended non-locking
E †	Extended - locking
X †	Valve less 15mm solenoid

* Override for valve type "N" only.

** Not available on enclosure "5", 15mm solenoid. Available solenoid pilot type "D" & "N" only.

† Available solenoid pilot type "X" only.

Most popular.



For inventory, lead times, and kit lookup, visit www.pdnplu.com

Part Numbers / Ordering Information

Remote Pilot Valves

Single Remote Pilot, 3-way, 2-position, Xtreme Operating Pressure / Temperature, Non-locking Manual Override

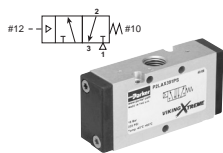

P2LAX Shown

Port size (NPT)	Cv	Response time (msec)	Weight lb (kg)	Valve type	Part number
1/8"	0.7	15 / 45	0.68 (0.31)	P2LAX	P2LAX391PS
1/4"	1.3	25 / 65	0.68 (0.31)	P2LBX	P2LBX392PS
3/8"	2.5	25 / 65	0.88 (0.40)	P2LCX	P2LCX393PS
1/2"	2.7	25 / 65	0.88 (0.40)	P2LDX	P2LDX394PS

Single Remote Pilot, 4-way, 2-position, Xtreme Operating Pressure / Temperature, Non-locking Manual Override

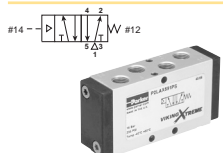

P2LAX Shown

Port size (NPT)	Cv	Response time (msec)	Weight lb (kg)	Valve type	Part number
1/8"	0.7	15 / 45	0.33 (0.15)	P2LAX	P2LAX591PS
1/4"	1.3	20 / 55	0.68 (0.31)	P2LBX	P2LBX592PS
3/8"	2.5	25 / 85	0.90 (0.41)	P2LCX	P2LCX593PS
1/2"	2.7	25 / 85	0.90 (0.41)	P2LDX	P2LDX594PS

Double Remote Pilot, 4-way, 2-position, Xtreme Operating Pressure / Temperature, Non-locking Manual Override

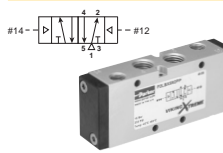

P2LBX Shown

Port size (NPT)	Cv	Response time (msec)	Weight lb (kg)	Valve type	Part number
1/8"	0.7	11 / 11	0.33 (0.15)	P2LAX	P2LAX591PP
1/4"	1.3	13 / 13	0.68 (0.31)	P2LBX	P2LBX592PP
3/8"	2.5	18 / 18	0.90 (0.41)	P2LCX	P2LCX593PP
1/2"	2.7	18 / 18	0.90 (0.41)	P2LDX	P2LDX594PP

Double Remote Pilot, 4-way, 3-position All Ports Blocked, 3-position Center Exhaust, Xtreme Operating Pressure / Temperature, Non-locking Manual Override



P2LBX Shown

Port size (NPT)	Cv	Response time (msec)	Weight lb (kg)	Valve type	Part number	
					All ports blocked	Center exhaust
1/8"	0.5	18 / 50	0.31 (0.14)	P2LAX	P2LAX691PP	P2LAX891PP
1/4"	0.9	25 / 65	0.73 (0.33)	P2LBX	P2LBX692PP	P2LBX892PP
3/8"	1.8	30 / 90	0.93 (0.42)	P2LCX	P2LCX693PP	P2LCX893PP
1/2"	1.9	30 / 90	0.93 (0.42)	P2LDX	P2LDX694PP	P2LDX894PP

Notes: Above valves are rated for an operating temperature from -40°F to 158°F (-40°C to 70°C). See model code matrix for additional options. Response time: Actuate to 90% pressure / return to exhaust to 10% of supply pressure. 93 PSIG (6.3 bar) / temperature 68°F (20°C).

Viking Xtreme Remote Air Pilot Operated Valves

Operating information

Operating pressure:
 (P2LAX & P2LBX)
 Vacuum to 232 PSIG (Vacuum to 16 bar)
 (P2LCX & P2LDX)
 Vacuum to 174 PSIG (Vacuum to 12 bar)

Operating temperature:
 -40°F to 158°F (-40°C to 70°C)

P2 A X 5 91 PS

Valve size	
1/8"	A
1/4"	B
3/8"	C*
1/2"	D*

* P2LCX and P2LDX manual & remote air pilot valves have a maximum pressure rating of 175 PSIG (12 bar).

Valve type / function	
<i>Internal pilot supply to solenoid</i>	
3/2 NC - 2-position	3
5/2 2-position	5
5/3 3-position, APB	6
5/3 3-position, PC	7
5/3 3-position, CE	8

Operators / return	
PP	Double remote pilot
PS*	Single remote pilot, spring return

* Not available with 3-position valves.

Main port thread	
11	G1/8 (P2LA)
12	G1/4 (P2LB)
1N*	G1/4 NPT (P2LB) NAMUR mount
13	G3/8 (P2LC)
14	G1/2 (P2LD)
91	1/8" NPT (P2LA)
92	1/4" NPT (P2LB)
9N*	1/4 NPT (P2LB) NAMUR mount
93	3/8" NPT (P2LC)
94	1/2" NPT (P2LD)

* 5/2, 2-position valve only.

Most popular.



For inventory, lead time, and kit lookup, visit www.pdnplu.com

C

Inline Valves

Viking Lite

Viking Xtreme

"B" Series

Air Saver Unit

ADEX Series

"N" Series

ATEX Certified Single & Double Solenoid Operated Valves

Viking ATEX valves meet ATEX directive 94/9/EC with the following classification : CE Ex II 2GD c 135oc. This directive lays down minimum safety requirements for products intended for use in potentially explosive atmospheres. The Directive is commonly referred to as the 'ATEX' Directive ('ATmospheres EXplosibles'), but may also be called the ATEX Equipment Directive or ATEX 95. Both ATEX certified solenoid, remote pilot and manual operated valves, as well as complete solenoid pilot assemblies are available.



ATEX classification details:

- CE Ex: fulfils the ATEX directive
- II : Group II Equipment Area
- 2GD : Equipment Category 2. Gas Zone 1,2 and Dust Zone 21,22
- c : Safe Design (EN13463-5)
- 135°C : Real temperature of the surface of product for test

Temperature Class of Solenoid : T4 135°C, ATEX 8-22T

Operating information

Operating pressure: Vacuum to 145 PSIG (vacuum to 10 bar)
 Operating temperature: 14°F to 122°F (-10°C to 50°C)

C

Inline Valves

Viking Lite

Viking Extreme

Series "B"

Air Saver Unit

ADEX Series

Series "N"

P2L A X 5 91 ES A D D M 49

Valve size	
1/8"	A
1/4"	B
3/8"	C
1/2"	D

Voltage	
49	24VDC

Enclosures	
M	ATEX 8-22T EExm T4 135°C

Valve type / function		
Internal Pilot Supply to Solenoid		
2-position valve		5
3-position valve APB		6
3-position valve PC		7
3-position valve CE		8
External Pilot Supply to Solenoids through Ports #12 & #14		
2-position valve		N
3-position valve APB		P
3-position valve PC		Q
3-position valve CE		R

Overrides	
D	Extended non-locking

Solenoid pilot type	
D	Vented pilot exhaust
N	Tapped pilot exhaust (M5)

Operator return	
EE	Double solenoid
ES*	Single solenoid, spring return

* Not available with 3-position valves.

Main port thread	
G1/8 (P2LA)	11
G1/4 (P2LB)	12
G3/8 (P2LC)	13
G1/2 (P2LD)	14
1/8" NPT (P2LA)	91
1/4" NPT (P2LB)	92
3/8" NPT (P2LC)	93
1/2" NPT (P2LD)	94

NOTE:

- ATEX Valve includes a coil with sealed 3 meter cable.
- Replacement solenoid kit P2FS13A3DM49 includes coil with sealed 3 meter cable, valve armature, solenoid, solenoid nut, screws and o-rings.

These products are designed for utilization in applications falling under the scope of ATEX Directive 94/9/EC. This coverage could only be referred to as long as operations required for the installation and the maintenance of these products are complying with related standards.



For inventory, lead times, and kit lookup, visit www.pdnplu.com

Accessories

IEM Bar Manifolds

IEM Bar Manifold, Viking Xtreme Solenoid / Remote Pilot Valves †



Valve series	Valve function	## - Stations	Manifold only (NPT)	Manifold only (BSPP)
P2LAX*	3-way	02 - 12	P2LAXGAXN##NP	P2LAXGAXG##NP
P2LAX*	4-way	02 - 12	P2LAXMAXN##NP	P2LAXMAXG##NP
P2LBX*	3-way	02 - 12	P2LBXGAXN##NP	P2LBXGAXG##NP
P2LBX*	4-way	02 - 12	P2LBXMAXN##NP	P2LBXMAXG##NP
P2LCX*	3-way / 4-way	02 - 12	P2LCXMAXN##NP	P2LCXMAXG##NP

Kits include: (1) manifold, valve hold down bolts and o-rings. Replace ## with number of valve stations. Valve size A, B, C only.

* Enclosure option A,E & F can not be mounted on size A & B manifolds and enclosure F can not be mounted on size C manifolds due to width of solenoid,

Enclosure option A & E can be mounted on size A & B manifolds if valve is a single solenoid valve and if every other valve is mounted in reverse (staggered).

† Consider Viking Lite manifolds for alternative solutions.

IEM Bar Manifold Add-A-Fold Assembly (Viking Xtreme Solenoid / Remote Air Pilot Valves Only)



Valve series	Valve function	## - Stations	Manifold only (NPT)	Manifold only (BSPP)
P2LAX*	3-way	02 - 12	AAP2LAXGAXN##NP	AAP2LAXGAXG##NP
P2LAX*	4-way	02 - 12	AAP2LAXMAXN##NP	AAP2LAXMAXG##NP
P2LBX*	3-way	02 - 12	AAP2LBXGAXN##NP	AAP2LBXGAXG##NP
P2LBX*	4-way	02 - 12	AAP2LBXMAXN##NP	AAP2LBXMAXG##NP
P2LCX*	3-way / 4-way	02 - 12	AAP2LCXMAXN##NP	AAP2LCXMAXG##NP

Kits include: (1) manifold, valve hold down bolts, o-rings and assembly. Replace ## with number of valve stations. Valve size A, B, C only.

* Enclosure option A,E & F can not be mounted on size A & B manifolds and enclosure F can not be mounted on size C manifolds due to width of solenoid,

How to Order: 1. List Add-A-Fold assembly part number as line item 1

2. List the desired valves series part number in subsequent line items after the Add-A-Fold Assembly part number to complete the ordering code. Include all valves and blanking kits required. The left most station is station # 1 looking at the #12 end of the manifold.

Example: Viking Size B, 2 Station manifold, with 2, 4-way single solenoid valves

Line	Qty	Part number	Comment
1	1	AAP2LBXMAXN02NP	Add-A-Fold Assembly, 2-station IEM bar manifold
2	2	P2LBX592ESHDDB49	4-way, Station 1, 2

Blanking Plate

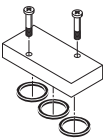

Type	Kit number
P2LAX 4-way	9121658063
P2LBX 4-way	9121594809X
P2LCX 3 & 4 way	P2LCXK20P
P2LAX 3-way	912132BPSXZ
P2LBX 3-way	912132BPSXZ

Kit includes: plate, screws, o-rings

Manifold Bolts

Type	Qty.	Kit number
P2LAX	12	P2LAXK87P
P2LBX	12	P2LBXK87P
P2LCX	12	P2LCXK87P

Manifold O-rings

Type	Qty.	Kit number
P2LAX	30	P2LAXK84P
P2LBX	18	P2LBXK84P
P2LCX	12	P2LCXK84P

Most popular.



For inventory, lead time, and kit lookup, visit www.pdnplu.com

Solenoids with Deutsche Connections : Environmentally-Sealed Transportation Connectors

Viking valves with solenoid options “T” & “V” include a grommet lead wire solenoid with internal surge suppression connected to Deutsche DTP Series male connectors. Heat shrunk cover holds the grommet lead wires together between the solenoid and deutsche connector. An environmentally-sealed connector designed specifically for cable to cable applications in harsh environments such as on the engine or transmission, under the hood, on the chassis or in the cab applications. On signal

level circuits where even a small degradation in connection may be critical, these connectors will provide the reliability and performance when properly connected to DTP female connector assemblies. Thermoplastic housings with silicone seals are used to allow the connector to withstand conditions of extreme temperature and moisture. Properly wired and mated connection will withstand immersion under three feet of water without loss of electronic qualities or leakage.

Deutsche Connector & Solenoid Information

		“T” Single Solenoid Option	“V” Double Solenoid Option
Solenoid Kit		P2FCT446	P2FCV446
Connector Information	Housing material	Thermoplastic	Thermoplastic
	Grommet seal material	Silicone	Silicone
	Connector housing / seal number	DT04-2P*	DT04-4P*
	Contact material	Copper alloy	Copper alloy
	Contact number	0460-202-16141*	0460-202-16141*
	Sealing plug (Wedge) material	Thermoplastic	Thermoplastic
	Wedge number	W2P*	W4P*
	Temperature rating of connector	-67°F (-55°C) to +257°F (+125°C)	-67°F (-55°C) to +257°F (+125°C)
	Solenoid	Voltage	12VDC +10%, -30% mobile with bi-directional surge suppression
Number of solenoids		1	2
Connector pin out		pin 1 & 2	12 solenoid : pin 1 & 2 14 solenoid : pin 3 & 4
Wire length (Connector to solenoid)		19" (483mm)	12 Solenoid : 19" (482mm) 14 Solenoid : 7.75" (196.5mm)
Exposed insulated wire (a)		0.25" (6.4mm) - 0.5" (12.7mm)	0.25" (6.4mm) - 0.5" (12.7mm)
Exposed insulated wire (b)		0.75" (19.1mm) - 1.5" (38.1mm)	0.75" (19.1mm) - 1.5" (38.1mm)
Wire cover material		Heat shrunk PVC	Heat shrunk PVC

* Deutsche Industrial reference numbers. Male connections provided, mating female components and assemblies can be sourced from qualified Deutsche connector distributors.

Enclosure / Lead Length - Option “T”



Solenoid Kit P2FCT446 shown

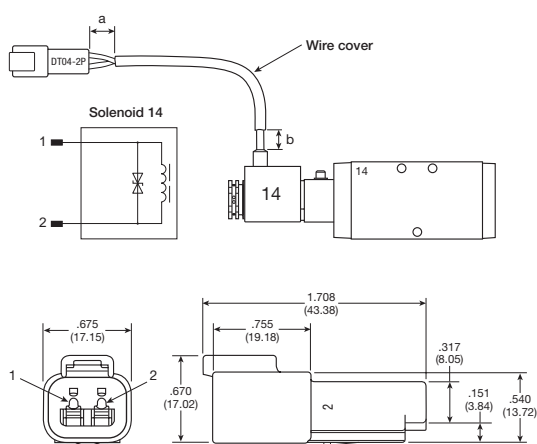

Enclosure / Lead Length - Option “V”



Solenoid Kit P2FCV446 shown

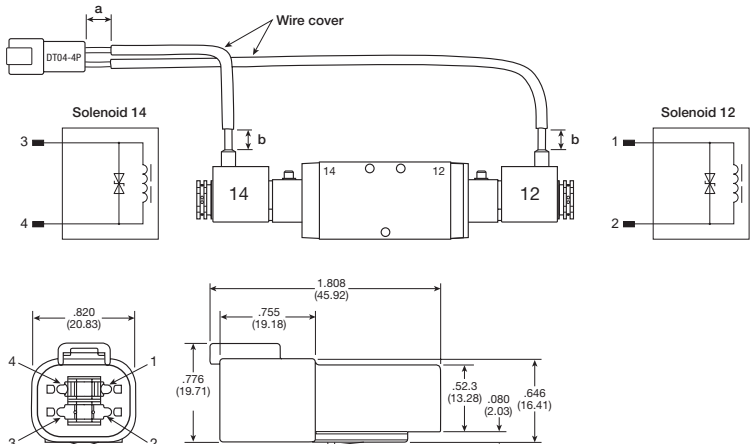

Pilot Operator Kits

P2FP13 N 4 C

Type	Overrides
Pilot operator kit P2FP13	A No override
	C* Locking (bistable) flush - plastic
	D Non-locking (monostable) extended - brass

* Only available with "N" Pressure / Temperature option.

Pressure / temperature	
145 PSIG (10 bar) 14°F to 122°F (-10°C to 50°C)	N
232 PSIG (16 bar) -40°F to 158°F (-40°C to 70°C)	H

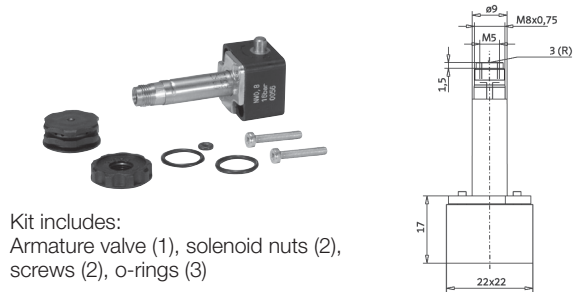

Operator mounting pattern (mm)

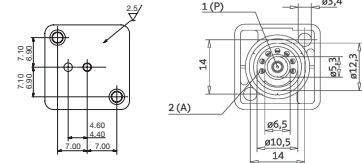

Solenoid Pilot Operators & Coils

Solenoid pilot options

The P2FP13*4* (NC) 3/2 solenoid pilot operators are designed for piloting pneumatic control valves with compressed air or other inert gases.

The P2FP operator is available for Normal operating pressures up to 10 bar or the Xtreme maximum operating pressure of 16 bar and wide band voltage tolerances required for mobile applications.

Corrosion resistant design

The pilot valve body is manufactured in thermoplastic PA6 material and the core tube brass / stainless steel. The plunger / core is made from stainless steel and the valve seats from FKM.

Solenoid pilot exhaust

These operators all exhaust out of the top of the core tube which is tapped M5. The standard solenoid nut (Solenoid pilot type "D") fitted to the core tube is a diffuser nut which allows the exhaust to escape to atmosphere. This nut also minimizes ingress of dirt into the valve through this port. The alternative plastic knurled nut (Solenoid pilot type "N") can be specified (refer to part number system) if the exhaust air needs captured and piped away using the M5 tapped port.

Mobile applications

Viking Xtreme valves are tested to +5g shock and vibration. Solenoid operated valves are designed to operate with wide voltage tolerance bands within the ambient temperature ranges stated in the technical section.

Coils

Coils are wound with enameled copper wire, having a temperature index of 180°C with class F insulation (155°C) and are encapsulated in Thermoplastic resin. When fitted with suitable connector and correct gasket, they give protection to IP65.

 Most popular.

Manual override options

The pilot operators can be supplied with locking or non-locking manual override. The standard manual override is the monostable (spring return) extended brass override. Alternatively the bistable (locking) override can be specified as an alternative for the Normal duty 10 bar option.

Spares

Solenoid operators are available as spares complete with mounting screws and seals. Coils and connectors should be ordered separately unless ATEX certified and intrinsically safe is needed. ATEX certified operators and coils must be ordered together.

Transients

Interrupting the current through the solenoid coil produces momentary voltage peaks which, under unfavorable conditions, can amount to several hundred times the rated operating voltage. Normally, these transients do not cause problems, but to achieve the maximum life of relays in the circuit (and particularly of transistors, thyristors and integrated circuits) it is desirable to provide protection by means of voltage-dependent resistors (varistors). All connectors / cable plugs with LEDs include this type of circuit protection.

Materials

Pilot Valve	
Body	Polyamide
Armature tube:	
Normal pilot operator	Brass
Xtreme pilot operator.....	Stainless steel
Plunger & core.....	Corrosion resistant CR-NI steel
Seals	FKM
Screws	Stainless steel
Coil	
Encapsulation material.....	Thermoplastic

C
Inline Valves
Viking Lite
Viking Extreme
"B" Series
Air Saver Unit
ADEX Series
"N" Series



For inventory, lead time, and kit lookup, visit www.pdnplu.com

Solenoid Kits

Solenoid Enclosures

P2FC B 4 49

Type	C
Solenoid Kit	C

Voltage	
B9 ‡	24 VDC w/ surge suppression & LED
42	24VAC
45	12VDC
46 †	12 VDC mobile w/ surge suppression
47*	12 VDC mobile
48*	24 VDC mobile
49	24VDC
53	120VAC
57	240VAC

Enclosures / lead length	
M12 4-pin coil with surge suppression & LED	7 §
30mm square 3-pin – ISO 4400 Form A (male only)	A
22mm rectangular 3-pin – Type B Industrial (male only)	B
Hazardous duty, FM / CSA	F*
Grommet - 18" leads	G
1/2" NPT conduit - 18" leads	H
Grommet, single solenoid, 2-pin deutsche connector, surge suppression	T #
Grommet, double solenoid, 4-pin deutsche connector, surge suppression	V #
Grommet 72" leads	Q
1/2" conduit 72" leads	R

* Only available with voltage codes "45", "49", "53" & "57". Not for use with the Xtreme version (-40°C to 70°C).

Voltage code 46 only.

§ Voltage code B9 only.

* Only available with enclosures "A", "B" & "G". Additional voltages are available upon request. Contact customer support for more information.

‡ Enclosure 7 only

† Enclosure G, T, V only.

Solenoid Kits – 3-Pin, EN175301-803 (Former DIN 43650C), 15mm, 8mm



Standard

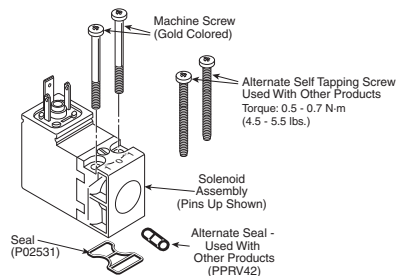

PS2982*##P – Enclosure '5'

* Override	## Voltage						
	42	45	47 †	48 †	49	53	57
B	O	O	S	S	S	S	O
C	O	O	S	S	S	S	O
D	O	O	O	O	O	O	O
E	O	O	O	O	O	O	O

S - Standard; O - Option

† Mobile voltage

Kit includes: Solenoid, (2) machine screws, (2) self threading screws, (1) gasket, (1) 3-cell gasket.



Option 7
M12, 4-Pin Coil with Surge Suppression



Option A
30mm Square, 3-Pin ISO 4400, DIN 43650A



Option B
22mm Rectangular, 3-Pin DIN, Type B Industrial



Option G & Q
Grommet, 18" or 72" Leads



Option H & R
1/2" Conduit, 18" or 72" Leads

Solenoid Information (Solenoids are rated for continuous duty.)

Voltage Code	Enclosure "5"			Enclosure "A"			Enclosure "7", "B" to "R"		
	AC 60Hz	50Hz	DC	Power consumption	Holding (Amps)	Power consumption	Holding (amps)	Power consumption	Holding (amps)
B9†	—	—	24	—	—	—	—	4.8W	.20
42	24	22	—	1.6VA	.065	3.9VA	.14	7.3VA	.31
45	—	—	12	1.2W	.098	2.6W	.21	4.6W	.37
46†	—	—	12	—	—	—	—	5.5W	.46
47*	—	—	12	0.91W	.074	6.2W	.52	5.5W	.46
48*	—	—	24	0.91W	.033	6.8W	.29	6.0W	.25
49	—	—	24	1.2W	.049	2.7W	.11	4.8W	.20
53	120	110	—	1.6W	.013	4.1VA	.04	6.3VA	.05
57	240	230	—	1.6W	.007	3.7VA	.02	6.4VA	.03

* Mobile voltages. † Surge suppression.

■ Most popular.



For inventory, lead times, and kit lookup, visit www.pdnplu.com

Intrinsically safe solenoid valves (“E” option)

Hazardous location class:

Class I; Groups A, B, C & D

Class II; Groups E, F, & G

Class III; Div. I

For use in low voltage (24VDC) Intrinsically Safe applications.
 NO OTHER VOLTAGE IS APPROVED.

Comes standard with non-lighted solenoid connector.

36mm Coil width.

Must be connected to an FM approved Barrier.

For dimensions, reference standard solenoid models.

Maximum internally piloted valve pressure is 115 PSIG.

Pressures to 145 PSIG can be used when external pilot is utilized and pilot pressure is limited to 115 PSIG.

The intrinsically safe coil width (30mm) is wider than the body width of valve type A & B valves. If mounted on a manifold, the valves need to be staggered to fit and must be single solenoid valves only.

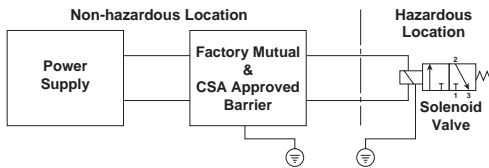

Intrinsically safe solenoid pilot assembly kits

Description	Part number
24VDC	P2FS13N1AE49

Kit includes: coil, armature, connector, o-ring & screws

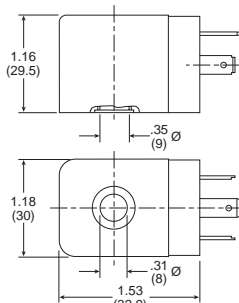
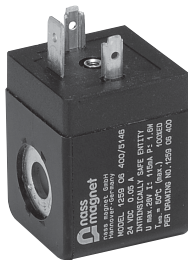

Hazardous duty solenoid valves (“F” option)

Hazardous location class:

Class I; Zone I EX, M, II & T4

Class I; Div. I, Groups A, B, C, & D

Class II & III; Div. I, Groups E, F, & G

Comes standard with 1/2" conduit connection.

Voltage range = ±10%

Ambient temperature range = -20°C (-4°F) to 60°C (140°F)

Duty factor = 100%

IP65 Rated (with connected conduit connector)

Notes:

1. Maximum non-hazardous location voltage not to exceed 250V RMS.
2. Factory Mutual requires connections per ISA RP 12.6 instructions.
3. CSA requires “Installation to be in accordance with the Canadian Electrical Code. Part I.”
4. The hazardous duty coil width (36mm) is wider than the body width of valve type A, B, C & D valves. Valves can not be mounted to IEM manifolds without installing a blanking plate between valves.

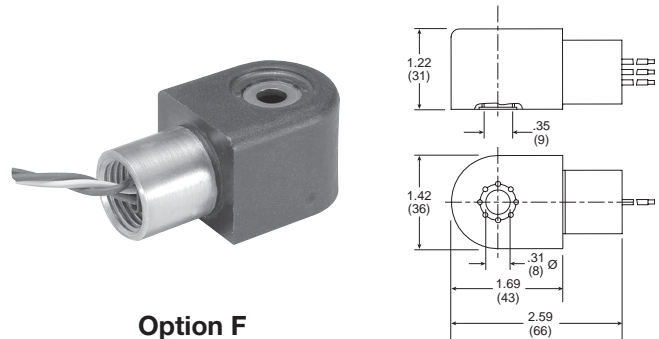

**Option F
 Hazardous Duty FM / CSA**

M12, 24VDC solenoid coil (“7” option)

Connection type: M12, metal thread, M12 x 1

DIN EN 60947-5-2 appendix D

LED color: yellow

Bi-directional surge suppression

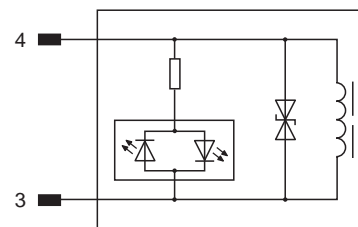
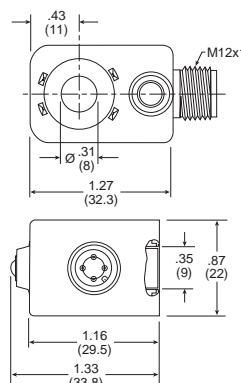

1. Not Used
2. Not Used
3. +/- (blue)
4. +/- (black)

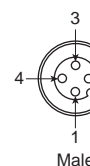

**4-Pin Female Wiring Diagram
 (only Pins 4 & 3 are used)
 Per ISO 20401**



For inventory, lead time, and kit lookup, visit www.pdnplu.com

C	Inline Valves
	Viking Lite
	Viking Xtreme
	“B” Series
	Air Saver Unit
	ADEX Series
	“N” Series

Internal to external pilot conversion (size A & B only)

To convert from Internal to External Pilot Valve, simply remove the (2) fasteners that attach the end cap to the valve body. Rotate the end cap 180° and attach back to the valve body. For single solenoid valves, only the 14-End needs to be rotated. For double solenoid valves, both ends must be converted for proper function.

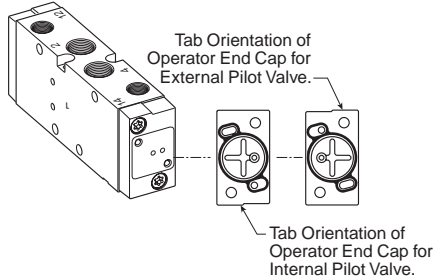

The 12 & 14-Ports are always tapped no matter what Valve Type / Function is selected. For Internal Pilot Function, ports do NOT need to be plugged.

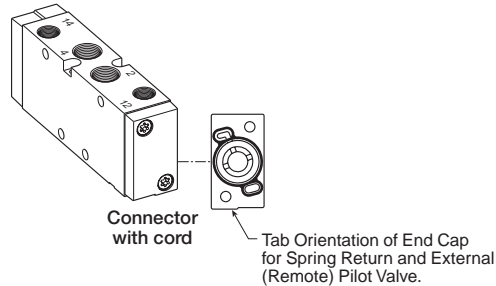

22mm Rectangular 3-Pin – Type B Industrial
 (Use with Enclosure “B”)

Description	Connector with 6' (2m) cord	Connector
Unlighted	PS2429JBP	PS2429BP
Light – 24V/60Hz, 24VDC	PS2430J79BP*	PS243079BP
Light – 120V/60Hz	PS2430J83BP*	PS243083BP
Light – 240V/60Hz	N/A	PS243087BP

* LED with surge suppression.
Note: Max ø6.5mm cable size required for connector w/o 6' (2m) cord. IP65 rated when properly installed.

Engineering Data:
 Conductors: 2 Poles Plus Ground; Cable Range (Connector Only): 6 to 8mm (0.24 to 0.31 Inch); Contact Spacing: 11mm

M12 A-code Cables

Description	Part number
4-Pin female to flying lead cable, PVC, 2m	RKC 4.4T-2

RKC Female Sockets

* Only pins 3 and 4 are used with solenoids Option “7”.

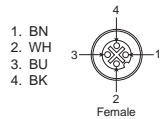
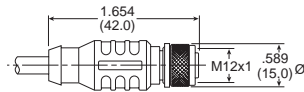

4-Pin Female Wiring Diagram

15mm Solenoid Mount

Description	Part number
15mm solenoid mount	P2FA22-15



Kit includes: adapter (1), O-rings (2), gasket (1), screws (4)

 Most popular.

15mm 3-Pin DIN 43650C
 (Use with Enclosure “5”)

	Cord length	Connector	Connector only	Connector with cord
Unlighted	18 Inches	PS2932BP	PS2932HBP	
Unlighted	6 Feet	PS2932BP	PS2932JBP	
Light – 12VAC or DC	6 Feet	PS294675BP	PS2946J75BP*	
Light – 24VAC or DC	6 Feet	PS294679BP	PS2946J79BP*	
Light – 110/120VAC	6 Feet	PS294683BP	PS2946J83BP*	
Light – 240/230VAC		PS294687BP	N/A	

* LED with surge suppression.
Note: Max ø6.5mm cable size required for connector w/o 6' (2m) cord. IP65 rated when properly installed.

Engineering data:
 Conductors: 2 poles plus ground Cable range (connector only): 4 to 6mm (0.16 to 0.24 Inch) Contact spacing: 8mm

30mm Square 3-Pin – ISO 4400, DIN 43650A
 (Use with Enclosure “A”)

Description	Connector with 6' (2m) cord	Connector
Unlighted	PS2028JCP	PS2028BP
Light – 6-48V, 50/60Hz, 6-48VDC	PS2032J79CP*	PS203279BP
Light – 120V/60Hz	PS2032J83CP*	PS203283BP
Light – 240V/60Hz	N/A	PS203283BP

* LED with surge suppression.
Note: Max ø6.5mm cable size required for connector w/o 6' (2m) cord. IP65 rated when properly installed.

Engineering data:
 Conductors: 2 poles plus ground; cable range (connector only): 8 to 10mm (0.31 To 0.39 Inch); contact spacing: 18mm

Replacement Solenoid Nut

Description	Part number	Description	Part number
Solenoid diffuser nut	PS1556	Solenoid vented nut	PS2892P



For inventory, lead times, and kit lookup, visit www.pdnplu.com

It is the users responsibility to verify product performance when applied at maximum tolerance ranges of multiple technical specifications simultaneously.

Operating temperature

- **Normal**.....14°F to 122°F (-10°C to 50°C)
- **Xtreme**..... -40°F to 158°F (-40°C to 70°C)

Flow Rating

Valve size	Port size	2-position	3-position
P2LAX	1/8"	0.7	0.5
P2LBX	1/4"	1.3	0.9
P2LCX	3/8"	2.5	1.8
P2LDX	1/2"	2.7	1.9

Operating pressure*

Maximum: Normal.....145 PSIG (10 bar)
Xtreme.....232 PSIG (16 bar)

Minimum:

Valve type - internal pilot	Minimum PSIG (bar)			
	P2LAX	P2LBX	P2LCX	P2LDX
Single solenoid - spring return	46 (3.2)	51 (3.5)	51 (3.5)	51 (3.5)
Single remote pilot - spring return	46 (3.2)	51 (3.5)	51 (3.5)	51 (3.5)
Double solenoid - 2-position	22 (1.5)	22 (1.5)	22 (1.5)	22 (1.5)
Double remote pilot - 2-position	22 (1.5)	22 (1.5)	22 (1.5)	22 (1.5)
Double solenoid - 3-position (APB, PC, CE)	51 (3.5)	51 (3.5)	51 (3.5)	51 (3.5)
Double remote pilot - 3-position (APB, PC, CE)	51 (3.5)	51 (3.5)	51 (3.5)	51 (3.5)

Valve type - External pilot	P2LAX	P2LBX	P2LCX	P2LDX
All Viking series	Vacuum			

* P2LC and P2LD solenoid operated valves have a maximum pressure rating of 175 PSIG (12 bar).

Size A and B solenoid valves can be field converted from internal pilot to external pilot and visa versa. See previous page for information.

Solenoid voltage characteristics

Non-Mobile Coil -

Voltage Code 42, 45, 49, 53, 57
 15mm, DIN 43650C (Enclosure: 5)
 +10%, -15%

Mobile Coil -

Voltage Code 47, 48
 15mm, Din 43650C (Enclosure: 5)
 +25%, -30%

Voltage Code 46
 (Enclosure G,T,V)
 +10%, -30%

Solenoid voltage characteristics

Non-mobile coils -

Voltage code B9, 42, 45, 49, 53, 57
 Enclosure (7, A, B, E, F, G, H)
 +10%, -10%

Mobile coils - (valve type N)

22mm 12 & 24VDC - Mobile (47 & 48 voltage code)

Operating temperature			
Minimum inlet pressure (bar)	-10°C	+10°C	+50°C
	3	+30 / -25% VDC	+30 / -20% VDC
6	+30 / -30% VDC	+30 / -25% VDC	+25 / -20% VDC
8	+30 / -30% VDC	+30 / -30% VDC	+25 / -25% VDC
10	+30 / -30% VDC	+30 / -30% VDC	+25 / -30% VDC

30mm 12 & 24VDC - Mobile (47 & 48 voltage code)

Operating temperature			
Minimum inlet pressure (bar)	-10°C	+10°C	+50°C
	3	+30 / -30% VDC	+30 / -30% VDC
6	+30 / -30% VDC	+30 / -30% VDC	+25 / -30% VDC
8	+30 / -30% VDC	+30 / -30% VDC	+25 / -30% VDC
10	+30 / -30% VDC	+30 / -30% VDC	+25 / -30% VDC

Mobile coils - (valve type K & H)

22mm 12 & 24VDC - Mobile (47 & 48 voltage code)

Operating temperature				
Minimum inlet pressure (bar)	-40°C	+10°C	+50°C	+70°C
	4	+30 / -25% VDC	+30 / -25% VDC	+30 / -10% VDC
8	+30 / -30% VDC	+30 / -25% VDC	+30 / -15% VDC	+20 / -15% VDC
12	+30 / -30% VDC	+30 / -30% VDC	+30 / -15% VDC	+20 / -15% VDC
16	+30 / -30% VDC	+30 / -30% VDC	+30 / -20% VDC	+20 / -20% VDC

30mm 12 & 24VDC - Mobile (47 & 48 voltage code)

Operating temperature				
Minimum inlet pressure (bar)	-40°C	+10°C	+50°C	+70°C
	4	+30 / -30% VDC	+30 / -30% VDC	+25 / -30% VDC
8	+30 / -30% VDC	+30 / -30% VDC	+25 / -30% VDC	+15 / -30% VDC
12	+30 / -30% VDC	+30 / -30% VDC	+25 / -30% VDC	+15 / -30% VDC
16	+30 / -30% VDC	+30 / -30% VDC	+25 / -30% VDC	+15 / -30% VDC

Note: All table ratings are based on 100% continuous duty and 5G shock vibration. At 50% continuous duty all ratings are +30% / -30% for all Temperatures and Pressures.

C
 Inline Valves
 Viking Lite
 Viking Xtreme
 "B" Series
 Air Saver Unit
 ADEX Series
 "N" Series



For inventory, lead time, and kit lookup, visit www.pdnplu.com

Exhaust Protector

Features

- 1/8 and 1/4 NPT male sizes
- Fitted with a brass pipe adapter and a fluorocarbon membrane
- Resistant to rust, clog, wash down and contamination

Applications

These protectors are intended for mobile applications, quick venting applications and alternative exhaust port breathers that require protection against clogging.

Ideal for valves exposed to harsh environmental conditions (which can cause a "caking up" in the exhaust pipe ports where the bronze mufflers or breather vents are installed).

Particularly suitable for time-sensitive applications such as axle-lift suspensions or pushers or tag axles.

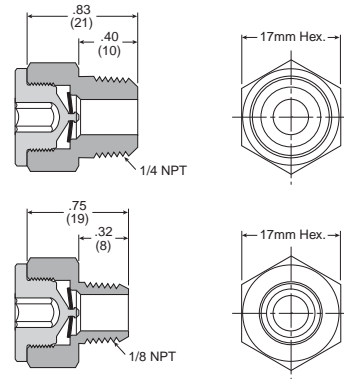

Operating information

Operating pressure:	0 to 150 PSIG (0 to 10 bar)
Operating temperature:	-40°F to 140°F (-40°C to 60°C)

Flow data (SCFM)

Size	60 PSIG Inlet	90 PSIG Inlet	125 PSIG Inlet	Part number
1/8"	40.1	56.5	75.5	E90016
1/4"	44.6	62.7	83.5	E90017

Material specifications

Body & pipe adapter	Brass
Membrane	Fluorocarbon

Exhaust Mufflers

Pipe thread	Part number
M5	P6M-PAC5
1/8" NPT	EM12
1/4" NPT	EM25
3/8" NPT	EM37
1/2" NPT	EM50

P6M - Plastic; EM - Sintered bronze



Plastic Silencers

Thread size	A (mm)	B (mm)	Part number		
			NPT	BSPT	Metric
M5	.43 (11)	.32 (8)	-	-	AS-5
1/8"	1.57 (40)	.63 (16)	ASN-6	AS-6	-
1/4"	2.56 (65)	.83 (21)	ASN-8	AS-8	-
3/8"	3.35 (85)	.98 (25)	ASN-10	AS-10	-
1/2"	3.74 (95)	1.18 (30)	ASN-15	AS-15	-

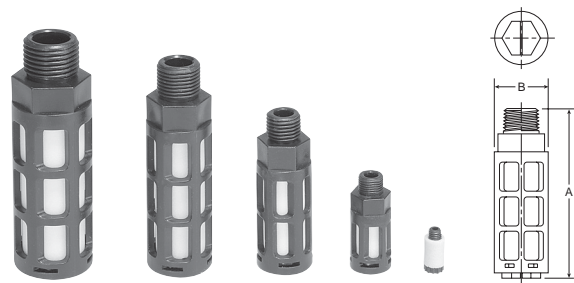

C

Inline Valves

Viking Lite

Viking Extreme

"B" Series

Air Saver Unit

ADEX Series

"N" Series

68PM Male Connector

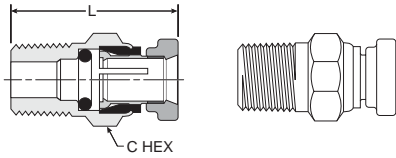

Part number	Tube size	Pipe thread (NPTF)	C hex	L
68PM-2-1	1/8	1/16	3/82	0.93
68PM-2-2	1/8	1/8	7/16	0.88
68PM-5/32-1	5/32	1/16	3/8	0.95
68PM-5/32-2	5/32	1/8	7/16	0.74
68PM-5/32-4	5/32	1/4	9/16	0.99
68PM-3-1	3/16	1/16	7/16	0.95
68PM-3-2	3/16	1/8	7/16	0.92
68PM-3-4	3/16	1/4	9/16	1.10

68PMT Male Connector

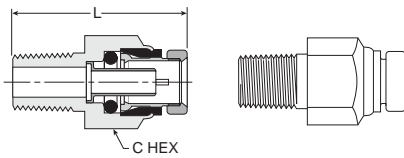

Part number	Tube size	Pipe thread (NPTF)	C hex	L
68PMT-4-2	1/4	1/8	1/2	1.06
68PMT-4-4	1/4	1/4	9/16	1.19
68PMT-4-6	1/4	3/8	3/4	1.27
68PMT-6-2	3/8	1/8	3/4	1.37
68PMT-6-4	3/8	1/4	3/4	1.43
68PMT-6-6	3/8	3/8	3/4	1.33
68PMT-6-8	3/8	1/2	7/8	1.38
68PMT-8-4	1/2	1/4	7/8	1.72
68PMT-8-6	1/2	3/8	7/8	1.52
68PMT-8-8	1/2	1/2	7/8	1.44
68PMT-10-6	5/8	3/8	1	1.88
68PMT-10-8	5/8	1/2	1	1.88
68PMT-12-8	3/4	1/2	1-3/16	2.03

169PMNS Male Elbow Non-Swivel 90°

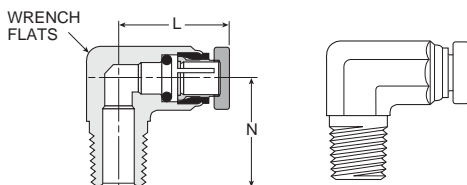

Part number	Tube size	Pipe thread (NPTF)	Wrench flats	L	N
169PMNS-2-2	1/8	1/8	3/8	0.86	0.68
169PMNS-5/32-2	5/32	1/8	3/8	0.88	0.68
169PMNS-3-2	3/16	1/8	3/8	0.75	0.67
169PMNS-3-4	3/16	1/4	1/2	0.74	0.93

169PMT Male Elbow Swivel 90°

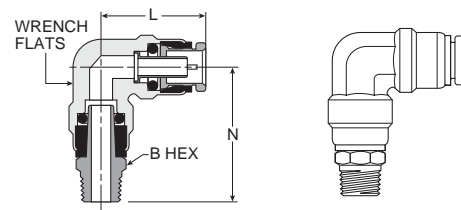

Part number	Tube size	Pipe Thread (NPTF)	Wrench flats	B hex	L	N
169PMT-4-2	1/4	1/8	13/32	7/16	0.84	1.21
169PMT-4-4	1/4	1/4	13/32	9/16	0.84	1.43
169PMT-4-6	1/4	3/8	13/32	11/16	0.84	1.43
169PMT-6-2	3/8	1/8	9/16	9/16	1.11	1.41
169PMT-6-4	3/8	1/4	9/16	9/16	1.11	1.58
169PMT-6-6	3/8	3/8	9/16	11/16	1.11	1.58
169PMT-6-8	3/8	1/2	9/16	7/8	1.11	1.79
169PMT-8-4	1/2	1/4	11/16	5/8	1.27	1.73
169PMT-8-6	1/2	3/8	11/16	3/4	1.27	1.81
169PMT-8-8	1/2	1/2	11/16	7/8	1.27	1.96
169PMT-10-6	5/8	3/8	7/8	3/4	1.53	2.03
169PMT-10-8	5/8	1/2	7/8	7/8	1.53	2.18

169PMTL Male Elbow Long Non-Swivel 90°

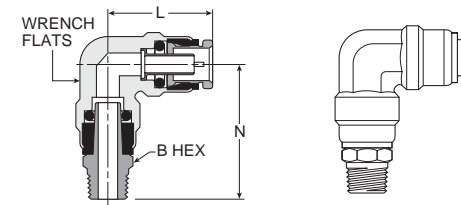

Part number	Tube size	Pipe Thread (NPTF)	Wrench flats	B hex	L	N
169PMTL-6-4	3/8	1/4	9/16	9/16	1.06	1.63
169PMTL-6-6	3/8	3/8	9/16	7/8	1.19	2.50
169PMTL-6-8	3/8	1/2	9/16	7/8	1.19	2.50
169PMTL-8-8	1/2	1/2	11/16	7/8	1.22	2.50
169PMTL-10-8	5/8	1/2	7/8	7/8	1.46	2.50

C

Inline Valves

Viking Lite

Viking Extreme

"B" Series

Air Saver Unit

ADEX Series

"N" Series



For inventory, lead time, and kit lookup, visit www.pdnplu.com

Accessories

Inline Valve Products, Viking Xtreme Connectors

169PMTNS Male Elbow Non-Swivel 90°

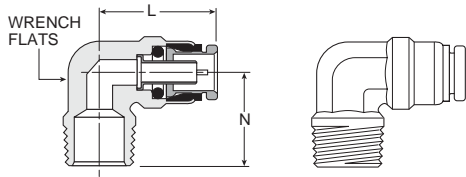

Part number	Tube size	Pipe thread (NPTF)	Wrench flats	L	N
169PMTNS-4-2	1/4	1/8	1/2	0.84	0.72
169PMTNS-4-4	1/4	1/4	1/2	0.84	0.90
169PMTNS-4-6	1/4	3/8	1/2	0.84	1.06
169PMTNS-6-2	3/8	1/8	9/16	1.05	0.75
169PMTNS-6-4	3/8	1/4	9/16	1.05	0.94
169PMTNS-6-6	3/8	3/8	3/4	1.05	0.94
169PMTNS-6-8	3/8	1/2	11/16	1.12	1.26
169PMTNS-8-4	1/2	1/4	11/16	1.17	1.06
169PMTNS-8-6	1/2	3/8	11/16	1.22	1.06
169PMTNS-8-8	1/2	1/2	11/16	1.22	1.26
169PMTNS-10-6	5/8	3/8	7/8	1.46	1.11
169PMTNS-10-8	5/8	1/2	7/8	1.46	1.32
169PMTNS-12-8	3/4	1/2	1	1.81	1.44

171PMTNS Male Run Tee Non-Swivel

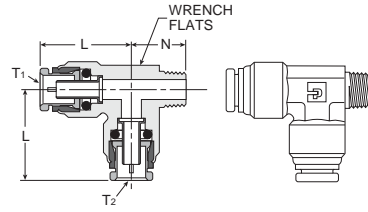

Part number	Tube 1 size	Tube 2 size	Pipe thread (NPTF)	Wrench flats	L1	L2	N
171PMTNS-4-4	1/4	1/4	1/4	15-32	0.91	0.91	0.94
171PMTNS-4-6-4	1/4	3/8	1/4	5/8	0.93	1.21	0.97
171PMTNS-6-4	3/8	3/8	1/4	5/8	1.21	1.21	0.97
171PMTNS-6-4-4	3/8	1/4	1/4	5/8	1.21	0.93	0.97
171PMTNS-6-4-6	3/8	1/4	3/8	5/8	1.22	0.97	0.93
171PMTNS-6-6	1/2	3/8	3/8	5/8	1.21	1.27	0.97
171PMTNS-6-8	1/2	3/8	1/2	5/8	1.17	1.27	1.26
171PMTNS-8-4	1/2	1/2	1/4	7/8	1.28	1.27	1.06

172PMT Male Branch Tee Swivel

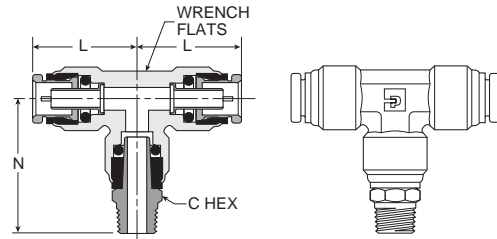

Part number	Tube size	Pipe thread (NPTF)	Wrench flats	C hex	L	N
172PMT-4-2	1/4	1/8	1/2	7/16	0.85	1.25
172PMT-4-4	1/4	1/4	1/2	9/16	0.85	1.43
172PMT-6-2	3/8	1/8	5/8	9/16	1.22	1.66
172PMT-6-4	3/8	1/4	5/8	5/8	1.22	1.83
172PMT-6-6	3/8	3/8	5/8	3/4	1.22	1.83
172PMT-8-4	1/2	1/4	7/8	5/8	1.27	1.73
172PMT-8-6	1/2	3/8	7/8	3/4	1.27	1.79
172PMT-8-8	1/2	1/2	7/8	7/8	1.27	1.97

171PMT Male Run Tee Swivel

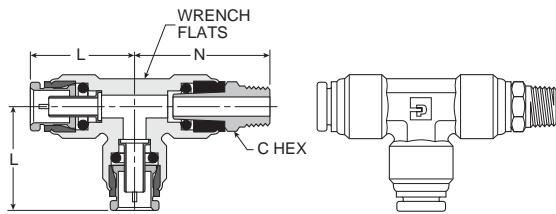

Part number	Tube size	Pipe thread (NPTF)	Wrench flats	L	N	N
171PMT-4-2	1/4	1/8	1/2	7/16	.85	1.25
171PMT-4-4	1/4	1/4	1/2	9/16	.85	1.48
171PMT-4-6	1/4	3/8	1/2	11/16	.85	1.43
171PMT-6-4	3/8	1/4	5/8	9/16	1.21	1.83
171PMT-6-6	3/8	3/8	5/8	11/16	1.21	1.83
171PMT-8-4	1/2	1/4	7/8	5/8	1.27	1.74
171PMT-8-6	1/2	3/8	7/8	3/4	1.27	1.83
171PMT-8-8	1/2	1/2	7/8	7/8	1.27	1.99

172PMTNS Male Branch Tee Non-Swivel

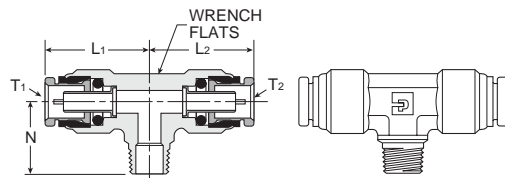

Part number	Tube 1 size	Tube 2 size	Pipe thread (NPTF)	Wrench flats	L1	L2	N
172PMTNS-4-2	1/4	1/4	1/8	1/2	0.91	0.91	0.78
172PMTNS-6-4	3/8	3/8	1/4	5/8	1.21	1.21	0.97
172PMTNS-6-4-4	3/8	1/4	1/4	5/8	1.21	.93	0.97
172PMTNS-6-6	3/8	3/8	3/8	5/8	1.21	1.21	0.97
172PMTNS-6-8	3/8	3/8	1/2	7/8	1.17	1.17	1.26
172PMTNS-8-6	1/2	1/2	3/8	7/8	1.28	1.28	1.06
172PMTNS-8-6-8	1/2	3/8	1/2	7/8	1.25	1.25	1.25
172PMTNS-8-8	1/2	1/2	1/2	7/8	1.34	1.25	1.25

C
Inline Valves
Viking Lite
Viking Xtreme
"B" Series
Air Saver Unit
ADEX Series
"N" Series



For inventory, lead times, and kit lookup, visit www.pdnplu.com

Spool Service Kits

Description	Includes items (qty.)	Part number
Size A, 4-way, 2-position, solenoid & air pilot valves	1 (1), 3 (2), 4 (2)	P2LAXSK1
Size A, 4-way, 3-position, solenoid & air pilot valves	1 (1), 2 (2), 3 (2), 4 (2)	P2LAXSK2
Size A & Size B, 3-way, 2-position, solenoid & air pilot valves	1 (1), 3 (2), 4 (2)	P2LAXBXSK1
Size B, 4-way, 2 & 3-position valves	1 (1), 3 (2), 4 (2)	P2LBXSK1
Size C & Size D, 3-way, 2-position valves	1 (1), 3 (2), 4 (2)	P2LCXDYSK1
Size C & Size D, 4-way, 2 & 3-position valves	1 (1), 3 (2), 4 (2)	P2LCXDYSK1

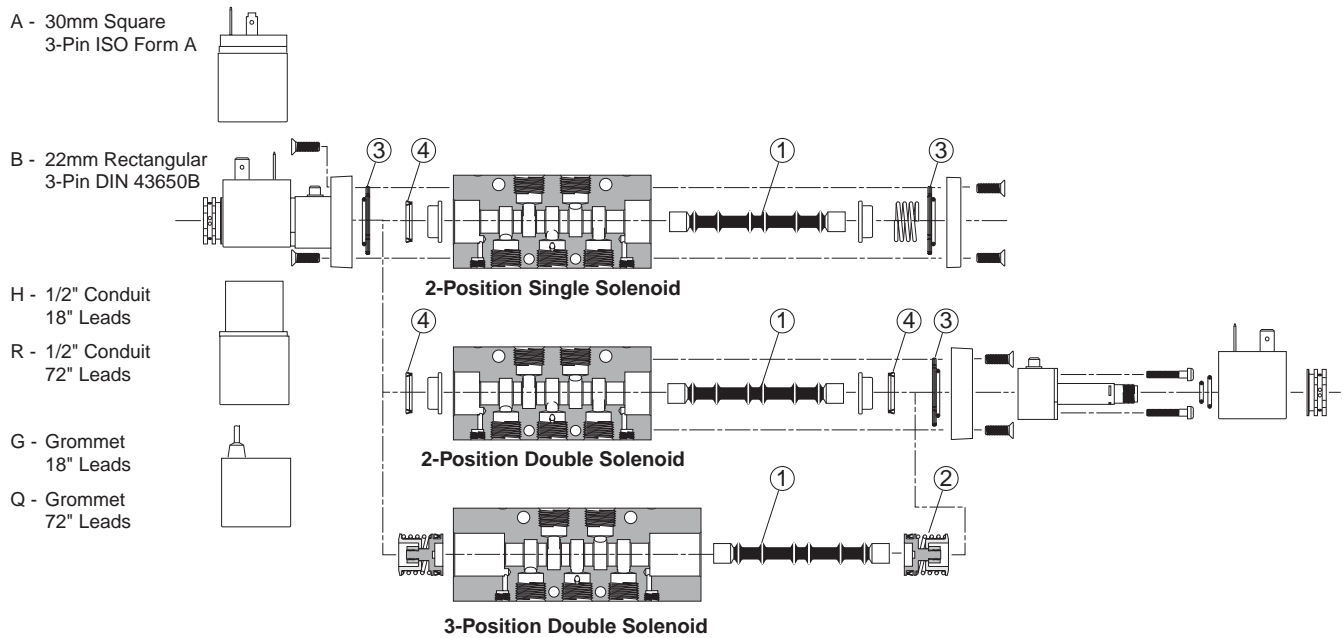

C
Inline Valves
Viking Lite
Viking Xtreme
"B" Series
Air Saver Unit
ADEX Series
"N" Series



For inventory, lead time, and kit lookup, visit www.pdnplu.com

P2LAX 3/2 Single & Double Operators – Solenoid

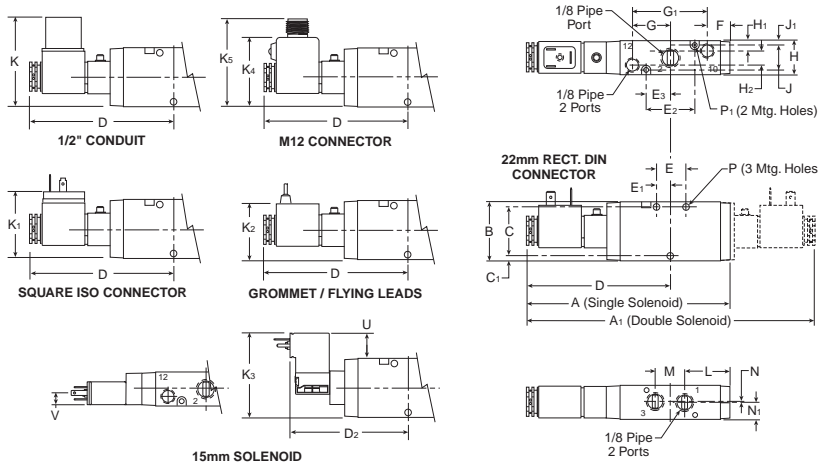

P2LAX 3/2 (solenoid)

A	A1	B	C	C1	D
5.35 (136)	7.60 (193)	1.57 (40)	1.26 (32)	.16 (4)	3.80 (97)
D2	E	E1	E2	E3	F
3.00 (76.8)	.79 (20)	.39 (10)	1.26 (32)	.63 (16)	.55 (14)
G	G1	H	H1	H2	J
.98 (25)	1.97 (50)	.87 (22)	.26 (6.6)	.35 (9)	.65 (16.5)
J1	K	K1	K2	K3	K4
.11 (2.9)	2.36 (60)	1.61 (41)	1.50 (38)	2.24 (57)	1.70 (43.3)
K5	L	M	N	N1	P
2.10 (53.3)	1.14 (29)	.79 (20)	.02 (0.5)	.42 (11)	Ø .17 (4.3)
P1	U	V			
Ø .12 (3.1)	0.81 (20.5)	0.29 (7.5)			

Inches (mm)

P2LAX 3/2 Single & Double Operators – Remote Air Pilot

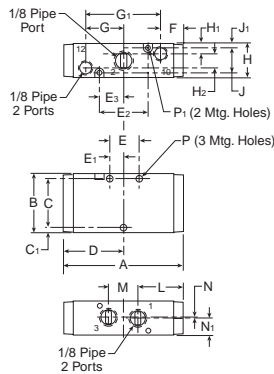

P2LAX 3/2 (remote air pilot)

A	B	C	C1	D	E
3.07 (78)	1.57 (40)	1.26 (32)	.16 (4)	1.54 (39)	.79 (20)
E1	E2	E3	F	G	G1
.39 (10)	1.26 (32)	.63 (16)	.55 (14)	.98 (25)	1.97 (50)
H	H1	H2	J	J1	L
.87 (22)	.26 (6.6)	.35 (9)	.65 (16.5)	.11 (2.9)	1.14 (29)
M	N	N1	P	P1	
.79 (20)	.02 (0.5)	.42 (11)	Ø .17 (4.3)	Ø .12 (3.1)	

Inches (mm)

P2LAX 5/2 & 5/3 Single & Double Operators, 4-way

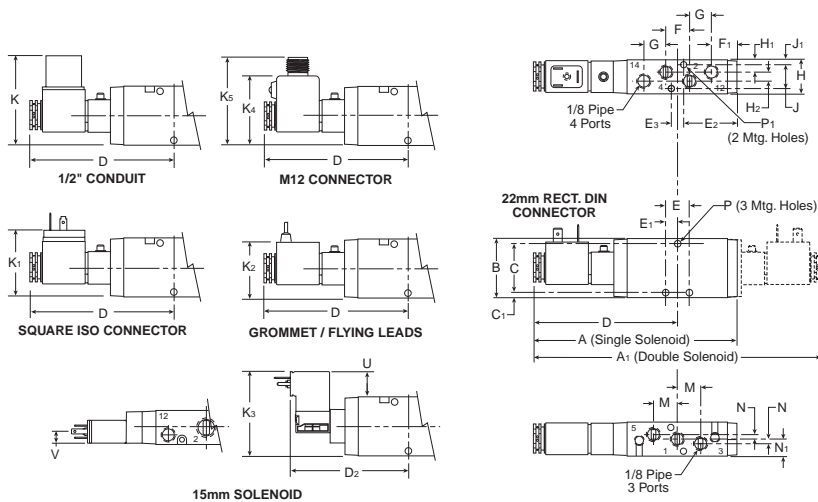

P2LAX 5/2 & 5/3 (solenoid)

A	A1	B	C	C1	D
5.47 (139)	7.72 (196)	1.57 (40)	1.30 (33)	.14 (3.5)	3.86 (98)
D2	E	E1	E2	E3	F
3.48 (88.3)	.63 (16)	.31 (8)	1.42 (36)	.33 (8.5)	.63 (16)
F1	G	H	H1	H2	J
.67 (17)	.59 (15)	.87 (22)	.31 (8)	.24 (6)	.63 (16)
J1	K	K1	K2	K3	K4
.12 (3.9)	2.36 (60)	1.61 (41)	1.50 (38)	2.24 (57)	1.63 (41.3)
K5	M	N	N1	P	P1
2.10 (53.3)	.63 (16)	.12 (3)	.43 (11)	Ø .17 (4.3)	Ø .12 (3.1)
U	V				
0.81 (20.5)	0.29 (7.5)				

Inches (mm)

C
 Inline Valves
 Viking Lite
 Viking Xtreme
 "B" Series
 Air Saver Unit
 ADEX Series
 "N" Series

P2LAX 5/2 & 5/3 Single & Double Operators – Remote Pilot

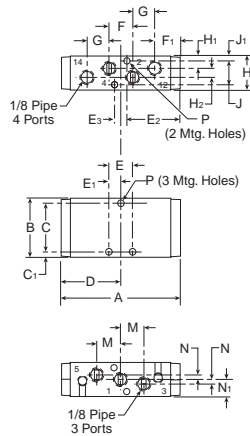

P2LAX 5/2 & 5/3 (remote)

A	B	C	C ₁	D
3.19 (81)	1.57 (40)	1.30 (33)	.14 (3.5)	1.59 (40.5)
E	E ₁	E ₂	E ₃	F
1.47 (16)	.31 (8)	1.42 (36)	.33 (8.5)	.63 (16)
F ₁	G	H	H ₁	H ₂
.67 (17)	.59 (15)	.87 (22)	.31 (8)	.24 (6)
J	J ₁	M	N	N ₁
.63 (16)	.12 (3)	.63 (16)	.12 (3)	.43 (11)
P	P ₁			
Ø .17 Ø (4.3)	Ø .12 Ø (3.1)			

Inches (mm)

P2LAX 3/2 Single & Double Operators – IEM Aluminum Bar Manifold

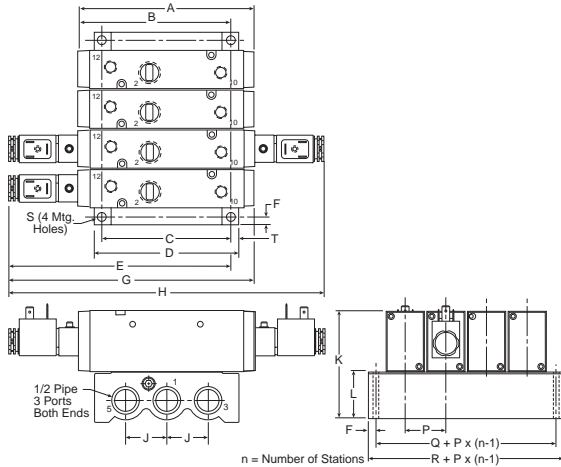

**P2LAX 3/2
 IEM Aluminum bar manifold**

A	B	C	D	E
3.07 (78)	2.83 (72)	2.76 (70)	3.12 (79)	5.18 (132)
F	G	H	J	K
41 (10.5)	5.35 (136)	7.72 (193)	.87 (22)	3.11 (79)
L	M	N	P	Q
1.54 (39)	.87 (22)	.52 (13.2)	.93 (23.5)	1.56 (39.5)
R	S	T		
2.36 (60)	Ø .22 Ø (5.5)	.18 (4.5)		

Inches (mm)

P2LAX 5/2 & 5/3 Single & Double Operators – IEM Aluminum Bar Manifold

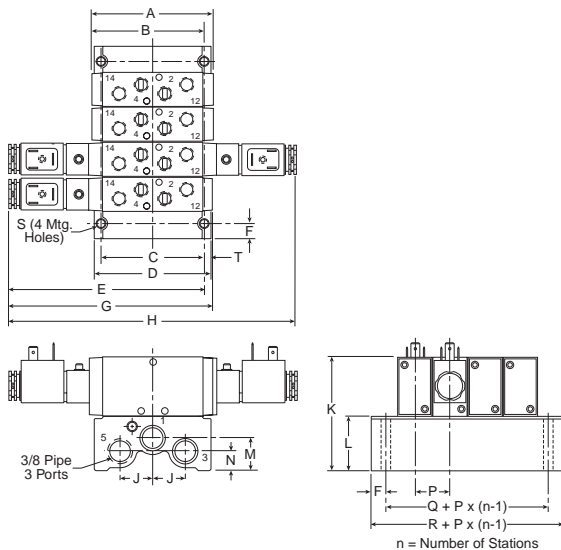

**P2LAX 5/2 & 5/3
 IEM Aluminum bar manifold**

A	B	C	D	E
3.19 (81)	2.97 (76)	2.76 (70)	3.12 (79)	5.26 (134)
F	G	H	J	K
41 (10.5)	5.47 (139)	7.72 (196)	.87 (22)	3.11 (79)
L	M	N	P	Q
1.54 (39)	.87 (22)	.52 (13.2)	.93 (23.5)	1.56 (39.5)
R	S	T		
2.36 (60)	Ø .22 Ø (5.5)	.18 (4.5)		

Inches (mm)

C

Inline Valves

Viking Lite

Viking Xtreme

"B" Series

Air Saver Unit

ADEX Series

"N" Series



For inventory, lead time, and kit lookup, visit www.pdnplu.com

C33

Parker Hannifin Corporation
 Pneumatic Division
 Richland, Michigan
www.parker.com/pneumatics

P2LBX 3/2 Single & Double Operators – Solenoid

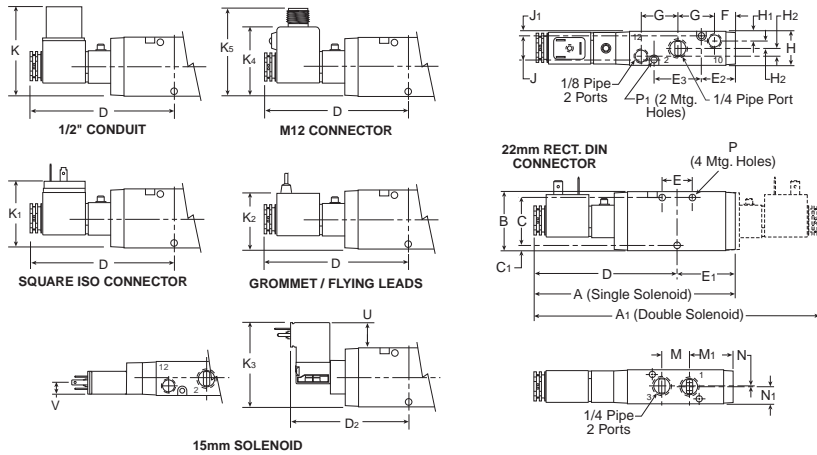

P2LBX 3/2 (solenoid)

A	A1	B	C	C1	D
5.35 (136)	7.60 (193)	1.57 (40)	1.26 (32)	.16 (4)	3.80 (96.5)
D2	E	E1	E2	E3	F
3.02 (76.8)	.79 (20)	1.54 (39)	.51 (13)	1.26 (32)	.55 (14)
G	H	H1	H2	J	J1
.98 (25)	.87 (22)	.26 (6.6)	.18 (4.5)	.65 (16.5)	.11 (2.9)
K	K1	K2	K3	K4	K5
2.36 (60)	1.61 (41)	1.50 (38)	2.24 (57)	1.63 (41.3)	2.10 (53.3)
M	M1	N	N1	P	P1
.79 (20)	1.14 (29)	.02 (0.5)	.42 (11)	Ø .17 Ø (4.3)	Ø .12 Ø (3.1)
U	V				
0.81 (20.5)	0.29 (7.5)				

Inches (mm)

P2LBX 3/2 Single & Double Operators – Remote Air Pilot

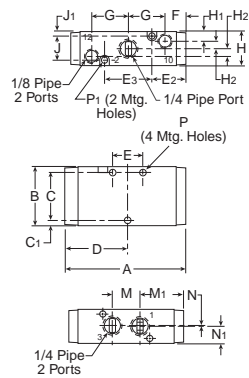

P2LBX 3/2 (remote air pilot)

A	B	C	C1	D	E
3.08 (78)	1.57 (40)	1.26 (32)	.16 (4)	1.54 (39)	.79 (20)
E2	E3	F	G	H	H1
.51 (13)	1.26 (32)	.55 (14)	.98 (25)	.87 (22)	.26 (6.6)
H2	J	J1	M	M1	N
.18 (4.5)	.65 (16.5)	.11 (2.9)	.79 (20)	1.14 (29)	.02 (0.5)
N1	P	P1			
.42 (11)	Ø .17 Ø (4.3)	Ø .12 Ø (3.1)			

Inches (mm)

P2LBX 5/2 & 5/3 Single & Double Operators – Solenoid

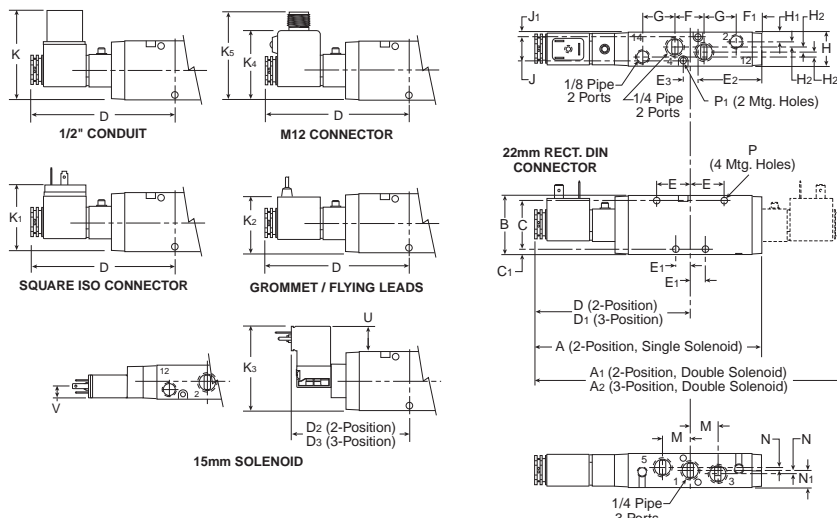

P2LBX 5/2 & 5/3 (solenoid)

A	A1	A2	B	C	C1
6.14 (156)	8.39 (213)	9.23 (235)	1.57 (40)	1.26 (32)	.16 (4)
D	D1	D2	D3	E	E1
4.21 (107)	4.64 (118)	3.48 (88.3)	3.92 (99.6)	.91 (23)	.39 (10)
E2	E3	F	F1	G	H
1.73 (44)	.39 (10)	.79 (20)	.67 (17)	.87 (22)	.87 (22)
H1	H2	J	J1	K	K1
.26 (6.6)	.12 (3)	.65 (16.5)	.12 (3)	2.36 (60)	1.61 (41)
K2	K3	K4	K5	M	N
1.50 (38)	2.24 (57)	1.70 (43.3)	2.10 (53.3)	.79 (20)	.08 (2)
N1	P	P1	U	V	
.43 (11)	Ø .17 Ø (4.3)	Ø .12 Ø (3.1)	0.81 (20.5)	0.29 (7.5)	

Inches (mm)

C
Inline Valves
Viking
Lite
Viking
Extreme
Series
"B"
Air Saver
Unit
Series
ADEX
Series
"N"



For inventory, lead times, and kit lookup, visit www.pdnplu.com

P2LBX 5/2 & 5/3 Single & Double Operators – Remote Air Pilot

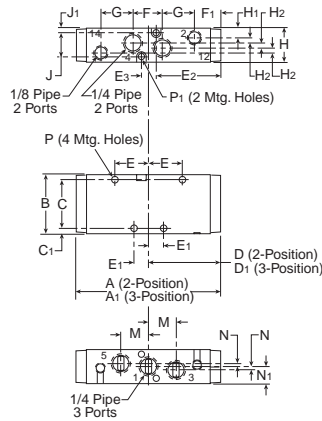

P2LBX 5/2 & 5/3 (remote air pilot)

A	A1	B	C	C1	D
3.95 (100)	4.61 (117)	1.57 (40)	1.26 (32)	.16 (4)	1.93 (49)
D1	E	E1	E2	E3	F
2.28 (58)	.91 (23)	.39 (10)	1.73 (44)	.39 (10)	.79 (20)
F1	G	H	H1	H2	J
.67 (17)	.87 (22)	.8 (22)	.26 (6.6)	.12 (3)	.65 (16.5)
J1	K	M	N	N1	P
.11 (2.8)	2.90 (74)	.79 (20)	.08 (2)	.43 (11)	Ø .17 Ø (4.3)
P1					
Ø .12 Ø (3.1)					

Inches (mm)

P2LBX 5/2 Single & Double Operators – Solenoid NAMUR

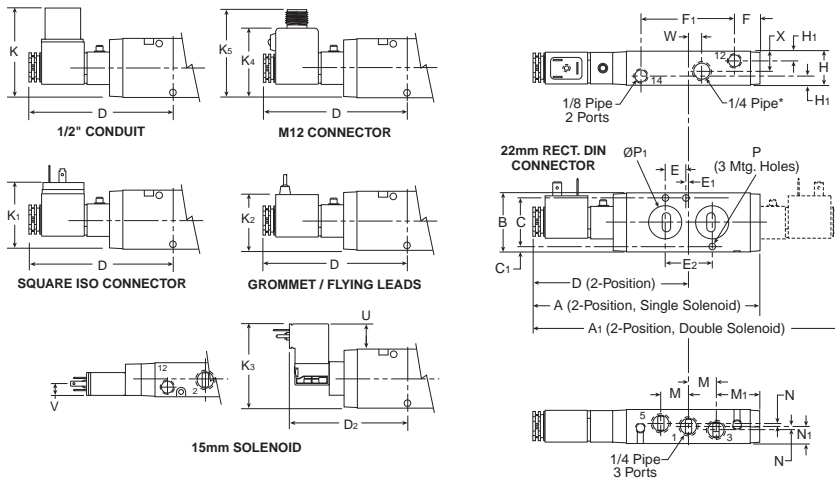

P2LBX 5/2 (NAMUR)

A	A1	B	C	C1	D
6.15 (156)	8.39 (213)	1.57 (40)	1.26 (32)	.16 (4)	4.21 (107)
D2	E	E1	E2	F	F1
3.48 (88.3)	.47 (12)	.08 (2)	.94 (24)	.67 (17)	2.52 (64)
K	K1	K2	K3	K4	K5
2.36 (60)	1.61 (41)	1.50 (38)	2.24 (57)	1.70 (43.3)	2.10 (53.3)
H	H1	M	M1	N	N1
.87 (22)	.26 (6.6)	.79 (20)	1.14 (29)	.08 (2)	.43 (11)
P	P1	U	V	W	X
Ø .22 Ø (5.5)	Ø .76 Ø (19.4)	0.81 (20.5)	0.29 (7.5)	0.39 (10)	0.50 (12.6)

Inches (mm)

* Valve includes 1/4 pipe plug, o-rings and mounting bolts.

C

Inline Valves

Viking Lite

Viking Extreme

"B" Series

Air Saver Unit

ADEX Series

"N" Series

Dimensional Data

P2LBX 3/2 Single & Double Operators – IEM Aluminum Bar Manifold

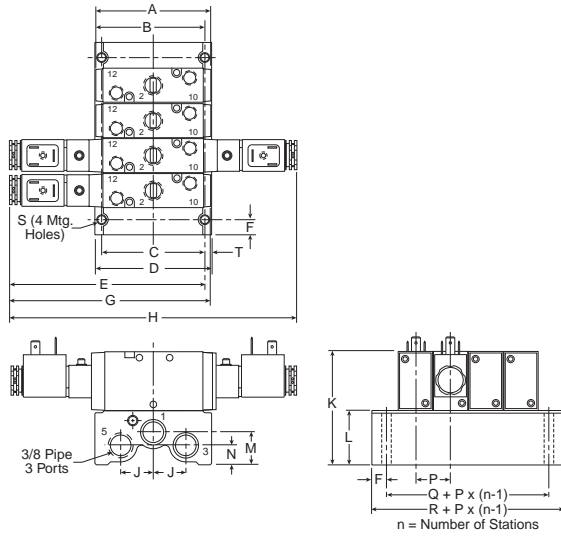

**P2LBX 3/2
IEM Aluminum bar manifold**

A	B	C	D	E
3.86 (78)	2.91 (74)	2.76 (70)	3.12 (79)	5.17 (131)

F	G	H	J	K
.40 (10.2)	5.33 (136)	7.6 (193)	.87 (22)	3.11 (79)

L	M	N	P	Q
1.47 (37)	.87 (22)	.52 (13.2)	.93 (23.5)	1.56 (39.6)

R	S	T
2.36 (60)	Ø .22 (5.5)	.18 (4.6)

Inches (mm)

P2LBX 5/2 & 5/3 Single & Double Operators – IEM Aluminum Bar Manifold

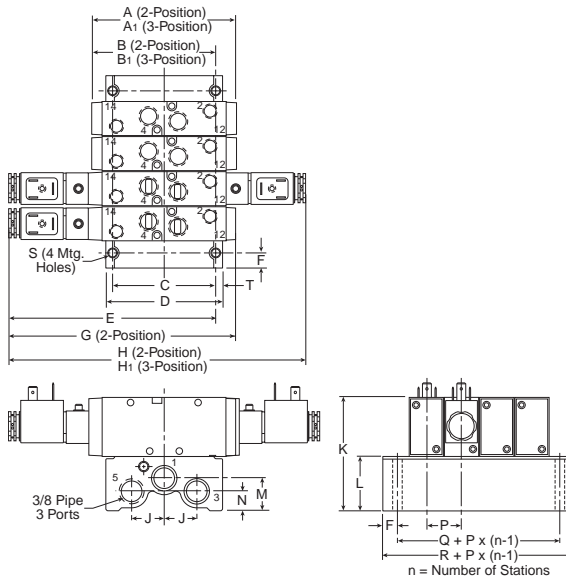

**P2LBX 5/2 & 5/3
IEM Aluminum bar manifold**

A	A1	B	B1	C
3.86 (98)	4.70 (120)	3.42 (84)	3.73 (95)	2.76 (70)

D	E	F	G	H
3.12 (79)	5.59 (142)	.40 (10.2)	6.14 (156)	8.39 (213)

H1	J	K	L	M
9.23 (235)	.87 (22)	3.11 (79)	1.47 (37)	.87 (22)

N	P	Q	R	S
.52 (13.2)	.93 (23.5)	1.56 (39.6)	2.36 (60)	Ø .22 (5.5)

T
.18 (4.6)

Inches (mm)

C

Inline Valves

Viking Lite

Viking Xtreme

"B" Series

Air Saver Unit

ADEX Series

"N" Series



For inventory, lead times, and kit lookup, visit www.pdnplu.com

P2LCX 3/2 Single & Double Operators – Solenoid

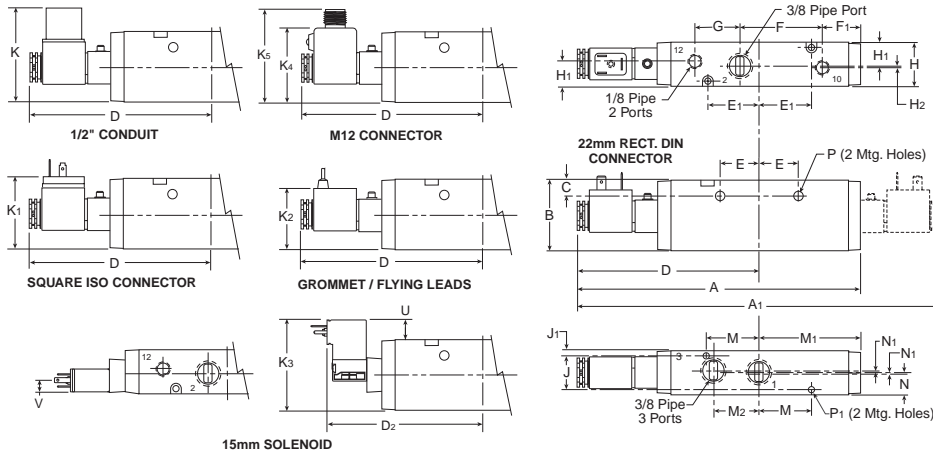

P2LCX 3/2 (solenoid)

A	A₁	B	C	D
7.66 (194.5)	9.80 (249)	1.89 (48)	.43 (11)	4.90 (124.5)
D₂	E	E₁	F	F₁
4.17 (105.8)	1.04 (26.5)	1.40 (35.5)	2.24 (57)	1.02 (26)
G	H	H₁	H₂	J
1.22 (31)	1.18 (30)	.67 (17)	.02 (0.5)	.91 (23)
J₁	K	K₁	K₂	K₃
.14 (3.5)	2.52 (64)	1.77 (45)	1.65 (42)	2.41 (61.3)
K₄	K₅	M	M₁	M₂
1.78 (45.3)	2.26 (57.3)	1.40 (35.5)	2.76 (70)	1.18 (30)
N	N₁	P	P₁	U
.55 (14)	.04 (1)	Ø .27 (6.9)	Ø .17 (4.4)	0.52 (13.3)
V				
0.65 (7.5)				

Inches (mm)

P2LCX 3/2 Single & Double Operators – Remote Air Pilot

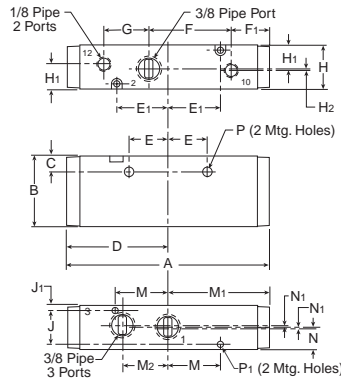

P2LCX 3/2 (remote air pilot)

A	B	C	D	E
5.51 (140)	1.89 (48)	.43 (11)	2.76 (70)	1.04 (26.5)
E₁	F	F₁	G	H
1.40 (35.5)	2.24 (57)	1.02 (26)	1.22 (31)	1.18 (30)
H₁	H₂	J	J₁	M
.67 (17)	.02 (0.5)	.91 (23)	.14 (3.5)	1.40 (35.5)
M₁	M₂	N	N₁	P
2.76 (70)	1.18 (30)	.55 (14)	.04 (1)	Ø .27 (6.9)
P₁				
Ø .17 (4.4)				

Inches (mm)

C

Inline Valves

Viking Lite

Viking Extreme

"B" Series

Air Saver Unit

ADEX Series

"N" Series

P2LCX 5/2 & 5/3 Single & Double Operators – Solenoid

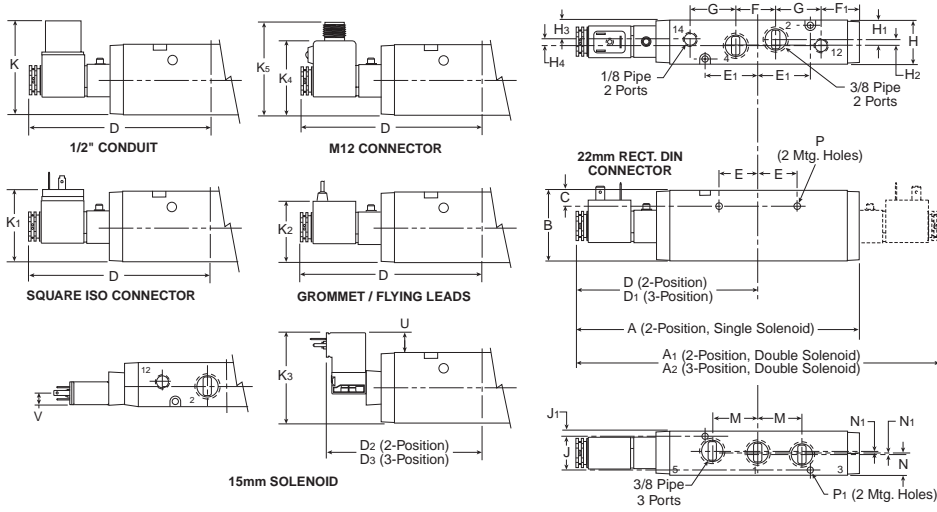

P2LCX 5/2 & 5/3 (solenoid)

A	A₁	A₂	B	C
7.68 (195)	9.84 (250)	10.71 (272)	1.89 (48)	.43 (11)
D	D₁	D₂	D₃	E
4.92 (125)	5.35 (136)	4.17 (105.8)	4.61 (117.2)	1.04 (26.5)
E₁	F	F₁	G	H
1.40 (35.5)	1.06 (27)	1.02 (26)	1.22 (31)	1.18 (30)
H₁	H₂	H₃	H₄	J
.53 (13.5)	.12 (3)	.51 (13)	.16 (4)	.91 (23)
J₁	K	K₁	K₂	K₃
.14 (3.5)	2.52 (64)	1.77 (45)	1.65 (42)	2.41 (61.3)
K₄	K₅	M	N	N₁
1.78 (45.3)	2.26 (57.3)	1.18 (30)	.55 (14)	.04 (1)
P	P₁	U	V	
∅ .27 (6.9)	∅ .17 (4.4)	0.52 (13.3)	0.29 (7.5)	

Inches (mm)

P2LCX 5/2 & 5/3 Single & Double Operators – Remote Air Pilot

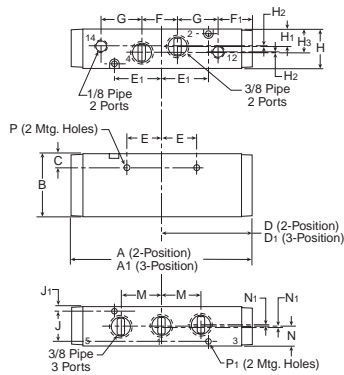

P2LCX 5/2 & 5/3 (remote air pilot)

A	A₁	B	C	D	D₁
5.51 (140)	6.38 (162)	1.89 (48)	.43 (11)	2.76 (70)	3.18 (81)
E	E₁	F	F₁	G	H
1.04 (26.5)	1.40 (35.5)	1.06 (27)	1.02 (26)	1.22 (31)	1.18 (30)
H₁	H₂	H₃	J	J₁	M
.51 (13)	.02 (0.5)	.12 (3)	.91 (23)	.14 (3.5)	1.18 (30)
N	N₁	P	P₁		
.55 (14)	.04 (1)	∅ .27 (6.9)	∅ .17 (4.4)		

Inches (mm)

P2LCX 3/2 Single & Double Operators – IEM Aluminum Bar Manifold

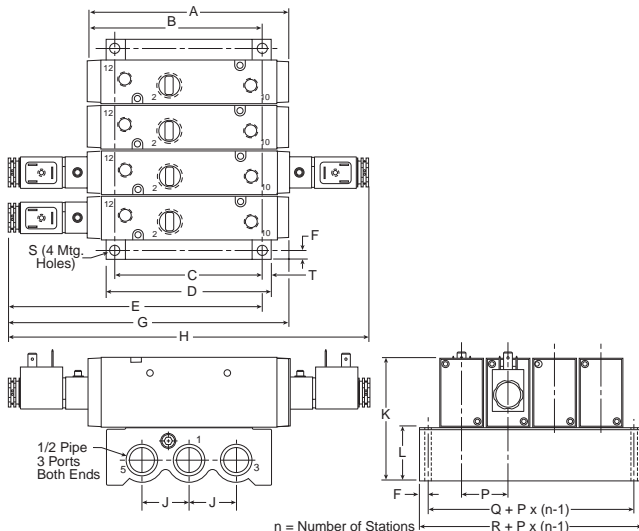

P2LCX 3/2 IEM Aluminum bar manifold

A	B	C	D	E	F
5.51 (140)	4.96 (126)	3.94 (100)	4.41 (112)	7.11 (180.5)	.24 (6)
G	H	J	K	L	P
7.66 (194.5)	9.80 (249)	1.26 (32)	3.43 (87)	1.54 (39)	1.24 (31.5)
Q	R	S	T		
1.77 (45)	2.24 (57)	∅ .26 (6.5)	.24 (6)		

Inches (mm)

P2LCX 5/2 & 5/3 Single & Double Operators – IEM Aluminum Bar Manifold

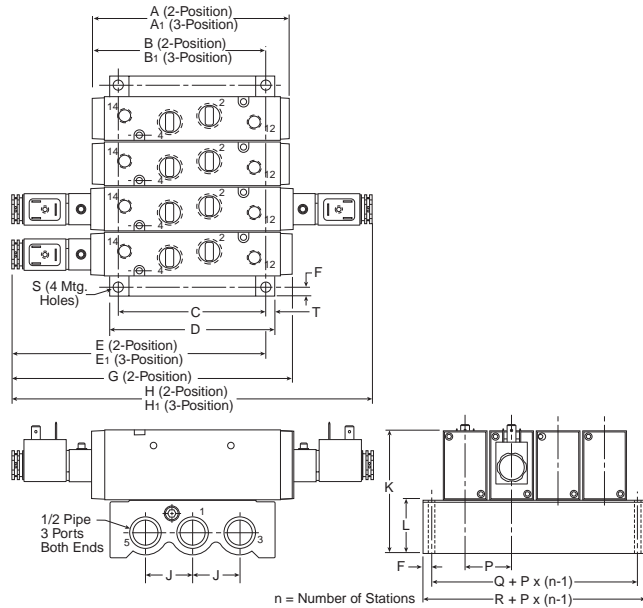

**P2PCX 5/2 & 5/3
 IEM Aluminum bar manifold**

A	A ₁	B	B ₁	C
5.51 (140)	6.38 (162)	4.72 (120)	5.16 (131)	3.94 (100)
D	E	E ₁	F	G
4.41 (112)	6.89 (170)	7.13 (181)	.24 (6)	7.68 (195)
H	H ₁	J	K	L
9.84 (250)	10.71 (272)	1.26 (32)	3.43 (87)	1.54 (39)
P	Q	R	S	T
1.24 (31.5)	1.77 (45)	2.24 (57)	Ø .26 (6.5)	.24 (6)

Inches (mm)

P2LDX 3/2 Single & Double Operators – Solenoid

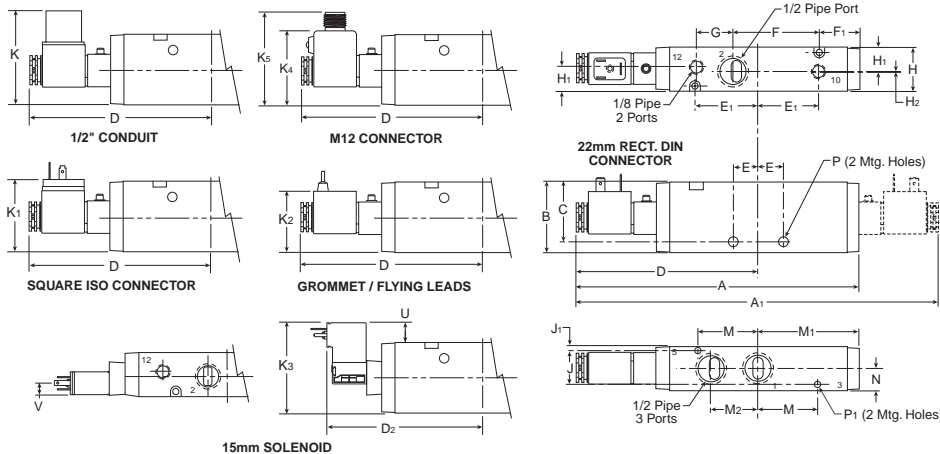

P2LDX 3/2 (solenoid)

A	A ₁	B	C	D
7.66 (194.5)	9.80 (249)	1.89 (48)	1.59 (40.5)	4.90 (124.5)
D ₂	E	E ₁	F	F ₁
4.17 (105.8)	.67 (17)	1.65 (42)	2.36 (60)	1.08 (27.5)
G	H	H ₁	H ₂	J
.98 (25)	1.18 (30)	.67 (17)	.02 (0.5)	.91 (23)
J ₁	K	K ₁	K ₂	K ₃
.14 (3.5)	2.52 (64)	1.77 (45)	1.65 (42)	2.41 (61.3)
K ₄	K ₅	M	M ₁	M ₂
1.78 (45.3)	2.26 (57.3)	1.65 (42)	2.76 (70)	1.30 (33)
N	P	P ₁	U	V
.59 (15)	Ø .26 (6.6)	Ø .17 (4.4)	0.65 (16.5)	0.29 (7.5)

Inches (mm)

C

Inline Valves

Viking
Lite

Viking
Extreme

"B"
Series

Air Saver
Unit

ADEX
Series

"N"
Series

P2LDX 3/2 Single & Double Operators – Remote Air Pilot

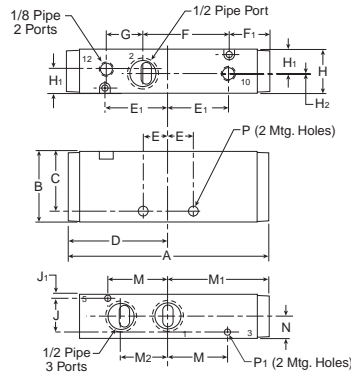

P2LDX 3/2 (remote air pilot)

A	B	C	D	E
5.51 (140)	1.89 (48)	1.59 (40.5)	2.76 (70)	.67 (17)
E ₁	F	F ₁	G	H
1.65 (42)	2.36 (60)	1.08 (27.5)	.98 (25)	1.18 (30)
H ₁	H ₂	J	J ₁	M
.67 (17)	.02 (0.5)	.91 (23)	.14 (3.5)	1.65 (42)
M ₁	M ₂	N	P	P ₁
2.76 (70)	1.30 (33)	.59 (15)	Ø .26 Ø (6.6)	Ø .17 Ø (4.4)

Inches (mm)

P2LDX 5/2 & 5/3 Single & Double Operators – Solenoid

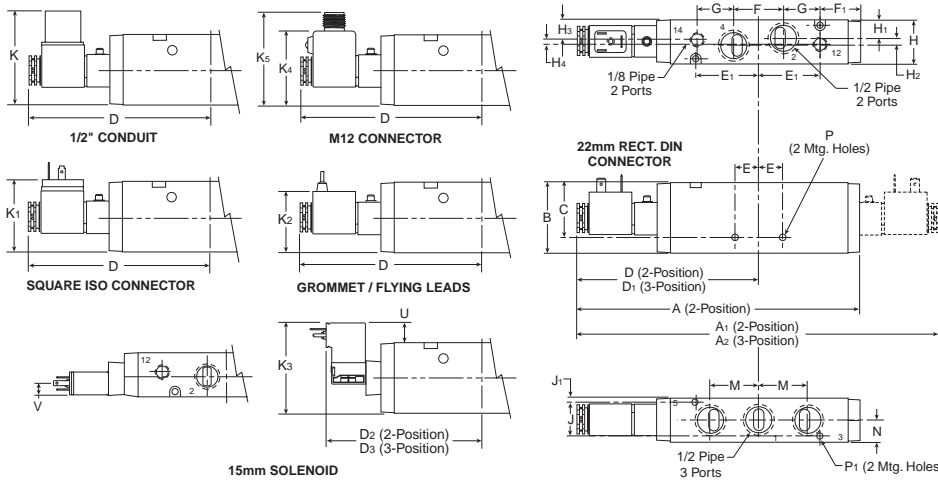

P2LDX 5/2 & 5/3 (solenoid)

A	A ₁	A ₂	B	C
7.67 (195)	9.84 (250)	10.7 (272)	1.89 (48)	1.59 (40.5)
D	D ₁	D ₂	D ₃	E
4.92 (125)	5.79 (147)	4.17 (105.3)	4.61 (117.2)	.67 (17)
E ₁	F	F ₁	G	H
1.65 (42)	1.34 (34)	1.10 (28)	.98 (25)	1.18 (30)
H ₁	H ₂	H ₃	H ₄	J
.49 (12.5)	.20 (5)	.51 (13)	.16 (4)	.91 (23)
J ₁	K	K ₁	K ₂	K ₃
.14 (3.5)	2.52 (64)	1.77 (45)	1.65 (42)	2.41 (61.3)
K ₄	K ₅	M	N	P
1.78 (45.3)	2.26 (57.3)	1.30 (33)	.59 (15)	Ø .26 Ø (6.6)
P ₁	U	V		
Ø .17 Ø (4.4)	0.52 (13.3)	0.29 (7.5)		

Inches (mm)

P2LDX 5/2 & 5/3 Single & Double Operators – Remote Pilot

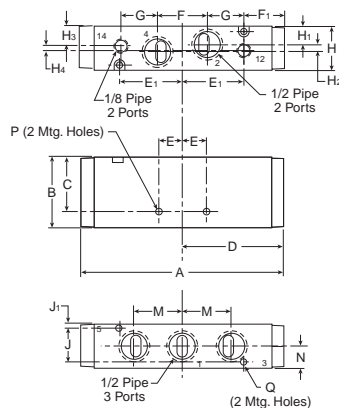

P2LDX 5/2 & 5/3 (remote)

A	B	C	D	E
5.47 (139)	1.89 (48)	1.59 (40.5)	2.63 (67)	.67 (17)
E ₁	F	F ₁	G	H
1.65 (42)	1.34 (34)	1.08 (27.5)	.98 (25)	1.18 (30)
H ₁	H ₂	H ₃	H ₄	J
.49 (12.5)	.20 (5)	.51 (13)	.16 (4)	.91 (23)
J ₁	P	M	N	Q
.14 (3.5)	Ø .26 Ø (6.6)	1.29 (32.7)	.59 (15)	Ø .17 Ø (4.4)

Inches (mm)

C

Inline Valves

Viking Lite

Viking Extreme

"B" Series

Air Saver Unit

ADEX Series

"N" Series



For inventory, lead times, and kit lookup, visit www.pdnplu.com

Features

B Series

B Series

B Series, an exceptional performing industrial valve in a compact size with an enhanced flow range.

Available in solenoid pilot operated and remote air pilot models. The B series features Parker's proven WCS (Wear Compensating Seal) system ensuring long life and fast response.

Ports

- B3: 1/8, 1/4 inch – 0.75 Cv
- B5: 1/4, 3/8 inch – 1.40 Cv
- B6: 3/8 inch – 2.50 Cv
- B7: 1/2 inch – 5.90 Cv
- B8: 3/4 inch – 7.00 Cv

Mounting

- Inline
- Subbase
- IEM stackable base
- IEM aluminum bar
- 5-port subbase aluminum bar

Solenoids

- 1.2 W – 15mm, 3-pin EN175301-803
- 2.5 to 7.3 watt - conduit, grommet, 22mm & 30mm, 3-pin DIN (433650)
- 12VDC to 240VAC
- Female DIN electrical connectors

Certification / Approval

- Approved to be CE marked
- IP65 rated
- CSA, C/US†

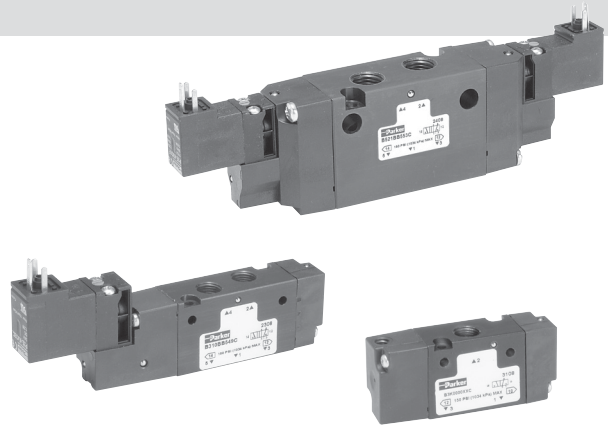

Operating information

Operating pressure:	Vacuum to 145 PSIG (Vacuum to 10 bar)
Minimum:	See chart below
CSA-NRTL/C:	See chart below
Operating temperature:	5°F to 120°F (-15°C to 49°C)

Material specifications

Body	Anodized aluminum
End caps	Nylon polymer - 33% glass filled
Seals	Nitrile
Solenoid	Polyamide
Spool	Aluminum

Minimum operating pressure

Operator / function	Internal pilot	Minimum PSIG (kPa)				
		B3	B5	B6	B7	B8
1. G. H	Single solenoid - air return					
2. A. J. S	Double solenoid	20 (138)	20 (138)	20 (138)	35 (241)	35 (241)
3. K. L	Single remote pilot - air return					
4. M	Double remote pilot	Vacuum				
5. 6. 7	Double solenoid - APB, CE, PC	30 (207)	30 (207)	30 (207)	45 (310)	45 (310)
8. 9. 0	Double remote pilot - APB, CE, PC	Vacuum				
E. V. W	Single solenoid - air return / spring assist	35 (241)	35 (241)	35 (241)	35 (241)	35 (241)
F. X. Y	Single remote pilot - air return / spring assist					
External pilot**						
All	"B" series	Vacuum				

* External Pilot Pressure / Remote Pilot Signal 35-145 PSIG (241-1000 kPa).

† Not Available with B3 Dual 3/2.

‡ CSA-NRTL/C operating pressure

Note: For CSA-NRTL/C approved solenoid valves – insert an 'L' at the end of the valve part number.

Valve	Maximum PSIG (kPa)
B3	120 (827)
B5 & B6	145 (1000)*§
B7 & B8	145 (1000)*†

* Enclosure Option E is CSA / FM approved at source. For certification of valve / solenoid assembly, consult factory.

† Not Available with Enclosure 5

§ Not available with Enclosures 0. 5 & X

C

Inline Valves

Viking Lite

Viking Extreme

"B" Series

Air Saver Unit

ADEX Series

"N" Series



For inventory, lead time, and kit lookup, visit www.pdnplu.com

Common Part Numbers

Single Solenoid, 3-way, 2-position, NC

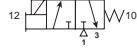

Symbol	Port size	Cv	Voltage	Valve type	Part number
	1/8"	0.75 Cv	120VAC 24VDC	B3 Inline	B3G0BB553C B3G0BB549C
	1/4"	1.4 Cv	120VAC 24VDC	B5 Inline	B5G1BB553C B5G1BB549C
	3/8"	1.4 Cv	120VAC 24VDC	B5 Inline	B5G2BB553C B5G2BB549C
	3/8"	2.7 Cv	120VAC 24VDC	B6 Inline	B6V2BB553A B6V2BB549A
	1/2"	5.9 Cv	120VAC 24VDC	B7 Inline	B7V3BB553A B7V3BB549A
	3/4"	7.0 Cv	120VAC 24VDC	B8 Inline	B8V4BB553A B8V4BB549A

B3 shown, 3-Pin DIN 43650C electrical connection. Non-locking flush override.

Single Solenoid, 4-way, 2-position

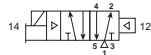

Symbol	Port size	Cv	Voltage	Valve type	Part number
	1/8"	0.75 Cv	120VAC 24VDC	B3 Inline	B310BB553C B310BB549C
	1/4"	1.4 Cv	120VAC 24VDC	B5 Inline	B511BB553C B511BB549C
	3/8"	1.4 Cv	120VAC 24VDC	B5 Inline	B512BB553C B512BB549C
	3/8"	2.7 Cv	120VAC 24VDC	B6 Inline	B612BB553A B612BB549A
	1/2"	5.9 Cv	120VAC 24VDC	B7 Inline	B713BB553A B713BB549A
	3/4"	7.0 Cv	120VAC 24VDC	B8 Inline	B814BB553A B814BB549A
	Less base	0.65 Cv	120VAC 24VDC	B3 Subbase	B31VBB553C B31VBB549C

B3 shown, 3-Pin DIN 43650C electrical connection. Non-locking flush override.

Double Solenoid, 4-way, 2-position



Symbol	Port size	Cv	Voltage	Valve type	Part number
	1/8"	0.75 Cv	120VAC 24VDC	B3 Inline	B320BB553C B320BB549C
	1/4"	1.4 Cv	120VAC 24VDC	B5 Inline	B521BB553C B521BB549C
	3/8"	1.4 Cv	120VAC 24VDC	B5 Inline	B522BB553C B522BB549C
	3/8"	2.7 Cv	120VAC 24VDC	B6 Inline	B622BB553A B622BB549A
	1/2"	5.9 Cv	120VAC 24VDC	B7 Inline	B723BB553A B723BB549A
	3/4"	7.0 Cv	120VAC 24VDC	B8 Inline	B824BB553A B824BB549A
	Less base	0.65 Cv	120VAC 24VDC	B3 Subbase	B32VBB553C B32VBB549C

B5 shown, 3-Pin DIN 43650C electrical connection. Non-locking flush override.

ANSI / (NFPA) T3.21.3-1990 standard for Cv measurement.

Most popular.



For inventory, lead times, and kit lookup, visit www.pdnplu.com

Double Solenoid, 4-way, 3-position, APB

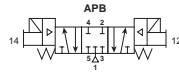

Symbol	Port size	Cv	Voltage	Valve type	Part number
	1/8"	0.60 Cv	120VAC 24VDC	B3 Inline	B350BB553C B350BB549C
	1/4"	1.1 Cv	120VAC 24VDC	B5 Inline	B551BB553C B551BB549C
	3/8"	1.1 Cv	120VAC 24VDC	B5 Inline	B552BB553C B552BB549C
	3/8"	2.1 Cv	120VAC 24VDC	B6 Inline	B652BB553A B652BB549A
	1/2"	5.7 Cv	120VAC 24VDC	B7 Inline	B753BB553A B753BB549A
	3/4"	6.6 Cv	120VAC 24VDC	B8 Inline	B854BB553A B854BB549A
	Less base	0.50 Cv	120VAC 24VDC	B3 Subbase	B35VBB553C B35VBB549C

B5 shown, 3-Pin DIN 43650C electrical connection. Non-locking flush override.

Double Solenoid, 4-way, 3-position, CE

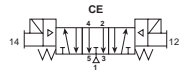

Symbol	Port size	Cv	Voltage	Valve type	Part number
	1/8"	0.60 Cv	120VAC 24VDC	B3 Inline	B360BB553C B360BB549C
	1/4"	1.1 Cv	120VAC 24VDC	B5 Inline	B561BB553C B561BB549C
	3/8"	1.1 Cv	120VAC 24VDC	B5 Inline	B562BB553C B562BB549C
	3/8"	2.1 Cv	120VAC 24VDC	B6 Inline	B662BB553A B662BB549A
	1/2"	5.7 Cv	120VAC 24VDC	B7 Inline	B763BB553A B763BB549A
	3/4"	6.6 Cv	120VAC 24VDC	B8 Inline	B864BB553A B864BB549A
	Less base	0.50 Cv	120VAC 24VDC	B3 Subbase	B36VBB553C B36VBB549C

B5 shown, 3-Pin DIN 43650C electrical connection. Non-locking flush override.

Double Solenoid, 4-way, 3-position, PC

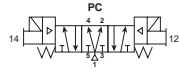

Symbol	Port size	Cv	Voltage	Valve type	Part number
	1/8"	0.60 Cv	120VAC 24VDC	B3 Inline	B370BB553C B370BB549C
	1/4"	1.1 Cv	120VAC 24VDC	B5 Inline	B571BB553C B571BB549C
	3/8"	1.1 Cv	120VAC 24VDC	B5 Inline	B572BB553C B572BB549C
	3/8"	2.1 Cv	120VAC 24VDC	B6 Inline	B672BB553A B672BB549A
	1/2"	5.7 Cv	120VAC 24VDC	B7 Inline	B773BB553A B773BB549A
	3/4"	6.6 Cv	120VAC 24VDC	B8 Inline	B874BB553A B874BB549A
	Less base	0.50 Cv	120VAC 24VDC	B3 Subbase	B37VBB553C B37VBB549C

B5 shown, 3-Pin DIN 43650C electrical connection. Non-locking flush override.

ANSI / (NFPA) T3.21.3-1990 standard for Cv measurement.

 Most popular.



For inventory, lead time, and kit lookup, visit www.pdnplu.com

Single Remote Pilot, 3-way, 2-position, NC

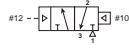

B3 Shown, M5 remote pilot ports

Symbol	Port size	Cv	Valve type	Part number
	1/8"	0.75 Cv	B3 Inline, remote pilot	B3K000XXC
	1/4"	1.4 Cv	B5 Inline, remote pilot	B5K1000XXC
	3/8"	1.4 Cv	B5 Inline, remote pilot	B5K2000XXC
	3/8"	2.7 Cv	B6 Inline, remote pilot	B6X2000XXA
	1/2"	5.9 Cv	B7 Inline, remote pilot	B7X3000XXA
	3/4"	7.0 Cv	B8 Inline, remote pilot	B8X4000XXA

Single Remote Pilot, 4-way, 2-position



B5 Shown, M5 remote pilot ports

Symbol	Port size	Cv	Valve type	Part number
	1/8"	0.75 Cv	B3 Inline, remote pilot	B330000XXC
	1/4"	1.4 Cv	B5 Inline, remote pilot	B531000XXC
	3/8"	1.4 Cv	B5 Inline, remote pilot	B532000XXC
	3/8"	2.7 Cv	B6 Inline, remote pilot	B632000XXA
	1/2"	5.9 Cv	B7 Inline, remote pilot	B733000XXA
	3/4"	7.0 Cv	B8 Inline, remote pilot	B834000XXA
	Less base	0.65 Cv	B3 Subbase, remote pilot	B33V000XXC

Double Remote Pilot, 4-way, 2-position



B5 Shown, M5 remote pilot ports

Symbol	Port size	Cv	Valve type	Part number
	1/8"	0.75 Cv	B3 Inline, remote pilot	B340000XXC
	1/4"	1.4 Cv	B5 Inline, remote pilot	B541000XXC
	3/8"	1.4 Cv	B5 Inline, remote pilot	B542000XXC
	3/8"	2.7 Cv	B6 Inline, remote pilot	B642000XXA
	1/2"	5.9 Cv	B7 Inline, remote pilot	B743000XXA
	3/4"	7.0 Cv	B8 Inline, remote pilot	B844000XXA
	Less base	0.65 Cv	B3 Subbase, remote pilot	B34V000XXC

Double Remote Pilot, 4-way, 3-position, APB

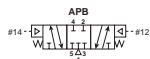

B5 Shown, M5 remote pilot ports

Symbol	Port size	Cv	Valve type	Part number
	1/8"	0.60 Cv	B3 Inline, remote pilot	B380000XXC
	1/4"	1.1 Cv	B5 Inline, remote pilot	B581000XXC
	3/8"	1.1 Cv	B5 Inline, remote pilot	B582000XXC
	3/8"	2.1 Cv	B6 Inline, remote pilot	B682000XXA
	1/2"	5.7 Cv	B7 Inline, remote pilot	B783000XXA
	3/4"	6.6 Cv	B8 Inline, remote pilot	B884000XXA
	Less Base	0.50 Cv	B3 Subbase, remote pilot	B38V000XXC

ANSI / (NFPA) T3.21.3-1990 standard for Cv measurement.

Most popular.



For inventory, lead times, and kit lookup, visit www.pdnplu.com

B3 Series

B3 1 0 B B 5 49 - C

Basic series	
B3 series	B3

Engineering level	
C	Current
CL	CSA Current

Operator Function	
3-way	
Single solenoid, 2-position NC - air return	G
Single solenoid, 2-position NO - air return	H
Double solenoid, 2-position	J
Single remote pilot, 2-position NC - air return	K
Single remote pilot, 2-position NO - air return	L
Double remote pilot, 2-position	M
Single solenoid, 2-position NC - air return / spring assist	V
Single solenoid, 2-position NO - air return / spring assist	W
Single remote pilot, 2-position NC - air return / spring assist	X
Single remote pilot, 2-position NO - air return / spring assist	Y
4-way	
Single solenoid, 2-position - air return	1
Double solenoid, 2-position	2
Single remote pilot, 2-position - air return	3
Double remote pilot, 2-position	4
Double solenoid, 3-position - APB	5
Double solenoid, 3-position - CE	6
Double solenoid, 3-position - PC	7
Double remote pilot, 3-position - APB	8
Double remote pilot, 3-position - CE	9
Double remote pilot, 3-position - PC	0
Single solenoid, 2-position - air return / spring assist	E
Single remote pilot, 2-position - air return / spring assist	F

Options	
Blank	None
02	Solenoid rotated 180° - pins down

	Voltage [§]		
	AC		DC
	60Hz	50Hz	
42	24	22	
45			12
49			24
53	120	110	
57	240	230	
XX	Remote pilot - M5 or valve less 15mm solenoid		
YY	Remote pilot - 5/32" (4mm) tube		

Enclosure / lead length	
0	None, remote pilot valve
5	15mm 3-pin DIN 43650C (male only)
X	Valve less 15mm solenoid

Overrides [§]	
0	None, remote pilot valve
B	Flush - non-locking
C	Flush - locking
D	Extended - non-locking
E	Extended - locking
X	Valve less 15mm solenoid

Port size / thread type	
3-way	
1/8" NPT inline	0*
1/8" BSPP "G" inline	5*
4-way	
1/8" NPT inline	0*
1/8" BSPP "G" inline	5*
1/4" NPT subbase	H†
1/8" NPT face mount	T**
Subbase valve less base	V‡

* Available for use on IEM Manifolds.
 ** 4-way only.
 † Subbase valves available for 4-way valves only, included base.

Pilot source / pilot exhaust	
0	None, remote pilot valve
B†	Internal - port #1 / vented
E*	Dual pressure - port #3 / vented
K†	External - body / tapped M5
X†	External - manifold / vented

* Not available for 3-way Valves.
 † Not available for Remote Pilot Valves.
 ‡ See Pilot Source Note below.

§ Enclosure '5'
 - Override / Voltage Availability

S - Standard
 O - Option

Voltage code	Override code			
	B	C	D	E
42	O	O	-	-
45	O	O	-	-
49	S	S	O	O
53	S	S	O	O
57	O	O	-	-
Voltage code	"02" Option			
	B	C	D	E
42	O	O	-	-
45	O	O	-	-
49	S	S	O	O
53	S	S	O	O
57	O	O	-	-

C

Inline Valves

Viking Lite

Viking Extreme

"B" Series

Air Saver Unit

ADEX Series

"N" Series

Pilot Source 'X'
 External-Manifold / Vented

INLINE & SUBBASE Valves -
 Only used IF an IEM or 5-Ported Subbase Aluminum Bar Manifold requires a common external pilot signal through the manifold for low pressure / vacuum applications OR when used with Sandwich Regulators.

Most popular.



For inventory, lead time, and kit lookup, visit www.pdnplu.com

B5 Series

B5 1 1 B B 5 49 - C

Basic series	
B5 series	B5

Engineering level	
C	Current
CL	CSA Current

Operator function	
3-way	
Single solenoid, 2-position NC - air return	G
Single solenoid, 2-position NO - air return	H
Double solenoid, 2-position	J
Single remote pilot, 2-position NC - air return	K*
Single remote pilot, 2-position NO - air return	L*
Double remote pilot, 2-position	M*
Single solenoid, 2-position NC - air return / spring assist	V
Single solenoid, 2-position NO - air return / spring assist	W
Single remote pilot, 2-position NC - air return / spring assist	X*
Single remote pilot, 2-position NO - air return / spring assist	Y*
4-way	
Single solenoid, 2-position - air return	1
Double solenoid, 2-position	2
Single remote pilot, 2-position - air return	3*
Double remote pilot, 2-position	4*
Double solenoid, 3-position - APB	5
Double solenoid, 3-position - CE	6
Double solenoid, 3-position - PC	7
Double remote pilot, 3-position - APB	8*
Double remote pilot, 3-position - CE	9*
Double remote pilot, 3-position - PC	0*
Single solenoid, 2-position - air return / spring assist	E
Single remote pilot, 2-position - air return / spring assist	F*

Options	
Blank	None
02	Solenoid rotated 180° - pins down
MD††	Manual detent

†† Only available with operator function 1 & 3 and Enclosure "N", "X" or mobile voltages upon request.

Voltage [§]			
	AC		DC
	60Hz	50Hz	
42	24	22	
45			12
49			24
53	120	110	
57	240	230	
XX	Remote pilot - M5 or valve less solenoid		
YY	Remote pilot - 5/32" (4mm) tube		

Enclosure / lead length	
0	None, remote pilot valve
5	15mm 3-pin DIN 43650C (male only)
A	30mm square 3-pin - ISO 4400 form A (male only)
B	22mm rectangular 3-pin - type B industrial (male only)
C	3-pin automotive - mini
D	5-pin automotive - mini
E*	Intrinsically safe - 30mm 3-pin
F**	Hazardous duty 1/2" NPT conduit - 18" leads
G	Grommet - 18" leads
H	1/2" NPT conduit - 18" leads
N	Valve less "A - R" coil
Q†	Grommet - 72" leads
R	1/2" NPT conduit - 72" leads
X	Valve less 15mm solenoid

* 24 VDC & override "A" only.
 ** 12 VDC, 24 VDC, 120 VAC or 240 VAC.
 † 24 VDC only.

Port Size / Thread Type	
3-way	
1/4" NPT inline	1*
3/8" NPT inline	2*
1/4" BSPP "G" inline	6*
3/8" BSPP "G" inline	7*
4-way	
1/4" NPT inline	1*
3/8" NPT inline	2*
1/4" BSPP "G" inline	6*
3/8" BSPP "G" inline	7*
3/8" NPT subbase	J†
1/4" NPT NAMUR mount	T††
Subbase valve less base	V‡
1/4" BSPP "G" NAMUR mount	W††

Pilot Source / Pilot Exhaust	
Enclosures "0, 5 & X"	
None, remote pilot valve	0
Internal - port #1 / vented	B†
Dual pressure - port #3 / vented	E*
External - body / tapped M5	K†
External - manifold / vented	X†
Enclosures "A, B, C, D, E, F, G, H, N, Q & R"	
Internal - port #1 / tapped M5	A†
Internal - port #1 / vented	B†
Dual pressure - port #3 / tapped M5	D*†
External - body / tapped 1/8"	K†

* Not available for 3-way valves.
 † Not available for remote pilot valves.
 ‡ See pilot source note below.

Overrides [§]	
None. Remote pilot valve	0
No override	A†
Flush - non-locking	B*
Flush - locking	C
Extended - non-locking	D
Extended - locking	E*
Valve less 15mm solenoid	X

* Only available with encl. "5".
 † Only available with encl. "E".

* Available for use on IEM manifolds.
 † 4-way only includes base.
 ‡ Available with pilot source "0", "A", and "B" only.

Pilot Source 'X'
 External-Manifold / Vented or Tapped M5

INLINE & SUBBASE Valves -
 Only used IF an IEM Aluminum Bar Manifold requires a common external pilot signal through the manifold for low pressure / vacuum applications.

§ Enclosure '5' - Override / Voltage Availability
 S - Standard
 O - Option

Voltage code	Override code Standard				Voltage code	Override code "02" Option			
	B	C	D	E		B	C	D	E
42	O	O	-	-	42	O	O	-	-
45	O	O	-	-	45	O	O	-	-
49	S	S	O	O	49	S	S	O	O
53	S	S	O	O	53	S	S	O	O
57	O	O	-	-	57	O	O	-	-

Most popular.



For inventory, lead times, and kit lookup, visit www.pdnplu.com

B6 Series

B6 1 2 B B 5 49 - A

Basic series	
B6 series	B6

Engineering level	
A	Current
AL	CSA Current

Operator function	
3-way	
Single solenoid, 2-position NC - air return / spring assist	V
Single solenoid, 2-position NO - air return / spring assist	W
Single remote pilot, 2-position NC - air return / spring assist	X
Single remote pilot, 2-position NO - air return / spring assist	Y
4-way	
Single solenoid, 2-position - air return	1
Double solenoid, 2-position	2
Single remote pilot, 2-position - air return	3
Double remote pilot, 2-position	4
Double solenoid, 3-position - APB	5
Double solenoid, 3-position - CE	6
Double solenoid, 3-position - PC	7
Double remote pilot, 3-position - APB	8
Double remote pilot, 3-position - CE	9
Double remote pilot, 3-position - PC	0
Single solenoid, 2-position - air return / spring assist	E
Single remote pilot, 2-position - air return / spring assist	F

Options	
Blank	None
02	Solenoid rotated 180° - pins down

Voltage §			
	AC		DC
	60Hz	50Hz	
42	24	22	
45			12
49			24
53	120	110	
57	240	230	
XX	Remote pilot - M5 or valve less 15mm solenoid		
YY	Remote pilot - 5/32" (4mm) tube		

Port size / thread type	
3-way / 4-way	
3/8" NPT inline	2*
3/8" BSPP "G" inline	7*
3/8" NPT NAMUR mount	T†

* Available for use on IEM manifolds.
 † 4-way only. Available with pilot source "0", "A" and "B" only.

Pilot source / pilot exhaust	
Enclosures "0, 5 & X"	
None. Remote pilot valve	0
Internal - Port #1 / vented	B†
Dual pressure - port #5 / vented	H*
External - Body / tapped M5	K†
Enclosures "A, B, C, D, E, F, G, H, N, Q & R"	
Internal - Port #1 / tapped M5	A†
Internal - Port #1 / vented	B†
External - Body / tapped 1/8"	K†

* Not available for 3-way valves.
 † Not available for remote pilot valves.

Overrides§	
None, remote pilot valve	0
No override	A†
Flush - non-locking	B*
Flush - locking	C
Extended - non-locking	D
Extended - locking	E*
Valve less 15mm solenoid	X

* Only available with enclosure "5".
 † Only available with enclosure "E".

Enclosure / lead length	
0	None, remote pilot valve
5	15mm 3-pin DIN 43650C (male only)
A	30mm square 3-pin - ISO 4400 form A (male only)
B	22mm rectangular 3-pin - Type B industrial (male only)
E*	Intrinsically safe - 30mm 3-pin
F**	Hazardous duty 1/2" NPT conduit - 18" leads
G	Grommet - 18" leads
H	1/2" NPT conduit - 18" leads
N	Valve less "A - R" coil
Q	Grommet - 72" leads
R	1/2" NPT conduit - 72" leads
X	Valve less 15mm solenoid

* 24 VDC & override "A" only.
 ** 12 VDC, 24 VDC, 120 VAC or 240 VAC.
 † 24 VDC only.

§ Enclosure '5' - Override / Voltage Availability
 S - Standard
 O - Option

Voltage code	Override code				Voltage code	Override code			
	B	C	D	E		B	C	D	E
42	O	O	-	-	42	O	O	-	-
45	O	O	-	-	45	O	O	-	-
49	S	S	O	O	49	S	S	O	O
53	S	S	O	O	53	S	S	O	O
57	O	O	-	-	57	O	O	-	-

INLINE Valves -
 Only used IF an IEM Aluminum Bar Manifold requires a common external pilot signal through the manifold for low pressure / vacuum applications.

Most popular.



For inventory, lead time, and kit lookup, visit www.pdnplu.com

C

Inline Valves

Viking Lite

Viking Extreme

"B" Series

Air Saver Unit

ADEX Series

"N" Series

B7 & B8 Series

B7 1 3 A B G 53 - A

Basic series	
B7 series	B7
B8 series	B8

Engineering level	
A	Current
AL	CSA Current

Options	
Blank	None

Operator function	
3-way	
Single solenoid, 2-position NC - air return / spring assist	V
Single solenoid, 2-position NO - air return / spring assist	W
Single remote pilot, 2-position NC - air return / spring assist	X
Single remote pilot, 2-position NO - air return / spring assist	Y
4-way	
Single solenoid, 2-position - air return	1
Double solenoid, 2-position	2
Single remote pilot, 2-position - air return	3
Double remote pilot, 2-position	4
Double solenoid, 3-position - APB	5
Double solenoid, 3-position - CE	6
Double solenoid, 3-position - PC	7
Double remote pilot, 3-position - APB	8
Double remote pilot, 3-position - CE	9
Double remote pilot, 3-position - PC	0
Single solenoid, 2-position - air return / spring assist	E
Single remote pilot, 2-position - air return / spring assist	F

	AC		DC
	60Hz	50Hz	
42	24	22	
45			12
49			24
53	120	110	
57	240	230	
XX	Remote pilot - M5 or valve less solenoid		
YY	Remote pilot - 5/32" (4mm) tube		

Enclosure / lead length	
0	None, remote pilot valve
5	15mm 3-pin DIN 43650C (male only)
A	30mm square 3-pin - ISO 4400 form A (male only)
B	22mm rectangular 3-pin - Type B industrial (male only)
E*	Intrinsically safe - 30mm 3-pin
F**	Hazardous duty 1/2" NPT conduit - 18" leads
G	Grommet - 18" leads
H	1/2" NPT conduit - 18" leads
N	Valve less "A - R" coil
R	1/2" NPT conduit - 72" leads
X	Valve less 15mm solenoid

Port size / thread type	
B7 series	
1/2" NPT inline	3*
1/2" BSPP "G" inline	8*
B8 series	
3/4" NPT inline	4*
3/4" BSPP "G" inline	9*

* Available for use on IEM manifolds.

Pilot source / pilot exhaust	
Enclosures "0, 5 & X"	
None. Remote pilot valve	0
Internal - Port #1 / vented	B†
External - Body / tapped M5	K†
Enclosures "A, B, C, D, E, F, G, H, N, Q & R"	
Internal - Port #1 / tapped M5	A†
Internal - Port #1 / vented	B†
External - Body / tapped 1/8"	K†

† Not available for remote pilot valves.

Overrides§	
None, remote pilot valve	0
No override	A†
Flush - non-locking	B*
Flush - locking	C
Extended - non-locking	D
Extended - locking	E*
Valve less 15mm solenoid	X

* Only available with encl. "5".

† Only available with encl. "E".

* 24 VDC & Override "A" only.

** 12 VDC, 24 VDC, 120 VAC or 240 VAC.

§ Enclosure "5" - Override / Voltage Availability

S - Standard

O - Option

Voltage code	Override code			
	B	C	D	E
42	O	O	-	-
45	O	O	-	-
49	S	S	O	O
53	S	S	O	O
57	O	O	-	-

C
Inline Valves
 Viking
 Lite
 Viking
 Extreme
 "B"
 Series
 Air Saver
 Unit
 ADEX
 Series
 "N"
 Series

INLINE Valves -
 Only used IF an IEM Aluminum Bar Manifold requires a common external pilot signal through the manifold for low pressure / vacuum applications.

Most popular.



For inventory, lead times, and kit lookup, visit www.pdnplu.com

IEM Bar Manifold, Inline Valves Only



Valve series	Valve function	## – Stations	Manifold only (NPT)	Manifold only (BSPP)
B3	3-way	02 to 12	PSG3BXN##NP	PSG3BXG##NP
B3	4-way	02 to 12	PSM3BXN##NP	PSM3BXG##NP
B5	3-way	02 to 12	PSG5BXN##NP	PSG5BXG##NP
B5	4-way	02 to 12	PSM5BXN##NP	PSM5BXG##NP
B6	3-way	02 to 12	PSG6BXN##NP	PSG6BXG##NP
B6	4-way	02 to 12	PSM6BXN##NP	PSM6BXG##NP
B7, B8	4-way	02 to 12	PSM7BXN##NP	PSM7BXG##NP

Kits include: (1) manifold, valve hold down bolts, gaskets. For external pilot valve option "X", external manifold galley must be pressurized.

IEM Bar Manifold Add-A-Fold Assembly

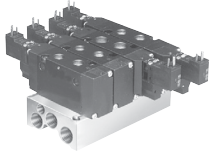

Valve series	Valve function	## – Stations	Manifold assembly (NPT)	Manifold assembly (BSPP)
B3	3-way, 1/4	02 to 12	AAPSG3BXN##NP	AAPSG3BXG##NP
B3	4-way, 1/4	02 to 12	AAPSM3BXN##NP	AAPSM3BXG##NP
B5	3-way, 3/8	02 to 12	AAPSG5BXN##NP	AAPSG5BXG##NP
B5	4-way, 3/8	02 to 12	AAPSM5BXN##NP	AAPSM5BXG##NP
B6	3-way, 1/2	02 to 12	AAPSG6BXN##NP	AAPSG6BXG##NP
B6	4-way, 1/2	02 to 12	AAPSM6BXN##NP	AAPSM6BXG##NP
B7, B8	4-way, 1/2	02 to 12	AAPSM7BXN##NP	AAPSM7BXG##NP

Kits include: (1) manifold, valve hold down bolts, gaskets and assembly. For external pilot valve option "X", external manifold galley must be pressurized.

How to Order:

1. List Add-A-Fold Assembly Part Number as line item 1
2. List the desired valves series part number in subsequent line items after the Add-A-Fold Assembly part number to complete the ordering code. Include all valves and blanking kits required. The left most station is station # 1 looking at the #12 end of the manifold.

Example: B3, 4-way manifold with station #1 blanked off with valves assembled

Line	Qty	Part number	Comment
1	1	AAPSM3BXN03NP	Add-A-Fold Assembly
2	1	PS2920P	Blank Plate - station 1
3	1	B3100BB549C	4-way B3 - station 2
4	1	B330000XXC	4-way B3 - station 3

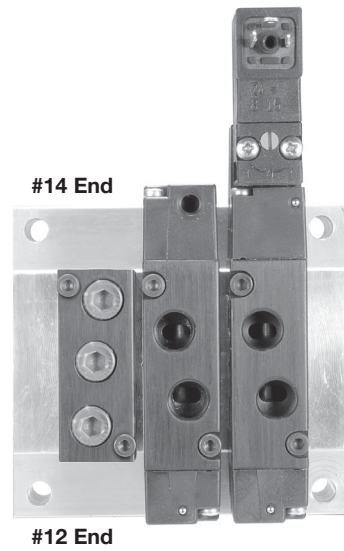

#12 End

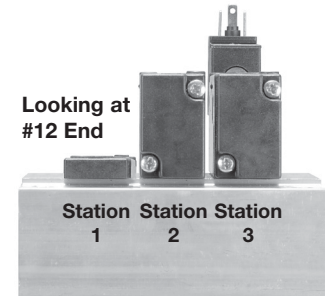

Looking at #12 End

Station Station Station
1 2 3

Most popular.



For inventory, lead time, and kit lookup, visit www.pdnplu.com

B3 Subbase Side Ported Manifold, Subbase Valves Only



Valve series	Valve function	## – Stations	Manifold only (NPT)	Manifold only (BSPP)
B3	4-way	02 to 12	PSJ3B1N##NP	PSJ3B1G##NP

Kits include: (1) manifold, valve hold down bolts, gaskets. For external pilot valve option "X", external manifold galley must be pressurized. Replace ## with number of valve stations.

35mm DIN Rail Mount

B3 Subbase Side Ported Manifold Add-A-Fold Assembly

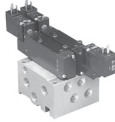

Valve series	Valve function	## – Stations	Manifold assembly (NPT)	Manifold assembly (BSPP)
B3	4-way	02 to 12	AAPSJ3B1N##NP	AAPSJ3B1G##NP

Kits include: (1) manifold, valve hold down bolts, gaskets and assembly. For external pilot valve option "X", external manifold galley must be pressurized.

- Utilizes Subbase mount B3 valves.
- Available for 4-Way valves. If 3-way function is required, plug a cylinder port.
- Common External Pilot galley is standard.
- Standard Internal Pilot valves need not use this galley, and the galley does not need to be plugged.
- External Pilot Valves – "X", must have Common External Galley pressurized.

IEM Stackable Manifolds

- Individual Manifold Bases stack together to form lightweight custom length manifold system.
- Easy-to-connect male / female tie rods for modular assembly.
- Utilizes B3 and B5 4-way Inline Valves.
- Low-cost built-in Flow Controls with heavy-duty brass adjusting needles to control meter-out exhaust flow.
- Accessories include Isolator Plugs for pressure isolation and Universal Blanking Plates for auxiliary inlet and exhaust supply and future valve additions.

Series	Type	Kit number	
		Standard	Flow control
B3	4-way	PS2917P	PS2918P
B5	4-way	PS2817P	PS2818P

Kit includes: (1) manifold base, (2) hold-down bolts, tie-rods, gaskets and o-rings.

Isolator Plugs

Series	Description	Kit number
B3	4-way, IEM stackable	PS2919P
B5	4-way, IEM stackable	PS2819P

Used to isolate the #1, #3 or #5 gallery between two manifold bases. (IEM stackable only)

Kit includes: (3) plugs and (6) o-rings

End Plate Kits

Series	Type	Port Type	Kit number
B3	4-way, NPT	1/8	PS2915P
B5	4-way, NPT	1/4	PS2815P*

Kit includes: right and left end plate, o-rings, socket head cap screws, flat washers and lockwashers.

* B5 4-Way use the same kit

Most popular.

Single Subbase (subbase valves only)

Series	Type	Kit number
B3	4-way, 1/4" NPT	PS2934P
B5	4-way, 3/8" NPT	PS2834P

Kit includes: (1) subbase. (Hold down bolts & gasket are included with valve.)

Blanking Plate

Series	Type	IEM universal		IEM	Subbase
		NPT	BSPP "G"	Blank	Blank
B3	3-way	PS2966P	PS2967P	PS2968P	—
	4-way	PS2920P	PS2921P	PS2969P	PS2994P
B5	3-way	PS2866P	PS2867P	PS2868P	—
	4-way	PS2820P	—	PS2869P	—
B6	3-way 4-way	PS2620P	—	—	—
B7-B8	4-way	PS2520P	—	PS2569P	—

Kit includes: (1) plate, (2) screws, seal / gaskets

DIN Rail Hardware Kit

Valve type	IEM bar	Part number
B3	(2) Screws, (2) Nuts, (2) Clamps	PS2991P

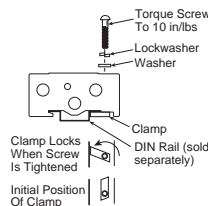

Solenoid Kits – B3 ‘C’, B5 ‘C’, B6 ‘A’, B7 ‘A’, B8 ‘A’ 3-Pin, EN175301-803 (Former DIN 43650C), 15mm

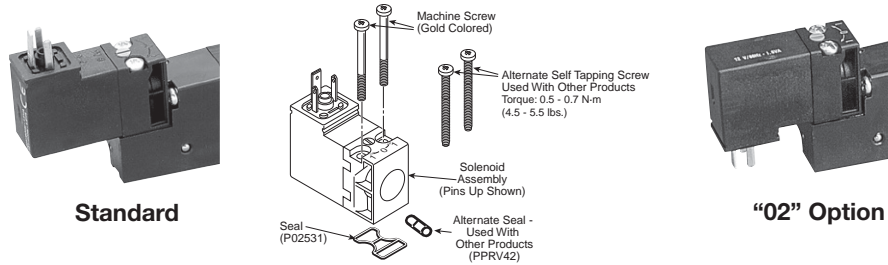

PS2982*##P – Enclosure ‘5’

Override *	## Voltage						
	42	45	47†	48†	49	53	57
B	O	O	-	-	S	S	O
C	O	O	-	-	S	S	O
D	-	-	O	O	O	O	-
E	-	-	O	O	O	O	-

S - Standard; O - Option

† Mobile voltage

Kit includes: Solenoid, (2) machine screws, (2) self threading screws, (1) gasket, (1) 3-cell gasket.

PS3541*##P – Enclosure ‘5 with “02” Option

Override *	## Voltage				
	42	45	49	53	57
B	O	O	S	S	O
C	O	O	S	S	O
D	-	-	O	O	-
E	-	-	O	O	-

Solenoid Kits Alternate Enclosures

P2FC A 4 49

Enclosures / lead length	
30mm square 3-pin – ISO 4400 form A (male only)	A
22mm rectangular 3-pin – type B industrial (male only)	B
Hazardous duty, FM / CSA	F*
Grommet - 18" leads	G
1/2" NPT conduit - 18" leads	H
Grommet 72" leads	Q
1/2" Conduit 72" leads	R

Voltage / frequency	
42	24VAC
45	12VDC
47*	12 VDC mobile
48*	24 VDC mobile
49	24VDC
53	120VAC
57	240VAC

* Only available with enclosures "A", "B" & "G".

* Only available with voltage codes "45", "49", "53" & "57".



Option A & E
 30mm Square
 3-pin ISO 4400, DIN 43650A



Option B
 22mm Rectangular
 3-pin DIN, Type B Industrial



Option G & Q
 Grommet, 18" or 72" Leads



Option F, H & R
 1/2" Conduit, 18" or 72" Leads

Most popular.

Intrinsically Safe Solenoid Valves (“E” Option)

Hazardous Location Class:
 Class I; Groups A, B, C & D
 Class II; Groups E, F, & G
 Class III; Div. I

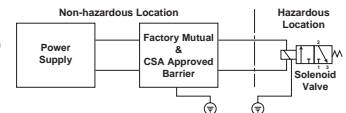

For use in low voltage (24VDC) Intrinsically Safe applications. **NO OTHER VOLTAGE IS APPROVED. 1.6W coil.**

36mm coil width.

Comes standard with non-lighted solenoid connector.

Must be connected to an FM approved Barrier.

For dimensions, reference standard solenoid models.

Maximum internally piloted valve pressure is 115 PSIG.

Pressures to 145 PSIG can be used when external pilot is utilized and pilot pressure is limited to 115 PSIG.

Intrinsically Safe Solenoid Pilot Assembly Kits

Description	Part number
24VDC	P2FS13N1AE49

Kit includes: coil, armature, connector, o-ring and screws.

Hazardous Duty Solenoid Valves (“F” Option)

Hazardous Location Class:
 Class I; Zone I EX, M, II & T4
 Class I; Div. I. Groups A, B, C, & D
 Class II & III; Div. I. Groups E, F, & G

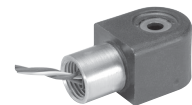

Comes standard with 1/2" conduit connection.

Voltage range = ± 10%, 4.6W

Ambient temperature range = -20°C (-4°F) to 60°C (140°F)

Duty factor = 100%

IP65 rated (with connected conduit connector)

Notes:

1. Maximum non-hazardous location voltage not to exceed 250V RMS.
2. Factory Mutual requires connections per ISA RP 12.6 instructions.
3. CSA requires "Installation to be in accordance with the Canadian Electrical Code. Part I."
4. The hazardous duty coils are wider in size than both the B5 and the B6 valve. If mounted on a manifold, the valves need to be staggered to fit.



For inventory, lead time, and kit lookup, visit www.pdnplu.com

15mm 3-Pin DIN 43650C, 8mm Pin Spacing

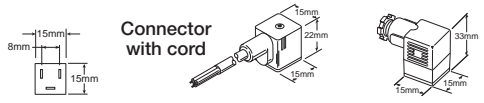

	Cord length	Connector	Connector with cord
Unlighted	18 Inches	PS2932BP	PS2932HBP
Unlighted	6 Feet	PS2932BP	PS2932JBP
Light – 12VAC or DC	6 Feet	PS294675BP	PS2946J75BP*
Light – 24VAC or DC	6 Feet	PS294679BP	PS2946J79BP*
Light – 110/120VAC	6 Feet	PS294683BP	PS2946J83BP*
Light – 240/230VAC		PS294687BP	N/A

* LED with surge suppression.
Note: Max ø6.5mm cable size required for connector w/o 6' (2m) cord.
 IP65 rated when properly installed.

Engineering data:
 Conductors: 2 poles plus ground, polarity insensitive
 Cable range (connector only): 4 to 6mm (0.16 To 0.24 Inch)
 Contact spacing: 8mm

15mm 3-Pin DIN 43650C to 1/2" Conduit

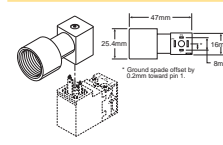

Description	Connector
1/2" NPTF conduit – Unlighted with 3' (1m) leads 20 AWG wire	PS2998P

Note: Rated up to 250VAC or VDC; 6 amps
 IP65 rated when properly installed.

30mm Square 3-Pin – ISO 4400, DIN 43650A (Use with Enclosure "A")

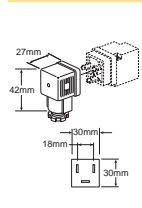

Description	Connector with 6' (2m) cord	Connector
Unlighted	PS2028JCP	PS2028BP
Light – 6-48V, 50/60Hz, 6-48VDC	PS2032J79CP*	PS203279BP
Light – 120V/60Hz	PS2032J83CP*	PS203283BP
Light – 240V/60Hz	N/A	PS203283BP

* LED with surge suppression.
Note: Max ø6.5mm cable size required for connector w/o 6' (2m) cord. IP65 rated when properly installed.
Engineering data:
 Conductors: 2 poles plus ground; cable range (connector only): 8 to 10mm (0.31 To 0.39 Inch); contact spacing: 18mm

22mm Rectangular 3-Pin – Type B Industrial (Use with Enclosure "B")

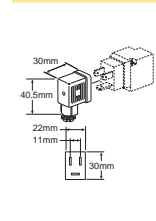

Description	Connector with 6' (2m) cord	Connector
Unlighted	PS2429JBP	PS2429BP
Light – 24V60Hz, 24VDC	PS2430J79BP*	PS243079BP
Light – 120V/60Hz	PS2430J83BP*	PS243083BP
Light – 240V/60Hz	N/A	PS243087BP

* LED with surge suppression.
Note: Max ø6.5mm cable size required for connector w/o 6' (2m) cord. IP65 rated when properly installed.
Engineering Data:
 Conductors: 2 Poles Plus Ground; Cable Range (Connector Only): 6 to 8mm (0.24 to 0.31 Inch); Contact Spacing: 11mm

3-Pin / 5-Pin Male Automotive Connectors (Use on 22mm Rectangular 3-Pin Solenoid)

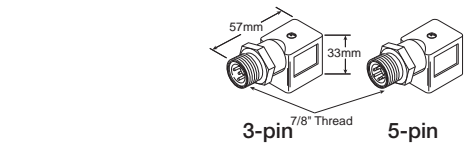

Description	3-pin	5-pin
Unlighted	PS2893CP	PS2893DP
Lighted - Voltage	PS2893C##P	PS2893D##P

— 79 = 6 to 48VAC/VDC
 83 = 100 to 240VAC/48 to 120 VDC

C
 Inline Valves
 Viking Lite
 Viking Extreme
 Series "B"
 Air Saver Unit
 ADEX Series
 "N" Series

Most popular.



For inventory, lead times, and kit lookup, visit www.pdnplu.com

Solenoid Information (Solenoids are rated for continuous duty.)

Voltage						Voltage							
AC			Enclosure "5"			AC			Enclosure "A"				
Code	60Hz	50Hz	DC	Power Consumption	Holding (Amps)	Code	60Hz	50Hz	DC	Power Consumption	Holding (Amps)	Power Consumption	Holding (Amps)
42	24	22		1.6VA	.065	42	24	22		3.9VA	.136	7.3VA	.309
45			12	1.2W	.098	45			12	2.6W	.208	4.6W	.365
47*			12	0.91W	.074	47*			12	—	—	4.9W	.298
48*			24	0.91W	.033	48*			24	—	—	4.8W	.142
49			24	1.2W	.049	49			24	2.7W	.112	4.8W	.200
53	120	110		1.6W	.013	53	120	110		4.1VA	.033	6.3VA	.047
57	240	230		1.6W	.007	57	240	230		3.7VA	.017	6.4VA	.026

Note: For enclosure "5" with "02" Option, solenoid wattage is 1.8W (2.4VA). Response time is 10% faster. Voltage rated +10 / -15%.

* 47 and 48 code are mobile voltages. voltage +25 / -30%.

Response Time (Sec)

Valve Size	Port Size	Enclosure "5"				Enclosure "A, B, C, D, G, H, Q & R"			
		0 Cu. In. Test Chamber		25* Cu. In. Test Chamber		0 Cu. In. Test Chamber		25* Cu. In. Test Chamber	
		Fill	Exhaust	Fill	Exhaust	Fill	Exhaust	Fill	Exhaust
2-Position Single Solenoid / Internal Air Return									
B3	1/8"	.024	.026	.149	.242	—	—	—	—
B5	1/4"	.038	.040	.106	.156	.025	.026	.090	.142
B5*	3/8"	.039	.041	.150	.245	.025	.027	.141	.241
B6*	3/8"	.037	.038	.096	.132	.016	.018	.084	.119
B7	1/2"	.073	.075	.195	.275	.049	.051	.167	.249
B8	3/4"	.072	.074	.166	.226	.049	.051	.142	.206
2-Position Single Solenoid Spring / Air Return									
B3	1/8"	.019	.022	.128	.217	—	—	—	—
B5	1/4"	.039	.041	.108	.162	.024	.026	.091	.143
B5*	3/8"	.040	.042	.169	.261	.024	.026	.143	.240
B6*	3/8"	.035	.036	.096	.133	.023	.024	.083	.120
B7	1/2"	.071	.074	.194	.275	.049	.051	.167	.249
B8	3/4"	.072	.074	.176	.239	.046	.048	.142	.204
2-Position Double Solenoid									
B3	1/8"	.013	.015	.122	.213	—	—	—	—
B5	1/4"	.016	.018	.082	.132	.012	.014	.077	.128
B5*	3/8"	.016	.018	.129	.222	.016	.018	.128	.225
B6*	3/8"	.016	.017	.074	.110	.012	.013	.071	.107
B7	1/2"	.026	.028	.145	.228	.022	.024	.138	.225
B8	3/4"	.026	.028	.123	.185	.022	.024	.115	.178
3-Position Double Solenoid									
B3	1/8"	.021	.023	.091	.141	—	—	—	—
B5	1/4"	.022	.023	.091	.141	.011	.011	.079	.135
B5*	3/8"	.022	.024	.135	.229	.016	.019	.135	.234
B6*	3/8"	.024	.026	.094	.139	.016	.018	.084	.132
B7	1/2"	.049	.051	.167	.257	.028	.030	.148	.238
B8	3/4"	.035	.037	.136	.206	.028	.030	.130	.195

Average Fill Time (Seconds): With 100 PSIG supply, time required to fill from 0-90 PSIG and exhaust from 100 PSIG to 10 PSIG is measured from instant of energizing, or de-energizing 120V/60Hz solenoid. Times shown are average.

* For 3/8" ported, 50 cu. in. test chamber is used. For 1/2" & 3/4", a 200 cu. in. test chamber is used.

C

Inline Valves

Viking Lite

Viking Extreme

"B" Series

Air Saver Unit

ADEX Series

"N" Series



For inventory, lead time, and kit lookup, visit www.pdnplu.com

Sandwich Regulators

- Use with B3 subbase valves on 5-ported subbase bar manifolds.
- Common port or dual port regulation control.
- Unregulated pressure supplied to valve pilot - use pilot source - 'X'.
- Easy adjust knob control.

Pressure range	Cv	Common port with gauge *	Dual port without gauge
5-125 PSI	.33	PS2930166P	PS2930233P

* Gauge is 160 PSI. Gauge shipped unassembled. For different gauge mounting configuration, use brass adapters listed at bottom of page.

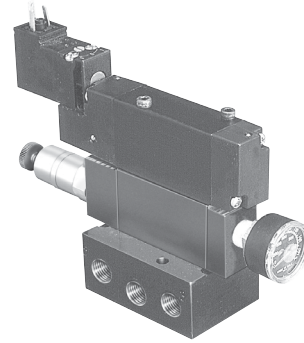

Brass Adapters for Gauge –

- | | |
|--|---|
| 1/8" to 1/8" Female Coupling 207P-2 | 1/8" to 1/8" 45° Female Elbow 2201P-2-2 |
| 1/8" Male to Female Adapter 222P-2-2 | 1/8" to 1/8" 90° Female Elbow 2200P-2-2 |

Gauge 1" Face –

- 0-160 PSI PS4051160BP

Alternate Solenoid Enclosures

- Enclosure "A": 2.6W - 4.1VA (Coil rotates in 45° increments)
- Enclosure "B" - "R": 4.6W - 7.3VA (Coil rotates in 90° increments)

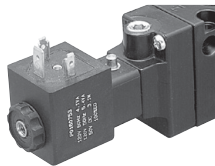

"A" 30mm 3-Pin



"C" 3-Pin Mini

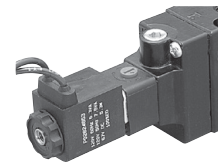

"G". "Q" Grommet

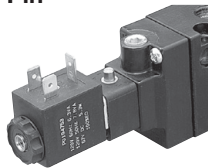

"B" 22mm 3-Pin



"D" 5-Pin Mini

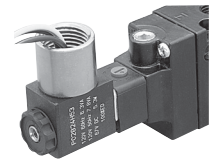

"F". "H". "R" 1/2" Conduit

Tube Fitting Remote Pilot

- "YY" Option
- 5/32" (4mm) Tube Fitting

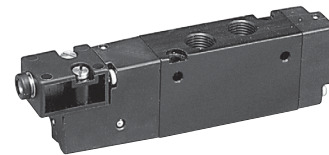

B5 With Manual Detent

- Positive mechanical contact of the override knob assures actuation of valve, however, knob does not move during normal cycling.
- Hard coated override to resist harsh environments.
- Override return spring is stainless steel, for harsh environments.
- Heavy duty locking mechanism to maintain position.
- Use in combination with mobile voltages or valve less solenoid.

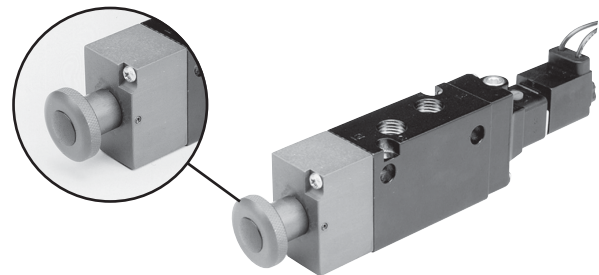

Most popular.

C
Inline Valves
 Viking
 Lite
 Viking
 Extreme
 Series
 "B"
 Air Saver
 Unit
 ADEX
 Series
 "N"
 Series



For inventory, lead times, and kit lookup, visit www.pdnplu.com

Pilot Configuration

B - Internal - Port #1 / Vented (B3 Shown)

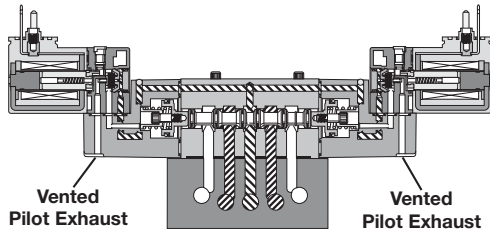

E - Dual Pressure - Port #3 / Vented (B3 Shown)

H - Dual Pressure - Port #5 / Vented (Similar)

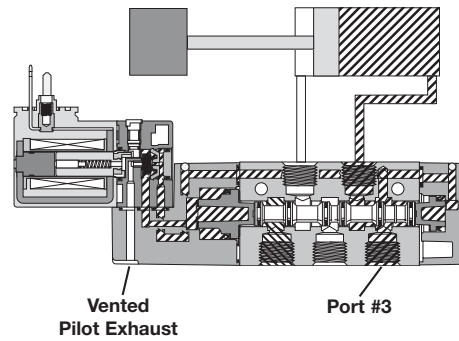

D - Dual Pressure - Port #3 / Tapped M5 (B5 Shown)

G - Dual Pressure - Port #5 / Tapped M5 (Similar)

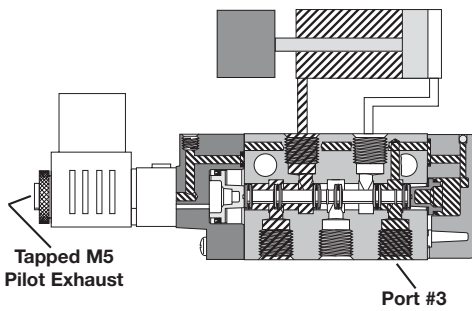

K - External - Body / Tapped M5 (B3 Shown)

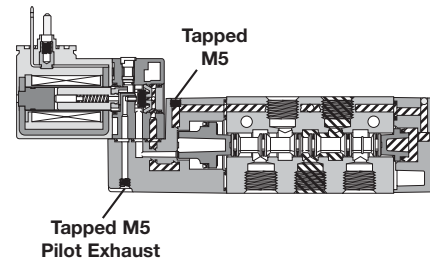

Common Port

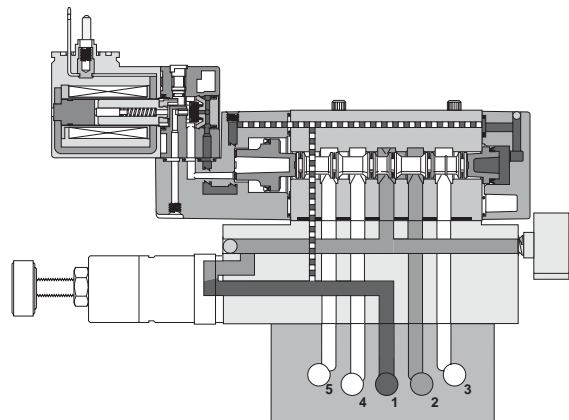

Dual Port

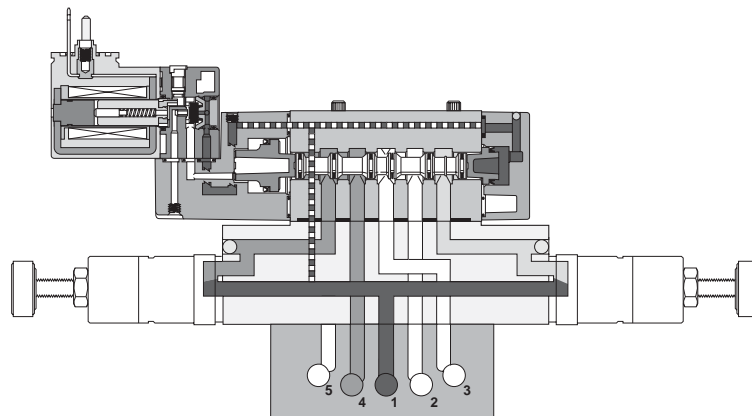

C

Inline Valves

Viking Lite

Viking Extreme

"B" Series

Air Saver Unit

ADEX Series

"N" Series



For inventory, lead time, and kit lookup, visit www.pdnplu.com

C55

Parker Hannifin Corporation
 Pneumatic Division
 Richland, Michigan
www.parker.com/pneumatics

B3C Series

Spool / Body Service Kits

Kit Includes:

PS2901CP	4-Way, 2-Pos	Item 15, 21 (2), 24, 25, 31 (2), grease packet
PS2902CP	4-Way, 3-Pos APB	Item 16, 21 (2), 31 (2), grease packet
PS2903CP	4-Way, 3-Pos CE	Item 16, 21 (2), 31 (2), grease packet
PS2904CP	4-Way, 3-Pos PC	Item 16, 21 (2), 31 (2), grease packet
PS2971CP	3-Way, 2-Pos	Item 15, 21 (2), 24, 25, 31 (2), grease packet

Valve to Manifold Kits

PS2980P	Gasket (10) - Inline 3-Way Valve to Segmented Manifold
PS2981P	Gasket (10) - Inline 4-Way Valve to Segmented Manifold
PS2984P	O-ring (10) - Inline Valve to IEM Bar Manifold
PS2986P	Gasket - Subbase Valve to Subbase Bar Manifold; Item 4 (10), 39 (10)
PS2987P	Mounting Bolts (10) - Inline Valve / Subbase Valve

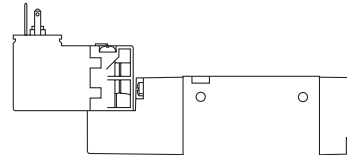

Manifold to Manifold Kit

PS2996P	Gasket (10), Tie Rods (10) - 4-Way Manifold
---------	---

Sandwich Regulator Cartridge Kit

PS299922P	2-60 PSI Cartridge (Item A, B)
PS299933P	5-125 PSI Cartridge (Item A, B)

Solenoid Kit Kit Includes: 35, 36, 34

PS2982*##P	3-Pin, EN175301-803, 15mm
PS3541*##P	3-Pin, EN175301-803, 15mm Option 2

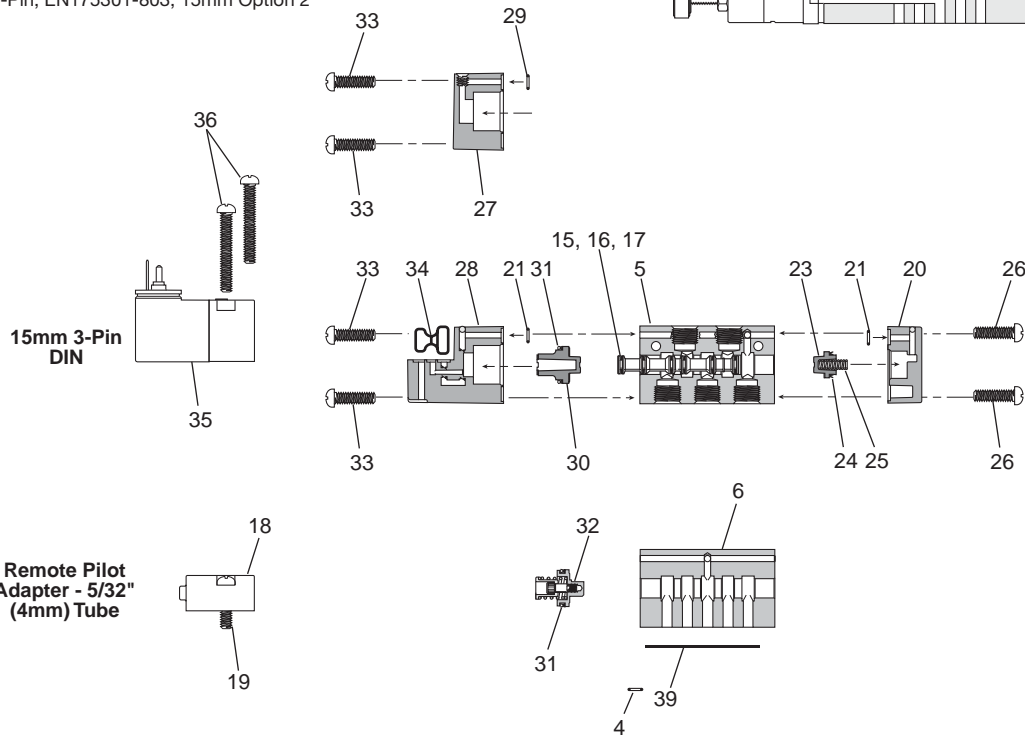
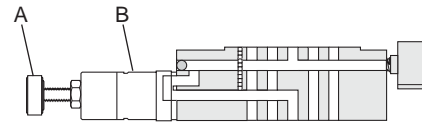

15mm 3-Pin DIN

Remote Pilot Adapter - 5/32" (4mm) Tube

Item List – Parts not sold separately.

Item Description	Item Description	Item Description
4* O-ring - Ext Pilot Valve to Manifold	23 Return Piston	31* Lip Seal - Operator Piston
5 Inline Body - Tapped Ports	24* Lip Seal - Return Piston	32 Operator Piston Mechanism - 3-Position
6 Subbase Body	25* Spring, Return Assist	33 Screws - Operator Adapter
7 Inline Body - Tube Ports	26 Screws - Return Operator	34* Gasket - Solenoid to Adapter
15* Spool - 2-Position (Seals Assembled)	27 Remote Pilot Operator	35* 15mm Solenoid
16* Spool - 3-Position (Seals Assembled)	28a Solenoid Adapter - Vent Exhaust	36* Self Tapping Screw - Solenoid (Effective May 99)
17* Spool Seal	28b Solenoid Adapter - Ext Pilot. Vent Exhaust	36* Machine Screw - Solenoid (Jan 96 - May 99)
18 Remote Pilot Adapter (PVAP111)	28c Solenoid Adapter - Ext Pilot. Tapped Exhaust	39* Gasket - Subbase Valve to Base
19 Screw - Remote Pilot Adapter	28d Solenoid Adapter - Tapped Exhaust	40* Mounting Screws - Subbase Valve
20 Return Operator	29 O-ring - Remote Pilot	
21* Gasket - Body to Operator	30 Operator Piston - 2-Position	

Note: * Parts are available in kits shown. For kit components, order VALVE LESS SOLENOID for assembled and tested repair valve.



For inventory, lead times, and kit lookup, visit www.pdnplu.com

C
 Inline Valves
 Viking Lite
 Viking Extreme
 Series "B"
 Air Saver Unit
 ADEX Series
 "N" Series

B5C Series

Spool / Body Service Kits

- | | | | |
|----------|------------------|----------------------|---|
| PS2801*P | 4-Way, 2-Pos | <i>Kit Includes:</i> | Item 2, 10 (2), 14, 15, 116, 6 (2), grease packet |
| PS2802*P | 4-Way, 3-Pos APB | | Item 3, 6 (2), 10 (2), 13 (2), grease packet |
| PS2803*P | 4-Way, 3-Pos CE | | Item 3, 6 (2), 10 (2), 13 (2), grease packet |
| PS2804*P | 4-Way, 3-Pos PC | | Item 3, 6 (2), 10 (2), 13 (2), grease packet |
| PS2871*P | 3-Way, 2-Pos NC | | Item 2, 10 (2), 14, 15, 116, 6 (2), grease packet |
- * Fluorocarbon Seal Kit (i.e. PS2801VP)

Pilot Replacement Kit – Alternate Enclosure

- Kit Includes:* Item 6, 9, 10, 11, 17 (2), 18 (2), 13, 19, 20, 22, 23, 24 (2), 57, 58 Assembled
- | | |
|-----------|-------------------|
| PS2897GBP | Non-Locking, BSPP |
| PS2897GCP | Locking, BSPP |
| PS2897NBP | Non-Locking, NPT |
| PS2897NCP | Locking, NPT |

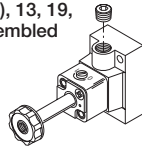

Armature / Override Kit

- Kit Includes:* Item 22, 23, 24 (2), 57, 58 Assembled

P2FP13N4D*
Non-Locking

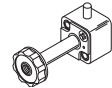

P2FP13N4C*
Locking

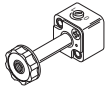

* Comes with a Thru Nut and A Diffuser Nut.

1/2" Conduit Connector

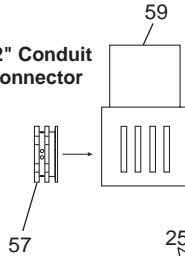

15mm 3-Pin DIN

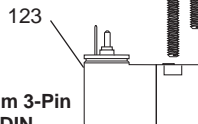

Remote Pilot Adapter - 5/32" (4mm) Tube

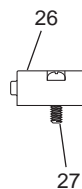

Valve to Manifold Kits

- | | |
|---------|--|
| PS2884P | O-ring (10) - Inline Valve to IEM Manifold (All) |
| PS2886P | Gasket (10) - Subbase Valve to Subbase |
| PS2887P | Mounting Bolts (10) - Inline & Subbase Valve |

Manifold to Manifold Kit

- | | |
|---------|---|
| PS2896P | Gasket (10), Tie Rods (10) - 4-Way Manifold |
|---------|---|

Solenoid Kit

- Kit Includes:* 25, 122, 123
- | | |
|------------|------------------------------------|
| PS2982*##P | 3-Pin, EN175301-803, 15mm |
| PS3541*##P | 3-Pin, EN175301-803, 15mm Option 2 |

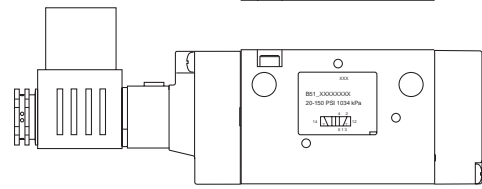
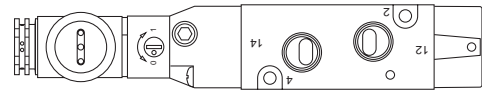

* Items 6A, 6B, 14 & 15, Used Only in 2-Position Kit.

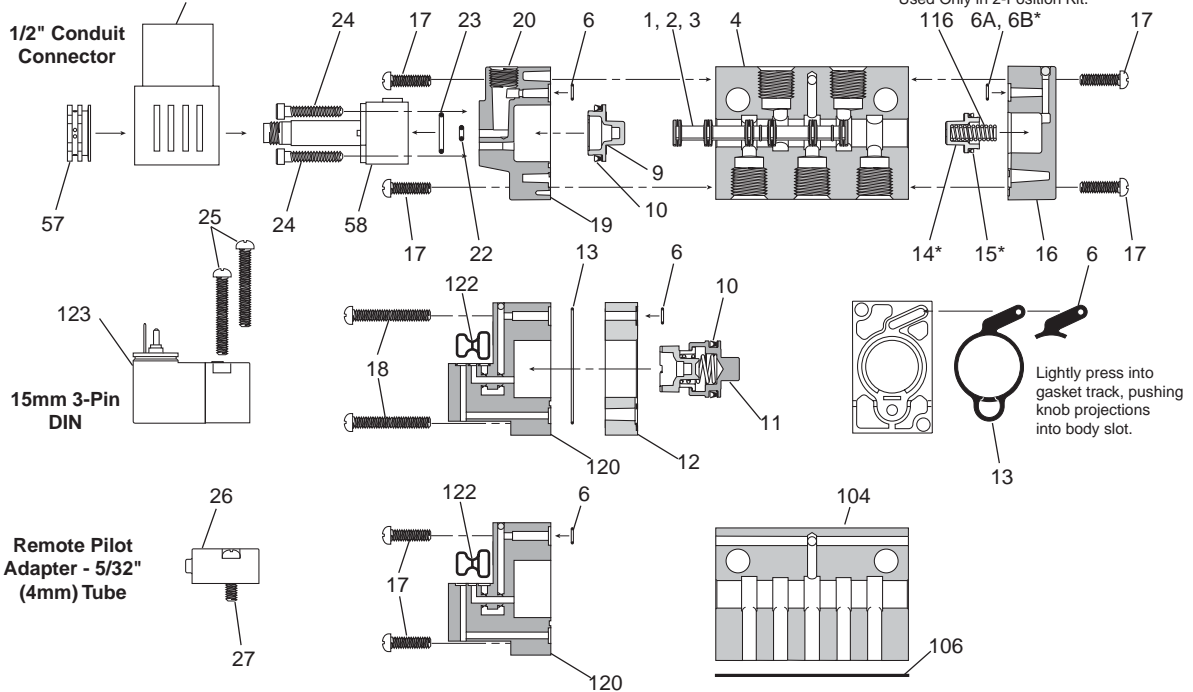

Item List – Parts not sold separately.

Item	Description	Item	Description	Item	Description
1*	Spool Seal	15*	Lip Seal - Return Piston	57*	Solenoid Nut
2*	Spool - 2-Position (Seals Assembled)	16	Return Operator	58a*	Solenoid Base Assembly - Locking
3*	Spool - 3-Position (Seals Assembled)	17*	Screws - Operator Adapter - 2-Position	58b*	Solenoid Base Assembly - Non Locking
4	Inline Body	18*	Screws - Operator Adapter - 3-Position	59*	Coil - Alternate Enclosure (see Page C51)
6A*	Gasket - Body to Operator	19*	Operator Adapter - Alt Enclosure	104	Subbase Body
6B	O-ring - Body to Operator (Effective July 2007)	20*	1/8" NPT Pipe Plug	106*	Gasket - Subbase Valve to Base
7	Remote Pilot Operator	22*	O-ring - Small - Solenoid Base	116*	Spring, Return Assist
9	Operator Piston - 2-Position	23*	O-ring - Large - Solenoid Base	120a	Solenoid Adapter - Vent Exhaust
10*	Lip Seal - Operator Piston	24*	Bolts - Solenoid Base	120b	Solenoid Adapter - Tapped Exhaust
11	Operator Piston Mechanism - 3-Position	25a*	Self Tapping Screw - Solenoid (Effective May 99)	120d	Solenoid Adapter - Ext Pilot. Vent Exhaust
12	Adapter - 3-Position	25b*	Machine Screw - Solenoid (Jan 96 - May 99)	120e	Solenoid Adapter - Ext Pilot. Tapped Exhaust
13*	Gasket - 3-Position Adapter to Body	26	Remote Pilot Adapter - 5/32" Tube (PVAP111)	122*	Gasket - Solenoid to Adapter
14	Return Piston	27	Screws - Remote Pilot Adapter	123*	15mm Solenoid

Note: * Parts are available in kits shown. For kit components, order VALVE LESS SOLENOID for assembled and tested repair valve.



For inventory, lead time, and kit lookup, visit www.pdnplu.com

B6A Series

Spool / Body Service Kits

PS2601P	4-Way, 2-Pos	Kit Includes:
PS2602P	4-Way, 3-Pos APB	Item 2, 6 (2), 9 (2), 11, 14, grease packet
PS2603P	4-Way, 3-Pos CE	Item 3, 6 (2), 9 (2), 13 (2), grease packet
PS2604P	4-Way, 3-Pos PC	Item 3, 6 (2), 9 (2), 13 (2), grease packet
PS267101P	3-Way, 2-Pos. NC	Item 2, 6, 9, 14, grease packet
PS267102P	3-Way, 2-Pos. NO	Item 2, 6, 9, 14, grease packet

Valve to Manifold Kits

PS2684P	O-ring (10) - Inline Valve to IEM Manifold
PS2887P	Mounting Bolts (10) - Inline Valve

Pilot Replacement Kit – Alternate Enclosure

Kit Includes: Item 6, 8, 9, 10, 16 (2), 17 (2), 18, 13, 20, 22, 23, 24 (2), 57, 58 Assembled

PS2897GBP	Non-Locking, BSPP
PS2897GCP	Locking, BSPP
PS2897NBP	Non-Locking, NPT
PS2897NCP	Locking, NPT

Armature / Override Kit –

Kit Includes: Item 22, 23, 24 (2), 57, 58 Assembled

P2FP13N4D* Non-Locking

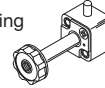

P2FP13N4C* Locking

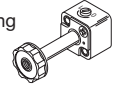

* Comes with a Thru Nut and A Diffuser Nut.

Solenoid Kit Kit Includes: 25, 122, 123

PS2982*##P 3-Pin, EN175301-803, 15mm

PS3541*##P 3-Pin, EN175301-803, 15mm Option 2

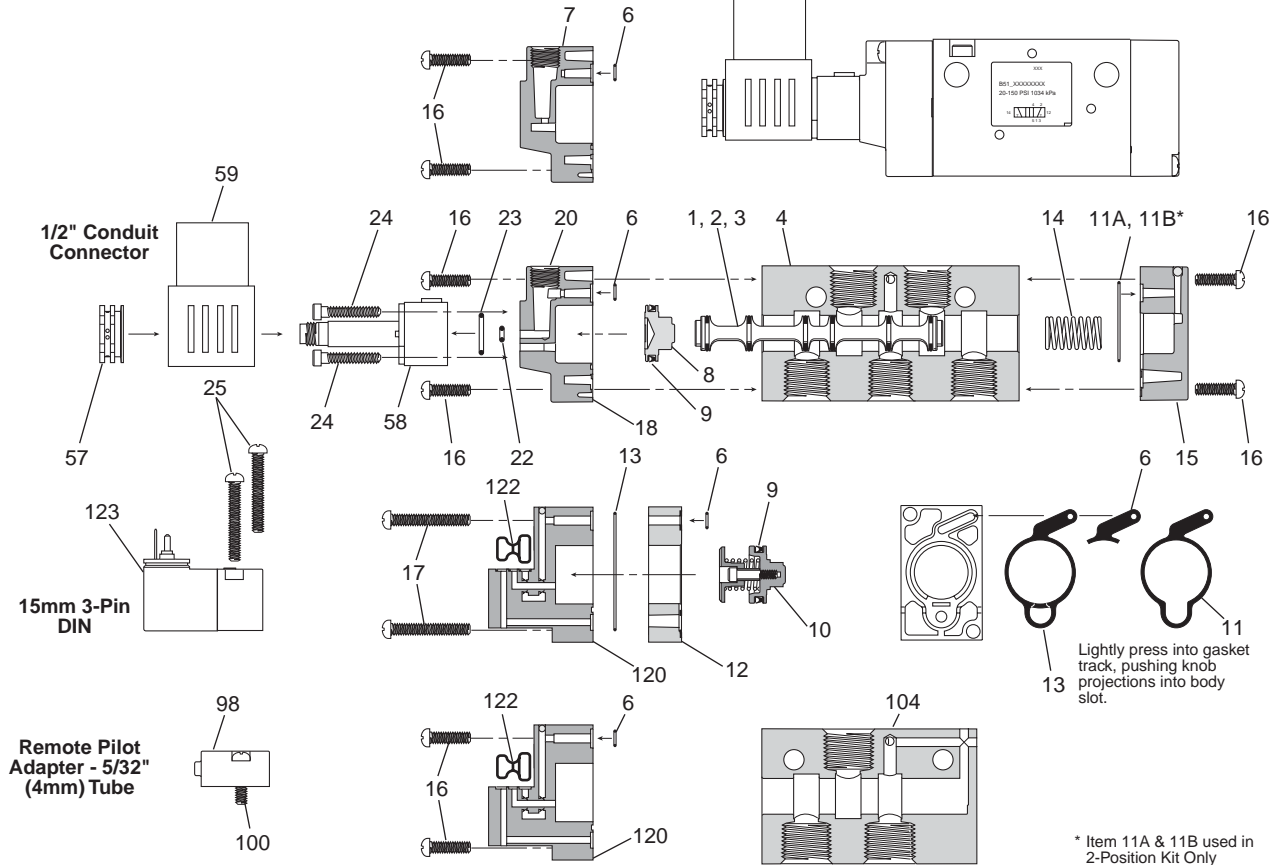
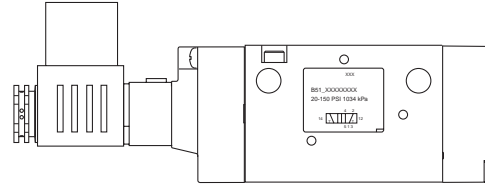
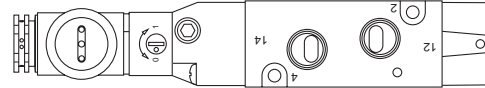
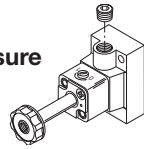

Item List – Parts not sold separately.

Item	Description	Item	Description	Item	Description
1*	Spool Seal	14*	Spring, Return Assist	58a*	Solenoid Base Assembly - Locking
2*	Spool - 2-Position (Seals Assembled)	15a	Return Operator	58b*	Solenoid Base Assembly - Non Locking
3*	Spool - 3-Position (Seals Assembled)	15b	Return Operator - CSA Option	59*	Coil - Alternate Enclosure (see Page C51)
4	Inline Body - 4-Way	16*	Screws - Operator Adapter - 2-Position	98*	Remote Pilot Adapter - 5/32" Tube (PVAP111)
6*	Gasket - Body to Operator	17*	Screws - Operator Adapter - 3-Position	100	Screws - Remote Pilot Adapter
7	Remote Pilot Operator	18*	Operator Adapter - Alt Enclosure	104	Inline Body - 3-Way
8	Operator Piston - 2-Position	20*	1/8" NPT Pipe Plug	120a	Solenoid Adapter - Vent Exhaust
9*	Lip Seal - Operator Piston	22*	O-ring - Small - Solenoid Base	120b	Solenoid Adapter - Tapped Exhaust
10	Operator Piston Mechanism - 3-Position	23*	O-ring - Large - Solenoid Base	120c	Solenoid Adapter - Ext Pilot. Vent Exhaust
11A*	Gasket - Body to Return Cap	24*	Bolts - Solenoid Base	120d	Solenoid Adapter - Ext Pilot. Tapped Exhaust
11B*	O-ring - Body to Operator (Effective Feb. 2008)	25*	Self Tapping Screw - Solenoid (Effective Jan 00)	122*	Gasket - Solenoid to Adapter
12	Adapter - 3-Position	57*	Solenoid Nut	123*	15mm Solenoid
13	Gasket - 3-Position Adapter to Body				

Note: * Parts are available in kits shown. For kit components, order VALVE LESS SOLENOID for assembled and tested repair valve.



For inventory, lead times, and kit lookup, visit www.pdnplu.com

B7A / B8A Series

Spool / Body Service Kits

PS2501P	4-Way, 2-Pos	Item 2, 6 (2), 9 (2), 11, grease packet
PS2502P	4-Way, 3-Pos APB	Item 3, 6 (2), 9 (2), 13 (2), grease packet
PS2503P	4-Way, 3-Pos CE	Item 3, 6 (2), 9 (2), 13 (2), grease packet
PS2504P	4-Way, 3-Pos PC	Item 3, 6 (2), 9 (2), 13 (2), grease packet
PS257101P	3-Way, 2-Pos. NC	Item 2, 6, 9, grease packet
PS257102P	3-Way, 2-Pos. NO	Item 2, 6, 9, grease packet

Kit Includes:

Armature / Override Kit –

Kit Includes: Item 22, 23, 24 (2), 57, 58 Assembled



* Comes with a Thru Nut and A Diffuser Nut.

Valve to Manifold Kits

PS2584P	O-ring (10) - Inline Valve to IEM Manifold
PS2587P	Mounting Bolts (10) - Inline Valve

Solenoid Kit *Kit Includes:* 25, 122, 123

PS2982*##P	3-Pin, EN175301-803, 15mm
PS3541*##P	3-Pin, EN175301-803, 15mm Option 2

Pilot Replacement Kit – Alternate Enclosure

Kit Includes: Item 6, 8, 9, 10, 16 (4), 18, 20, 22, 23, 24 (2), 57, 58 Assembled

PS2597GBP	Non-Locking, BSPP
PS2597GCP	Locking, BSPP
PS2597NBP	Non-Locking, NPT
PS2597NCP	Locking, NPT

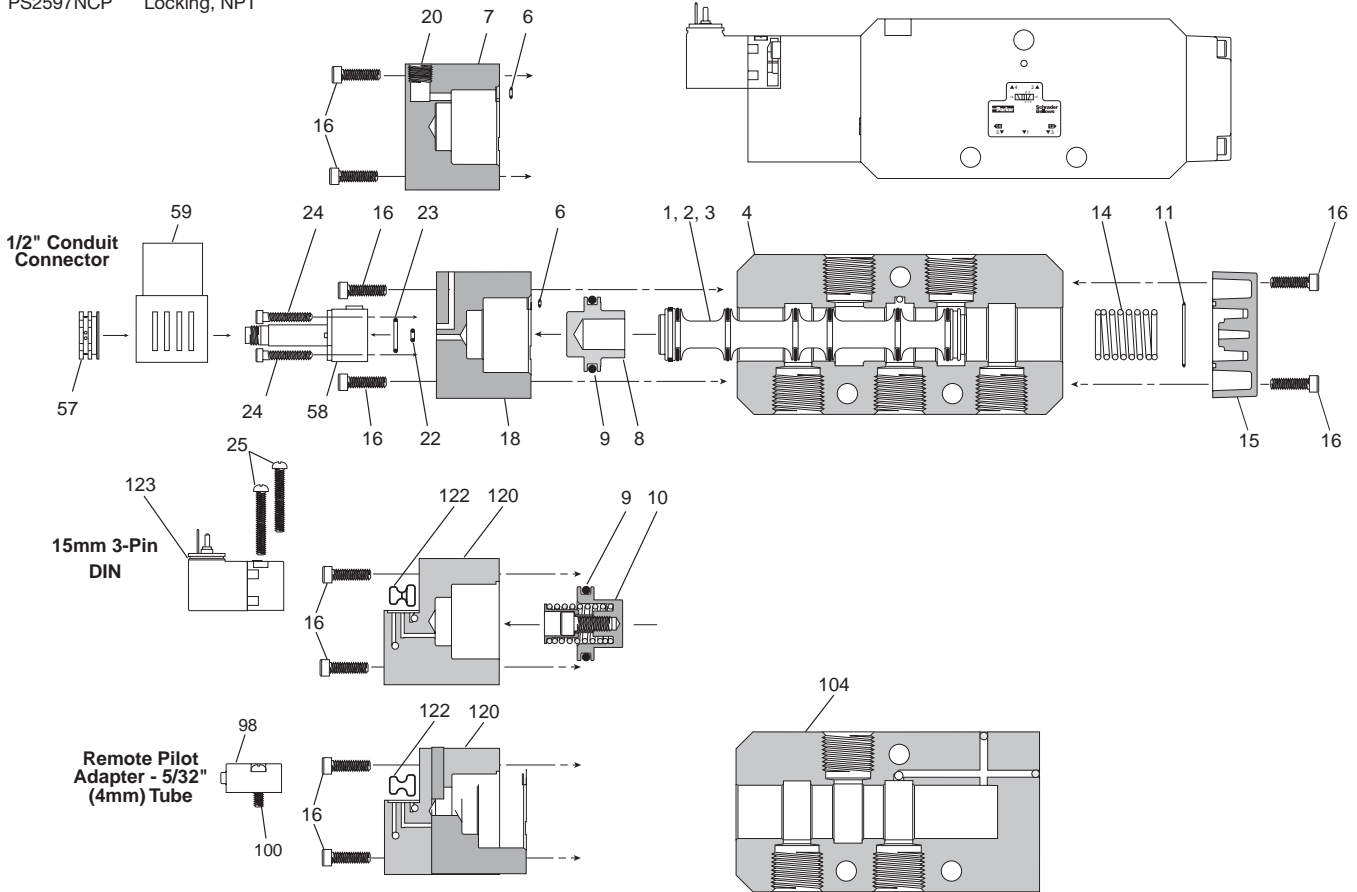

Item List – Parts not sold separately.

Item	Description	Item	Description	Item	Description
1*	Spool Seal	15a	Return Operator	58b*	Solenoid Base Assembly - Non Locking
2*	Spool - 2-Position (Seals Assembled)	16*	Screws - Operator Adapter	59*	Coil - Alternate Enclosure (see Page C51)
3*	Spool - 3-Position (Seals Assembled)	8*	Operator Adapter - Alt Enclosure	98*	Remote Pilot Adapter - 5/32" Tube (PVAP111)
4	Inline Body - 4-Way	20*	1/8" NPT Pipe Plug	100	Screws - Remote Pilot Adapter
6*	Gasket - Body to Operator	22*	O-ring - Small - Solenoid Base	104	Inline Body - 3-Way
7	Remote Pilot Operator	23*	O-ring - Large - Solenoid Base	120a	Solenoid Adapter - Vent Exhaust
8	Operator Piston - 2-Position	24*	Bolts - Solenoid Base	120b	Solenoid Adapter - Tapped Exhaust
9*	Lip Seal - Operator Piston	25*	Self Tapping Screw - Solenoid (Effective Jan 00)	120c	Solenoid Adapter - Ext Pilot. Vent Exhaust
10	Operator Piston Mechanism - 3-Position	57*	Solenoid Nut	120d	Solenoid Adapter - Ext Pilot. Tapped Exhaust
11*	Gasket - Body to Return Cap	58a*	Solenoid Base Assembly - Locking	122*	Gasket - Solenoid to Adapter
14*	Spring, Return Assist			123*	15mm Solenoid

Note: * Parts are available in kits shown. For kit components, order VALVE LESS SOLENOID for assembled and tested repair valve.



For inventory, lead time, and kit lookup, visit www.pdnplu.com

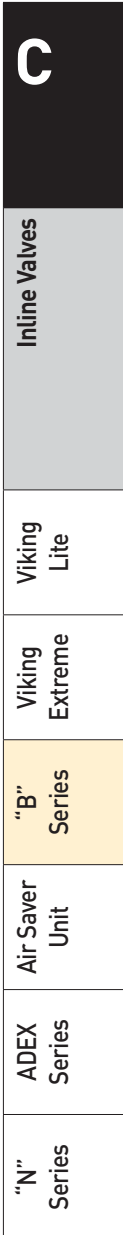

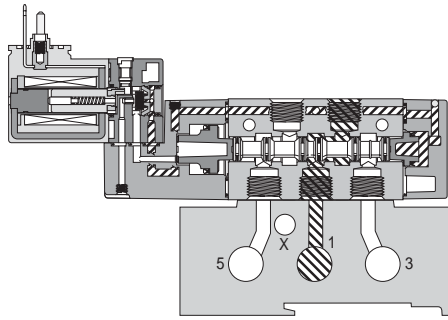

B3 Single Solenoid IEM Aluminum Bar Manifold
 Shown De-Energized

Single Solenoid
3-Way, 2-Position
NC (NPP)

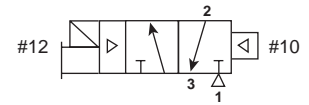

Normally Closed:

De-energized position – Solenoid #12 de-energized. Pressure at inlet port 1 blocked, outlet port 2 connected to exhaust port 3.

Energized position – Solenoid #12 energized. Pressure at inlet port 1 connected to outlet port 2, exhaust port 3 is blocked.

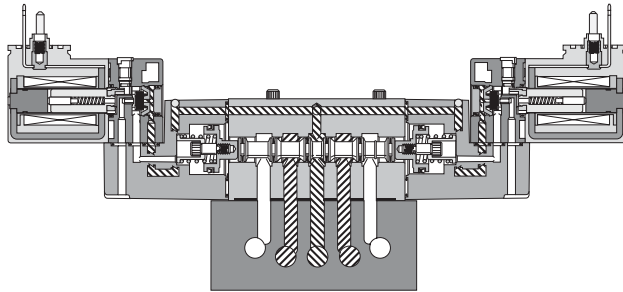

B3 Double Solenoid 3-Position Subbase Mounted
 Shown De-Energized

Single Solenoid
3-Way, 2-Position
NO (NP)

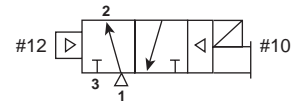

Normally Open:

De-energized position – Solenoid #10 de-energized. Pressure at inlet port 1 connected to outlet port 2, exhaust port 3 is blocked.

Energized position – Solenoid #10 energized. Pressure at inlet port 1 blocked, outlet port 2 connected to exhaust port 3.

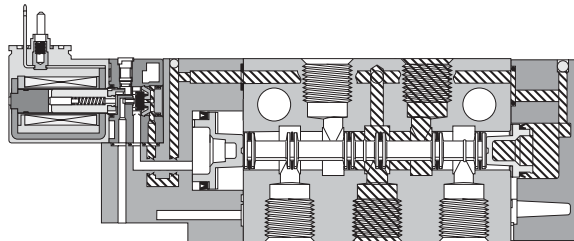

B5 Single Solenoid Inline - Air Return
 Shown De-Energized

3-Way Configuration

B6, B7, B8:

Looking at the #1 and #3 ports, the solenoid (or remote operator) is always on the #3 port end. Different spools are used for NO and NC functions.

B3, B5:

Looking at the #1 and #3 ports, the solenoid (or remote operator) is on the #3 port end for NC and the #1 port end for NO. The same spool is used for both.

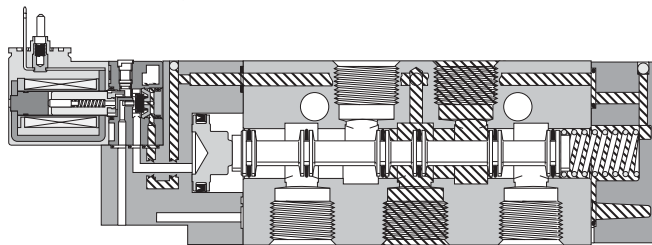

B6, B7 & B8 Single Solenoid Inline - Spring / Air Return
 Shown De-Energized

Pressure Exhaust

C	Inline Valves
	Viking Lite
Viking Extreme	"B" Series
	Air Saver Unit
ADEX Series	"N" Series

B3 Single & Double Operators – 4-way Inline

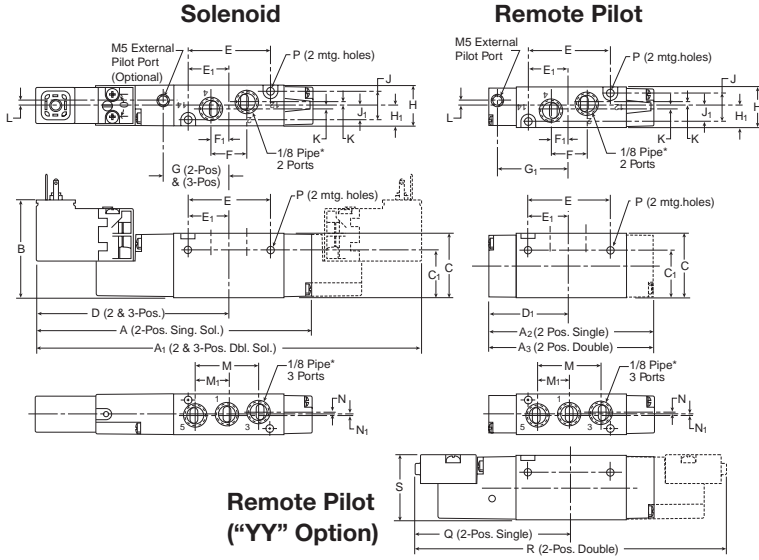

B3 4-way Inline

A 4.67 (119)	A1 6.44 (164)	A2 3.12 (79)	A3 3.33 (85)	B 1.66 (42)
C 1.13 (39)	C1 .84 (21)	D 3.22 (82)	D1 1.66 (42)	E 1.47 (37)
E1 .74 (19)	F .63 (16)	F1 .32 (8)	G 1.13 (29)	G1 1.50 (38)
H .71 (18)	H1 .36 (9)	J .51 (13)	J1 .26 (7)	K .06 (2)
L .11 (3)	M 1.12 (28)	M1 .56 (14)	N .05 (1)	N1 .05 (1)
P ∅ .13 ∅ (3.3)	Q 2.69 (68)	R 5.37 (136)	S 1.16 (29)	

Inches (mm)

B3 Single & Double Operators – 3-way Inline

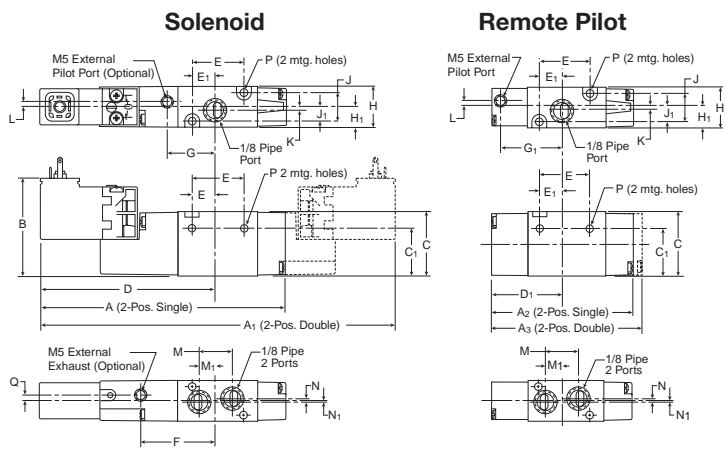

B3 3-way Inline

A 4.20 (107)	A1 5.96 (151)	A2 2.65 (67)	A3 2.86 (73)	B 1.66 (42)
C 1.13 (39)	C1 .84 (21)	D 2.93 (74)	D1 1.38 (35)	E .98 (25)
E1 .44 (11)	F 1.32 (34)	G .85 (22)	G1 1.22 (31)	H .71 (18)
H1 .36 (9)	J .51 (13)	J1 .26 (7)	K .06 (2)	L .11 (3)
M .63 (16)	M1 .27 (7)	N .12 (3)	N1 .06 (2)	P ∅ .13 ∅ (3.3)
Q .08 (2)				

Inches (mm)

B3 Single & Double Operators – 4-way Face Mount

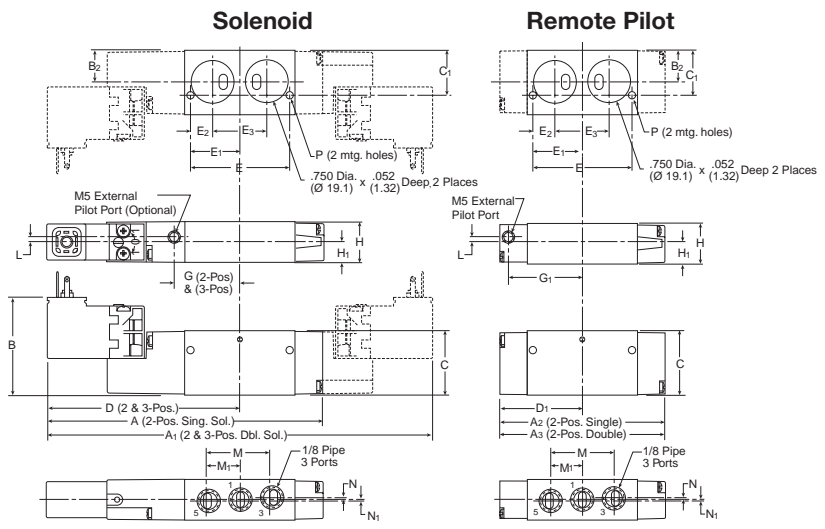

B3 4-way Face Mount

A 4.67 (119)	A1 6.44 (164)	A2 3.12 (79)	A3 3.33 (85)	B 1.66 (42)
B2 .58 (15)	C 1.13 (29)	C1 .81 (21)	D 3.22 (82)	D1 1.66 (42)
E 1.74 (44)	E1 .87 (22)	E2 .39 (10)	E3 .95 (24)	G 1.13 (29)
G1 1.50 (38)	H .71 (18)	H1 .36 (9)	L .11 (3)	M 1.12 (28)
M1 .56 (14)	N .05 (1)	N1 .05 (1)	P ∅ .13 ∅ (3.3)	

Inches (mm)

C
Inline Valves
Viking Lite
Viking Extreme
"B" Series
Air Saver Unit
ADEX Series
"N" Series



For inventory, lead time, and kit lookup, visit www.pdnplu.com

C61

Parker Hannifin Corporation
 Pneumatic Division
 Richland, Michigan
www.parker.com/pneumatics

B3 Single & Double Operators – 4-way IEM Stackable

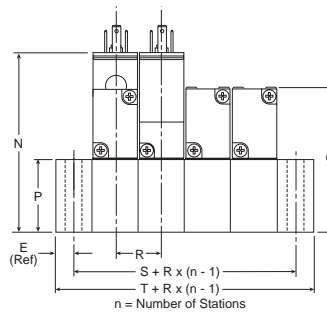
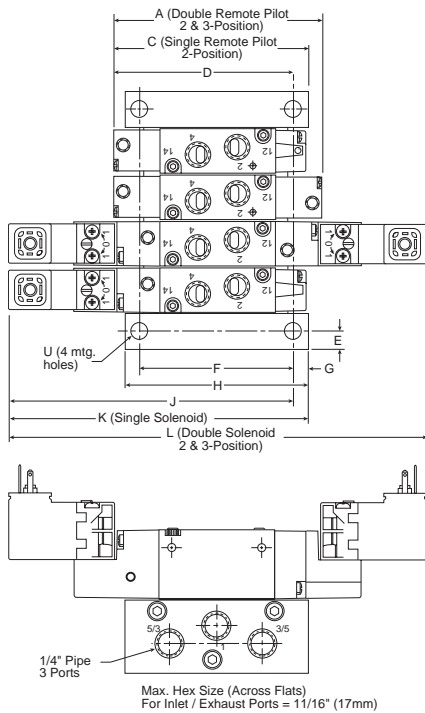

B3 4-way IEM Stackable

A	C	D	E	F
3.33 (84.6)	3.12 (79.2)	2.91 (73.9)	.30 (7.6)	2.49 (63.3)
G	H	J	K	L
.25 (6.4)	3.00 (76.2)	4.46 (113.3)	4.67 (118.6)	6.43 (163.3)
N	P	Q	R	
2.91 (73.9)	1.25 (31.8)	2.38 (60.5)	.74 ±.01 (18.8) ± .3	
S	T	U		
1.34 (34.0)	1.94 (49.3)	Ø .28 Ø (7.1)		

Inches (mm)

B3 Single & Double Operators – 4-way IEM Aluminum Bar

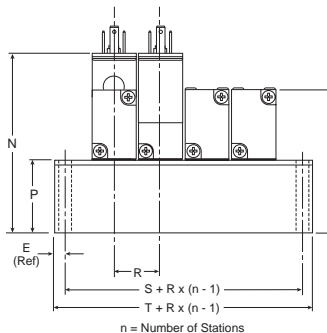
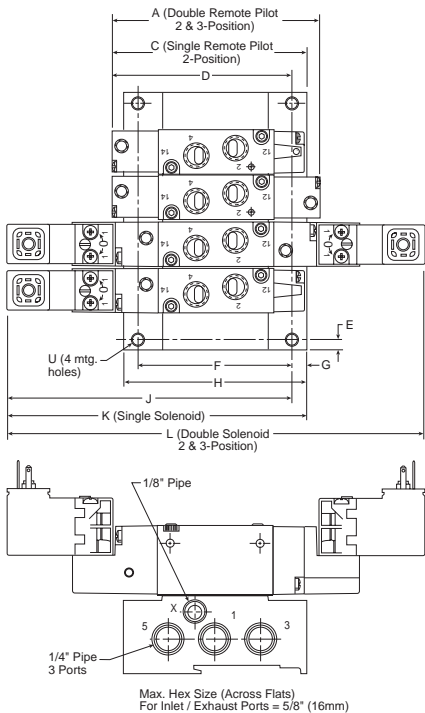

B3 4-way IEM Aluminum Bar Manifold

A	C	D	E	F
3.33 (84.6)	3.17 (80.5)	2.94 (74.7)	.25 (6.4)	2.54 (64.5)
G	H	J	K	L
.23 (5.9)	3.00 (76.2)	4.50 (114.2)	4.73 (120.1)	6.43 (163.3)
N	P	Q	R	S
2.94 (74.7)	1.28 (32.5)	2.41 (61.2)	.81 (20.5)	1.13 (28.8)
T	U			
1.64 (41.6)	Ø .23 Ø (5.8)			

Inches (mm)

- C**
- Inline Valves
- Viking Lite
- Viking Extreme
- Series "B"
- Air Saver Unit
- ADEX Series
- "N" Series



For inventory, lead times, and kit lookup, visit www.pdnplu.com

B3 Single & Double Operators – 3-way IEM Aluminum Bar

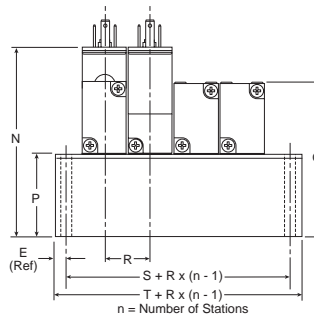
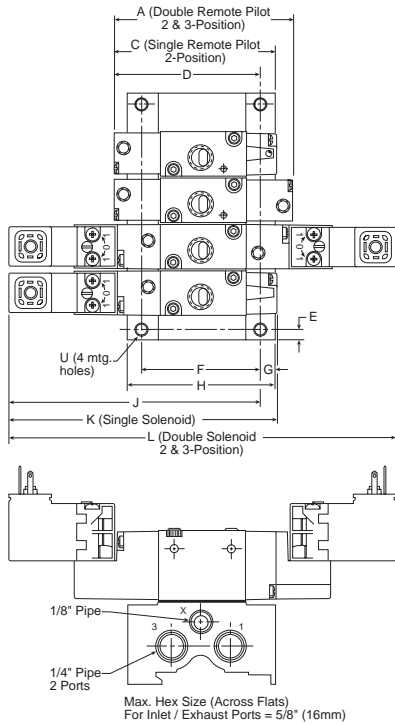

B3 4-way IEM Aluminum Bar Manifold

A	C	D	E	F
2.86 (72.6)	2.65 (67.3)	2.33 (59.2)	.25 (6.4)	1.80 (45.7)
G	H	J	K	L
.23 (5.9)	2.25 (57.2)	3.88 (98.6)	4.20 (106.7)	5.96 (151.4)
N	P	Q	R	S
2.93 (74.5)	1.27 (32.4)	2.40 (61.1)	.81 (20.5)	1.13 (28.8)
T	U			
1.64 (41.6)	Ø .23 (5.8)			

Inches (mm)

B3 Single & Double Operators (– 4-way Single Subbase

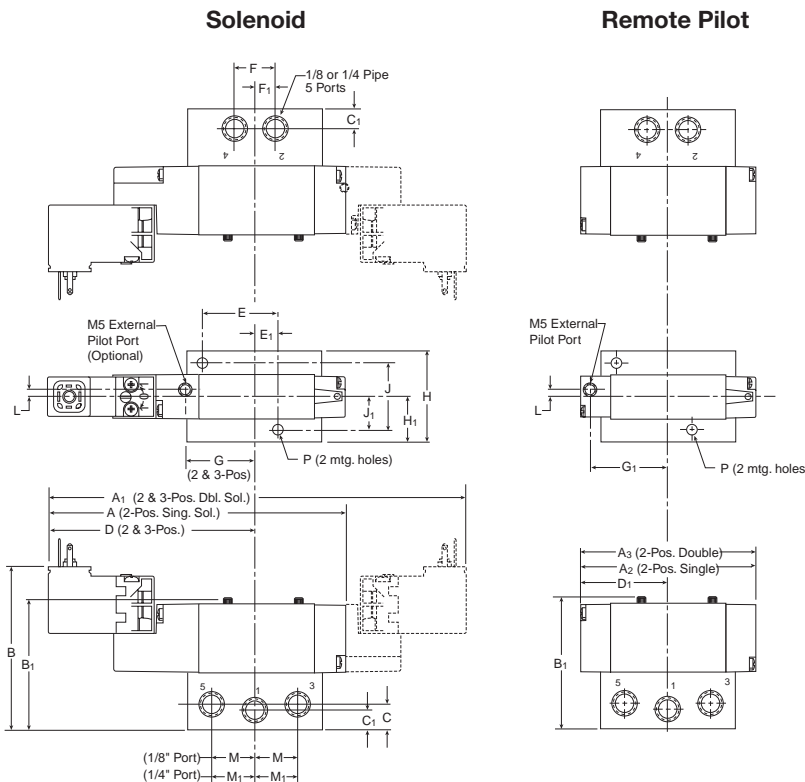

B3 4-way Single Subbase

A	A ₁	A ₂	A ₃	B
4.67 (119)	6.44 (164)	3.12 (79)	3.33 (85)	2.63 (67)
B ₁	C	C ₁	D	D ₁
2.21 (56)	.47 (12)	.37 (9)	3.22 (82)	1.66 (42)
E	E ₁	F	F ₁	G
1.25 (32)	.38 (10)	.69 (18)	.34 (9)	1.13 (29)
G ₁	H	H ₁	J	J ₁
1.50 (38)	1.50 (38)	.75 (19)	1.12 (28)	.56 (14)
L	M	M ₁	P	
.11 (3)	.71 (18)	.76 (19)	Ø .18 (4)	Ø (4)

Inches (mm)

C

Inline Valves

Viking Lite

Viking Extreme

"B" Series

Air Saver Unit

ADEX Series

"N" Series



For inventory, lead time, and kit lookup, visit www.pdnplu.com

C63

Parker Hannifin Corporation
 Pneumatic Division
 Richland, Michigan
www.parker.com/pneumatics

B3 Single & Double Operators – 5-port Subbase Bar Manifold

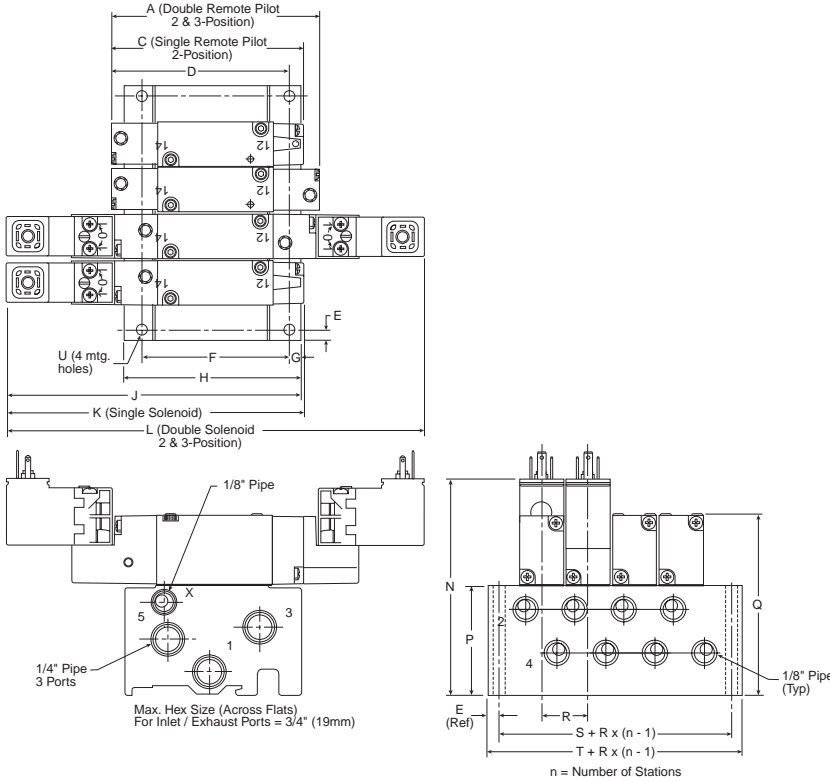

B3 5-port Subbase Bar Manifold

A	C	D	E	F
3.33 (84.6)	3.12 (79.2)	2.88 (73.2)	.25 (6.3)	2.43 (61.7)
G	H	J	K	L
.22 (5.5)	2.93 (74.5)	4.66 (118.3)	4.67 (118.6)	6.43 (166.3)
N	P	Q	R	S
3.47 (88.2)	1.81 (46.0)	2.94 (74.7)	.81 (20.5)	1.39 (35.4)
T	U			
1.89 (48.0)	Ø .22 Ø (5.6)			

Inches (mm)

B5 Single & Double Operators – 4-way Inline

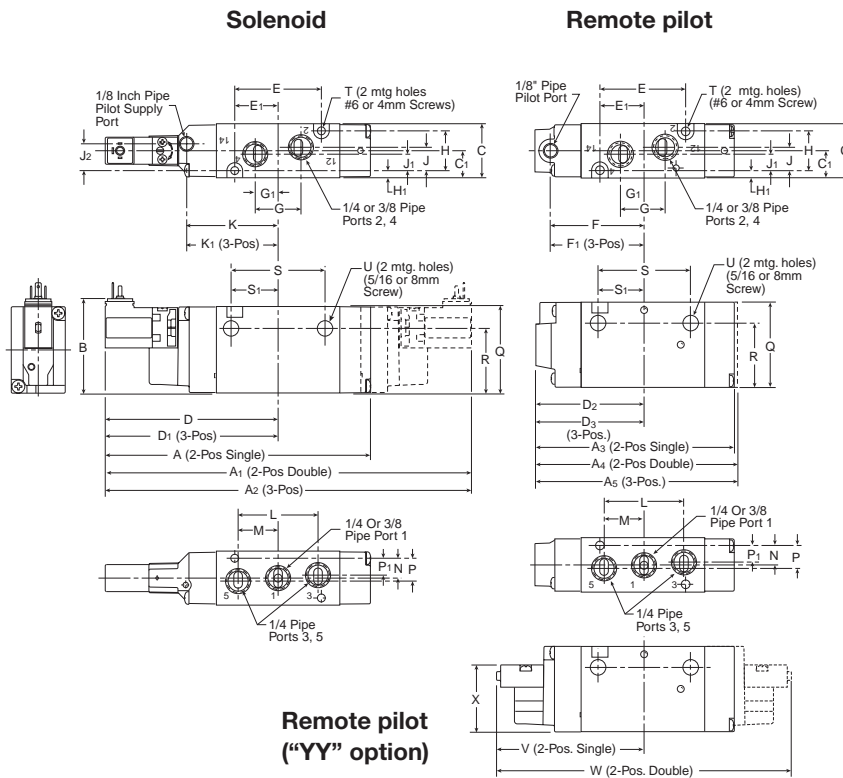

B5 4-way Inline

A	A1	A2	A3	A4
5.78 (147)	7.51 (191)	8.45 (215)	4.37 (110)	4.70 (119)
A5	B	C	C1	D
5.64 (143)	2.06 (52)	1.18 (30)	.59 (15)	3.76 (96)
D1	D2	D3	E	E1
4.23 (107)	2.35 (60)	2.82 (72)	1.89 (48)	.95 (24)
F	F1	G	G1	H
2.01 (51)	2.47 (63)	1.00 (25)	.50 (13)	.87 (22)
H1	J	J1	J	K
.16 (4)	.51 (13)	.36 (9)	.58 (15)	2.00 (51)
K1	L	M	N	P
2.47 (63)	1.75 (44)	.88 (22)	.43 (48)	.50 (13)
P1	Q	R	S	S1
.37 (92)	1.89 (48)	1.41 (36)	2.05 (52)	1.03 (26)
T	U	V	W	X
Ø .177 Ø (4.5)	Ø .34 Ø (9)	3.24 (82)	6.48 (165)	1.50 (383)

Inches (mm)



For inventory, lead times, and kit lookup, visit www.pdnplu.com

B5 Single & Double Operators – 3-way Inline

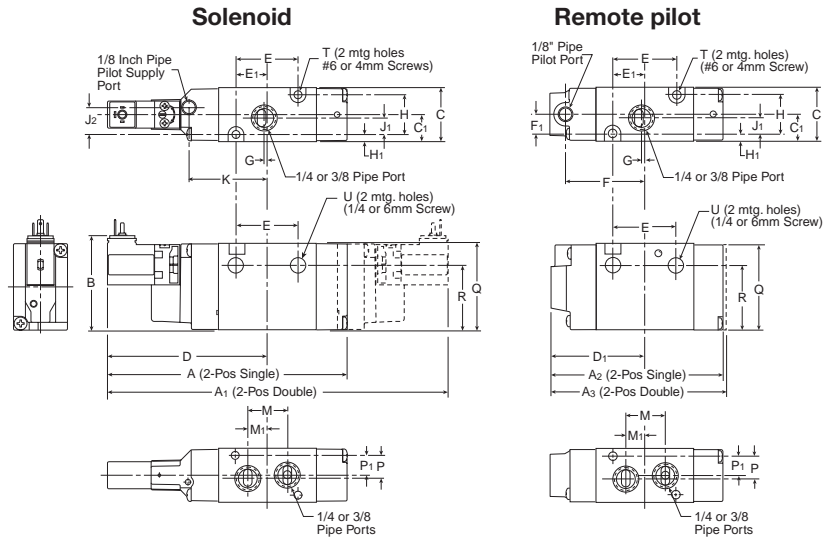

B5 3-way Inline

A 5.29 (134)	A₁ 7.03 (179)	A₂ 3.88 (99)	A₃ 4.21 (107)	B 2.06 (52)
C 1.18 (30)	C₁ .59 (15)	D 3.43 (87)	D₁ 2.11 (54)	E 1.40 (36)
E₁ .70 (18)	F 1.77 (45)	F₁ .43 (11)	G .06 (2)	H .87 (22)
H₁ .16 (4)	J₁ .36 (9)	J₂ .58 (15)	K 1.67 (42)	M .88 (22)
M₁ .44 (11)	P .50 (13)	P₁ .37 (9)	Q 1.89 (48)	R 1.41 (36)
T Ø .177 Ø (4.5)	U Ø .26 Ø (6.6)			

Inches (mm)

B5 Single & Double Operators – 4-way NAMUR Mount

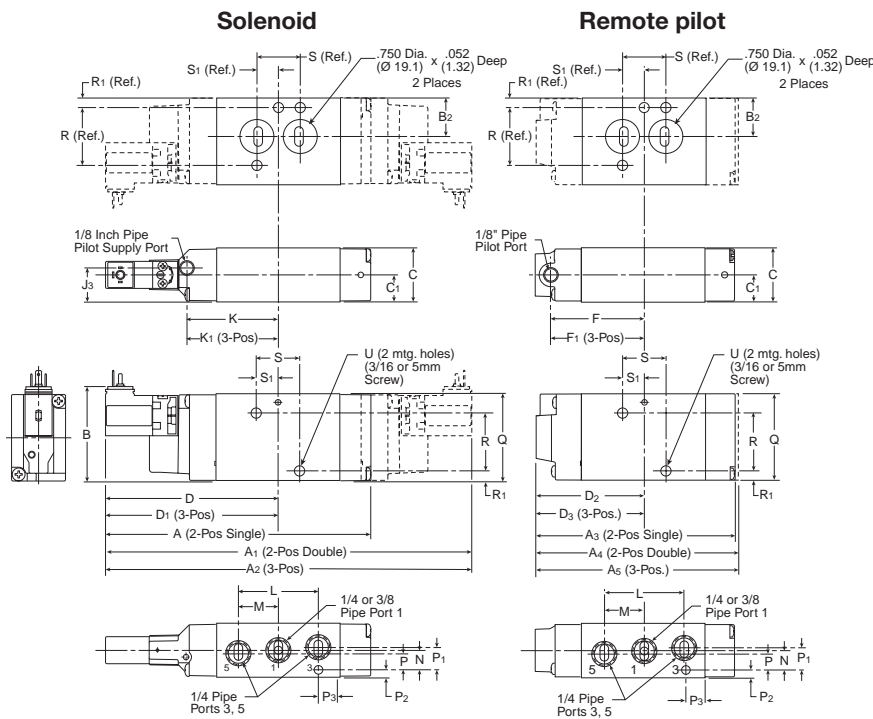

B5 4-way NAMUR Mount

A 5.78 (147)	A₁ 7.51 (191)	A₂ 8.45 (215)	A₃ 4.37 (110)	A₄ 4.70 (119)
A₅ 5.64 (143)	B 2.06 (52)	B₂ .84 (21)	C 1.18 (30)	C₁ .59 (15)
D 3.76 (96)	D₁ 4.23 (107)	D₂ 2.35 (60)	D₃ 2.82 (72)	F 2.01 (51)
F₁ 2.47 (63)	J₃ .74 (19)	K 2.00 (51)	K₁ 2.47 (63)	L 1.75 (44)
M .88 (22)	N .44 (11)	P .37 (9.4)	P₁ .50 (13)	P₂ .16 (4)
P₃ .40 (10)	Q 1.89 (48)	R 1.26 (32)	R₁ .21 (5)	S .94 (24)
S₁ .47 (12)	U Ø .224 Ø (5.7)			

Inches (mm)

B5 Alternative Electrical Enclosure Option F

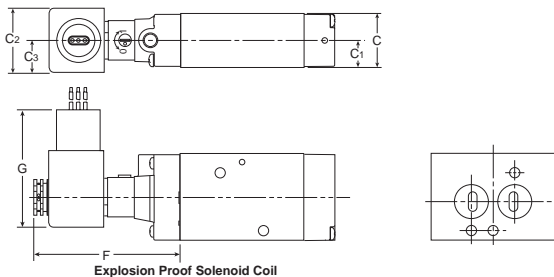

B5 4-way NAMUR Mount with Option F Enclosure

C 1.18 (30)	C₁ .59 (15)	C₂ 1.42 (36)	C₃ .71 (18)	F 3.15 (80)
G 2.60 (66)				

Inches (mm)



For inventory, lead time, and kit lookup, visit www.pdnplu.com

C65

Parker Hannifin Corporation
 Pneumatic Division
 Richland, Michigan
www.parker.com/pneumatics

C

Inline Valves

Viking Lite

Viking Extreme

"B" Series

Air Saver Unit

ADEX Series

"N" Series

B5 Single & Double Operators – 4-way IEM Stackable

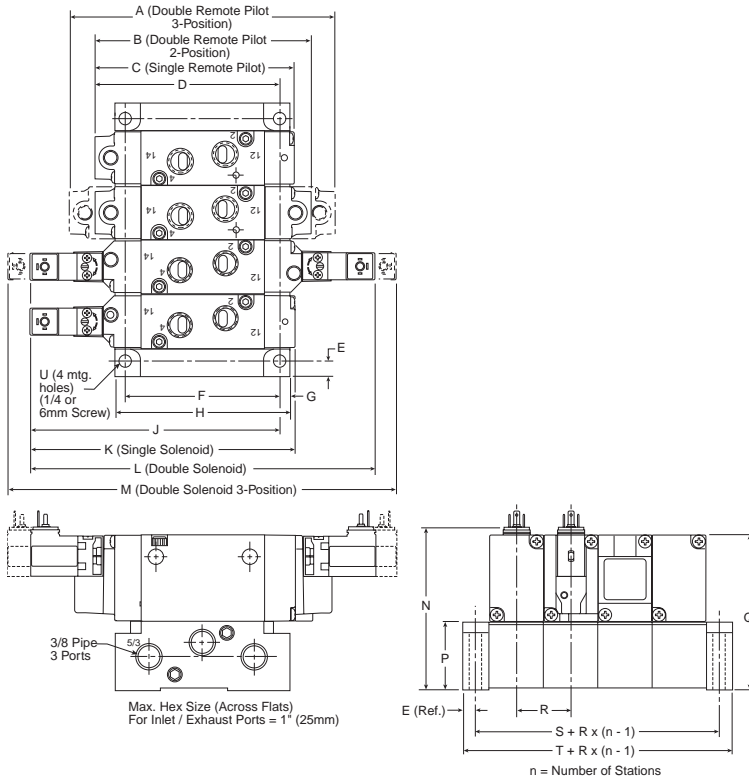

B5 4-way IEM Stackable

A	B	C	D	E
5.64 (143.3)	4.70 (119.4)	4.37 (110.0)	4.29 (109.0)	.29 (7.4)
F	G	H	J	K
3.44 (87.4)	.24 (6.1)	3.92 (99.6)	5.48 (139.2)	5.78 (146.8)
L	M	N	P	Q
7.52 (191.0)	8.46 (214.9)	3.56 (90.4)	1.50 (38.1)	3.42 (86.9)
R	S	T	U	
1.21 ± .01 (30.7) ± (.3)	1.79 (45.5)	2.37 (60.2)	Ø .28 (7.1)	

Inches (mm)

B5 Single & Double Operators – 4-way Single Subbase

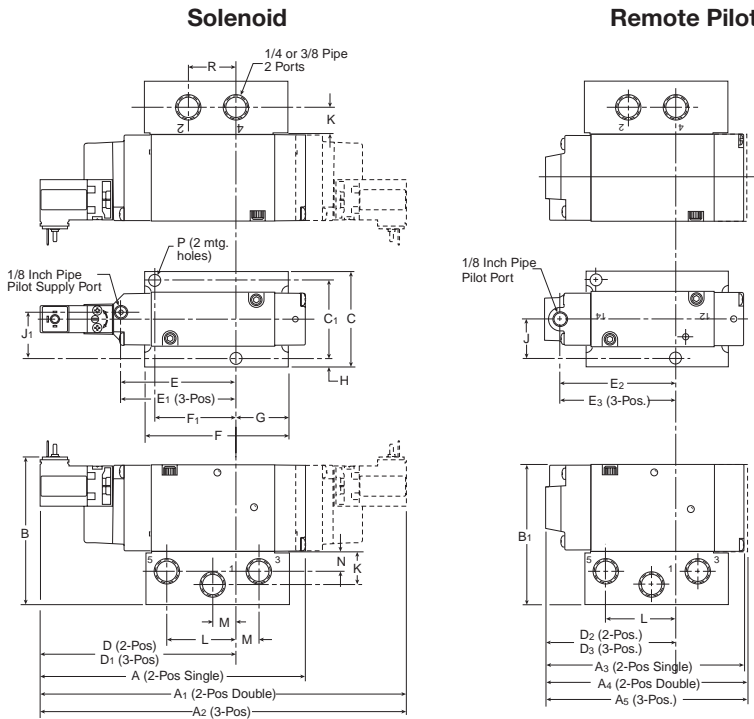

B5 4-way Subbase

A	A ₁	A ₂	A ₃	A ₄
5.78 (147)	7.52 (191)	8.46 (215)	4.37 (110)	4.70 (119)
A ₅	B	B ₁	C	C ₁
5.64 (143)	3.21 (82)	3.03 (77)	2.12 (54)	1.69 (43)
D	D ₁	D ₂	D ₃	E
4.26 (108)	4.73 (120)	2.85 (72)	3.32 (40)	2.51 (65)
E ₁	E ₂	E ₃	F	F ₁
2.98 (76)	2.60 (66)	3.07 (80)	2.90 (74)	1.69 (43)
G	H	J	J ₁	K
.95 (24)	.22 (5)	.84 (21)	.99 (25)	.71 (18)
L	M	N	P	R
1.50 (38)	.50 (13)	.46 (12)	Ø .27 (7)	1.00 (25)

Inches (mm)



For inventory, lead times, and kit lookup, visit www.pdnplu.com

B5 Single & Double Operators – 4-way IEM Aluminum Bar

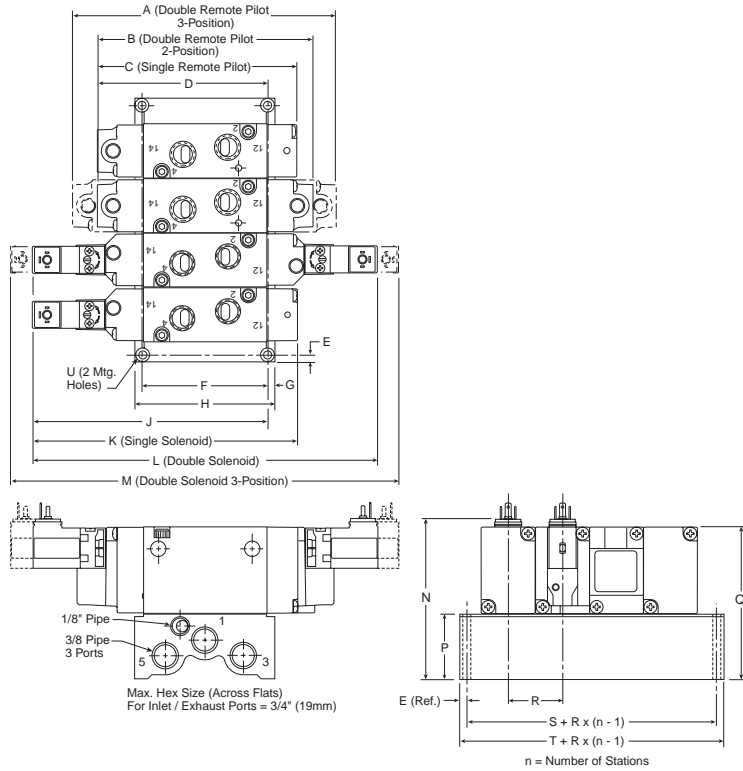

B5 4-way IEM Aluminum Bar Manifold

A	B	C	D	E
5.64 (143.3)	4.70 (119.4)	4.37 (110.0)	3.74 (95.0)	.18 (4.6)
F	G	H	J	K
2.78 (70.6)	.17 (4.3)	3.12 (79.2)	5.15 (130.8)	5.78 (146.8)
L	M	N	P	Q
7.52 (191.0)	8.46 (214.9)	3.50 (89.0)	1.44 (36.6)	3.36 (85.3)
R	S	T	U	
1.26 (32.0)	1.78 (45.2)	2.14 (54.4)	Ø .22 Ø (5.5)	

Inches (mm)

B5 Single & Double Operators – 3-way IEM Aluminum Bar

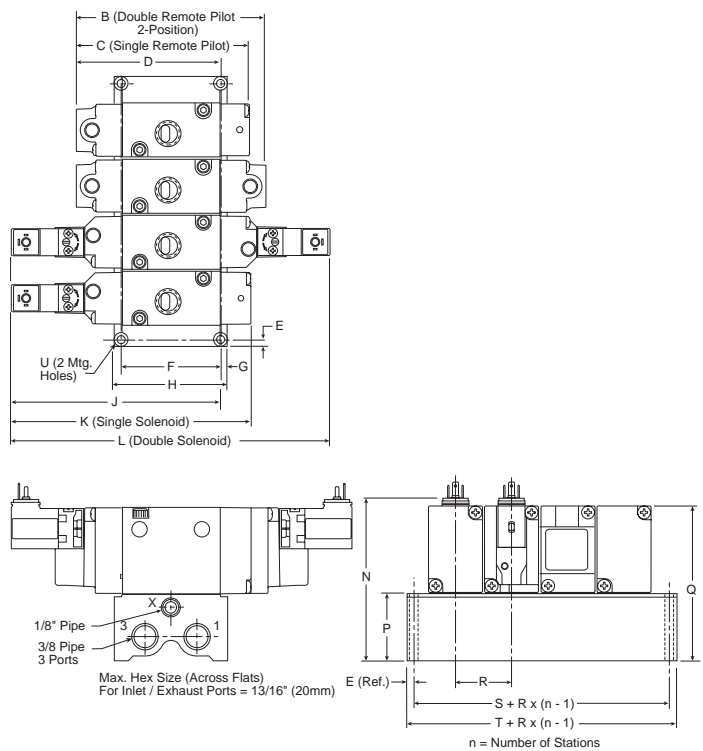

B5 3-way IEM Aluminum Bar Manifold

B	C	D	E	F
4.21 (106.9)	3.88 (98.6)	3.41 (86.6)	.18 (4.6)	2.12 (53.8)
G	H	J	K	L
.17 (4.3)	2.46 (62.5)	4.82 (122.4)	5.29 (134.4)	7.03 (178.6)
N	P	Q	R	S
3.50 (89.0)	1.44 (36.6)	3.36 (85.3)	1.26 (32.0)	1.76 (44.7)
T	U			
2.12 (53.8)	Ø .18 Ø (4.6)			

Inches (mm)

C	Inline Valves
	Viking Lite
Viking Extreme	
"B" Series	
Air Saver Unit	
ADEX Series	
"N" Series	



For inventory, lead time, and kit lookup, visit www.pdnplu.com

B5 3 & 4-way Alternative Electrical Enclosures

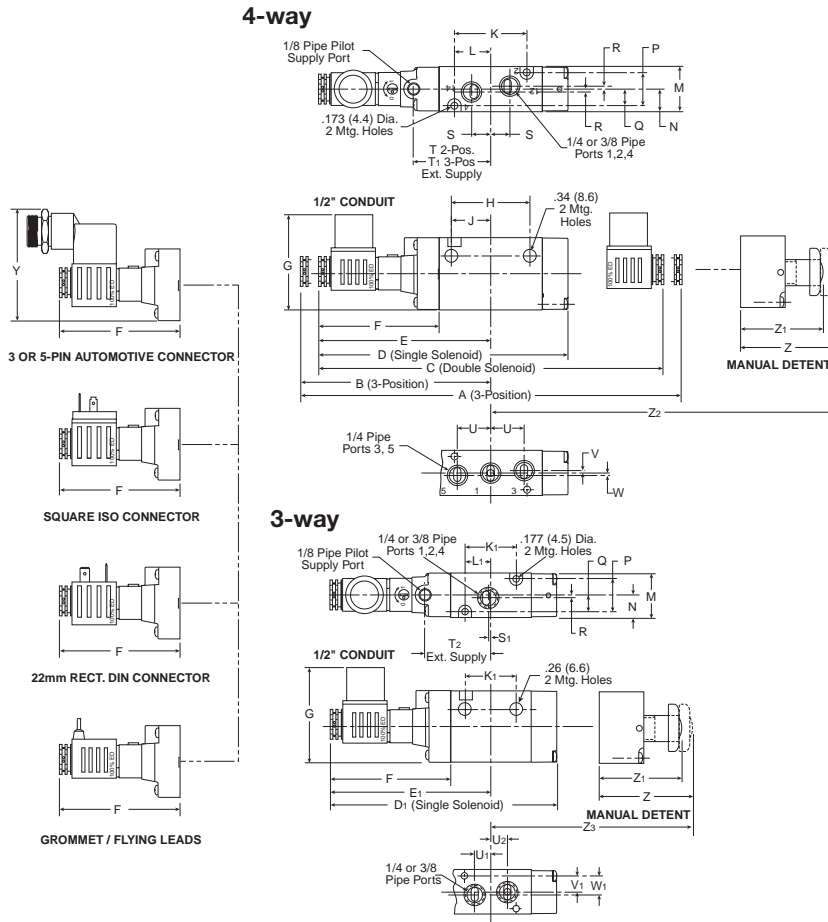

B5 Alternative – Electrical Enclosures

A	A1	B	C	D
9.94 (252.5)	.872 (221.4)	4.97 (126.2)	9.00 (228.6)	6.52 (165.6)
D1	E	E1	F	G
6.02 (152.9)	4.50 (114.3)	4.26 (108.1)	3.15 (80.0)	2.47 (62.8)
H	J	K	K1	L
2.05 (52.1)	1.03 (26.2)	1.89 (48.0)	1.40 (35.5)	.95 (24.1)
L1	M	N	P	Q
.70 (17.8)	1.18 (30.0)	.59 (15.0)	.87 (22.1)	.43 (10.9)
R	S	S1	T	T1
.08 (2.0)	.50 (12.7)	.06 (1.5)	2.01 (51.1)	2.47 (62.7)
T2	U	U1	U2	V
1.76 (44.8)	.87 (22.1)	.43 (10.9)	.45 (11.3)	.06 (1.5)
V1	W	W1	Y	Z
.37 (9.3)	.07 (1.8)	.50 (13)	2.90 (73.6)	2.40 (60.9)
Z1	Z2	Z3		
2.12 (53.8)	3.75 (95.2)	4.17 (105.8)		

Inches (mm)

B6 Single & Double Operators – 4-way Inline

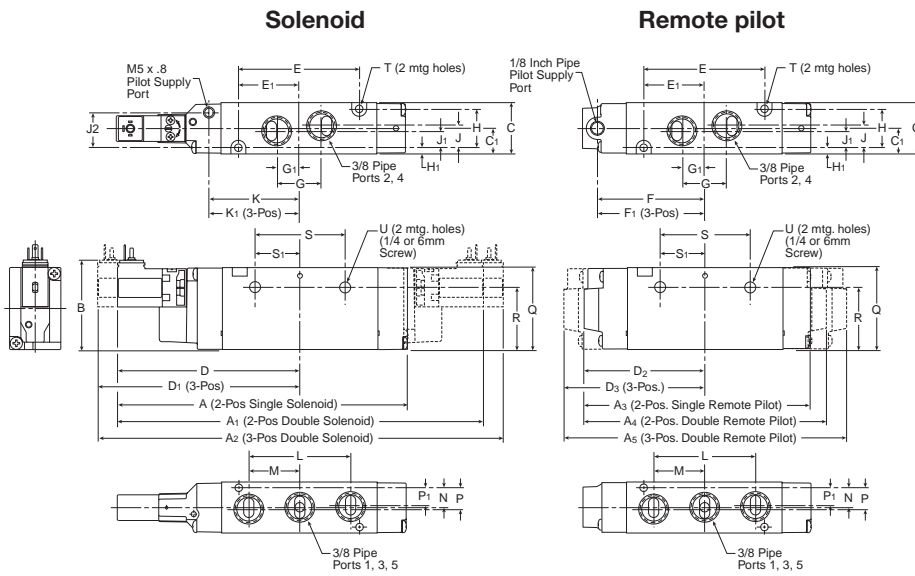

B6 4-way Inline

A	A1	A2	A3	A4
6.67 (169.5)	8.41 (213.7)	9.35 (237.6)	5.26 (133.7)	5.59 (142.1)
A5	B	C	C1	D
6.54 (166)	2.06 (52)	1.18 (30.0)	.59 (15)	4.21 (106.8)
D1	D2	D3	E	E1
4.68 (118.8)	2.80 (71)	3.27 (83.0)	2.79 (70.8)	1.39 (35.4)
F	F1	G	G1	H
2.45 (62.3)	2.92 (74.3)	1.03 (26.1)	.51 (13.1)	.91 (23)
H1	J	J1	J2	K
.14 (3.5)	.51 (13.1)	.39 (10)	.81 (20.6)	2.09 (53)
K1	L	M	N	P
2.56 (64.9)	2.34 (59.4)	1.17 (29.7)	.45 (11.5)	.49 (12.5)
P1	Q	R	S	S1
.41 (10.5)	1.89 (48)	1.45 (36.8)	2.09 (53)	1.04 (26.5)
T	U			
Ø .17 (4.4)	Ø .27 (6.9)			

Inches (mm)



For inventory, lead times, and kit lookup, visit www.pdnplu.com

C68

Parker Hannifin Corporation
 Pneumatic Division
 Richland, Michigan
www.parker.com/pneumatics

B6 Single Operators – 3-way Inline

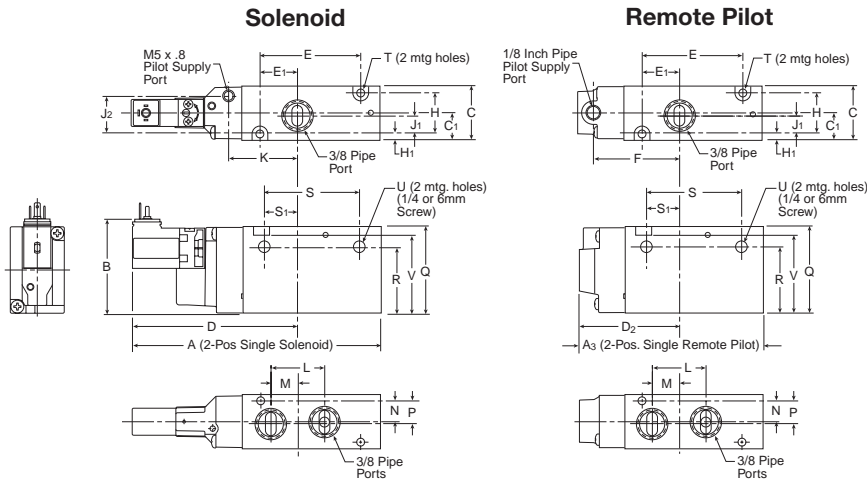

B6 3-way Inline

A	A3	B	C	C1
5.42 (137.7)	4.01 (101.9)	2.06 (52)	1.18 (30.0)	.59 (15.0)
D	D2	E	E1	F
3.63 (92.1)	2.22 (56.3)	2.19 (55.6)	0.82 (20.7)	1.87 (47.6)
H	H1	J1	J2	K
.91 (23.0)	.14 (3.5)	.39 (10.0)	.81 (20.6)	1.51 (38.3)
L	M	N	P	Q
1.17 (29.7)	.59 (15.0)	.45 (11.5)	.49 (12.5)	1.89 (48.0)
R	S	S1	T	U
1.45 (36.8)	2.09 (53.0)	0.76 (19.4)	Ø .17 Ø (4.4)	Ø .27 Ø (6.9)
V				
1.69 (43.0)				

Inches (mm)

B6 Single & Double Operators – 4-way NAMUR Mount

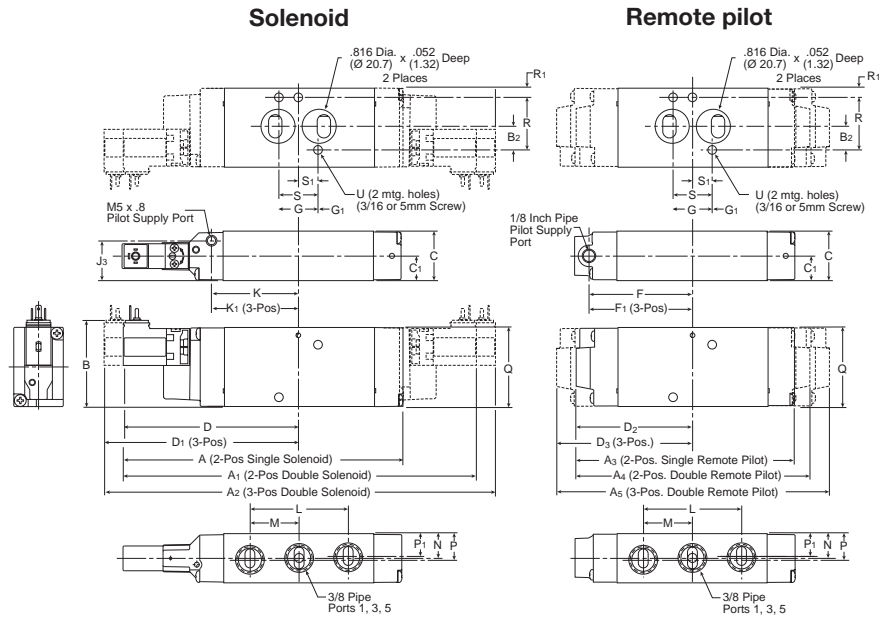

B6 4-way NAMUR Mount

A	A1	A2	A3	A4
6.67 (169.5)	8.41 (213.7)	9.35 (237.6)	5.26 (133.7)	5.59 (142.1)
A5	B	B2	C	C1
6.54 (166.0)	2.06 (52)	.57 (14.4)	1.18 (30.0)	.59 (15)
D	D1	D2	D3	F
4.21 (106.8)	4.68 (118.8)	2.80 (71.0)	3.27 (83.0)	2.45 (62.3)
F1	G	G1	J3	K
2.92 (74.3)	.95 (24.2)	.02 (0.53)	.95 (24.1)	2.09 (53.0)
K1	L	M	N	P
2.56 (64.9)	2.34 (59.4)	1.17 (29.7)	.59 (15)	.63 (16)
P1	Q	R	R1	S
.55 (14)	1.89 (48.0)	1.26 (32)	.22 (5.5)	.94 (24)
S1	T	U		
.47 (12)	Ø .17 Ø (4.4)	Ø .27 Ø (6.9)		

Inches (mm)

B6 Alternative Electrical Enclosure Option F

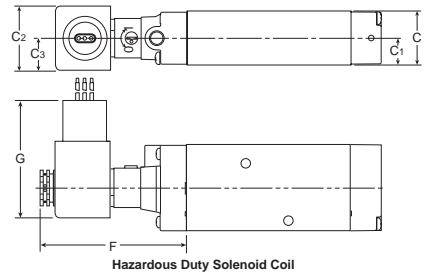

B6 4-way NAMUR Mount with Option F Enclosure

C	C1	C2	C3	F
1.18 (30)	.59 (15)	1.42 (36)	.71 (18)	3.15 (80)
G				
2.60 (66)				

Inches (mm)

C

Inline Valves

Viking Lite

Viking Extreme

"B" Series

Air Saver Unit

ADEX Series

"N" Series



For inventory, lead time, and kit lookup, visit www.pdnplu.com

B6 Single & Double Operators – 4-way IEM Aluminum Bar

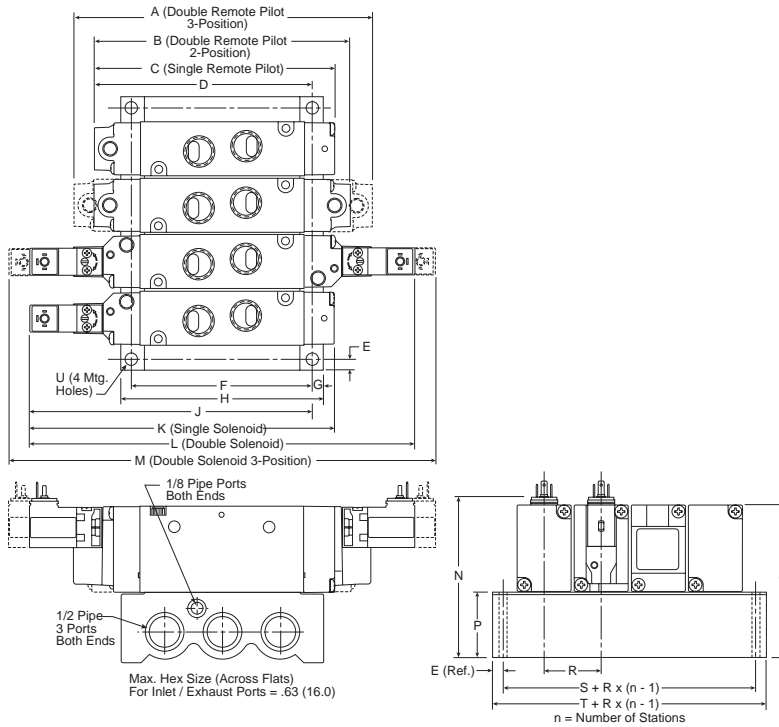

B6 4-way IEM Aluminum Bar Manifold

A	B	C	D	E
6.54 (166.0)	5.59 (142.1)	5.26 (133.7)	4.76 (121.0)	.24 (6.0)
F	G	H	J	K
3.94 (100.0)	.24 (6.0)	4.41 (112.0)	6.17 (156.8)	6.67 (169.5)
L	M	N	P	Q
8.41 (213.7)	9.35 (237.6)	3.60 (91.3)	1.54 (39.0)	3.43 (87.0)
R	S	T	U	
1.24 (31.5)	1.77 (45.0)	2.24 (57.0)	ø .26 ø (6.5)	

Inches (mm)

B6 Single Operators – 3-way IEM Aluminum Bar

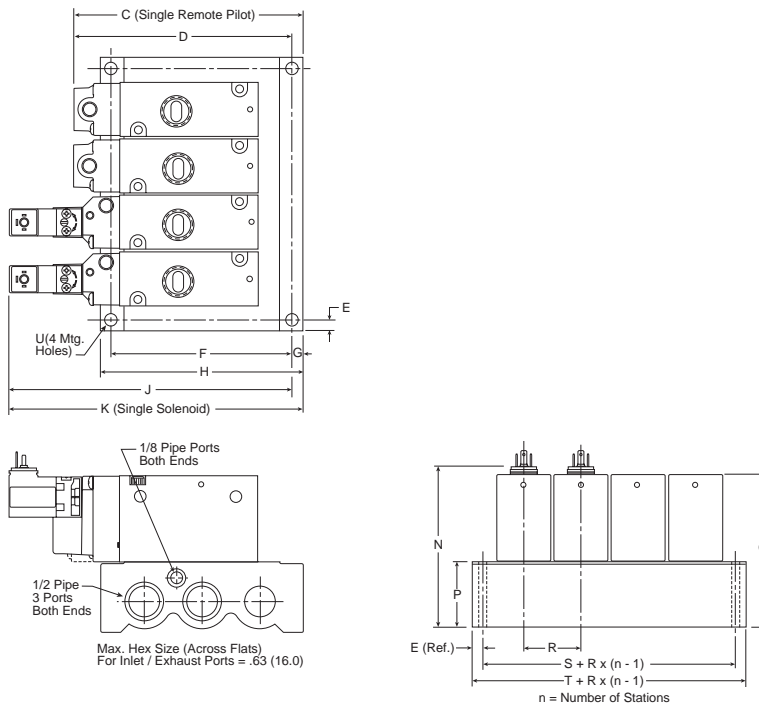

B6 3-way IEM Aluminum Bar Manifold

C	D	E	F	G
5.00 (127.0)	4.76 (121.0)	.24 (6.0)	3.94 (100.0)	.24 (6.0)
H	J	K	N	P
4.41 (112.0)	6.17 (156.8)	6.41 (162.8)	3.60 (91.3)	1.54 (39.0)
Q	R	S	T	U
3.43 (87.0)	1.24 (31.5)	1.77 (45.0)	2.24 (57.0)	Ø .26 Ø (6.5)

Inches (mm)



For inventory, lead times, and kit lookup, visit www.pdnplu.com

C70

Parker Hannifin Corporation
Pneumatic Division
Richland, Michigan
www.parker.com/pneumatics

C
 Inline Valves
 Viking Lite
 Viking Extreme
 "B" Series
 Air Saver Unit
 ADEX Series
 "N" Series

B6 3 & 4-way Alternative Electrical Enclosures

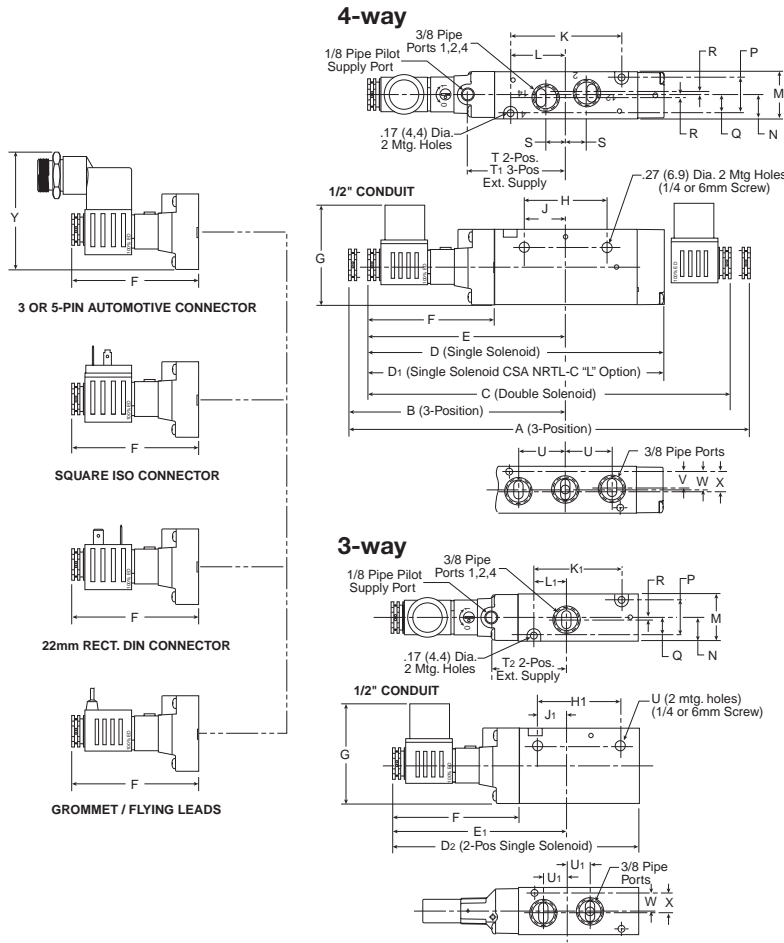

B6 Alternative – Electrical Enclosures

A	B	C	D	D1
10.84 (275.3)	5.41 (137.5)	9.89 (251.3)	7.41 (188.2)	7.74 (196.6)
D2	E	E2	F	G
6.17 (156.6)	4.94 (125.6)	4.37 (111.0)	3.15 (80.0)	2.47 (62.8)
H	H1	J	J1	K
2.09 (53.0)	2.09 (53.0)	1.04 (26.5)	0.76 (19.4)	2.79 (70.8)
K1	L	L1	M	N
2.19 (55.6)	1.39 (35.4)	.82 (20.7)	1.18 (30.0)	.59 (15.0)
P	Q	R	S	T
.91 (23.0)	.45 (11.5)	.06 (1.6)	.51 (13.1)	2.45 (62.3)
T1	T2	U	U1	V
2.93 (29.7)	1.89 (48.0)	.59 (15.0)	.59 (15.0)	.41 (10.5)
W	X	Y		
.45 (11.5)	.49 (12.5)	2.90 (73.6)		

Inches (mm)

B7& B8 Single & Double Operators – 4-way Inline

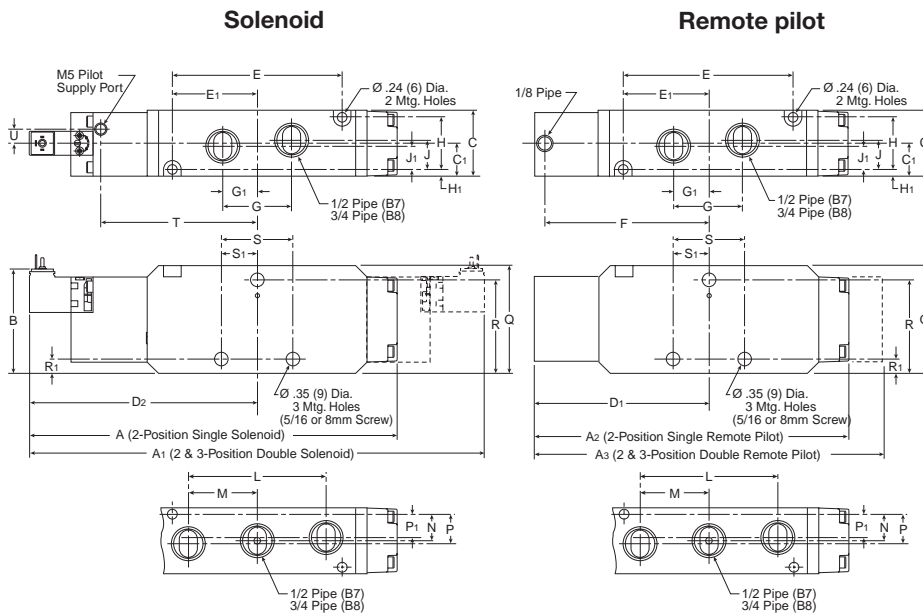

B7 & B8 4-way Inline

A	A1	A2	A3	B
9.13 (232)	11.29 (287)	7.79 (198)	8.62 (219)	2.59 (66)
C	C1	D1	D2	E
1.65 (42)	.83 (21)	4.29 (109)	5.63 (143)	4.21 (107)
E1	F	G	G1	H
2.13 (54)	4.06 (103)	1.73 (44)	.87 (22)	1.29 (33)
H1	J	J1	L	M
.16 (4)	.75 (19)	.59 (15)	3.39 (86)	1.69 (43)
N	P	P1	Q	R
.67 (17)	.75 (19)	.59 (15)	2.68 (68)	2.32 (59)
R1	S	S1	T	U
.35 (9)	1.81 (46)	.90 (23)	3.94 (100)	.35 (9)

Inches (mm)

C

Inline Valves

Viking Lite

Viking Extreme

"B" Series

Air Saver Unit

ADEX Series

"N" Series



For inventory, lead time, and kit lookup, visit www.pdnplu.com

C71

Parker Hannifin Corporation
 Pneumatic Division
 Richland, Michigan
www.parker.com/pneumatics

B7 & B8 Single Operators – 3-way Inline

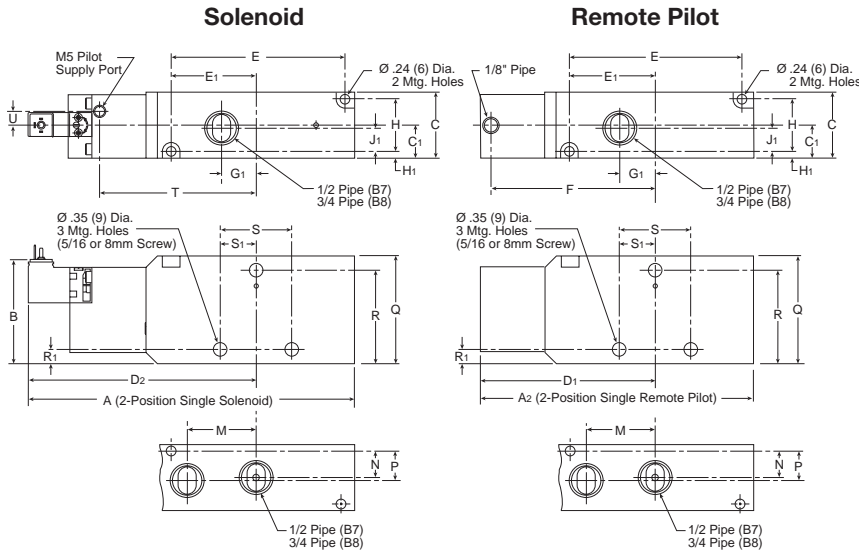

B7 & B8 3-way Inline

A	A₂	B	C	C₁
7.99 (203)	6.65 (169)	2.59 (66)	1.65 (42)	.83 (21)
D₁	D₂	E	E₁	F
4.29 (109)	5.63 (143)	4.21 (107)	2.13 (54)	4.06 (103)
G₁	H	H₁	J₁	M
.86 (22)	1.29 (33)	.16 (4)	.59 (15)	1.69 (43)
N	P	Q	R	R₁
.67 (17)	.75 (19)	2.68 (68)	2.32 (59)	.35 (9)
S	S₁	T	U	
1.81 (46)	.90 (23)	3.94 (100)	.35 (9)	

Inches (mm)

B7 & B8 Single & Double Operators – 4-way IEM Aluminum Bar

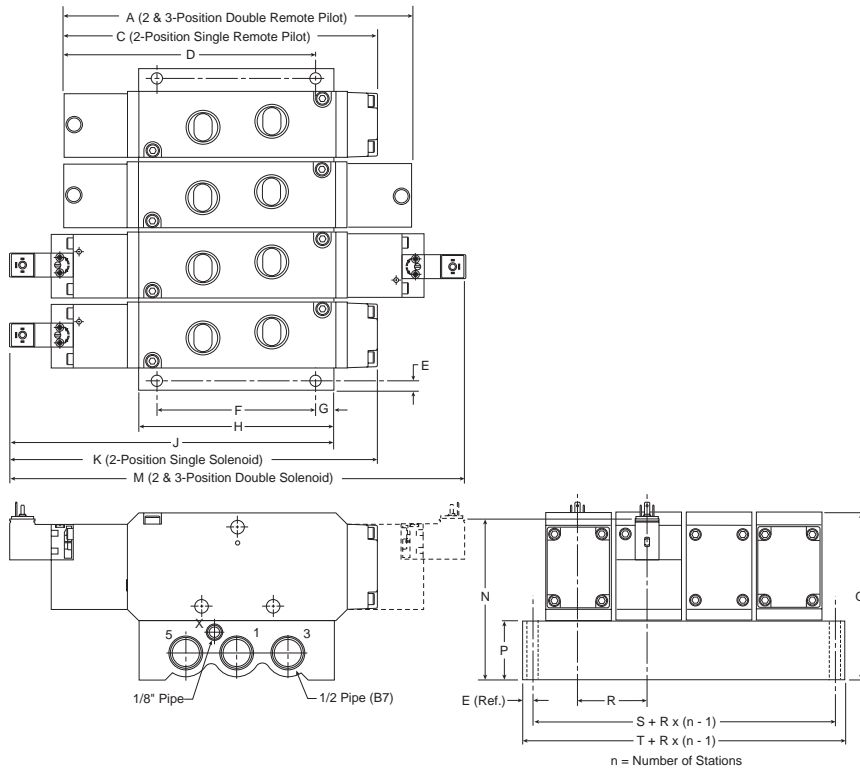

**B7 & B8 4-way IEM
 Aluminum Bar Manifold**

A	C	D	E	F
7.79 (198)	8.62 (219)	6.26 (159)	.24 (6)	3.94 (100)
G	H	J	K	M
.45 (11.5)	4.84 (123)	8.07 (205)	9.13 (232)	11.29 (287)
N	P	Q	R	S
4.00 (101.5)	1.48 (37.5)	4.15 (105.5)	1.77 (45)	2.24 (57)
T				
2.72 (69)				

Inches (mm)

B7 & B8 Single Operators – 3-way IEM Aluminum Bar

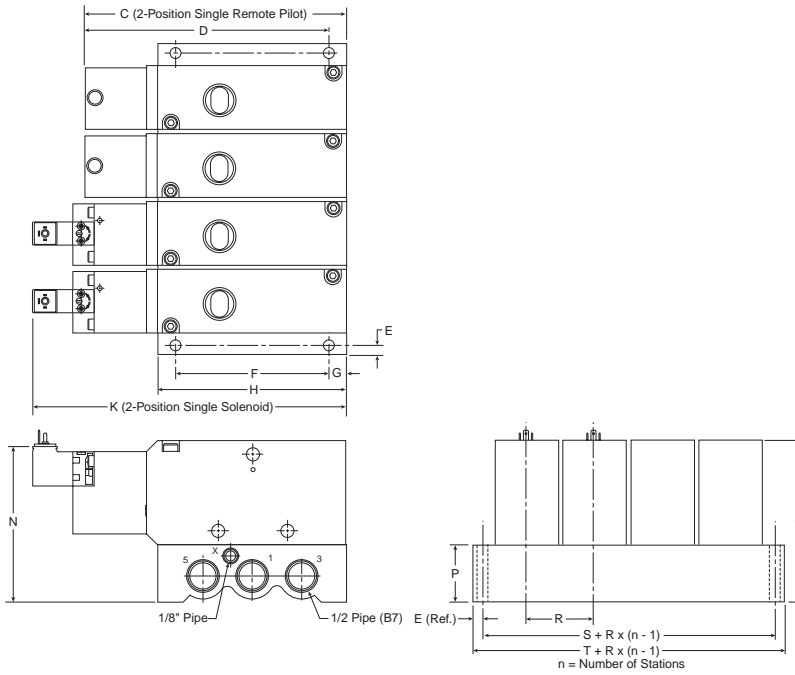

B7 & B8 3-way IEM Aluminum Bar Manifold

C	D	E	F	G
6.65 (169)	4.92 (124.9)	.24 (6)	3.94 (100)	.45 (11.5)
H	K	N	P	Q
4.84 (123)	7.99 (203)	4.00 (101.5)	1.48 (37.5)	4.15 (105.5)
R	S	T		
1.77 (45)	2.24 (57)	2.72 (69)		

Inches (mm)

B7 & B8 3 & 4-way Alternative Electrical Enclosures

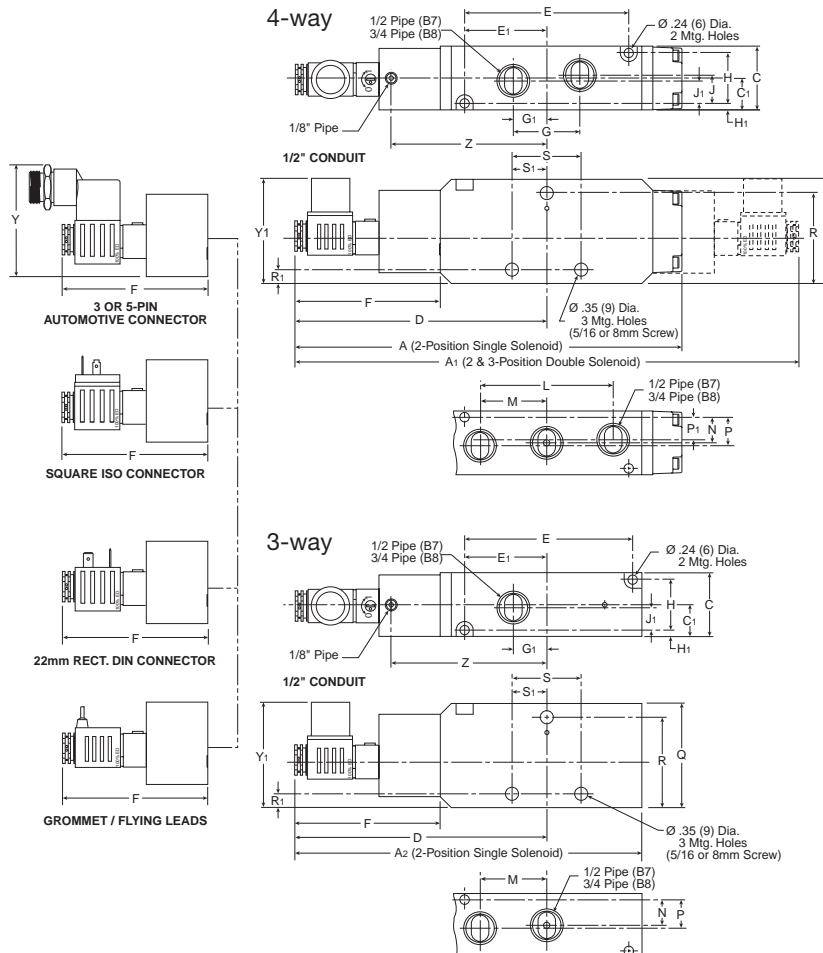

B7 & B8 3 & 4-way Alternative Electrical Enclosures

A	A ₁	A ₂	C	C ₁
9.92 (252)	12.91 (328)	8.78 (223)	1.65 (42)	.83 (21)
D	E	E ₁	F	G
6.46 (164)	4.21 (107)	2.13 (54)	3.74 (95)	1.73 (44)
G ₁	H	H ₁	J	J ₁
.86 (22)	1.29 (33)	.16 (4)	.75 (19)	.59 (15)
L	M	N	P	P ₁
3.39 (86)	1.69 (43)	.67 (17)	.75 (19)	.59 (15)
Q	R	R ₁	S	S ₁
2.68 (68)	2.32 (59)	.35 (9)	1.81 (46)	.90 (23)
Y	Y ₁	Z		
2.87 (73)	2.71 (69)	3.98 (101)		

Inches (mm)



For inventory, lead time, and kit lookup, visit www.pdnplu.com

C73

Parker Hannifin Corporation
 Pneumatic Division
 Richland, Michigan
www.parker.com/pneumatics

C

Inline Valves

Viking Lite

Viking Extreme

"B" Series

Air Saver Unit

ADEX Series

"N" Series

Features

Air Saver Unit

**An easy solution to your environmental protection efforts!
The Air Saver Unit contributes to power savings and CO₂ reduction.**

Parker Air Saver Unit

Up to **50%*** Savings!

Pulsing air technology reduces consumption.

The Air Saver Unit is a valve that converts a continuous air blow to a pulsed air blow without the need for any other external control. Air is blown with a series of ON and OFF pulses. When the blow is OFF, there is no air consumption.

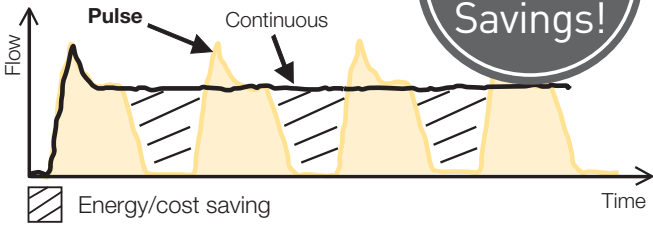

When using an Air Saver Unit several significant benefits can be achieved. Air blowing accounts for almost 50% of all compressed air used in plants. By using switching valve technology the Air Saver Unit can reduce air consumption by up to 50%!

* To achieve the benefits of pulsed air, the Air Saver Unit should be installed no more than 3 meters away from the air blow orifice. For optimal results install within 1 meter.

- Large reductions in air consumption.
- Savings in compressor power consumption.
- Reduction in plant CO₂ emissions.
- Big contribution to energy-saving activities.
- Improved efficiency.

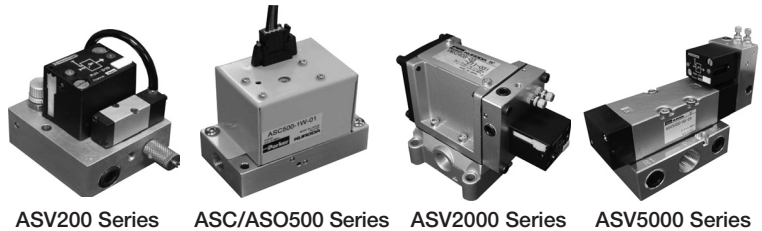

C
Inline Valves
Viking Lite
Viking Extreme
"B" Series
Air Saver Unit
ADEX Series
"N" Series

Try our fast and easy online savings calculator! www.linktovms.com/airsaver

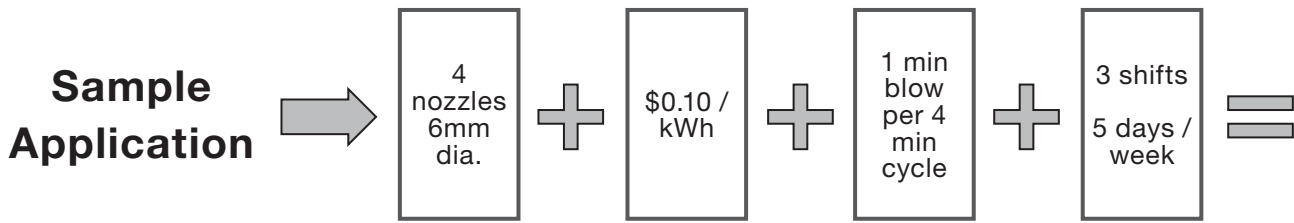

ENGINEERING YOUR SUCCESS.

Prepared for _____ Prepared by _____ **Air Saver Unit Valve Calculator Summary Sheet**

VALUE IMPACT SUMMARY

Reduced Total Annual Air Discharge Per Blowing Nozzle (cfm) by:	3,232,005
Reduced Annual CO ₂ Emissions Generated (Per Blowing Nozzle - in Tons) by:	5.77 tons
Reduced Annual Air Generating Costs Per Blowing Nozzle by:	\$ 892.03
Quantity of Air Blowing Nozzles With Same Application Specifications	4
Reduced Annual Air Generating Costs For All Nozzles by:	\$ 3,568.13
Reduced Annual CO ₂ Emissions Generated (For All Blowing Nozzles) by:	23.07



For inventory, lead times, and kit lookup, visit www.pdnplu.com

Features

Installation is simple and reduction in air consumption can be realized immediately.

- When using an electrically operated solenoid valve to control the air blow, an Air Saver Unit can quickly and easily be retrofitted providing an immediate reduction in air consumption with no changes to the PLC program.

Before introduction of the unit

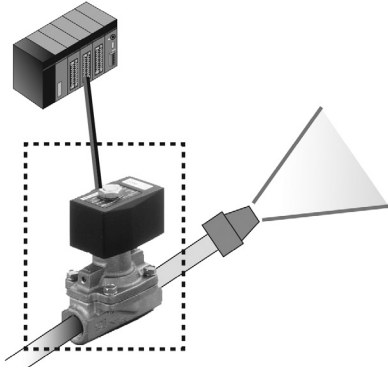

After introduction of the unit

- Easy to install. Change the current solenoid valve to Air Saver Unit. (ASC500 or ASO500)
- Program change of controller is not necessary.

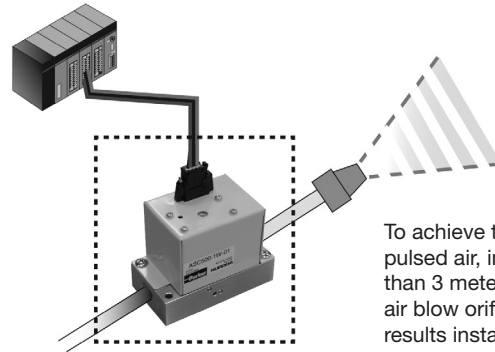

To achieve the benefits of pulsed air, install no more than 3 meters away from the air blow orifice. For optimal results install within 1 meter.

- When using manual valves such as ball valves, simply install either ASV200, ASV500 or ASV2000 units which do not need electrical power. Installing the unit brings immediate reduction in air consumption and improved compressor efficiency.

Before introduction of the unit

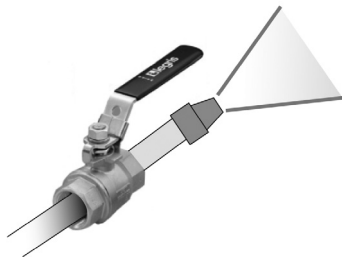

After introduction of the unit

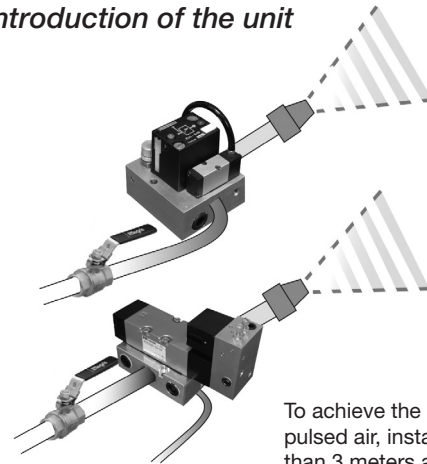

To achieve the benefits of pulsed air, install no more than 3 meters away from the air blow orifice. For optimal results install within 1 meter.

[Company A] Food & Beverage manufacturer

“When we tested ASV5000, we achieved about 55% reduction of our air consumption. Because air blow efficiency was improved, we plan to use more Air Saver Units in other areas in the plant”.

[Company B] Manufacturer of office document machines

“We are working on energy-saving activities. In those activities, we decided to use an Air Saver Unit. We have more than 100 points of air blow and we reduced our air consumption by 42% using this unit”.



C

Inline Valves

Viking Lite

Viking Extreme

“B” Series

Air Saver Unit







ADEX Series

“N” Series



For inventory, lead time, and kit lookup, visit www.pdnplu.com

Specifications

								Unit
Function	Normally closed						Normally open	--
Fluid	Non lubricated air							--
Flow (at 72.5 psi)	5.3	70.6	176.6	459.1	529.7	15.9	15.9	scfm
Adjustable pulse frequency	Up to 5	Up to 5	Up to 5	Up to 1	Up to 1	2-22	2-22	Hz
Port size	M5	3/8"	1/2"	1"	1-1/4"	1/8"	1/8"	NPT (BSPP)
Operating temperature	23 to 122							° F
Pressure range	43.5 - 116	0 - 116				29 - 101.5	29 - 72.5	PSI
Pilot air supply	Internal pilot	43.5 - 116 *				Internal pilot		PSI
Blow	Pulse blow					Pulse/Continuous blow		--
Rated voltage	Electrical power is not necessary					DC 24 V		V
Power consumption	-					1.2 W		W
Grade of Insulation	-					NEMA 1		--
Permissible voltage fluctuation	-					+ or - 10		%
Wiring	-					e-CON standard 4 pole sockets		--
Filtration	Dry w/ 40 µm filtration †							--

Notes:

- * External pilot of 43.5 - 116 is required, to ensure proper operation.
- † For maximum life of the unit we recommend 5 micron, but 40 micron filtration is acceptable and will not void warranty.

To achieve the benefits of pulsed air, the Air Saver Unit should be installed no more than 3 meters away from the air blow orifice. For optimal results install within 1 meter.

C
Inline Valves
 Viking Lite
 Viking Extreme
 "B" Series
 Air Saver Unit
 ADEX Series
 "N" Series



For inventory, lead times, and kit lookup, visit www.pdnplu.com



Ordering Information ASV200-AA-M5

Function	Fluid	Flow @ 72.5 psi	Port size	Operating temperature	Pressure range, psi	Pilot air supply, psi	Blow type	Grease	Part number
Normally closed	Dry air	5.3 scfm	M5	23-122°F (A)	43.5-116	Internal pilot	Pulse	Food grade	ASV200-AA-M5
								Petrolatum (B), (for painting applications) (C), (D)	WPASV200-AA-M5

Dimensions: ASV200-AA-M5

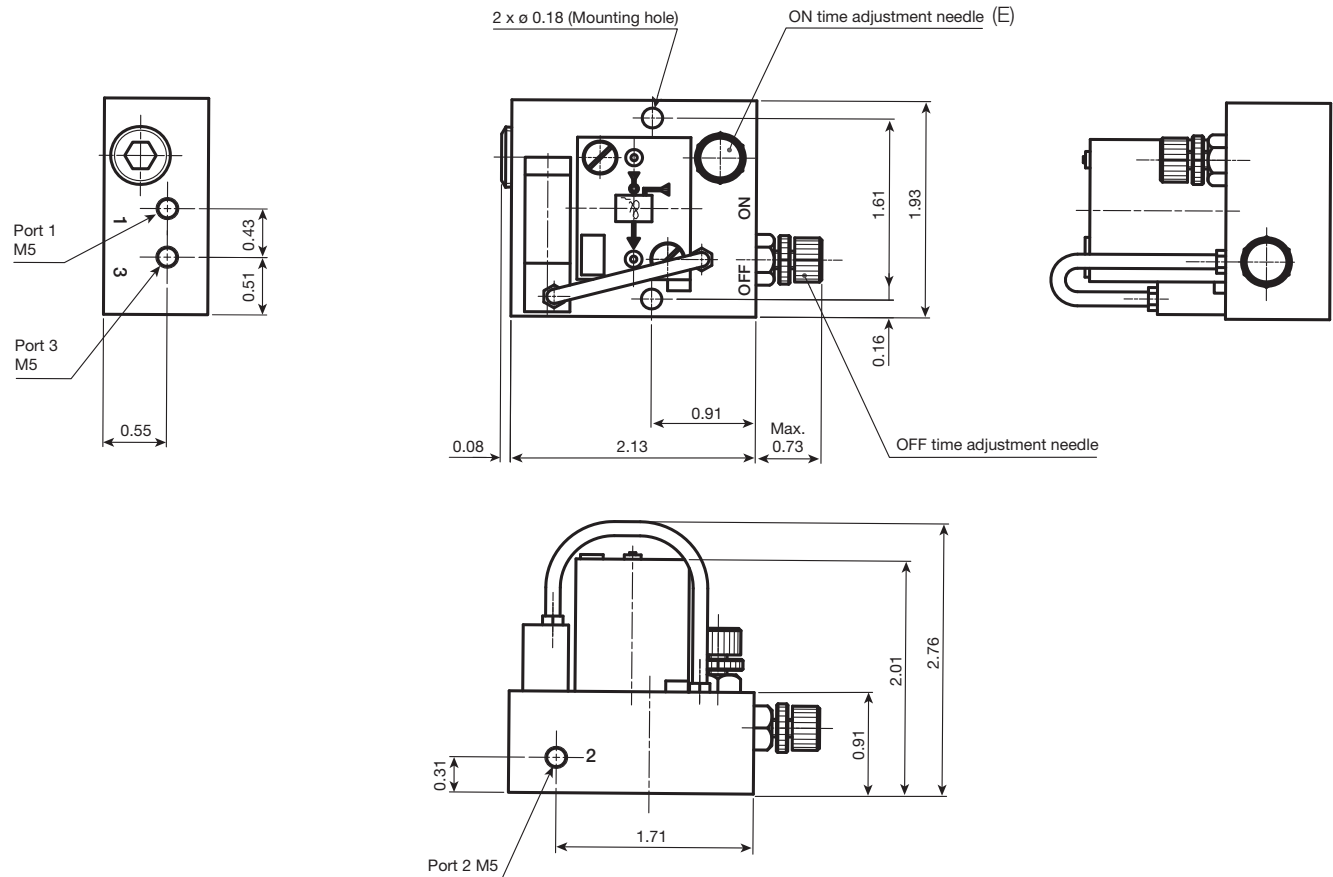

Piping

- Port 1: Supply port (Compressor side)
- Port 2: Output port (Blow nozzle side)
- Port 3: Exhaust port*

* In order to keep out dust, the air muffler is recommended for exhaust port.

Notes:

- A. When temperature of valve goes below 5°C (41°F), complete dry air shall be supplied to prevent from freezing.
- B. Air Saver Units with WP prefix are suitable for most painting applications. Test before use if in direct contact with painted surface.
- C. If test in painting application fails, try cycling Air Saver Unit for 48 hours and repeat test.
- D. DO NOT use "WP" Air Saver Unit in 'clear coat' applications.
- E. Adjustable to maximum frequency of 5Hz.

 Most popular.



For inventory, lead time, and kit lookup, visit www.pdnplu.com

C77

Parker Hannifin Corporation
 Pneumatic Division
 Richland, Michigan
www.parker.com/pneumatics

C

Inline Valves

Viking Lite

Viking Extreme

"B" Series

Air Saver Unit

ADEX Series

"N" Series



Ordering Information ASV2000-AA-xx

Function	Fluid	Flow @ 72.5 psi	Port size	Operating temperature	Pressure range, psi	Pilot air supply, psi	Blow type	Grease	Port type	Part number
Normally closed	Dry air	70.6 scfm	3/8"	23-122°F (A)	0-116	43.5-116	Pulse	Standard	NPT	ASV2000-AA-97
									BSP	ASV2000-AA-17
									NPT (B), (C)	WPASV2000-AA-97
									BSP (D)	WPASV2000-AA-17

Dimensions: ASV2000-AA-97 (NPT model)

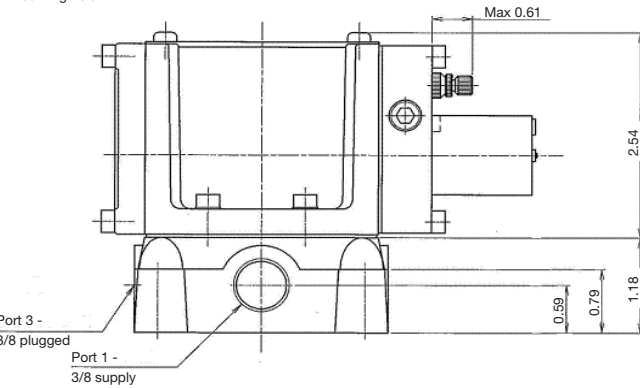
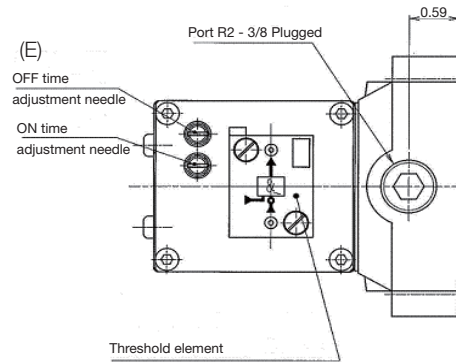
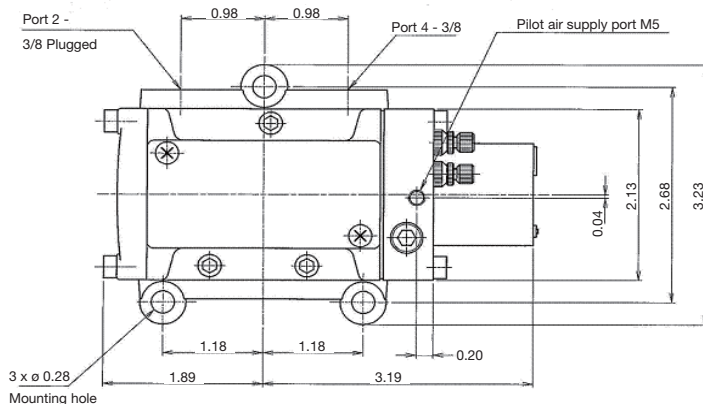

Piping

- Port 1: Supply port (Compressor side)
- Port 2: Plugged
- Port 3: Plugged
- Port 4: Output port (Blow nozzle side)
- Port R2: Plugged
- Port X: M5 pilot air supply >43.5 psi is required

Notes:

- A. When temperature of valve goes below 5°C (41°F), complete dry air shall be supplied to prevent from freezing.
- B. Air Saver Units with WP prefix are suitable for most painting applications. Test before use if in direct contact with painted surface.
- C. If test in painting application fails, try cycling Air Saver Unit for 48 hours and repeat test.
- D. DO NOT use "WP" Air Saver Unit in 'clear coat' applications.
- E. Adjustable to maximum frequency of 5Hz.

Most popular.



For inventory, lead times, and kit lookup, visit www.pdnplu.com



Ordering Information ASV5000-AA-xx

Function	Fluid	Flow @ 72.5 psi	Port size	Operating temperature	Pressure range, psi	Pilot air supply, psi	Blow type	Grease	Port type	Part number
Normally closed	Dry air	176.6 scfm	1/2"	23-122°F (A)	0-116	43.5-116	Pulse	Food grade	NPT	ASV5000-AA-91
									BSPP	ASV5000-AA-21
									NPT	WPASV5000-AA-91
									BSPP	WPASV5000-AA-21

Dimensions: ASV5000-AA-91 (NPT model)

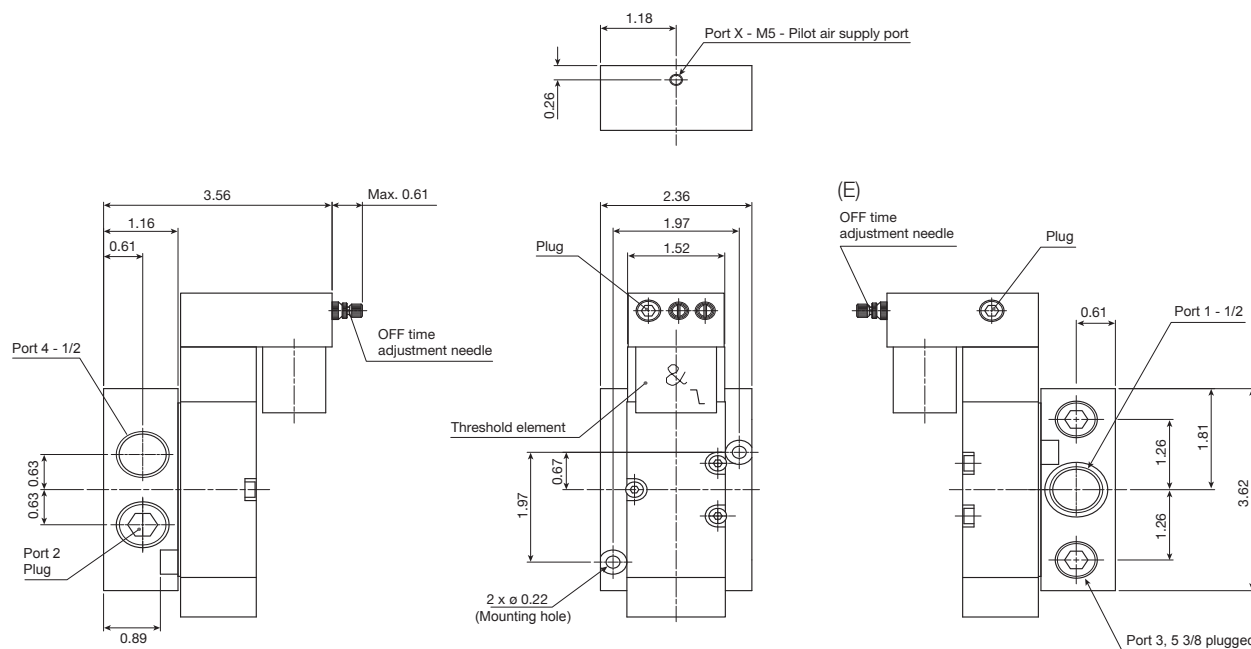

Piping

- Port 1: Supply port (Compressor side)
- Port 2: Plugged
- Port 3: Plugged
- Port 4: Output port (Blow nozzle side)
- Port 5: Plugged
- Port X: M5 pilot air supply >43.5 psi is required

Notes:

- A. When temperature of valve goes below 5°C (41°F), complete dry air shall be supplied to prevent from freezing.
- B. Air Saver Units with WP prefix are suitable for most painting applications. Test before use if in direct contact with painted surface.
- C. If test in painting application fails, try cycling Air Saver Unit for 48 hours and repeat test.
- D. DO NOT use "WP" Air Saver Unit in 'clear coat' applications.
- E. Adjustable to maximum frequency of 5Hz.

Most popular.



For inventory, lead time, and kit lookup, visit www.pdnplu.com

C

Inline Valves

Viking Lite

Viking Extreme

"B" Series

Air Saver Unit

ADEX Series

"N" Series



Ordering Information ASV13000-AA-xx

Function	Fluid	Flow @ 72.5 psi	Port size	Operating temperature	Pressure range, psi	Pilot air supply, psi	Blow type	Grease	Port type	Part number
Normally closed	Dry air	459.1 scfm	1"	23-122°F (A)	0-116	43.5-116	Pulse	Petrolatum (for painting applications)	(B),	WPASV13000-AA-94
									(C),	WPASV13000-AA-34
									(D)	

Dimensions: ASV13000-AA-94 (NPT model)

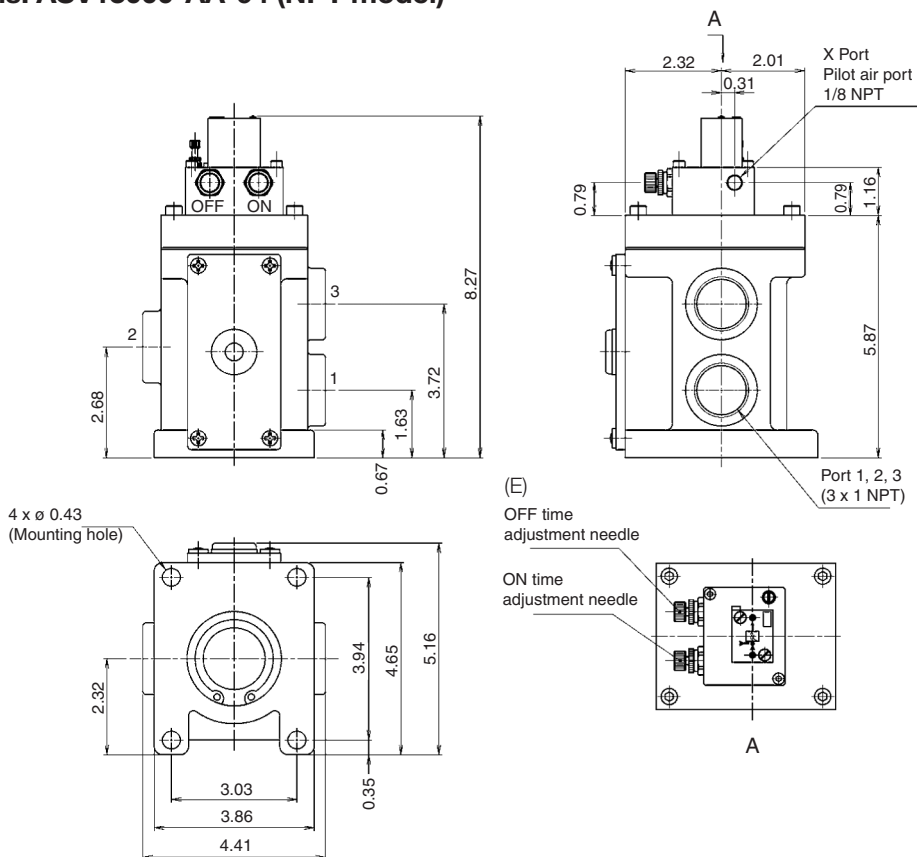

Piping

- Port 1: Supply port (Compressor side)
- Port 2: Output port (Blow nozzle side)
- Port 3: Plugged
- Port X: 1/8 NPT pilot air supply >43.5 psi is required

Notes:

- A. When temperature of valve goes below 5°C (41°F), complete dry air shall be supplied to prevent from freezing.
- B. Air Saver Units with WP prefix are suitable for most painting applications. Test before use if in direct contact with painted surface.
- C. If test in painting application fails, try cycling Air Saver Unit for 48 hours and repeat test.
- D. DO NOT use "WP" Air Saver Unit in 'clear coat' applications
- E. Adjustable to maximum frequency of 1Hz.

Most popular.



For inventory, lead times, and kit lookup, visit www.pdnplu.com

C80

Parker Hannifin Corporation
Pneumatic Division
Richland, Michigan
www.parker.com/pneumatics



Ordering Information ASV15000-AA-xx

Function	Fluid	Flow @ 72.5 psi	Port size	Operating temperature	Pressure range, psi	Pilot air supply, psi	Blow type	Grease	Port type	Part number
Normally closed	Dry air	529.7 scfm	1-1/4"	23-122°F (A)	0-116	43.5-116	Pulse	Petrolatum (B), (for painting applications) (C), (D)	NPT	WPASV15000-AA-92
									BSPP	WPASV15000-AA-42

Dimensions: ASV15000-AA-92 (NPT model)

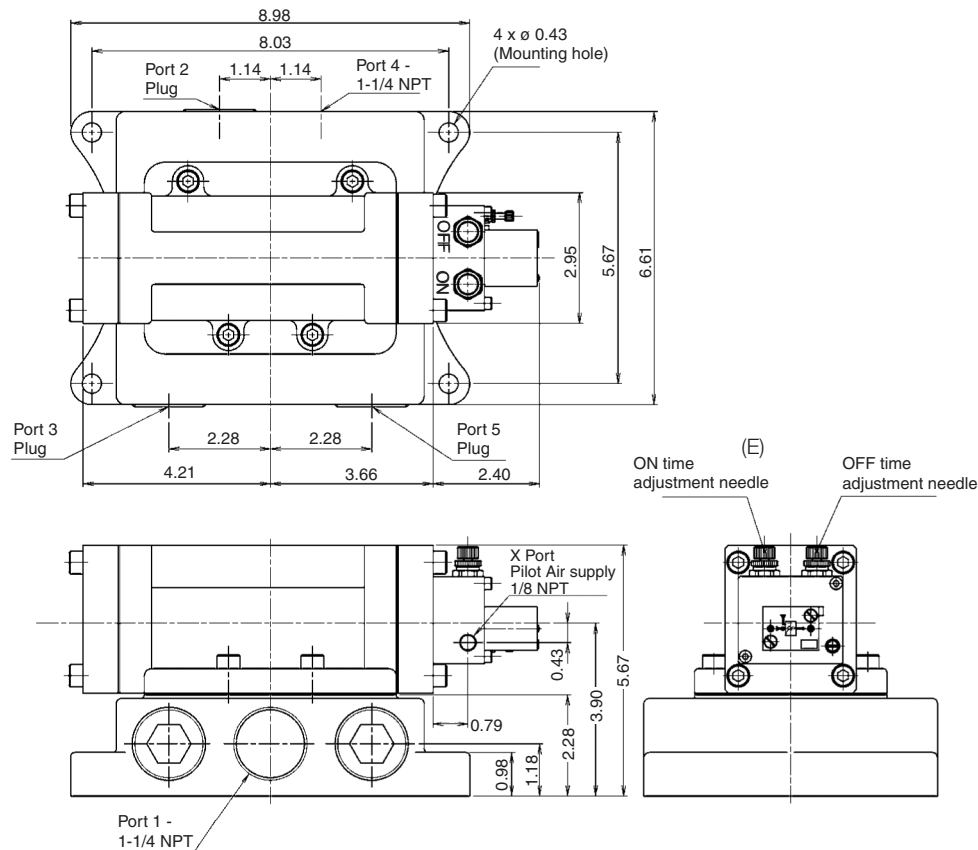

Piping

- Port 1: Supply port (Compressor side)
- Port 2: Plug (1-1/4)
- Port 3: Plug (1-1/4)
- Port 4: Output port (Blow nozzle side)
- Port 5: Plug (1-1/4)
- Port X: 1/8 NPT pilot air supply
>43.5 psi is required

Notes:

- A. When temperature of valve goes below 5°C (41°F), complete dry air shall be supplied to prevent from freezing.
- B. Air Saver Units with WP prefix are suitable for most painting applications. Test before use if in direct contact with painted surface.
- C. If test in painting application fails, try cycling Air Saver Unit for 48 hours and repeat test.
- D. DO NOT use "WP" Air Saver Unit in 'clear coat' applications.
- E. Adjustable to maximum frequency of 1Hz.

Most popular.



For inventory, lead time, and kit lookup, visit www.pdnplu.com



Ordering Information ASC500-1W / ASO500-1W

Function	Fluid	Flow @ 72.5 psi	Port size	Operating temperature	Pressure range, psi	Pilot air supply, psi	Blow type	Port type	Part number
Normally closed	Dry air	15.9 scfm	1/8"	23-122°F	29-72.5	Internal pilot	Pulse/continuous	NPT	ASC500-1W-90
								BSP	ASC500-1W-10
Normally open	Dry air	15.9 scfm	1/8"	23-122°F (A)	29-72.5	Internal pilot	Pulse/continuous	NPT	ASO500-1W-90
								BSP	ASO500-1W-10

Cable

Cable with specific connector (AWG26 ASC/ASO in common)

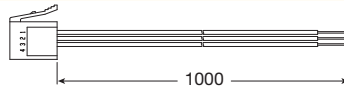

ASC-D24-CL10

Dimensions: ASC500-1W-90 / ASO500-1W-90 (NPT model)

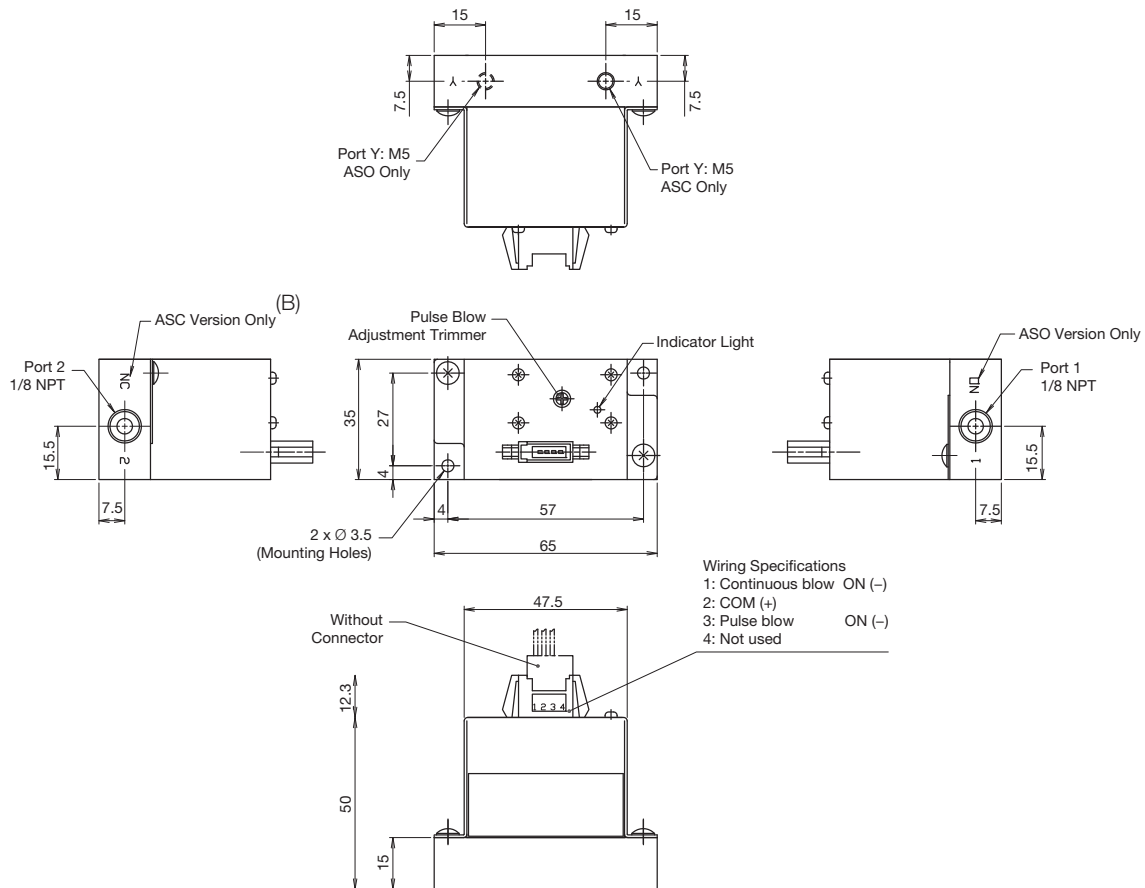

Piping

Port 1: Supply port (Compressor side)
 Port 2: Output port (Blow nozzle side)
 Y port: Pilot exhaust port*

* In order to avoid dust, it is recommended to attach an air muffler.

Notes:

- A. When temperature of valve goes below 5°C (41°F), complete dry air shall be supplied to prevent from freezing.
- B. Adjustable to maximum frequency of 22Hz.

Most popular.



For inventory, lead times, and kit lookup, visit www.pdnplu.com

ADEX Series

ADEX Series are miniature low power consumption solenoid valves, ideal for powering small to mid-sized pneumatic actuators used in automation and process applications. ADEX's versatility is further enhanced through its three mounting styles and electronic connectivity options.

Features

- Compact body size
- Fast response < 10ms

Ports

- A00: M3 – .02 Cv
- A05: M5 – .18 Cv
- A12: 1/8 inch – .47 Cv

Mounting

- Inline
- Subbase mount

Solenoids

- 0.6 W
- 5VDC, 12VDC, 24VDC and 110/220VAC
- LED and surge suppression

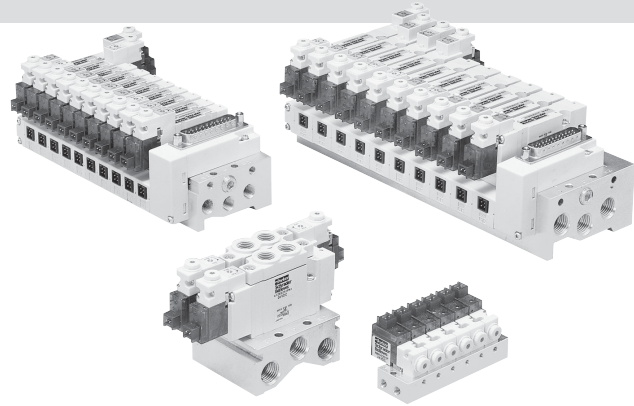

Operating information

Maximum operating pressure*:

A05 & A12	Vacuum to 100 PSIG (Vacuum to 6.8 bar)
A00 (NC)	Vacuum to 100 PSIG (Vacuum to 6.8 bar)
A00 (NO)	Vacuum to 70 PSIG (Vacuum to 4.8 bar)

Minimum operating pressure: See chart below

Operating temperature:

Intermittent Duty (AC & DC Voltage):	32°F to 122°F (0°C to 50°C)
	Voltage Rated +10 / -10%
Continuous Duty (DC Voltage Only):	32°F to 104°F (0°C to 40°C)
	Voltage Rated +0 / -10%

* When using vacuum and pressure simultaneously on ports 1 & 3, normally closed valve, the maximum pressure is 85 PSIG (586 kPa).
When using vacuum and pressure simultaneously on ports 1 & 3, normally open valve, the maximum pressure is 58 PSIG (400 kPa).

Material specifications

Body	Anodized aluminum
End caps	Anodized aluminum
Coils	Thermoplastic
Fasteners	Stainless steel
Spool	Aluminum and nitrile rubber

Minimum operating pressure

Description	Internal pilot		External pilot		
	PSIG	kPa	PSIG	kPa	
4-way	Single Solenoid	22	152	Vacuum	
				36	248
				Vacuum	
4-way	Double Solenoid – 2-position	15	104	Vacuum	
				36	248
				Vacuum	
4-way	Double Solenoid – 3-position	30	207	Vacuum	
				36	248
				Vacuum	
3-way	A00 Series	Vacuum			

* When using vacuum and pressure on ports 1 & 3 – 85 PSIG (586 kPa) NC; 58 PSIG (400 kPa) NO.

C

Inline Valves

Viking Lite

Viking Extreme

"B" Series

Air Saver Unit



ADEX Series

"N" Series

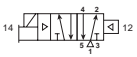
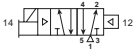
Single Solenoid, 4-way, 2-position

Symbol	Port size	Cv	Voltage	Valve type	Part number
	M5	.17 Cv	24VDC	A05 inline	A05RS251PM5MF
	1/8"	.47 Cv	24VDC	A12 inline	A12RS251PN1MF
	Less base	.18 Cv	24VDC	A06 subbase	A05PS251P
	Less base	.44 Cv	24VDC	A12 subbase	A12PS251P

Double Solenoid, 4-way, 2-position

Symbol	Port size	Cv	Voltage	Valve type	Part number
	M5	.17 Cv	24VDC	A05 inline	A05RD251PM5MF
	1/8"	.47 Cv	24VDC	A12 inline	A12RD251PN1MF
	Less base	.18 Cv	24VDC	A06 subbase	A05PD251P
	Less base	.44 Cv	24VDC	A12 subbase	A12PD251P

Locking flush override. Mounting screws and gaskets included with valve.

A05 / A12 4-way, 2 & 3-position, P / R Types

A05 R S25 - 1 P M5 MF

Basic Series	Valve Type
Series A05	Blank None (Subbase)
Series A12	MF Inline

Body Type	Port Size / Thread Type[†]
Subbase P	Blank None (Subbase)
Inline R	M5 M5 (A05R Only)
	N1 1/8" NPT (A12R Only)
	G1 1/8" BSPP "G" (A12R Only)

[†] Required for inline models only, port size code not used for subbase versions.

Operator / Function	Options
4-Way	P Lights / Surge Suppression
Single Solenoid, 2-Position, Air Return S25	
Double Solenoid, 2-Position D25	
Double Solenoid, 3-Position, APB D35	
Double Solenoid, 3-Position, CE E35	
Double Solenoid, 3-Position, PC O35	

Pilot Source / Exhaust	Voltage
Internal Blank	1 24VDC
External X*	2 12VDC
	9 120/60 VAC

 Most popular.



For inventory, lead times, and kit lookup, visit www.pdnplu.com

Accessories

**Inline Valve Products, ADEX Valve
A05 & A12 Series**

A05 & A12 Subbases

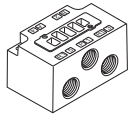

A05PB

Valve type	Port size	Part number
A05	1/8" NPT	A05PBN1
	1/8" BSPP "G"	A05PBG1
A12	1/4" NPT	A12PBN2
	1/4" BSPP "G"	A12PBG2

Kit Includes: (1) Subbase (Hold down bolts and gasket are included with valve)

A05 Valve IEM Bar Manifold



MMFU10A05F Shown

4-way, NPTF (Individual wiring type)	MMFU##A05F
4-way, NPTF (Collective wiring type)	MMCU##A05F

– stations 2 to 20
– stations 2 to 12
(Even numbers only)

Pilot Exhaust for IEM Manifold –
is captured through the "3" and "5" galley.

A12 Valve IEM Bar Manifold



MMFU10A12F Shown

4-way, NPTF (Individual wiring type)	MMFU##A12F
4-way, NPTF (Collective wiring type)	MMCU##A12F

– stations 2 to 20
– stations 2 to 12
(Even numbers only)

Pilot Exhaust for IEM Manifold –
is captured through the "3" and "5" galley.

A05 Valve Subbase Bar Manifold (5-Ported)



4-way, M5 (Individual Wiring Type)	MMFS##A05FM5
4-way, M5 (Collective Wiring Type)	MMCS##A05FM5

– stations 2 to 20
– stations 2 to 12
(Even numbers only)

Internally Piloted Manifolds –
Pilot exhaust is captured through the "3" and "5" galley.

Externally Pilot Manifold –
Pilot exhaust is captured through the "Y" galley.

A12 Valve Subbase Bar Manifold (5-Ported)



4-way, 1/8" NPTF (Individual Wiring Type)	MMFS##A12FF1
4-way, 1/8" NPTF (Collective Wiring Type)	MMCS##A12FF1

– stations 2 to 20
– stations 2 to 12
(Even numbers only)

Internally Piloted Manifolds –
Pilot exhaust is captured through the "3" and "5" galley.

Externally Pilot Manifold –
Pilot exhaust is captured through the "Y" galley.

Most popular.



For inventory, lead time, and kit lookup, visit www.pdnplu.com

Collective Wiring

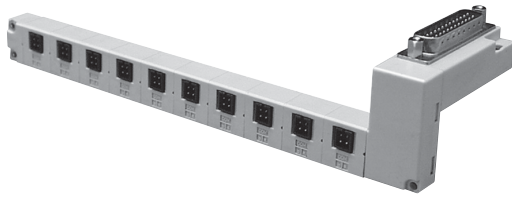

MCS10A05PDL Shown

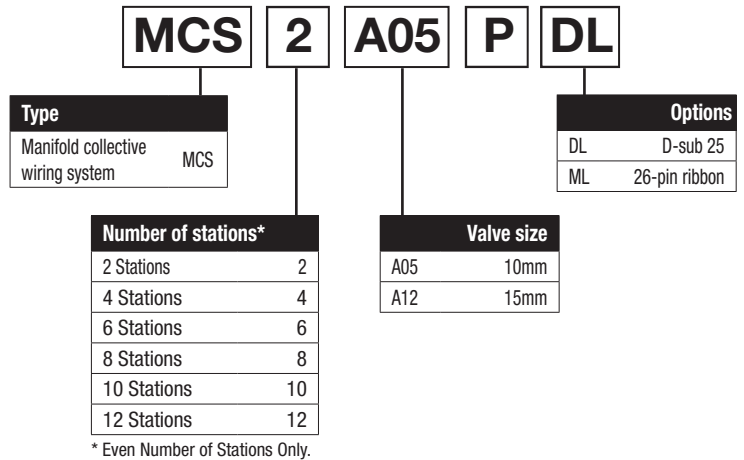

Collective Wiring Pin Mapping
(Not Available for AC Voltages)

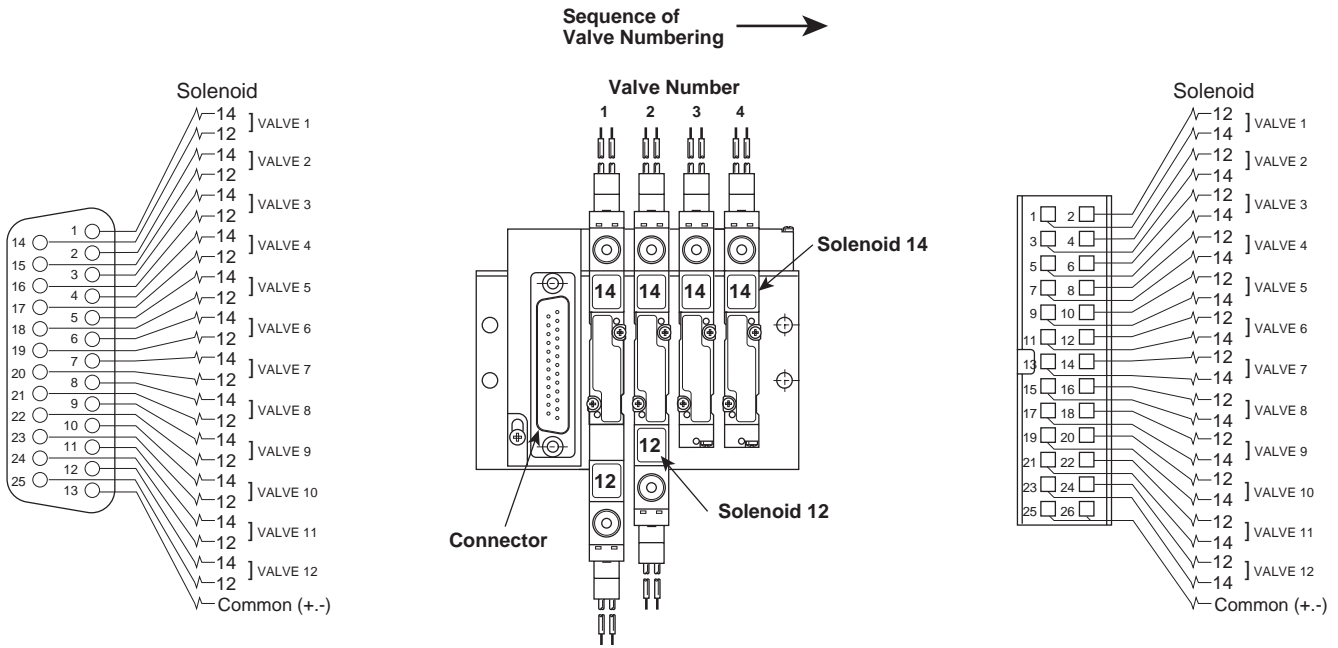

Pin Map for D-Sub 25 Connector

Valve and Solenoid Addresses

Pin Map for 26-Pin Ribbon Connector

Notes:

1. The MCS Collective Wiring System is "Polarity Neutral". Polarity is addressed with the Collective Wired Connectors (page C88). Example: When 'positive' common is used, an A05 single solenoid valve uses an A05PSCC. When 'negative' common is used, use A05PSCCM.
2. The MCS Collective Wiring System provides for both the "14" and "12" addresses at each valve location. When single solenoid valves are used, skip the "12" address for both wiring and controller programming.
3. Be sure that the leakage current of the controller outputs is less than 1.5 ma.



For inventory, lead times, and kit lookup, visit www.pdnplu.com

A00 Valve Only – Single Solenoid, 3-way, 2-position*

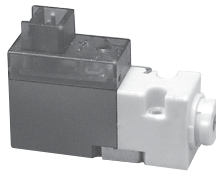

A00SC23-1P Shown

* Screwdriver-Operated, Locking Manual Override (LMOR).

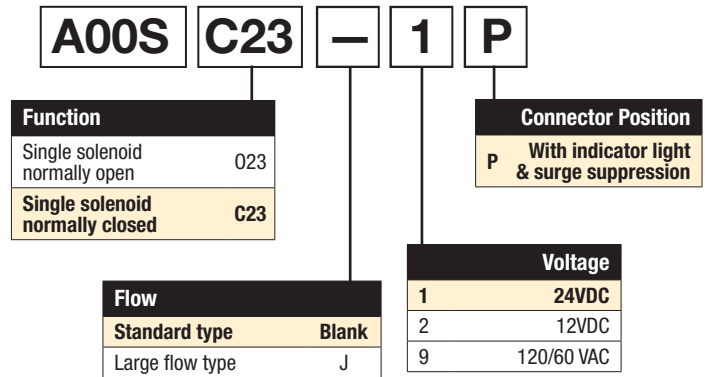

A00 Valve Subbase



Valve type	All Ports	Part number
A00	M3	A00S-B-M3

Mounting screws and gaskets included with valve.

A00 Valve Manifold*



MMFS6A00M5 Shown

* Normally closed valves (A00SC23•P) and Normally open valves (A00S023•P) cannot be mounted on the same manifold simultaneously.
Mounting screws and gaskets included with valve.

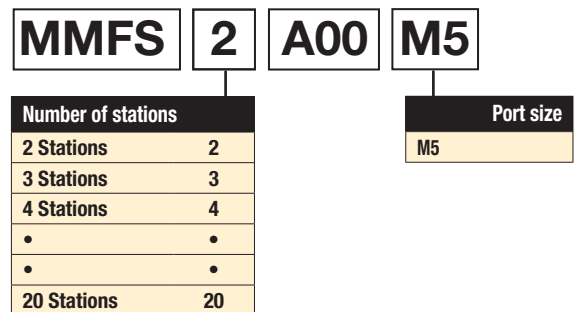

Most popular.



For inventory, lead time, and kit lookup, visit www.pdnplu.com

Accessories

Individual Wired Connectors P / R Type

	Size	Voltage	Length	Part number
	A00	DC	.5 meter	A05P-DC-CL5
			1 meter	A05P-DC-CL10
	A05		3 meter	A05P-DC-CL30
	A12	AC	.5 meter	A05P-AC-CL5
	1 meter		A05P-AC-CL10	

A05PDCCL##

DC Voltage: Positive "+" (Red Wire)
Negative "-" (Black Wire)

AC Voltage: Both Wires are Blue (Polarity Neutral)

Collective Wired Connectors P / R Type

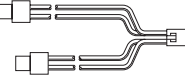
	Size		Part number	
			PNP	NPN
	A05	Single	A05PSCCM	A05PSCC
	A12	Double	A05PDCCM	A05PDCC

A05PDCC

PNP = SOURCING = "Negative Common" = Yellow Wires
NPN = SINKING = "Positive Common" = Red Wires

Wired Connectors with Protective Cover - P / R Type

	Size	Length	Part number
	A00	1 meter	A05P-DC-CB10
	A05		
	A12		

The cover is made of chloroprene rubber for electrical use, assuring excellent weather and insulation resistance. However, be careful not to place it under splash of cutting oil.

Cable with Female D-Sub, 25-Pin Connector

Description	Part number
25-Pin, D-Sub cable, 1 meter (3.3 ft.)	DSS-25W-2K

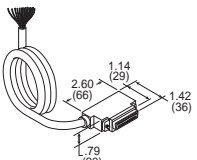

Note: For use with ADEX MCS system only.
Connection to control system is through 25 colored wires AWG 24. Includes (2) M2.5 screws.

Extended Override Cover

Size	Orange: for 14 side solenoid	Green: for 12 side solenoid
	A00	A05P-LA
A05		
A12		

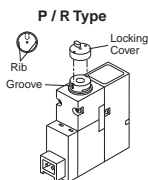

Inline Valve Products, ADEX Valve ADEX Series

Blanking Plate

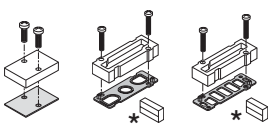
	Size	Type	Part number
	A00	Subbase	A00SBP
	A05	Body ported	A05RGBP
		Subbase	A05PG-BP
A12	Body ported	A12RGBP	
	Subbase	A12PGBP	

A00SBP A05RGBP A05PGBP

* Outlet pin cover used with collective wiring system only.

Individual Air Supply Spacer

Mounts between valve and manifold. Supply from the manifold is blocked and only the valve mounted on the spacer receives the individual supply.

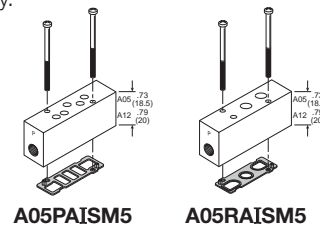

Size	Type	Port size	Internal pilot part number	External pilot* part number
A05	Inline	M5	A05RAISM5	A05RAXISM5
	Subbase	M5	A05PAISM5	A05PAXISM5
A12	Inline	1/8" NPT	A12RAISN1	A12RAXISN1
	Subbase	1/8" NPT	A12PAISN1	A12PAXISN1

Can only be used on Collective wiring type manifolds.

* Can only be used with External Piloted valve. External pilot is located on the X Port of the manifold

Kit Includes: (1) Spacer, (2) Screws, and (1) Gasket

Individual Air Exhaust Spacer

Mounts between valve and manifold. Exhaust from the manifold is blocked and only the valve mounted on the spacer has the individual exhaust.

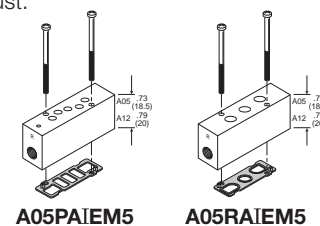

Size	Type	Port size	Internal pilot part number	External pilot* part number
A05	Inline	M5	A05RAIEM5	A05RAXIEM5
	Subbase	M5	A05PAIEM5	A05PAXIEM5
A12	Inline	1/8" NPT	A12RAIEN1	A12RAXIEN1
	Subbase	1/8" NPT	A12PAIEN1	A12PAXIEN1

Can only be used on Collective wiring type manifolds.

* Can only be used with External Piloted valve. External pilot is located on the X Port of the manifold

Kit Includes: (1) Spacer, (2) Screws, and (1) Gasket

C

Inline Valves

Viking Lite

Viking Extreme

"B" Series

Air Saver Unit

ADEX Series

"N" Series



Accessories

DIN Rail Hardware Kit

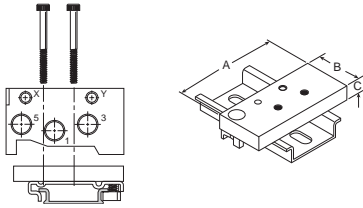

Dimensions

Size	Type	A	B	C	Part number
A05	IEM	2.24	1.00	.31	MFUA05DB
	Subbase	(57)	(25)	(8)	MFSA05DB
A12	IEM	2.91	1.00	.39	MFUA12DB
	Subbase	(74)	(25)	(10)	MFSA12DB

Kit includes: (2) Screws, (2) Clamps



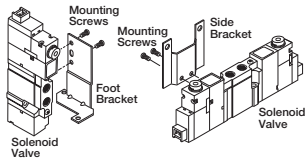

Mounting Bracket



Size	Type	Part number
A05	Side	A05RBS
	Foot	A05RBF
A12	Side	A12-RBS
	Foot	A12RBF

Kit Includes: (1) Bracket, (2) Screws

M3 & M5 Fittings

	Description	Part number
	M5 Plug Fitting	0220 19 00
	M3 to 3mm Barb	BC03M3
	M3 to 4mm Barb	BC04M3
	M5 to 3mm Barb	BC03M5

Labeling Tag

Size	Description	Part number
A05	White Label Tag	A05PN
A12		

**Inline Valve Products, ADEX Valve
ADEX Series**

Exhaust Mufflers



Pipe thread	Part number
M5	P6M-PAC5
1/8" NPT	EM12
1/4" NPT	EM25

P6M - Plastic; EM - Sintered Bronze

Replacement Cylinder Port Plate Kits

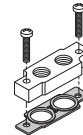

A05RABM5

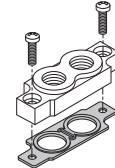

A12RABN1

Size	Fitting	Part number
A05	M5	A05RABM5
A12	1/8" NPT	A12RABN1
	1/8" BSPP "G"	A12RABG1

Replacement Base Gasket Kits

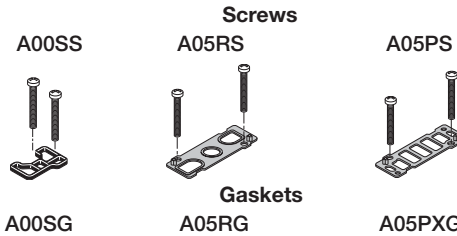

Size	Type	Screws	
		Gasket only	Screw
A00	Subbase	A00SG	A00SS
	Body Ported	A05RG	A05RS
A05	Subbase Int.	A05PG	A05PS
	Subbase Ext.	A05PXG	A05PS
A12	Body Ported	A12RG	A12RS
	Subbase Int.	A12PG	A12PS
	Subbase Ext.	A12PXG	A12PS

These are spare parts, mounting screws and gaskets included with valves.

Flow Rating (Cv)

Size	Port Size	Mounting Style	ANSI / (NFPA)		JIS Method	
			2-Position	3-Position	2-Position	3-Position
A00	M3	Subbase	.010	—	—	—
	M5	Subbase	.017	—	—	—
A00****J	M5	Subbase	.020	—	—	—
A05	M5	Inline	.18	.16	.22	.20
	M5	Subbase	.17	.16	.32	.32
A12	1/8" Ports	Inline	.47	.43	.48	.46
	1/8" Ports	Subbase	.44	.40	.61	.42

ANSI / (NFPA) T3.21.3-1990 standard for Cv measurement.

Response Time

Valve Size	Port Size	0 Cu. In. Test Chamber	
		Fill	Exhaust
2-Position Single Solenoid / Air Return			
A00	M3	.004	.006
A05	M5	.014	.025
A12	1/8"	.016	.030
2-Position Double Solenoid			
A00	M3	—	—
A05	M5	.011	.015
A12	1/8"	.010	.012
3-Position Double Solenoid			
A00	M3	—	—
A05	M5	.013	.017
A12	1/8"	.013	.014

Average Fill Time (Seconds): With 100 PSIG supply, time required to fill from 0-90 PSIG and exhaust from 100 PSIG to 10 PSIG is measured from instant of energizing, or de-energizing 24VDC solenoid. Times shown are average.

Tested per ANSI / (NFPA) T3.21.8.

Solenoid Information

Power Consumption	Standard		
			With Indicator Light & Surge Suppressor
Air Saver Unit	DC	W	0.6
		100V VA	1.2
	AC	110V VA	1.4
ADEX Series	High Flow		
	DC	W	0.91
		100V VA	—
	AC	110V VA	—

ANSI Cv vs. JIS Cv

For Pneumatic Valve flow, the measurement **Cv** – Coefficient of Flow – is used to convey to the user how much air can flow through a given valve. Most valve manufacturers publish this information in their catalogs to assist the user in choosing the proper valve for their application. In publishing this data however, there are discrepancies in how the **Cv** is calculated, resulting in some **Cv**'s being **OVERSTATED** by **20 to 40%**. This can adversely affect the user's application because the valve flows **LESS** than the published **Cv**.

The reason for the large discrepancy is in the method of calculation - the ANSI (NFPA) or the JIS standard.

Parker's **Cv** valve is calculated using the ANSI (NFPA) T3.21.3-1990 standard. The ANSI (NFPA) method is a structured test using very specific tube sizes and lengths, inlet pressures and pressure drops, and volume chambers.

Locking Flush Override. Mounting screws and gaskets included with valve.

C

Inline Valves

Viking Lite

Viking Extreme

"B" Series

Air Saver Unit

ADEX Series

"N" Series



For inventory, lead times, and kit lookup, visit www.pdnplu.com

**Single Solenoid
 3-Way, 2-Position NC**

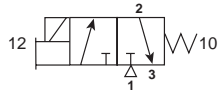

Vacuum Applications (Device becomes NO):
 '1' port is connected to atmosphere or compressed air † when required.
 '2' port is outlet
 '3' port is connected to vacuum
 † When both vacuum and compressed air are required, maximum pressure is 85 PSIG (586 kPa).

**Single Solenoid
 3-Way, 2-Position NO***

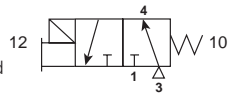

* To obtain NO function, ports 1 & 3 are reversed (1 becomes exhaust and 3 becomes supply).

Vacuum Applications (Device becomes NC):
 '1' port is connected to vacuum
 '2' port is outlet
 '3' port is connected to atmosphere or compressed air † when required.
 † When both vacuum and compressed air are required, maximum pressure is 58 PSIG (400 kPa).

Caution: Normally Open and Normally Closed 3-Way valve cannot be mixed on the same manifold.

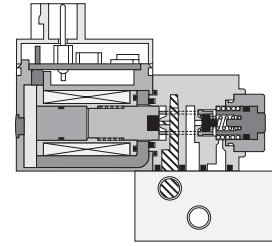

A00S Single Solenoid Normally Closed (NC)

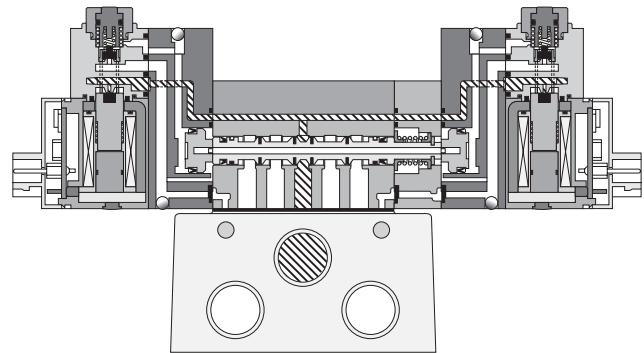

A05P Double Solenoid 3-Position Subbase Mounted

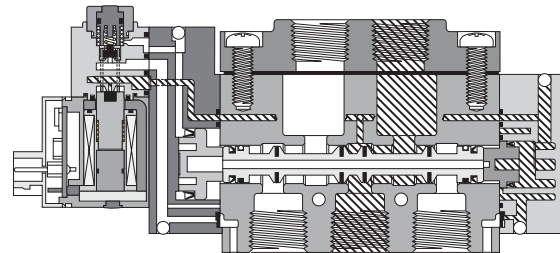

A12R Single Solenoid Inline

Pressure Exhaust

C	Inline Valves
	Viking Lite
	Viking Extreme
	"B" Series
	Air Saver Unit
	ADEX Series
	"N" Series

A00 Subbase

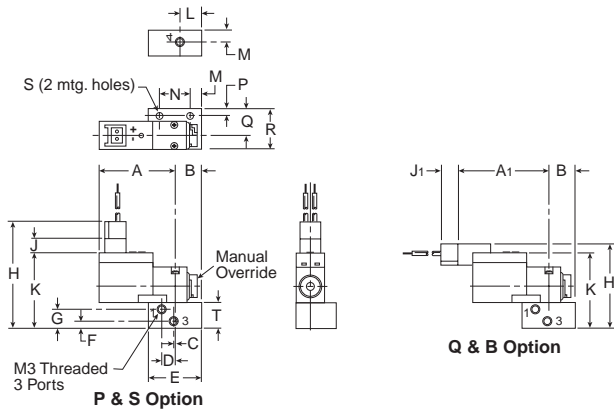

A00 - Subbase

A	A ₁	B	C	D
1.00 (25)	1.18 (30)	.41 (11)	.015 (.4)	.17 (4)
E	F	G	H	H ₁
.79 (20)	.12 (3)	.28 (7)	1.54 (39)	1.38 (34)
J	J ₁	K	L	M
.24 (6)	.20 (5)	1.11 (28)	.32 (8)	.18 (5)
N	P	Q	R	S
.47 (12)	.10 (3)	.39 (10)	.59 (15)	.106 (2.7)
T	.38 (10)			

Inches (mm)

A00 Manifold

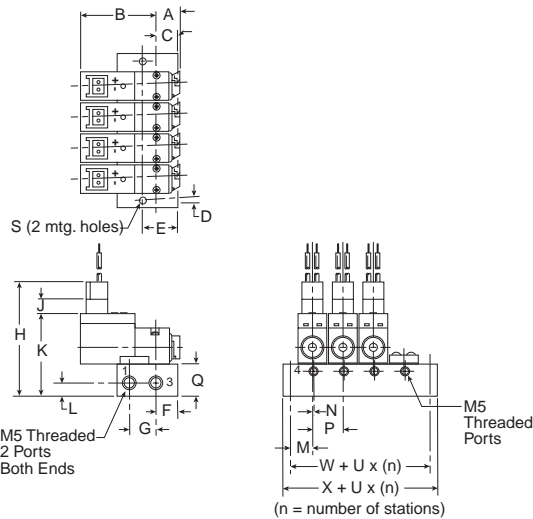

A00 - Manifold

A	B	C	D	E	
.36 (9)	1.00 (25)	.31 (8)	.10 (3)	.51 (13)	
F	G	H	J	K	
.31 (8)	.39 (10)	1.63 (42)	.20 (5)	1.22 (31)	
L	M	N	P	Q	
.20 (5)	.33 (9)	.02 (.6)	.41 (10.5)	.47 (12)	
S	U	X	W		
.125 (3.2)	.41 (10.5)	.45 (11.5)	.26 (6.5)		

Inches (mm)

A05R Single & Double Operators – Inline

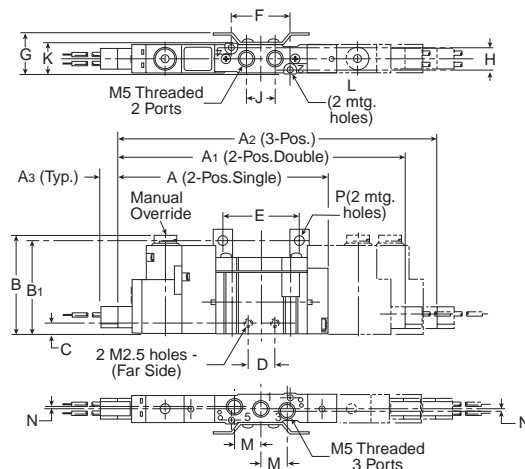

A05R – Inline

A	A ₁	A ₂	A ₃	B
2.91 (74)	3.94 (100)	4.25 (108)	.24 (6)	1.38 (35)
B ₁	C	D	E	F
1.30 (33)	.16 (4)	.38 (10)	1.06 (27)	.83 (21)
G	H	J	K	L
.57 (15)	.33 (9)	.40 (10)	.45 (11.4)	∅ .08 ∅ (2.1)
M	N	P		
.37 (10)	.04 (1)	∅ .14 ∅ (3.5)		

Inches (mm)



For inventory, lead times, and kit lookup, visit www.pdnplu.com

A12R Single & Double Operators – Inline

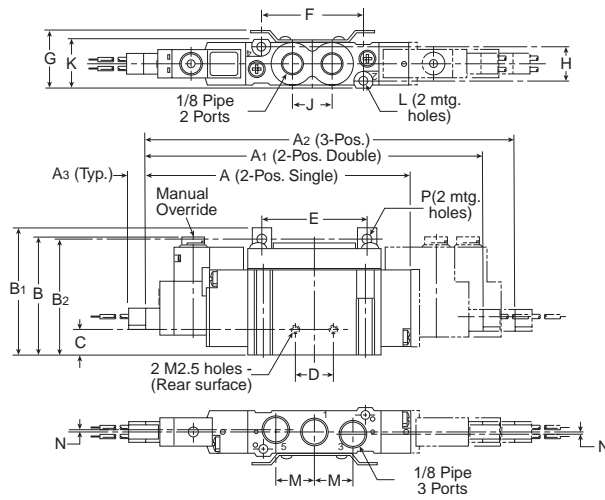

A12R – Inline

A	A1	A2	A3	B
3.68 (94)	4.69 (119)	5.12 (130)	.24 (6)	1.64 (42)
B1	B2	C	D	E
1.77 (45)	1.70 (43)	.35 (9)	.51 (13)	1.46 (37)
F	G	H	J	K
1.42 (36)	.80 (20)	.47 (12)	.55 (14)	.68 (17)
L	M	N	P	
Ø .12 Ø (3.1)	.55 (14)	.03 (0.8)	Ø .14 Ø (3.5)	

Inches (mm)

A05P Single & Double Operators – Subbase

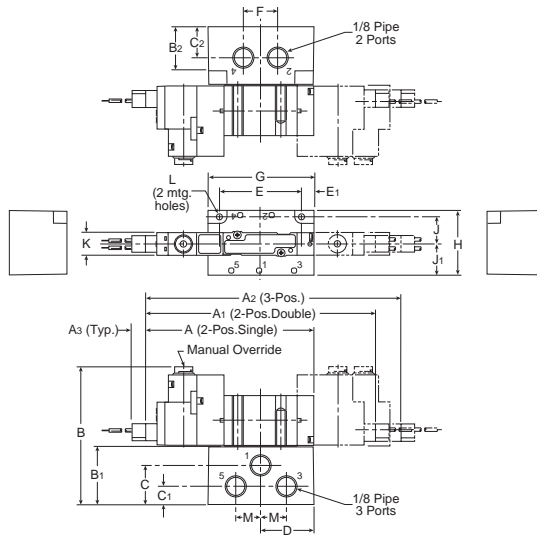

A05P – Subbase

A	A1	A2	A3	B
2.91 (74)	3.94 (100)	4.25 (108)	.24 (6)	2.35 (60)
B1	B2	C	C1	C2
.96 (25)	.75 (19)	.65 (17)	.30 (8)	.53 (14)
D	E	E1	F	G
.89 (23)	1.38 (35)	.20 (5)	.57 (15)	1.77 (45)
H	J	J1	K	L
.08 (28)	.45 (11.5)	.51 (13)	.39 (10)	Ø .13 Ø (3.2)
M				
.45 (12)				

Inches (mm)

A12P Single & Double Operators – Subbase

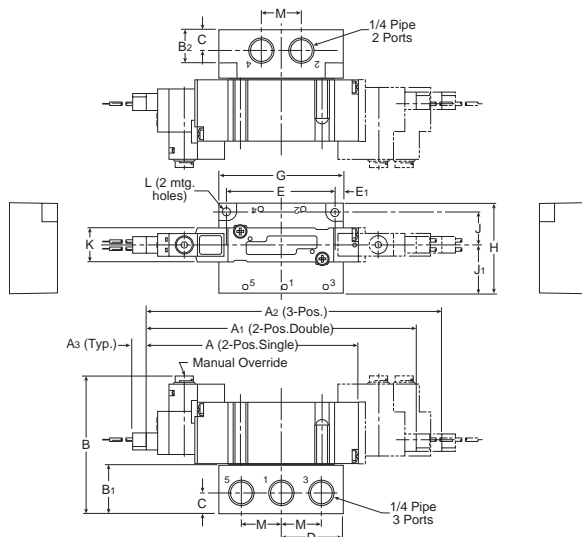

A12P – Subbase

A	A1	A2	A3	B
3.68 (94)	4.69 (119)	5.12 (130)	.24 (6)	2.41 (61)
B1	B2	C	D	E
.87 (22)	.75 (19)	.37 (10)	1.10 (28)	1.89 (48)
E1	G	H	J	J1
.16 (4)	2.20 (56)	1.59 (41)	.57 (14.5)	.87 (22)
K	L	M		
.59 (15)	Ø .17 Ø (4.3)	.71 (18)		

Inches (mm)

C

Inline Valves

Viking Lite

Viking Extreme

"B" Series

Air Saver Unit

ADEX Series

"N" Series



For inventory, lead time, and kit lookup, visit www.pdnplu.com

A05R Manifold – Valve Inline

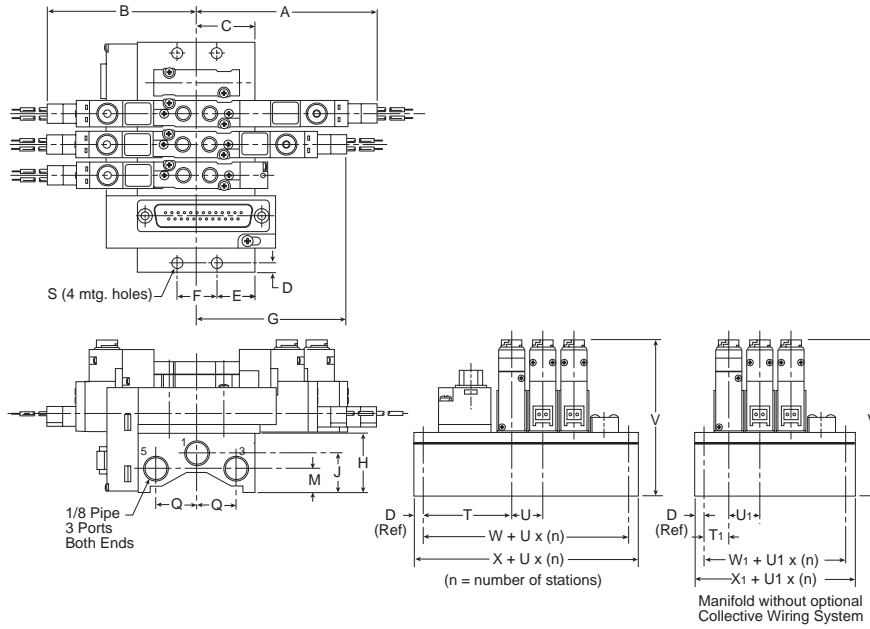

A05R - Manifold, Valve Inline

A	B	C	D	E
2.52 (64)	2.21 (56)	.94 (24)	.16 (4)	.61 (16)
F	G	H	J	M
.63 (16)	2.21 (56)	.94 (24)	.61 (16)	.37 (10)
Q	S	T	T₁	U
.63 (16)	∅ .18 ∅ (4.5)	1.34 (34)	.51 (13)	.49 (12.5)
U₁	V	W	W₁	X
.41 (10.5)	2.32 (59)	1.36 (35)	.37 (9.5)	.167 (43)
X₁				
.68 (17.5)				

Inches (mm)

A12R Manifold – Valve Inline

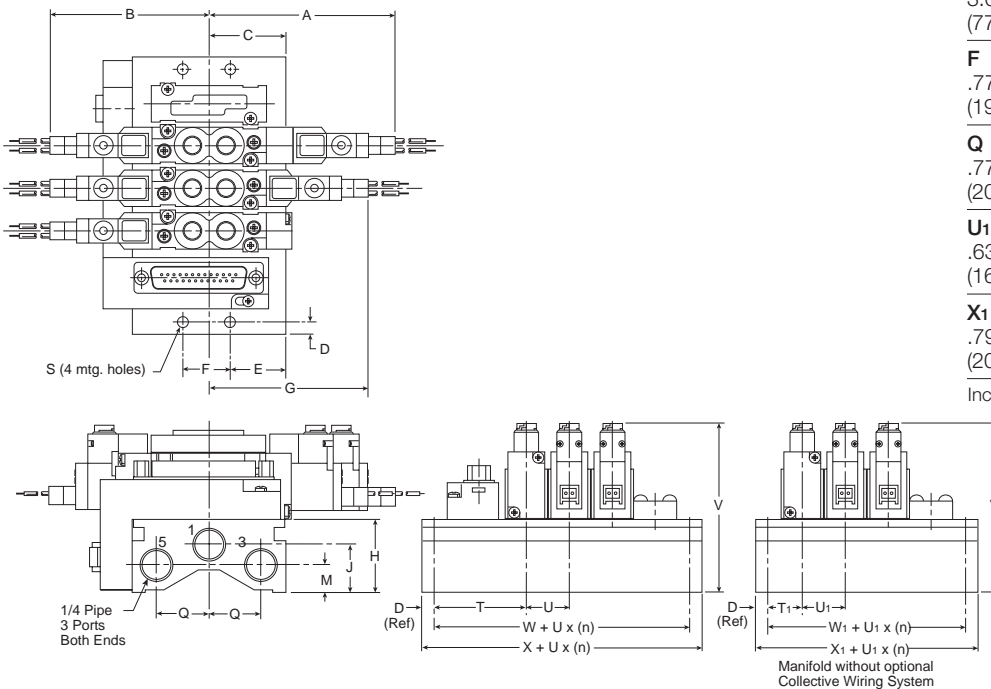

A12R - Manifold, Valve Inline

A	B	C	D	E
3.01 (77)	2.58 (66)	1.14 (29)	.20 (5)	.76 (19)
F	G	H	J	M
.77 (19.6)	2.58 (66)	1.08 (28)	.71 (18)	.41 (11)
Q	S	T	T₁	U
.77 (20)	∅ .18 ∅ (4.5)	1.48 (38)	.51 (13)	.69 (17.5)
U₁	V	W	W₁	X
.63 (16)	2.74 (70)	1.34 (34)	.39 (10)	1.73 (44)
X₁				
.79 (20)				

Inches (mm)

A05P Manifold – Side Ports

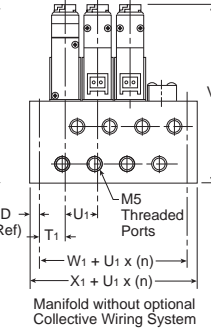
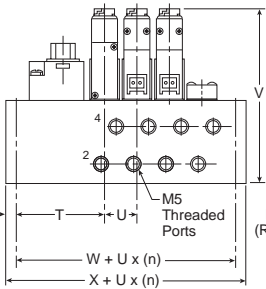
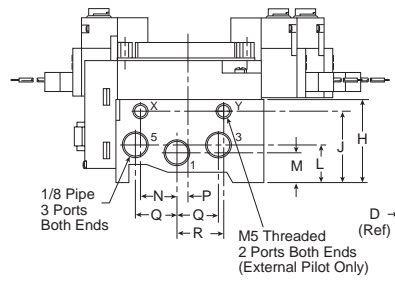
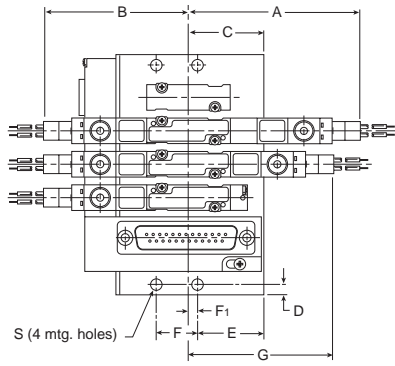

A05P – Manifold, Side Ports

A	B	C	D	E
2.52 (64)	2.21 (56)	1.12 (29)	.16 (4)	1.00 (26)
F	F1	G	H	J
.63 (16)	.19 (5)	2.21 (56)	1.26 (32)	1.08 (28)
L	M	N	P	Q
.59 (15)	.45 (11.5)	.55 (14)	.13 (3)	.63 (16)
R	S	T	T1	U
.71 (18)	∅ .18 ∅ (4.5)	1.34 (34)	.39 (10)	.49 (12.5)
U1	V	W	W1	X
.41 (10.5)	2.64 (67)	1.32 (34)	.37 (10)	1.65 (42)
X1				
.67 (18)				

Inches (mm)

A12P Manifold – Side Ports

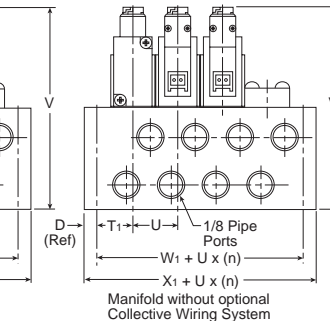
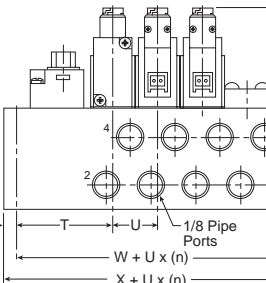
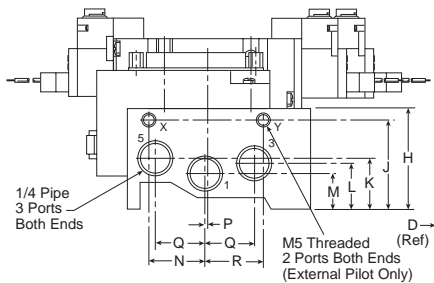
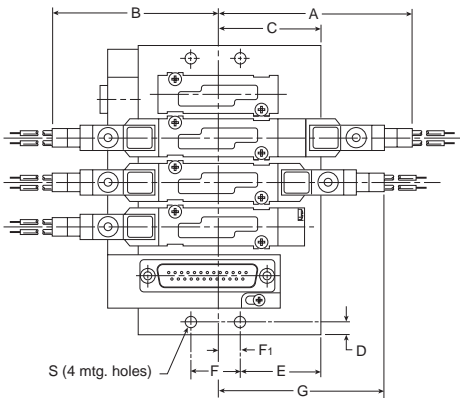

A12P – Manifold, Side Ports

A	B	C	D	E	F
3.01 (77)	2.58 (66)	1.59 (40)	.20 (5)	1.25 (32)	.77 (20)
F	G	H	J	K	L
.34 (9)	2.58 (66)	1.57 (40)	1.38 (35)	.79 (20)	.71 (18)
M	N	P	Q	R	S
.55 (14)	.87 (22)	.04 (1)	.77 (20)	.91 (23)	∅ .18 ∅ (4.5)
T	T1	U	V	W	W1
1.48 (38)	.59 (13)	.69 (17.5)	3.09 (79)	1.34 (34)	.33 (9)
X	X1				
1.73 (44)	.73 (19)				

Inches (mm)

Features

N Series

N Series

For decades Parker Pneumatics and Heavy Industrial have been synonymous with durability and long life. High flow-speed N Series poppet valves have been operating in foundries, steel mills, and automotive casting & stamping plants without fail.

Features

- Continuous duty rated option
- Non-lube service
- Hi-flow, short stroke poppet
- Indicator lights available

Specifications

- 2-way NC
- 3-way NO & NC
- Selector function

Ports

- 3/8" Body – 3/8", 1/2" NPT; 3.0 to 4.4 Cv
- 3/4" Body – 1/2", 3/4", 1" NPT; 9.0 to 11.0 Cv
- 1-1/4" Body – 1", 1-1/4", 1-1/2" NPT; 20.0 to 30.0 Cv
- BSPP "G" threads available

Certification / approval

- Approved to be CE marked (Standard L-Pilot & P-Pilot)
- NEMA 4 Option
- Hazardous Duty Option IP65 Rating / NEMA 4

Material specifications

Valve body	Cast aluminum
Poppet assembly	Aluminum and stainless steel
Pilot Valve	Zinc, stainless steel, brass, copper, zinc plated steel
Seals	Nitrile

Lubrication

The high speed poppet valves are pre-lubricated to permit use with non-lubricated air. However, air should be lubricated to assure maximum seal life.

F442 lubricating oil is recommended. This oil is specially formulated to provide peak performance and maximum service life from air-operated equipment.

Installation

CAUTION: DO NOT RESTRICT THE INLET TO POPPET VALVES

Restriction of the inlet can starve the air supply to the pilot section of internally piloted poppet valves and result in slow shifting or failure of the valve to shift properly. Always connect the supply line directly to the inlet of the valve using the full pipe size of the valve inlet. Never use a quick coupling to connect a poppet valve to the air supply. On valves with a small inlet port, use of an upstream surge tank may be required at lower operating pressures to insure an adequate air supply and proper operation.

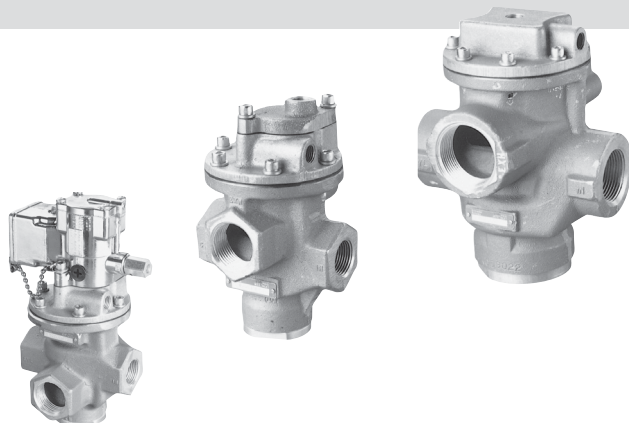

Operating information

Operating pressure:

Solenoid valves - internal pilot supply

3/8" Basic	3/4" Basic	1-1/4" Basic
20 to 140 PSIG (standard)	25 to 140 PSIG (200 PSIG option available)	25 to 140 PSIG (200 PSIG option available)

Solenoid valves - external pilot supply

Air pressure thru valve (PSI)	External pilot pressure required (PSI)*	
	3/8" Basic	3/4" Basic
25 PSI	35-200	35-200
50 PSI	45-200	40-200
75 PSI	55-200	50-200
100 PSI	65-200	65-200

Vacuum up to 1" HG, less than a perfect vacuum.

* With 200 PSI option. Do not exceed 140 PSI with standard pilots.

Internal pilot - remote pilot valve

Air pressure thru valve (PSI)	Remote pilot pressure (PSI)		
	3/8" Basic	3/4" Basic	1-1/4" Basic
25 PSI	30-250	30-250	30-250
50 PSI	50-250	50-250	50-250
75 PSI	70-250	75-250	70-250
100 PSI	95-250	95-250	90-250
150 PSI	140-250	145-250	130-250
200 PSI	175-250	185-250	175-250
250 PSI	215-250	230-250	205-250

Operating temperature:

Operator type	Duty cycle*	Minimum ambient temperature	Maximum ambient temperature
Standard service	Intermittent	0°F (-18°C)	125°F (52°C)
Solenoid	Continuous	0°F (-18°C)	100°F (38°C)
Special service	Intermittent	0°F (-18°C)	125°F (52°C)
Solenoid	Continuous	0°F (-18°C)	125°F (52°C)
Remote pilot	Not applicable	0°F (-18°C)	200°F (93°C)

* Applications with pilot valves energized for ten (10) minutes or longer with a duty cycle greater than 70% are considered to be continuously energized.

$$\text{Duty cycle} = \frac{\text{Time energized}}{\text{Time energized} + \text{time off}} \times 100\% = \% \text{ Duty Cycle}$$

C

Inline Valves

Viking Lite

Viking Extreme

"B" Series

Air Saver Unit

ADEX Series

"N" Series



For inventory, lead times, and kit lookup, visit www.pdnplu.com

Single Solenoid, Non-locking manual override, internal "L" pilot 140 PSI, standard service, junction box w/ light.

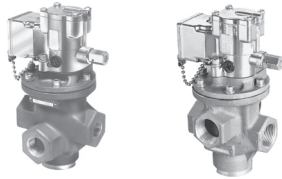

Body size	Cv	In / cyl ports	Exhaust port	Voltage	2-way, 2-position normally closed	3-way, 2-position normally closed	3-way, 2-position normally open
3/8"	3.6 to 3.9	3/8"	1/2"	120VAC	N3153904553	N3553904553	N3753904553
				24VDC	N3153904549	N3553904549	N3753904549
		1/2"	1/2"	120VAC	N3154904553	N3554904553	N3754904553
				24VDC	N3154904549	N3554904549	N3754904549
3/4"	7.7 to 9.6	1/2"	3/4"	120VAC	N3155904553	N3555904553	N3755904553
				24VDC	N3155904549	N3555904549	N3755904549
		3/4"	1"	120VAC	N3156904553	N3556904553	N3756904553
				24VDC	N3156904549	N3556904549	N3756904549
		1"	1"	120VAC	N3157904553	N3557904553	N3757904553
				24VDC	N3157904549	N3557904549	N3757904549

Normally Closed Normally Open

Single Solenoid, Non-locking manual override, internal "L" pilot 140 PSI, standard service, junction box w/ light, 4-pin M12.

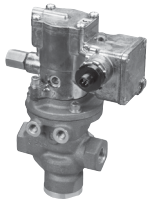

Normally Closed

Body size	Cv	In / cyl ports	Exhaust port	Voltage	2-way, 2-position normally closed	3-way, 2-position normally closed	3-way, 2-position normally open
3/8"	3.6 to 3.9	3/8"	1/2"	24VDC	N3153J04549F	N3553J04549F	N3753J04549F
				24VDC	N3154J04549F	N3554J04549F	N3754J04549F
3/4"	7.7 to 9.6	1/2"	3/4"	24VDC	N3155J04549F	N3555J04549F	N3755J04549F
				24VDC	N3156J04549F	N3556J04549F	N3756J04549F
		3/4"	1"	24VDC	N3156J04549F	N3556J04549F	N3756J04549F
				24VDC	N3157J04549F	N3557J04549F	N3757J04549F

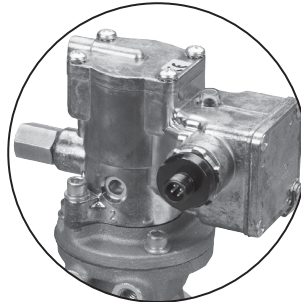

4-Pin Male/Single Solenoid
(Encl. Option J, Wiring Option F)
(Per ISO 202/01)

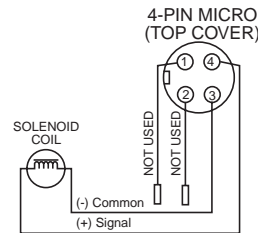

C

Inline Valves

Viking Lite

Viking Extreme

"B" Series

Air Saver Unit

ADEX Series

"N" Series

Most popular.



For inventory, lead time, and kit lookup, visit www.pdnplu.com

Ordering Information

"N" Series 3/8", 3/4" & 1-1/4" Body Sizes - Solenoid 'L' Pilot

N **315** **3** **9** **0** **45** **53**

Valve function - solenoid	
3/8" & 3/4" Body	
2-way, normally closed	315
3-way, normally closed	355
3-way, normally open	375
1-1/4" Body	
2-way, normally closed	325
3-way, normally closed	365
3-way, normally open	385

"L" pilot configuration	
Blank	None
C	Chrysler wiring - enclosure 'J' & 'N'
F	Ford wiring - enclosure 'E', 'J' & 'N'
G	GM wiring - enclosure 'J' & 'N'

Port size / thread type	
3/8" body size	
3/8" inlet & cyl - 1/2" exhaust - NPT	3
1/2" inlet & cyl - 1/2" exhaust - NPT	4
1/2" inlet & cyl - 1/2" exhaust - BSPP	N
3/4" body size	
1/2" inlet & cyl - 3/4" exhaust - NPT	5
3/4" inlet & cyl - 1" exhaust - NPT	6
3/4" inlet & cyl - 1" exhaust - BSPP	Q
1" inlet & cyl - 1" exhaust - NPT	7
1-1/4" body size	
1" inlet & cyl - 1 1/4" exhaust - NPT	7
1-1/4" inlet & cyl - 1-1/2" exhaust - NPT	8
1-1/4" inlet & cyl - 1-1/2" exhaust - BSPP	S*
1-1/2" inlet & cyl - 1-1/2" exhaust - NPT	9
1-1/2" inlet & cyl - 1-1/2" exhaust - BSPP	T*

"L" pilot code						
Code	Voltage			Solenoid enclosure options		
	AC 60hz	AC 50hz	DC	Standard duty (01, 45)	Cont. duty (04, 48)	200 PSI (46)
42	24	24	6	5, 6	6	
45			12	1, 5, 6		
49			24	1, 2, 3, 5, 6, 8, 9, W	6, 8, 9	9
51			48	1		
53	120	110		1, 2, 3, 5, 6, 8, 9, E, N, W	1, 6, 8, 9, N	8, 9, E
57	240	220		1, 3, W		
61			120	5, 6		
79			24	E, J	E, J	E, J

"L" pilot configuration	
01*	External pilot, std service, 140 PSI
04*	External pilot, cont duty, 140 PSI
45	Internal pilot, std service, 140 PSI
46	Internal pilot, std service, 200 PSI
48	Internal pilot, cont duty, 140 PSI

* Not available with valve function 325, 365, and 385 (1-1/4" body).

* Not available with valve function 325.

Note: BSPP is to the ISO 228 standard, and requires an R-BSPT male fitting.

Solenoid enclosure / override	
Basic pilot	1
Basic pilot NLMO	2
Basic pilot LMO	3
Junction box NLMO	5
Junction box LMO	6
Junction box NLMO w/ light	8
Junction box LMO w/ light	9
Basic pilot ext. LMO	W
JIC NLMO w/ light - 3-pin Automotive	E
JIC NLMO w/ light - 4-pin M12	J
JIC NLMO w/ light - 5-pin Automotive	N

Solenoid type	
0	Standard
5*	Hazardous duty
8*	NEMA 4 solenoid

* Available with enclosure 2 & 3, 'L', pilot configuration 04 & 48, and voltage 49 & 53 ONLY.

C
 Inline Valves
 Viking Lite
 Viking Extreme
 "B" Series
 Air Saver Unit
 ADEX Series
 "N" Series

Continuous Duty Pilots

Continuous duty pilots are designed for applications where cycling is infrequent and the pilot is to be energized for indefinite periods of time . . . hours, days or weeks. Typical uses include fail-safe or emergency shutdown circuits where the pilot is to be energized and the valve open as long as the main control is "live" in order to shut off air to equipment in the event of power failure.

The Continuous duty pilot operates satisfactorily in ambient temperatures up to 125°F, even when continuously energized and without the benefit of the cooling air which normally flows through the pilot during frequent cycling. Under certain conditions,

satisfactory operation may be obtained at ambient temperatures above 125°F. CONSULT FACTORY.

Incorporating the performance-proven design features of the standard L-Pilot, the continuous duty pilot utilizes a bullet-shaped stem on the upper end of the plunger. This bullet-shaped stem, seating in a high-temperature rubber o-ring, provides both a bubble-tight seal and positive release.

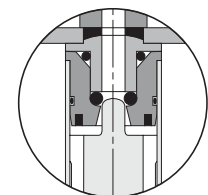

Continuous Duty Pilot

 Most popular.



For inventory, lead times, and kit lookup, visit www.pdnplu.com

Ordering Information

Single Solenoid, Non-locking manual override, internal "P" pilot 125 PSI, standard service, P-pilot junction box w/ light.

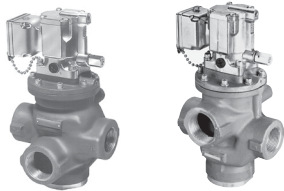

Normally Closed Normally Open

Body size	Cv	In / cyl ports	Exhaust port	Voltage	2-way, 2-position normally closed	3-way, 2-position normally closed	3-way, 2-position normally open
1-1/4"	19.5 to 26.7	1"	1-1/4"	120VAC	N3257904753	N3657904753	N3857904753
		1-1/4"	1-1/2"	120VAC	N3258904753	N3658904753	N3858904753
		1-1/2"	1-1/2"	120VAC	N3259904753	N3659904753	N3859904753

"N" Series 1-1/4" Body Sizes - Solenoid Hi-Flow 'P' Pilot

N 365 8 9 0 47 53

Valve function - solenoid	
1-1/4" body	
2-Way, normally closed	325
3-Way, normally closed	365
3-Way, normally open	385

Port size / thread type	
1-1/4" body size	
1" inlet & cyl - 1 1/4" exhaust - NPT	7
1-1/4" inlet & cyl - 1-1/2" exhaust - NPT	8
1-1/4" inlet & cyl - 1-1/2" exhaust - BSPP	S
1-1/2" inlet & cyl - 1-1/2" exhaust - NPT	9
1-1/2" inlet & cyl - 1-1/2" exhaust - BSPP	T

Note: BSPP is to the ISO 228 standard, and requires an R-BSPT male fitting.

				"P" pilot code	
				Enclosure options	
Code	Voltage			Standard duty	
	AC 60hz	AC 50hz	DC		
49			24	5, 6	
53	120	110		5, 6, 8, 9	

"P" pilot configuration	
02	External pilot, std service, 125 PSI
47	Internal pilot, std service, 125 PSI

Solenoid type	
0	Standard

Solenoid enclosure / override	
5	Junction box NLMO
6	Junction box LMO
8	Junction box NLMO w/ light
9	Junction box LMO w/ light

Most popular.



For inventory, lead time, and kit lookup, visit www.pdnplu.com

C	Inline Valves
	Viking Lite
	Viking Extreme
	"B" Series
	Air Saver Unit
	ADEX Series
	"N" Series

Ordering Information

Single Remote Pilot, 1/4" NPT remote pilot port with internal pilot return.

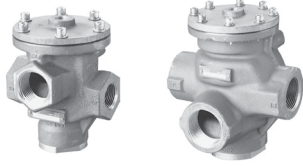

Normally Closed Normally Open

Body size	Cv	In / cyl ports	Exhaust port	2-way, 2-position normally closed	3-way, 2-position normally closed	3-way, 2-position normally open
3/8"	3.6 to 3.9	3/8"	1/2"	N31431091	N35431091	N37431091
		1/2"	1/2"	N31441091	N35441091	N37441091
3/4"	7.7 to 9.6	1/2"	3/4"	N31451091	N35451091	N37451091
		3/4"	1"	N31461091	N35461091	N37461091
		1"	1"	N31471091	N35471091	N37471091

Single Remote Pilot, 1/4" NPT remote pilot port with internal pilot return.

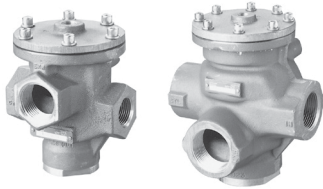

Normally Closed Normally Open

Body size	Cv	In / cyl ports	Exhaust port	2-way, 2-position normally closed	3-way, 2-position normally closed	3-way, 2-position normally open
1-1/4"	19.5 to 26.7	1"	1-1/4"	N32471091	N36471091	N38471091
		1-1/4"	1-1/2"	N32481091	N36481091	N38481091
		1-1/2"	1-1/2"	N32491091	N36491091	N38491091

"N" Series 3/8", 3/4" & 1-1/4" Body Sizes - Remote Pilot

N 314 3 1 091

Valve Function - Solenoid	Port Size / Thread Type	Pilot Configuration
3/8" & 3/4" Body	3/8" Body Size	089 External Pilot Return
2-Way, Normally Closed 314	3/8" Inlet & Cyl - 1/2" Exhaust - NPT 3	091 Internal Pilot Return
3-Way, Normally Closed 354	1/2" Inlet & Cyl - 1/2" Exhaust - NPT 4	
3-Way, Normally Open 374	1/2" Inlet & Cyl - 1/2" Exhaust - BSPP N	
1-1/4" Body	3/4" Body Size	
2-Way, Normally Closed 324	1/2" Inlet & Cyl - 3/4" Exhaust - NPT 5	
3-Way, Normally Closed 364	1/2" Inlet & Cyl - 3/4" Exhaust - BSPP P	
3-Way, Normally Open 384	3/4" Inlet & Cyl - 1" Exhaust - NPT 6	
	3/4" Inlet & Cyl - 1" Exhaust - BSPP Q	
	1" Inlet & Cyl - 1" Exhaust - NPT 7	
	1-1/4" Body Size	
	1" Inlet & Cyl - 1 1/4" Exhaust - NPT 7	
	1-1/4" Inlet & Cyl - 1-1/2" Exhaust - NPT 8	
	1-1/4" Inlet & Cyl - 1-1/2" Exhaust - BSPP S*	
	1-1/2" Inlet & Cyl - 1-1/2" Exhaust - NPT 9	
	1-1/2" Inlet & Cyl - 1-1/2" Exhaust - BSPP T*	

* Not available with Valve Function 325.
Note: BSPP is to the ISO 228 Standard, and requires an R-BSPT male fitting.

Most popular.



For inventory, lead times, and kit lookup, visit www.pdnplu.com

C
Inline Valves
Viking Lite
Viking Extreme
"B" Series
Air Saver Unit
ADEX Series
"N" Series

Replacement Pilots

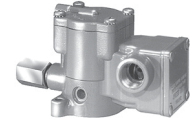

Description	Standard L-pilot		Continuous duty L-pilot	
	Locking	Non-locking	Locking	Non-locking
Override type	Locking	Non-locking	Locking	Non-locking
Basic with override	K0653035**	K0652035**	K0853025**	K0852025**
JIC with junction box & override	K0656035**	K0655035**	K0856025**	K0855025**
JIC pilot with junction box & override & indicator lights (120VAC only)	K0659035**	K0658035**	K0859025**	K0858025**

** Voltage code - (reference model index for availability)

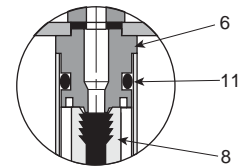
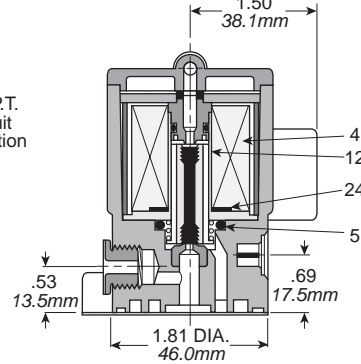
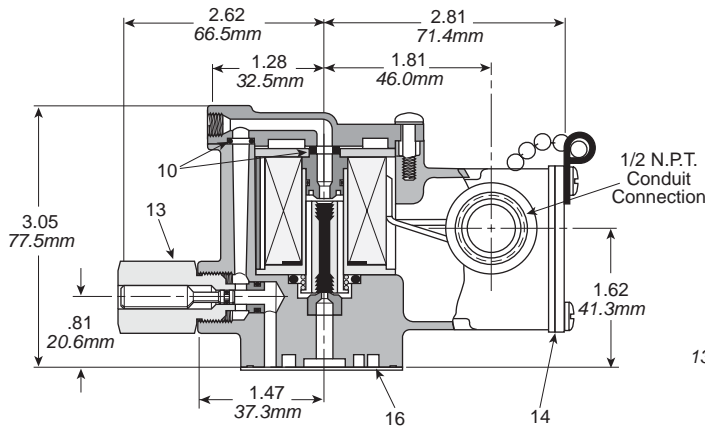

Standard Duty Pilot Only

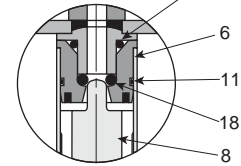

Continuous Duty Pilot Only

Parts List

Item no.	Part number	Description
4	K593025	Coil 120V 60Hz / 110V 50Hz
	K593035	Coil 240V 60Hz / 220V 50Hz
	K593003	Coil 6VDC / 24V 60Hz
	K593010	Coil 12VDC
	K593014	Coil 24VDC
	K593041	Coil 120VDC
5	H14213	Seal
6	K423006	Top Seat
	K423010	Top Seat (Continuous Duty)
8	K343002	Plunger (STD. Service)
	K343001	Plunger (Continuous Duty)
10*	H14201	Seal
11*	K41RB72011	O-Ring (STD. Service)
	H24969	O-Ring (Continuous Duty)

Item no.	Part number	Description
12	K272004	Plunger Guide
13	K152003	Override Assembly
14	K183047	Cover Gasket
16*	K183001	Gasket
18*	H13473	O-Ring
20*	H13413	O-Ring
22	H19102	120 AC Only - Indicator Light
24	K183108	Gasket

Coil leads are 19" long.

* Parts included in Service Kit.

Continuous Duty Kit K352366

Standard Service Kit K352166

C

Inline Valves

Viking Lite

Viking Extreme

"B" Series

Air Saver Unit

ADEX Series

"N" Series



For inventory, lead time, and kit lookup, visit www.pdnplu.com

Replacement Pilots

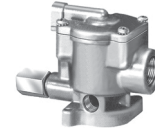
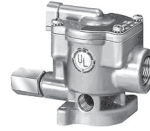

Description	Hazardous duty L-pilot		NEMA 4 L-pilot	
	Hazardous duty L-pilot - UL & CSA	K0451025**	N/A	
Override type	Locking	Non-Locking	Locking	Non-Locking
Hazardous duty with override	K0453025**	K0452025**		
NEMA 4 with override			K2553025**	K255202549

** Voltage code - 49 & 53

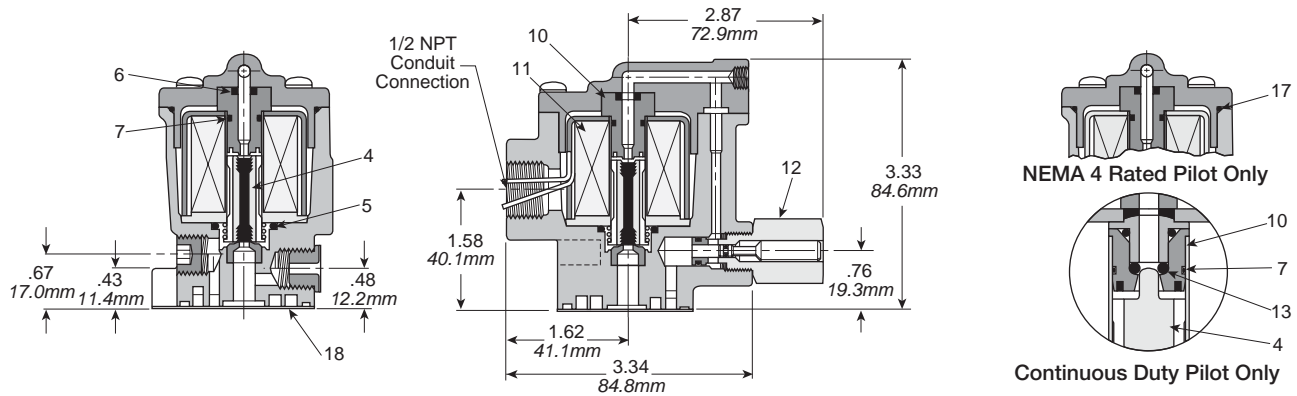

Parts List

Item no.	Part number	Description	Item no.	Part number	Description
4*	K343002	Plunger (STD. Service)	12	K152003	Override Assembly
	K343001	Plunger (Continuous Duty)	13*	H13473	O-Ring
5*	K14213	Seal	17*	H13716	Gasket (NEMA 4 Rated Pilot Only)
6*	K41RB72009	O-Ring	18*	K183001	Gasket
	K41RB72008	O-Ring (STD. Service)			
7*	K41RB72011	O-Ring (STD. Service)			
	H24969	O-Ring (Continuous Duty)			
10	K423001	Top Seat			
	K423002	Top Seat (Continuous Duty)			
	K593025	Coil 120V 60Hz / 110V 50Hz			
	K593035	Coil 240V 60Hz / 220V 50Hz			
	K593003	Coil 6VDC / 24V 60Hz			
11	K593010	Coil 12VDC			
	K593014	Coil 24VDC			
	K593041	Coil 120VDC			

Coil leads are 19" long.
 * Parts included in Service Kit.
 Continuous Duty Kit **K352366**
 Standard Service Kit **K352166**

C
 Inline Valves
 Viking Lite
 Viking Extreme
 "B" Series
 Air Saver Unit
 ADEX Series
 "N" Series



For inventory, lead times, and kit lookup, visit www.pdnplu.com

Replacement Pilots

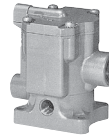

Description	Heavy duty P-Pilot		
	No override	Non-locking	Locking
Override type			
Basic with override	K1351045**	N/A	N/A
JIC with junction box & override	N/A	K1355045**	K1356045**
JIC Pilot with junction box & override & indicator lights (120VAC only)	N/A	K135804553	K135904553

** Voltage code - 49 & 53

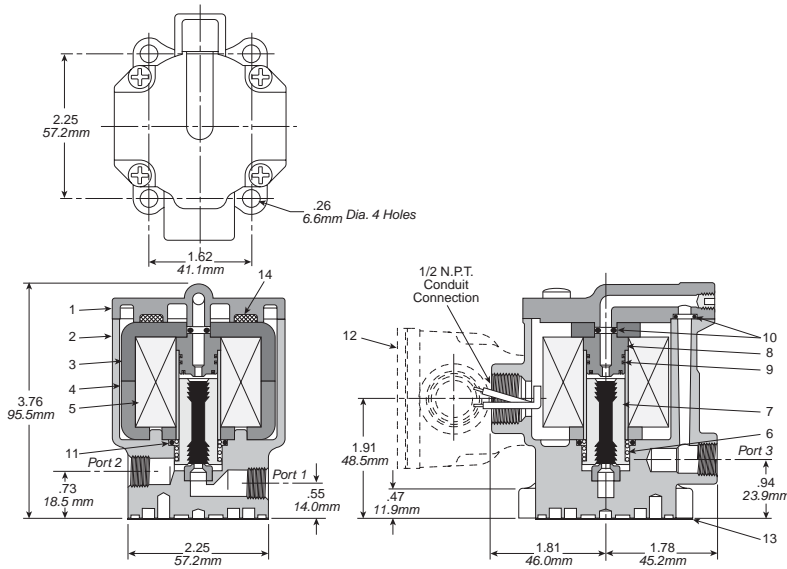

Parts List

Item no.	Part number	Description
1	K062005	Cover Assy
2	K112045	Body, Man. Mtd. (1/8" Bottom Seal)
	K112046	Body, Man. Mtd. (3/16" Bottom Seal)
3	K013001	Magnet Bar
4	K272002	Sleeve Sub Assy
5*	K593108	Coil (115V 60Hz)
	K593112	Coil (230V 60Hz)
	K593097	Coil 24VDC
	K593107	Coil 115VDC

Item no.	Part number	Description
6	K473010	Spring N.O. Valve
	K473011	Spring N.C. Valve
7 •	K343042	Plunger
8	K423020	Top Seat (1/8" Orifice)
	K423022	Top Seat (3/16" Orifice)
9 •	H13436	Seal
10 •	H14202	Seal
11 •	H14215	Seal
12	K322004	Junction Box Kit
13 •	K183012	Gasket

* Coil leads are 19" long.

• Parts included in Seal Kit K352064.

C

Inline Valves

Viking Lite

Viking Extreme

"B" Series

Air Saver Unit

ADEX Series

"N" Series



For inventory, lead time, and kit lookup, visit www.pdnplu.com

Coils for Pilot Operated Valves

The voltage code of the valve can be identified in the 10th and 11th digit of the valve part number.

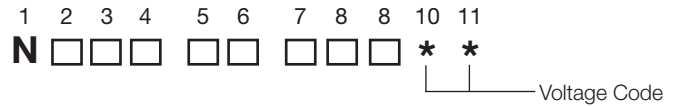

L-Pilot Valves

Voltage Code **	Voltage			Coil	
	60Hz	50Hz	DC	19" Leads	72" Leads
40	12	—	—	K593007	—
41,42	24	—	6	K593003	—
45*	—	—	12	K593010	—
49*	—	—	24 (Standard)	K593014	—
79	—	—	24 (Arc Suppressed)	K593271	—
51*	—	—	48	—	K593185
53*	120	110	—	K593025	—
57*	240	240	—	K593035	—
60	240	220	—	K593035	—
61	—	—	120	K593041	—

* Indicates voltages approved for solenoid operators designed for use in hazardous locations.

P-Pilot Valves

Voltage Code **	Voltage			Coil	
	60Hz	50Hz	DC	19" Leads	72" Leads
43	—	24	—	K593098	—
45	—	—	12	K593094	—
49	—	—	24	K593097	—
51	—	—	48	—	K593254
53	115	—	—	K593108	—
58	—	230	—	K593111	—

Solenoid Characteristics Chart

Voltage Range +10/-15% of Nominal

3/8" & 3/4" Basic – L-Pilot

Voltage/ Cycles	Amps Inrush	Amps Holding	Resistance		Insulation Class
			Ohms	Watts	
120/60VAC	.29	.18	122	12	B
110/50VAC	.21	.14	122	12	B
240/60VAC	.18	.12	610	12	B
24/50VAC	1.2	.75	6.4	9.5	B
6VDC	—	1.4	4.5	7.6	B
12VDC	—	.66	17.7	9	B
24VDC	—	.32	71	9	B
48VDC	—	.22	216	11	B

NOTE: Continuous duty type service is for applications where pilot valve is energized more than ten (10) minutes.

Solenoid Characteristics Chart

Voltage Range +10/-15% of Nominal

1-1/4" Basic – P-Pilot

Voltage/ Cycles	Amps Inrush	Amps Holding	Resistance		Insulation Class
			Ohms	Watts	
120/60VAC	.46	.25	35	18.5	B
110/50VAC	.36	.19	48	12	B
230/60VAC	.26	.15	125	19.5	B
220/50VAC	.20	.11	191	15	B
24/60VAC	2.3	1.4	1.3	20	B
24/50VAC	1.6	.9	2.1	12	B
12VDC	—	.7	17	8	B
24VDC	—	.33	68	8	B
48VDC	—	.16	275	7.5	B

NOTE: Continuous duty type service is for applications where pilot valve is energized more than ten (10) minutes.

Hazardous Duty Solenoid Listing

Valves with solenoid operators designed for hazardous locations are UL & CSA Approved as follows:

National Electric Code	Ambient Conditions	NEMA Classification
Class I Div. 1, Group C	Ethyl, Ether, Etc. Gases & Vapors	VII (7)
Class I Div. 1, Group D	Gasoline, Etc. Gases & Vapors	VII (7)
Class I Div. 2, Group B	Butadiene, Etc., Liquid, Fluid or Vapor Normally Contained, or Atmosphere Ventilated	VII (7)
Class II Div. 1, Group E	Metal Dust	IX (9)
Class II Div. 1, Group F	Coal, Coke, Carbon Black Dust	IX (9)
Class II Div. 1, Group G	Flour, Starch, Grain Dust	IX (9)

See Article 500 – Hazardous (Classified) Locations, National Electric Code.



For inventory, lead times, and kit lookup, visit www.pdnplu.com

Flow

Basic Valve Size	Inlet Port Size	Exhaust Port Size	Cv Inlet to Cylinder	Cv Cylinder to Exhaust
3/8" 3-Way, Normally Closed	3/8" Pipe	1/2" Pipe	3.6	4.2
	1/2" Pipe	1/2" Pipe	3.8	4.3
3/8" 3-Way, Normally Open	3/8" Pipe	1/2" Pipe	3.6	4.1
	1/2" Pipe	1/2" Pipe	3.9	4.5
3/4" 3-Way, Normally Closed	1/2" Pipe	3/4" Pipe	8.2	9.2
	3/4" Pipe	1" Pipe	9.3	10.8
3/4" 3-Way, Normally Open	1/2" Pipe	3/4" Pipe	7.7	6.6
	3/4" Pipe	1" Pipe	9.6	11.4
1-1/4" 3-Way, Normally Closed	1" Pipe	1-1/4" Pipe	19.5	23.5
	1-1/4" Pipe	1-1/2" Pipe	23.3	26.9
	1-1/2" Pipe	1-1/2" Pipe	23.3	26.9
1-1/4" 3-Way, Normally Open	1" Pipe	1-1/4" Pipe	20.4	24.8
	1-1/4" Pipe	1-1/2" Pipe	25.0	29.1
	1-1/2" Pipe	1-1/2" Pipe	26.7	29.9

Wiring Connections

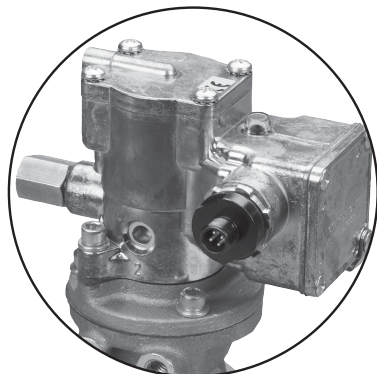

Chrysler Connection

4-Pin Male/Single Solenoid
 (Encl. Option J, Wiring Option C)

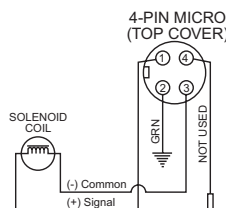

5-Pin Male/Single Solenoid
 (Encl. Option N, Wiring Option C)

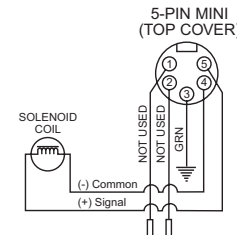

Automotive Connections

- 3-Pin & 5-Pin "Mini" (7/8 UNF Thread)
- 4-Pin "Micro" (M12 Thread)

Solenoid Configurations

"E", "J", "N"

Ford Connection

3-Pin Male/Single Solenoid
 (Encl. Option E, Wiring Option F)

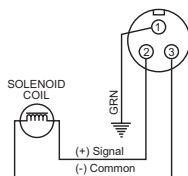

4-Pin Male/Single Solenoid
 (Encl. Option J, Wiring Option F)
 (Per ISO 202/01)

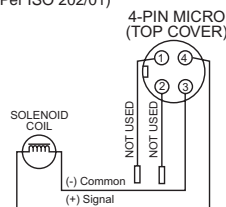

5-Pin Male/Single Solenoid
 (Encl. Option N, Wiring Option F)

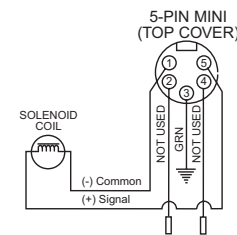

GM Connection

4-Pin Male/Single Solenoid
 (Encl. Option J, Wiring Option G)

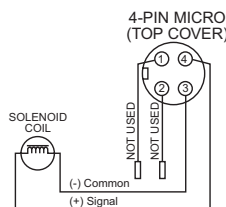

5-Pin Male/Single Solenoid
 (Encl. Option N, Wiring Option G)

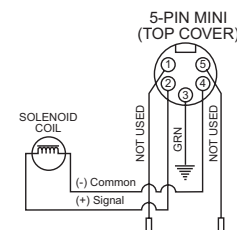

For inventory, lead time, and kit lookup, visit www.pdnplu.com

C
 Inline Valves
 Viking Lite
 Viking Extreme
 "B" Series
 Air Saver Unit
 ADEX Series
 "N" Series

Selection

Although reasonable safety factors are designed into each speed poppet valve, it is important that application requirements do not exceed the rated limitation of the valve. This precaution insures a sufficient safety factor.

Life Expectancy

Normal multimillion cycle life expectancy of high speed poppet series valves is based on the use of properly filtered and lubricated air at room temperature. In actual laboratory tests, the high speed poppet valves provide maintenance-free service life in excess of 20,000,000 cycles.

Lubrication

The high speed poppet valves are pre-lubricated to permit use with non-lubricated air. However, air should be lubricated to assure maximum seal life.

F442 lubricating oil is recommended. This oil is specially formulated to provide peak performance and maximum service life from air-operated equipment.

Other good air line lubricating oils may be used provided they atomize readily and are of the medium aniline type. Aniline point range must be between 180°F - 220°F. Viscosity SUS @ 100°F of 140-170. High aniline oils will shrink seals; low aniline oils will swell seals, reducing operating life and expectancy.

Installation

Valves should be installed with reasonable accessibility for service whenever possible. Care should be taken to hold piping length to a minimum and to protect valves from exposure to extreme heat, dirt and moisture. Piping should be clean and clear of dirt and chips. Threads should be the correct size and undamaged. Pipe joint compound should be used sparingly and only on pipe threads, never in the valve body. Care should be taken in installation to avoid undue strain on valve.

For the small port size options, it is recommended that an air reservoir is located close to the valve inlet as to not starve the valve of air pressure.

⚠ CAUTION: DO NOT RESTRICT THE INLET TO POPPET VALVES

Restriction of the inlet can starve the air supply to the pilot section of internally piloted poppet valves and result in slow shifting or failure of the valve to shift properly. Always connect the supply line directly to the inlet of the valve using the full pipe size of the valve inlet. Never use a quick coupling to connect a poppet valve to the air supply. On valves with a small inlet port, use of an upstream surge tank may be required at lower operating pressures to insure an adequate air supply and proper operation.

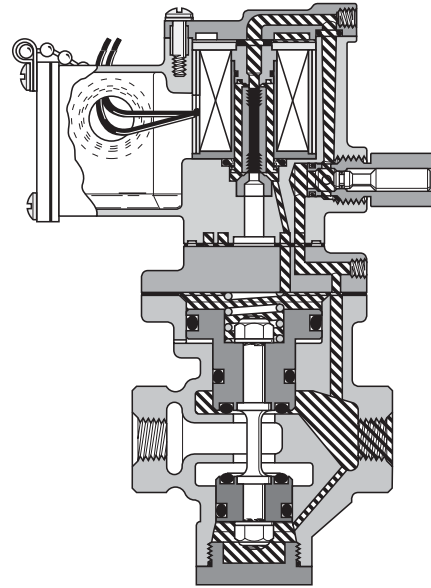

3/8" Solenoid Pilot De-Energized Normally Closed

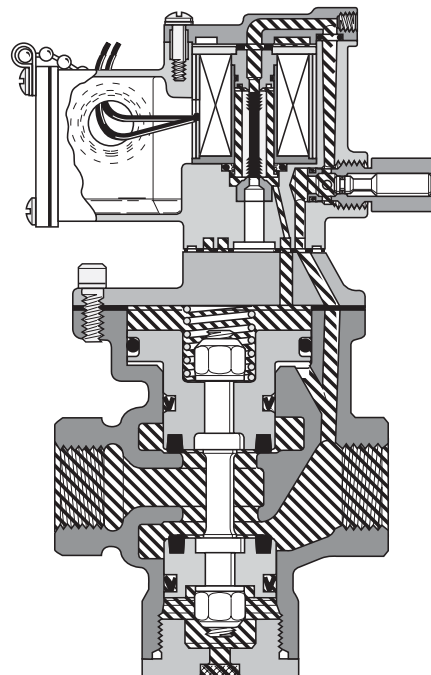

1-1/4" Solenoid Pilot De-Energized Normally Open

C	Inline Valves
	Viking Lite
	Viking Extreme
	"B" Series
	Air Saver Unit
	ADEX Series
	"N" Series

Internal Pilot - 3/8" & 3/4" Basic Body

Normally Closed

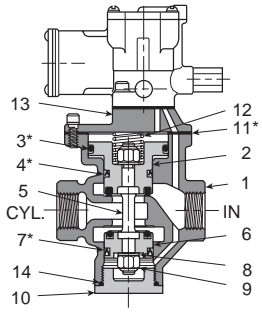

Normally Open

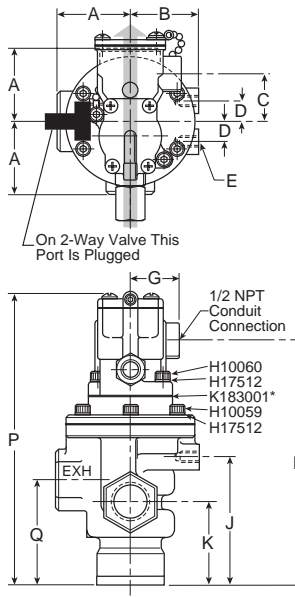
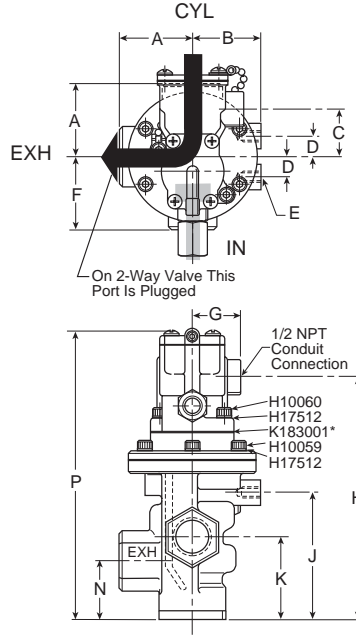
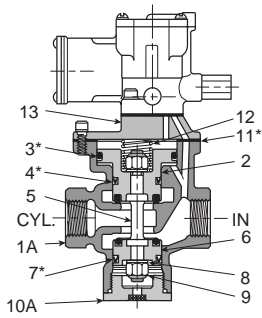

Exhaust
Pressure

Top view indicates flow through 3-Way valve with coil de-energized.

NOTE: For normal valve operation, override must be in "out" position.

**Internal Pilot -
3/8" & 3/4" Basic Body**

Key	3/8" Body		3/4" Body	
	Inch	mm	Inch	mm
A	1.56	40	2.13	54
B	1.50	38	1.94	49
C	1.81	46	1.34	34
D	.56	14	.56	14
E	3/8-16UNC 7/16" deep		3/8-16UNC 9/16" deep	
F	1.75	44	2.25	57
G	1.50	38	1.50	38
H	5.92	150	7.14	181
J	3.19	81	3.75	95
K	1.88	47	2.44	62
N	1.44	37	1.78	45
P	7.36	196	8.58	218
Q	2.31	59	3.09	84

Service Kits

Include all parts normally required for in-service maintenance:

- 3/8" Basic valve with standard service L-Pilots.....**K352076**
- 3/8" Basic valve with continuous duty L-Pilots.....**K352276**
- 3/4" Basic valve with standard service L-Pilots.....**K352077**
- 3/4" Basic valve with continuous duty L-Pilots.....**K352277**

Key	3/8" Valve	3/4" Valve	Description
1	—	1/2" Tap K053075	Body (N.C.)
	3/8" Tap K053022	3/4" Tap K053076	
	1/2" Tap K053023	1" Tap K053220	
1A	—	3/4" Tap K053077	Body (N.O.)
	3/8" Tap K053025	3/4" Tap K053078	
	1/2" Tap K053026	1" Tap K053218	
2	K212001	K212002	Upper piston assy
3*	H13648	H13728	Seal

Key	3/8" Valve	3/4" Valve	Description
4*	H14510	H13676	U-cup (3/8), o-ring (3/4)
5	K493002	K493009	Stem
6	K202001	K202002	Lower piston assy.
7*	H14509	H13676	U-cup (3/8), o-ring (3/4)
8	H17811	H17813	Washer (2)
9	H06326	H06332	Stop nut (2)
10	K103035	K103053	Bottom cap (N.C.)
10A	K092020	K092034	Bottom cap assy. (N.O.)
11*	K183049	K183057	Gasket
12	K473014	K473015	Spring
13	K563015	K563017	Adapter
14*	K41RB72121	K41RB72221	O-ring

* Parts included in seal kit



For inventory, lead time, and kit lookup, visit www.pdnplu.com

C

Inline Valves

Viking Lite

Viking Extreme

"B" Series

Air Saver Unit

ADEX Series

"N" Series

External Pilot - 3/8" & 3/4" Basic Body

Normally Closed

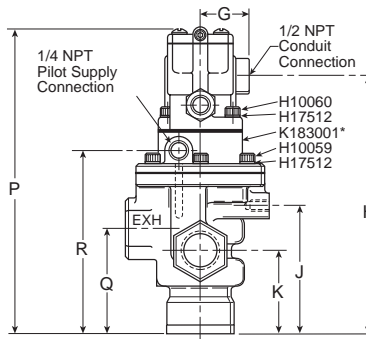
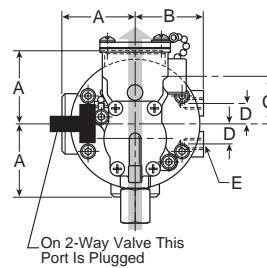
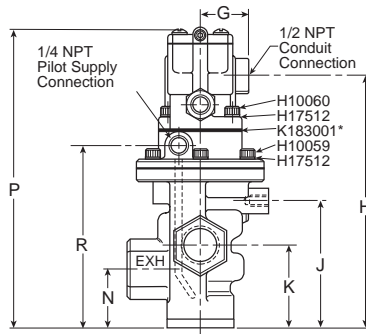
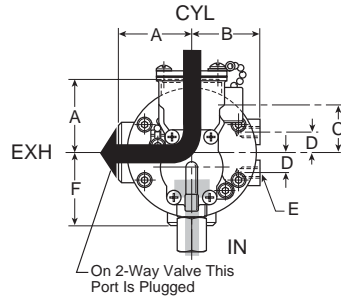
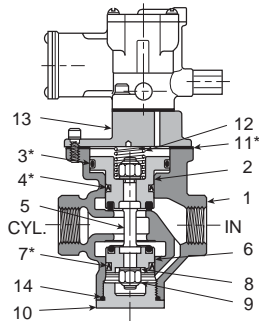

Normally Open

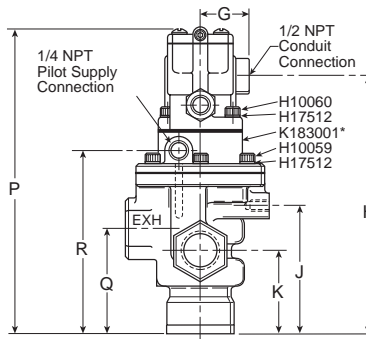
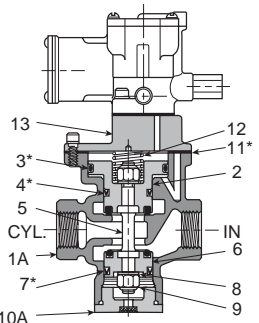

Exhaust
Pressure

Top view indicates flow through 3-Way valve with coil de-energized.

NOTE: For normal valve operation, override must be in "out" position.

**External Pilot -
3/8" & 3/4" Basic Body**

Key	3/8" Body		3/4" Body	
	Inch	mm	Inch	mm
A	1.56	40	2.13	54
B	1.50	38	1.94	49
C	1.81	46	1.34	34
D	.56	14	.56	14
E	3/8-16UNC 7/16" deep		3/8-16UNC 9/16" deep	
F	1.75	44	2.25	57
G	1.50	38	1.50	38
H	6.42	163	7.45	189
J	3.19	81	3.75	95
K	1.88	47	2.44	62
N	1.44	37	1.78	45
P	7.86	200	8.89	226
Q	2.31	59	3.09	84
R	4.34	110	5.38	137

Service Kits

Include all parts normally required for in-service maintenance:

- 3/8" Basic valve with standard service L-Pilots.....**K352076**
- 3/8" Basic valve with continuous duty L-Pilots.....**K352276**
- 3/4" Basic valve with standard service L-Pilots.....**K352077**
- 3/4" Basic valve with continuous duty L-Pilots.....**K352277**

Key	3/8" Valve	3/4" Valve	Description
	—	1/2" Tap K053067	
1	3/8" Tap K053019	3/4" Tap K053069	Body (N.C.)
	1/2" Tap K053157	1" Tap K053221	
	—	3/4" Tap K053065	
1A	3/8" Tap K053018	3/4" Tap K053070	Body (N.O.)
	1/2" Tap K053064	1" Tap K053219	
	2	K212001	
3*	H13648	H13728	Seal

Key	3/8" Valve	3/4" Valve	Description
4*	K41RB72211	H13676	O-ring
5	K493002	K493009	Stem
6	K202001	K202002	Lower piston assy.
7*	K41RB72210	H13676	O-ring
8	H17811	H17813	Washer (2)
9	H06326	H06332	Stop nut (2)
10	K103035	K103053	Bottom cap (N.C.)
10A	K092020	K092034	Bottom cap assy. (N.O.)
11	K473014	K473015	Spring
12*	K183049	K183057	Gasket
13	K563016	K563021	Adapter
14*	K41RB72121	K41RB72221	O-ring

* Parts included in seal kit

C
 Inline Valves
 Viking Lite
 Viking Extreme
 "B" Series
 Air Saver Unit
 ADEX Series
 "N" Series



For inventory, lead times, and kit lookup, visit www.pdnplu.com

Internal Pilot - 1-1/4" Basic Body

Normally Closed

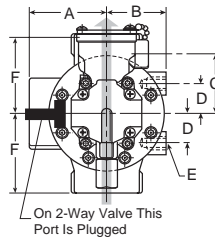
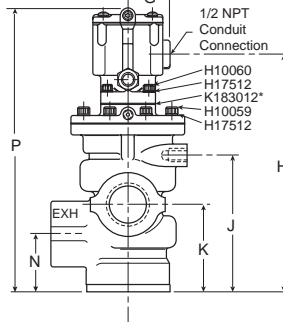
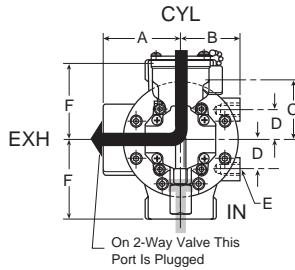
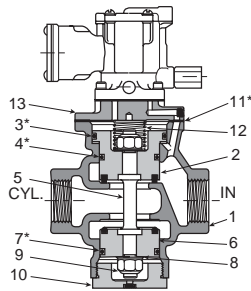

Normally Open

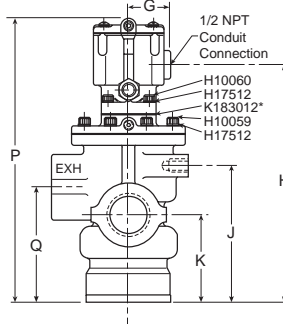
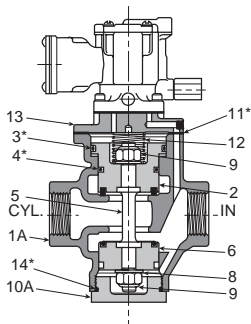

Exhaust
Pressure

Top view indicates flow through 3-Way valve with coil de-energized.

NOTE: For normal valve operation, override must be in "out" position.

**Internal Pilot -
1-1/4" Basic Body**

Key	1-14" Body	
	Inch	mm
A	3.00	76
B	2.25	57
C	1.34	34
D	1.19	30
E	1/2-13 UNC	3/4 Deep
F	3.13	80
G	1.50	38
H	9.30	236
J	5.34	136
K	3.44	87
N	2.31	59
P	11.14	283
Q	4.56	116

Service Kits

Include all parts normally required for in-service maintenance:

1-1/4" Basic valve with standard service P-Pilots **K352078**

Key	1-1/4" Valve	Description
1	1" Tap K053111	Body (N.C.)
	1-1/4" Tap K053112	
	1-1/2" Tap K053113	
1A	1" Tap K053114	Body (N.O.)
	1-1/4" Tap K053115	
	1-1/2" Tap K053116	
2	K313029	Upper piston assy
3*	H13752	O-ring

Key	1-1/4" Valve	Description
4*	H13728	Seal
5	K493016	Stem
6	K313028	Lower piston
7*	H13728	Seal
8	H17817	Washer
9	H06338	Stop nut
10	K092046	Bottom cap (N.C.)
10A	K103061	Bottom cap (N.O.)
11*	K183058	Gasket
12	K473016	Spring
13	K012003	Adapter
14*	K41RB72143	O-ring

* Parts included in seal kit



For inventory, lead time, and kit lookup, visit www.pdnplu.com

C109

Parker Hannifin Corporation
Pneumatic Division
Richland, Michigan
www.parker.com/pneumatics

C

Inline Valves

Viking Lite

Viking Extreme

"B" Series

Air Saver Unit

ADEX Series

"N" Series

Continuous Duty Pilot - 1-1/4" Basic Body

Normally Closed

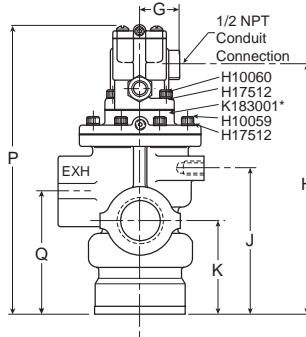
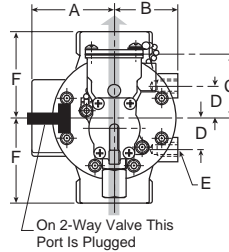
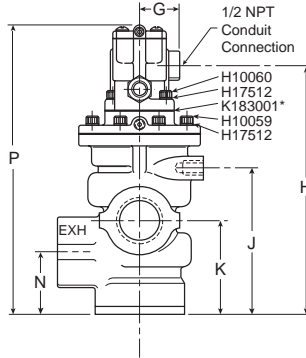
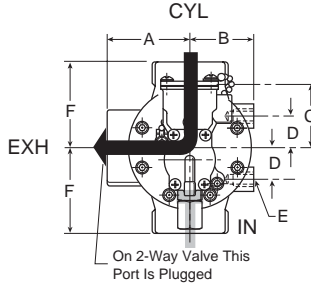
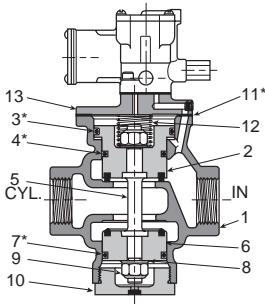

Normally Open

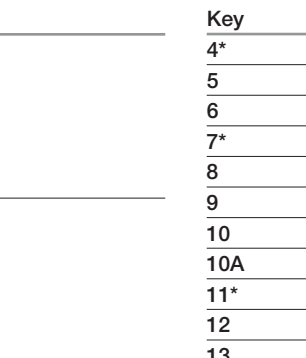
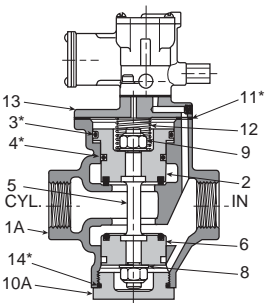

Exhaust
Pressure

Top view indicates flow through 3-Way valve with coil de-energized.

NOTE: For normal valve operation, override must be in "out" position.

Continuous Duty Pilot - 1-1/4" Basic Body

Key	1-1/4" Body	
	Inch	mm
A	3.00	76
B	2.25	57
C	1.34	34
D	1.19	30
E	1/2-13 UNC	3/4 Deep
F	3.13	80
G	1.50	38
H	9.02	229
J	5.34	136
K	3.44	87
N	2.31	59
P	10.45	265
Q	4.56	116

Service Kits

Include all parts normally required for in-service maintenance:

1-1/4" Basic valve with continuous duty L-Pilot.....**K352080**

Key	1-1/4" Valve	Description
	1" Tap K053111	
1	1-1/4" Tap K053112	Body (N.C.)
	1-1/2" Tap K053113	
	1" Tap K053114	
1A	1-1/4" Tap K053115	Body (N.O.)
	1-1/2" Tap K053116	
	2	
3*	H13752	O-Ring

Key	1-1/4" Valve	Description
4*	H13728	Seal
5	K493016	Stem
6	K313028	Lower piston
7*	H13728	Seal
8	H17817	Washer
9	H06338	Stop nut
10	K092046	Bottom cap (N.C.)
10A	K103061	Bottom cap (N.O.)
11*	K183058	Gasket
12	K473016	Spring
13	K012003	Adapter
14*	K41RB72143	O-ring

* Parts included in seal kit

C
 Inline Valves
 Viking Lite
 Viking Extreme
 "B" Series
 Air Saver Unit
 ADEX Series
 "N" Series



For inventory, lead times, and kit lookup, visit www.pdnplu.com

Internal Return - 3/8", 3/4", 1-1/4" Basic Body

Normally Closed

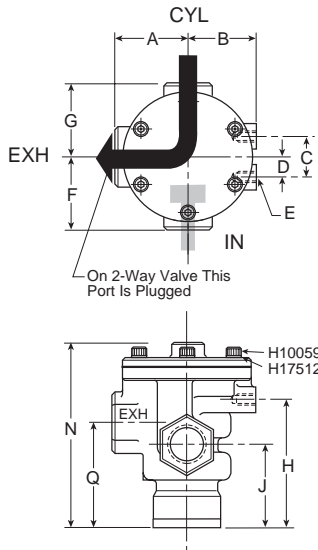
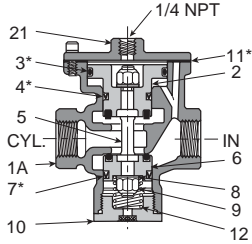

Normally Open

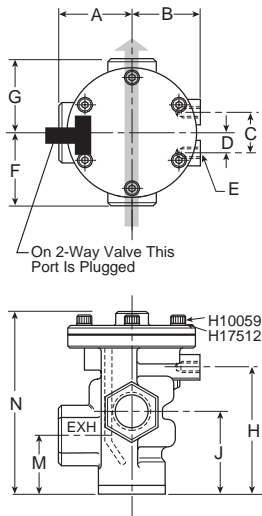
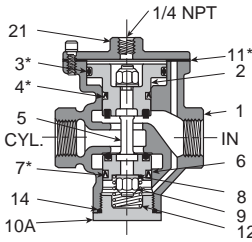

Exhaust
Pressure

Top view indicates flow through 3-Way valve.

NOTE: For normal valve operation, override must be in "out" position.

Internal Return - 3/8", 3/4", 1-1/4" Basic Body

Key	3/8" Body		3/4" Body		1-1/4" Body	
	Inch	mm	Inch	mm	Inch	mm
A	1.56	40	2.13	54	3.00	76
B	1.50	38	1.94	49	2.25	57
C	1.13	29	1.13	29	2.38	60
D	.56	14	.56	14	1.19	30
E	3/8-16UNC 7/16" deep		3/8-16UNC 9/16" deep		1/2-13UNC 3/4" deep	
F	1.75	44	2.25	57	3.13	79
G	1.56	40	2.13	54	3.13	79
H	3.19	81	3.75	95	5.34	136
J	1.88	48	2.44	62	3.44	87
M	1.44	37	1.78	45	2.66	67
N	4.22	107	5.31	135	7.19	183
Q	2.31	59	3.09	78	4.56	116

Service Kits

Include all parts normally required for in-service maintenance:

- 3/8" Basic valve.....**K352073**
- 3/4" Basic valve.....**K352074**
- 1-1/4" Basic valve**K352075**

Key	3/8" Valve	3/4" Valve	1-1/4" Valve	Description
1	—	1/2" Tap K053075	1" Tap K053111	Body (N.O.)
	3/8" Tap K053022	3/4" Tap K053076	1-1/4" Tap K053112	
	1/2" Tap K053023	1" Tap K053220	1-1/2" Tap K053113	
1A	—	1/2" Tap K053077	1" Tap K053114	Body (N.C.)
	3/8" Tap K053025	3/4" Tap K053078	1-1/4" Tap K053115	
	1/2" Tap K053026	1" Tap K053218	1-1/2" Tap K053116	
2	K212001	K212002	K313029	Upper piston assy
3*	H13648	H13728	H13752	Seal
4*	H14510	H13676	H13728	Seal

Key	3/8" Valve	3/4" Valve	1-1/4" Valve	Description
5	K493002	K493009	K493016	Stem
6	K202001	K202002	K313028	Lower piston assy.
7*	H13499	H13676	H13728	Seal
8	H17811	H17813	H17817	Washer (2)
9	H06326	H06332	H06338	Stop nut (2)
10	K092020	K092034	K092046	Bottom cap (N.C.)
10A	K103035	K103053	K103061	Bottom cap (N.O.)
11*	K183049	K183057	K183058	Gasket
12	K473014	K473015	K473016	Spring
14*	K41RB72121	K41RB72221	K41RB72143	O-ring
21	K123018	K123021	K123024	Cover

* Parts included in seal kit



For inventory, lead time, and kit lookup, visit www.pdnplu.com

External Return - 3/8", 3/4", 1-1/4" Basic Body

Normally Closed

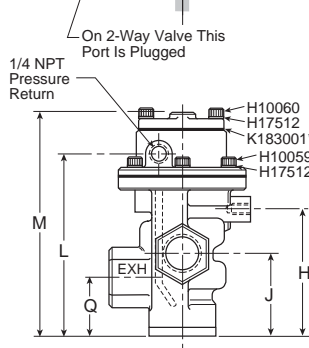
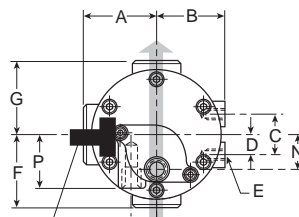
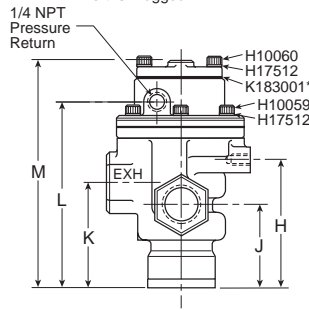
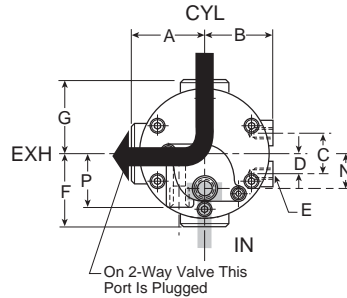
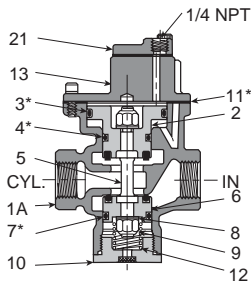

Normally Open

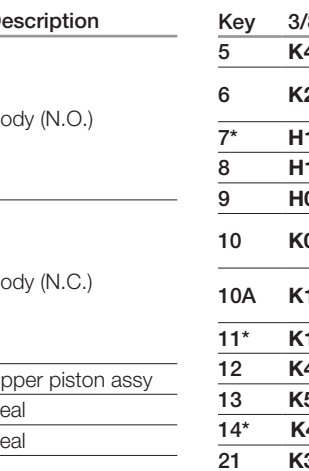
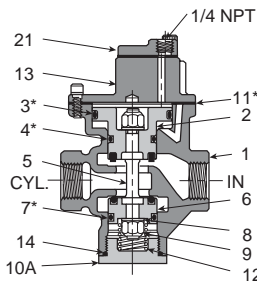

Exhaust
Pressure

Top view indicates flow through 3-Way valve.

NOTE: For normal valve operation, override must be in "out" position.

Internal Return - 3/8", 3/4", 1-1/4" Basic Body

Key	3/8" Body		3/4" Body		1-1/4" Body	
	Inch	mm	Inch	mm	Inch	mm
A	1.56	40	2.13	54	3.00	76
B	1.50	38	1.94	49	2.25	57
C	1.13	29	1.13	29	2.38	60
D	.56	14	.56	14	1.19	30
E	3/8-16UNC 7/16" deep		3/8-16UNC 9/16" deep		1/2-13UNC 3/4" deep	
F	1.75	44	2.25	57	3.13	79
G	1.56	40	2.13	54	3.13	79
H	3.19	81	3.75	95	5.34	136
J	1.88	48	2.44	62	3.44	87
K	2.31	59	3.09	78	4.56	116
L	4.34	110	5.38	137	7.31	186
M	5.31	135	6.34	161	7.88	200
N	Left of center			On center		
Q	1.44	37	1.78	45	2.31	59

Service Kits

Include all parts normally required for in-service maintenance:

- 3/4" Basic valve.....**K352056**
- 1-1/4" Basic valve**K352083**

Key	3/8" Valve	3/4" Valve	1-1/4" Valve	Description
1	1/4" Tap K053011	1/2" Tap K053067	1" Tap K053143	Body (N.O.)
	—	3/4" Tap K053069	—	
1A	1/2" Tap K053157	1" Tap K053221	1-1/2" Tap K053146	Body (N.C.)
	1/4" Tap K053010	1/2" Tap K053065	1" Tap K053159	
2	—	3/4" Tap K053070	1-1/4" Tap K053144	Upper piston assy
	1/2" Tap K053064	1" Tap K053219	1-1/2" Tap K053145	
3*	H13648	H13728	H13752	Seal
4*	H13529	H13676	H13728	Seal

Key	3/8" Valve	3/4" Valve	1-1/4" Valve	Description
5	K493002	K493009	K493016	Stem
6	K202001	K202002	K313028	Lower piston assy.
7*	H13499	H13676	H13728	Seal
8	H17811	H17813	H17817	Washer (2)
9	H06326	H06332	H06338	Stop nut (2)
10	K092020	K092034	K092046	Bottom cap assy. (N.C.)
10A	K103035	K103053	K103061	Bottom cap (N.O.)
11*	K183049	K183057	K183058	Gasket
12	K473014	K473015	K473016	Spring
13	K563016	K563021	K563027	Adapter
14*	K41RB72121	K41RB72221	K41RB72143	O-ring
21	K323027	K323027	Not used	Cover

* Parts included in seal kit



For inventory, lead times, and kit lookup, visit www.pdnplu.com

Internal Return - 3/8", 3/4" & 1-1/4" Basic Body

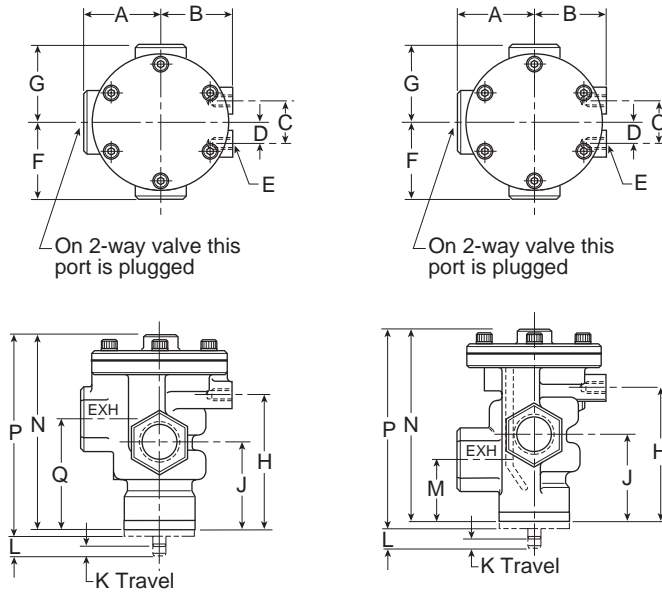

Internal Return - 3/8", 3/4" & 1-1/4" Basic Body

Key	3/8" Body		3/4" Body		1-1/4" Body	
	Inch	mm	Inch	mm	Inch	mm
A	1.56	40	2.13	54	3.00	76
B	1.50	38	1.94	49	2.25	57
C	1.13	29	1.13	29	2.38	60
D	.56	14	.56	14	1.19	30
E	3/8-16UNC 7/16" deep		3/8-16UNC 9/16" deep		1/2-13UNC 3/4" deep	
F	1.75	44	2.25	57	3.13	79
G	1.56	40	2.13	54	3.13	79
H	3.19	81	3.75	95	5.34	136
J	1.88	48	2.44	62	3.44	87
K	.50	13	.50	13	.50	13
L	.11	3	.16	4	.25	6
M	1.44	37	1.78	45	2.66	67
N	4.22	107	5.31	135	7.19	183
P	4.78	121	5.56	141	7.53	191
Q	2.31	59	3.09	78	4.56	116

External Return - 3/8", 3/4" & 1-1/4" Basic Body

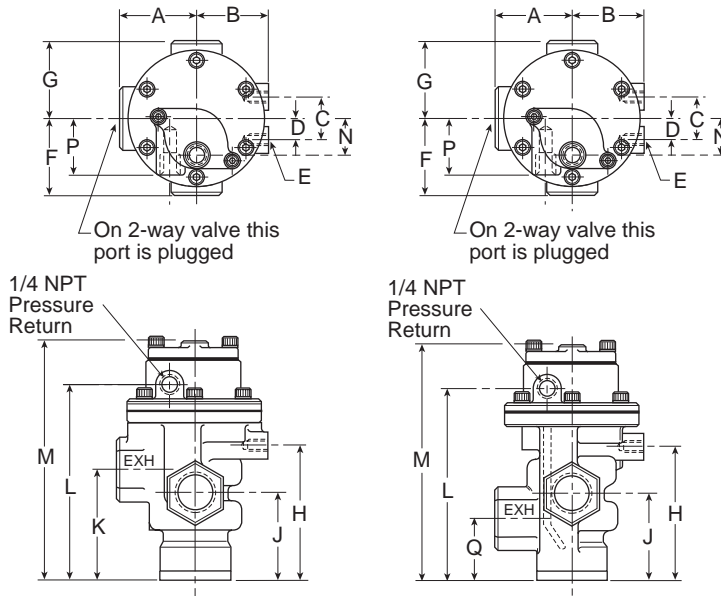

External Return - 3/8", 3/4" & 1-1/4" Basic Body

Key	3/8" Body		3/4" Body		1-1/4" Body	
	Inch	mm	Inch	mm	Inch	mm
A	1.56	40	2.13	54	3.00	76
B	1.50	38	1.94	49	2.25	57
C	1.13	29	1.13	29	2.38	60
D	.56	14	.56	14	1.19	30
E	3/8-16UNC 7/16" deep		3/8-16UNC 9/16" deep		1/2-13UNC 3/4" deep	
F	1.75	44	2.25	57	3.13	79
G	1.56	40	2.13	54	3.13	79
H	3.19	81	3.75	95	5.34	136
J	1.88	48	2.44	62	3.44	87
K	2.31	59	3.09	78	4.56	116
L	4.34	110	5.38	137	7.31	186
M	5.31	135	6.34	161	7.88	200
N	Left of center .53 13		On center 1.00 25			
Q	1.44	37	1.78	45	2.31	59

C

Inline Valves

Viking Lite

Viking Extreme

"B" Series

Air Saver Unit

ADEX Series

"N" Series

C

Inline Valves

Viking
Lite

Viking
Extreme

"B"
Series

Air Saver
Unit

ADEX
Series

"N"
Series



For inventory, lead times, and kit lookup, visit www.pdnplu.com

C114

Parker Hannifin Corporation
Pneumatic Division
Richland, Michigan
www.parker.com/pneumatics

Pneumatic Valve Products
Subbase and Manifold Valve Series

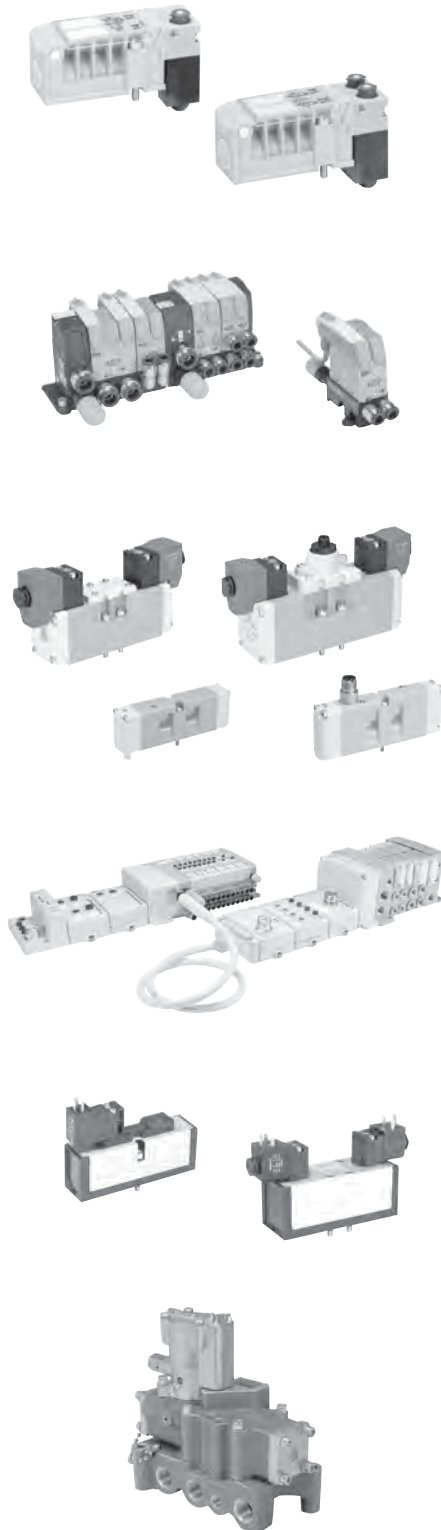

H Series Micro

Features	D2-D3
Common Part Numbers	D4-D5
Ordering Information	D6-D11
Accessories	D12
Technical / Dimensional Data	D13-D27

Moduflex Series

Features	D28-D32
Common Part Numbers / Ordering Information	D33-D45
Technical Data	D46-D66
Dimensional Data	D67-D71

H Series ISO

Plug-In	
15407-2, Size 02 & 01	D72-D73
5599-2, Size 1, 2, 3	D85-D100
Non Plug-In	
15407-1, Size 02 & 01	D101-D107
5599-1, Size 1, 2, 3	D108-D122
Technical Data / Accessories	D123-D130
Dimensional Data	D131-D137

Fieldbus

Features	D138
Moduflex	D139-D146
H Series	D147-D163
Turck	D164-D183
Accessories / Cables	D184-D187
Technical / Dimensional Data	D188-D202

DX Series

Features	D203
Non Plug-In	
15407-1, Size 02 & 01	D204-D214
5599-1, Size 1, 2, 3	D215-D225
Technical Data / Accessories	D225-D239
Dimensional Data	D240-D246

Valvair II Series

Features	D247
Common Part Numbers / Ordering Information	D248-D253
Technical Data / Accessories	D254-D261
Dimensional Data	D262-D272

D

Subbase & Manual Valves



For inventory, lead time, and kit lookup, visit www.pdnplu.com

Features

H Series Micro

The H Series Micro Valve System incorporates a space saving back to back valve mounting design, and achieves flow rates of 0.35 Cv per valve with 4 valves having a combined width of 42mm. This plug-in valve solution simplifies wiring with the use of 25 pin connectors or fieldbus systems.

Ports

- M7 on manifolds
- 3/8 Inch on end plates

Mounting

- Manifold

Solenoids

- 24 VDC, 1.0 watt

Certification / approval

- IP65 rated
- EMC / CE Mark: According to EN 61 000-6-2

Material specifications

Body	Polyamide reinforced fiberglass
End plates	Aluminum
Fasteners	Zinc plated steel
Manifolds	Aluminum
Spool	Brass and nitrile rubber
Spool enclosure	Brass



Operating information

Operating pressure: Vacuum to 120 PSIG (Vacuum to 8.2 bar)

Temperature range: 5°F to 120°F (-15°C to 49°C)

2-Position & Dual 3/2

0.35 Cv
C = 1.2 NI/s x bar, b = 0.13
Qn = 282 NI/min
Qmax = 510 NI/min

3-Position

0.30 Cv
C = 1 NI/s x bar, b = 0.13
Qn = 228 NI/min
Qmax = 402 NI/min

Pilot pressure requirements:

Valve number	Minimum pilot pressure	Maximum pilot pressure
HMEVX2049A	40 PSI	120 PSI
HM2VX2049A	25 PSI	120 PSI
HM5VX2049A	45 PSI	120 PSI
HMNVX2049A	40 PSI	120 PSI
HMPVX2049A	40 PSI	120 PSI
HMQVX2049A	40 PSI	120 PSI

D
 Subbase & Manual Valves
 H Series Micro
 Moduteflex Series
 H Series ISO
 Fieldbus Systems
 DX ISOMAX Series
 Valvair II Series

Wear Compensation System

Maximum Performance

- Low Friction
- Lower Operating Pressures
- Fast Response
- Less Wear

Long Cycle Life - Under pressure, radial expansion of the seal occurs to maintain sealing contact with the valve bore.

Non-Lube Service - No lubrication required for continuous valve shifting.

Bi-Directional Spool Seals - Common spool used for any pressure, including vacuum.

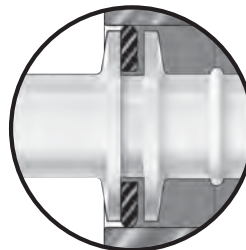

For inventory, lead times, and kit lookup, visit www.pdnplu.com

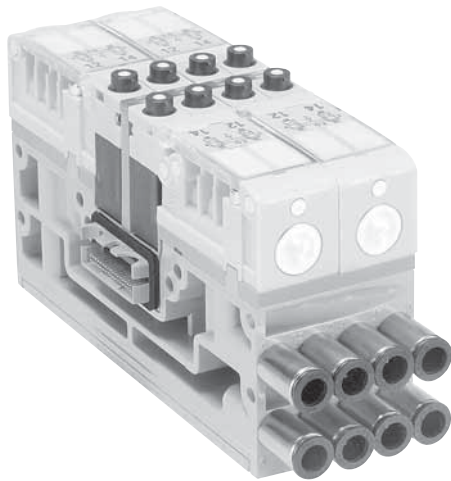

Innovative Product Design

- Back to back valve mounting design centralizes wiring in the manifold
- 4 valves on a 42mm wide manifold provides a 10.5mm wide valve solution with a reduced cost
- High flow of 0.35 Cv allows for broad application use
- Plug-in valve electronics reduce and eliminate wiring system costs
- Multiple pressure zones for many applications on the same manifold

Standard Features

- Integrated LED's identify when solenoids are active
- Side and bottom porting options on manifolds and end plates for versatile mounting
- All valve functions available for complete product offering
- Valves can be arranged in any combination for maximum flexibility
- Internal and external pilot options available for vacuum to 145 PSI applications
- IP65 protection enables direct machine mounting
- Product identification, valve function, and port description tags are standard on every manifold and are clearly visible thru a protective cover
- User configurable overrides for non-locking, locking, or no override options

Manifold Platforms

- 25 pin D-sub manifolds for control systems with discrete Outputs
- IO-Link Type A & Type B communication modules
- Cost effective moduflex fieldbus manifolds for control systems with DeviceNet™, Profibus®, Interbus and CANopen fieldbus and no inputs or outputs near valves
- Cost effective moduflex fieldbus manifolds with AS-i communication offer both Inputs and solenoid control
- Fully functional H Series fieldbus manifolds for control systems with inputs and outputs attached to the valve manifold
- Enhanced H Series bus expansion allows 4 H Series fieldbus valve manifolds to be connected to a single communication module significantly reducing costs on large machines
- Rockwell Automation RS Logix 5000™ users can take Advantage of Preferred Connectivity, by using the preloaded device profiles

Complete Assemblies

- All products offered as component level parts for individual assembly
- Simple manifolds offer sub-assembly level products with valves and fittings attached to manifold bases in a single part number
- Add-a-fold systems offer complete assemblies; including valves, manifolds, end plates, fittings, and mufflers in as few as 2 part numbers

D

Subbase & Manual Valves

H Series Micro

Moduflex Series

H Series ISO

Fieldbus Systems









DX ISOMAX Series

Valvair II Series

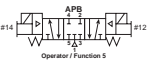

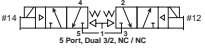
For inventory, lead time, and kit lookup, visit www.pdnplu.com

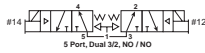
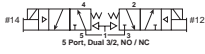
H Series Micro Valves

	Symbol	Type	Cv	Operator	Part number
		4-way, 2-position	0.35	Single solenoid	HMEVX2049A
		4-way, 2-position	0.35	Double solenoid	HM2VX2049A
		4-way, 3-position, all ports blocked	0.3	Double solenoid	HM5VX2049A
		3-way, 2-position, dual valve, NC/NC	0.35	Double solenoid	HMNVX2049A
		3-way, 2-position, dual valve, NO/NO	0.35	Double solenoid	HMPVX2049A
		3-way, 2-position, dual valve, NO/NC	0.35	Double solenoid	HMQVX2049A
		Blanking plate	N/A	N/A	HMBVX00XXA
		Intermediate air supply	N/A	N/A	HMCVX00XXA

- All valves, except double solenoid 2-position, ship with multi functional overrides. Standard valve configuration is non-locking manual override. Each solenoid can be configured for locking override or no override with the included manual override caps.
- All valve options include an LED, which is built into the manifold.
- All valve options pull pilot pressure from the manifold. The manifold assembly can be configured for internal or external pilot on the end plate.

Manifold Bases

	Part numbers				
Plug-in valve manifolds					
Single solenoid outputs only	<table border="1"> <tr> <th>Side port</th> <th>Bottom port</th> </tr> <tr> <td>PSM21JAP</td> <td>PSM22JAP</td> </tr> </table>	Side port	Bottom port	PSM21JAP	PSM22JAP
Side port	Bottom port				
PSM21JAP	PSM22JAP				
Double or single solenoid outputs	<table border="1"> <tr> <th>Side port</th> <th>Bottom port</th> </tr> <tr> <td>PSM21MAP</td> <td>PSM22MAP</td> </tr> </table>	Side port	Bottom port	PSM21MAP	PSM22MAP
Side port	Bottom port				
PSM21MAP	PSM22MAP				

Each manifold holds 4 H Series Micro Valves. Double address circuit boards contain outputs for 8 solenoids, and can be used with any valve. When a single solenoid valve is used, one address is not used but is still present on the manifold. Single address circuit boards contain outputs for 4 solenoids. Only single solenoid valves can be used.

 Most popular.









D
Subbase & Manual Valves
H Series Micro
Modutrex Series
H Series ISO
Fieldbus Systems
DX ISOMAX Series
Valvair II Series



For inventory, lead times, and kit lookup, visit www.pdnplu.com

Common Part Numbers

Internal Pilot End Plate Kits

	Electrical option	Porting	Side port	Bottom port
	25-pin, D-sub	NPT	PSML25AP	PSML26AP
		BSPP	PSML21AP	PSML22AP
	Turck fieldbus with valve driver module - 16 outputs	NPT	PSMT15AP	PSMT16AP
		BSPP	PSMT11AP	PSMT12AP
	Turck fieldbus with valve driver module - 32 outputs	NPT	PSMT25AP	PSMT26AP
		BSPP	PSMT21AP	PSMT22AP
	Moduflex up to 24 outputs	NPT	PSMM45AP	PSMM46AP
		BSPP	PSMM41AP	PSMM42AP
	H Series Fieldbus with valve driver module	NPT	PSML65AP	PSML66AP
		BSPP	PSML61AP	PSML62AP
	H Series Fieldbus with valve driver module and bus extension connector	NPT	PSMM55AP	PSMM56AP
		BSPP	PSMM51AP	PSMM52AP
	H Series Fieldbus with valve driver module and 24VDC connector	NPT	PSMM65AP	PSMM66AP
		BSPP	PSMM61AP	PSMM62AP
	H Series Fieldbus with valve driver module, bus extension connector and 24VDC connector	NPT	PSMM75AP	PSMM76AP
		BSPP	PSMM71AP	PSMM72AP

 Most popular.



For inventory, lead time, and kit lookup, visit www.pdnplu.com

Ordering Information

Simple Manifold Assemblies

Includes a valve manifold with 4 valves and fittings installed.
End Plates must be ordered separately.

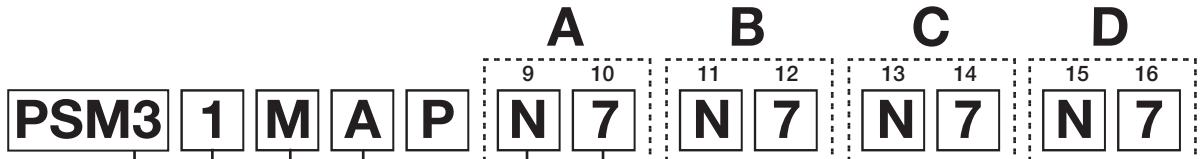

Base style	
4-Station manifold with valve and / or fitting	PSM3

Mounting style	
Side ported	1
Bottom ported	2

Enclosure / Lead length	
Single address circuit board	J
Double address circuit board	M

Engineering level	
Current	A

10, 12, 14, 16 Fitting	
0	Without fitting
4	Straight fitting for 5/32 inch or 4mm OD tube
6	Straight fitting for 6mm OD tube
7	Straight fitting for 1/4 inch OD tube
P	Plug for blanking module

9, 11, 13, 15 Valve type	
N*	Double solenoid, dual 3/2, NC/NC
P*	Double solenoid, dual 3/2, NO/NO
Q*	Double solenoid, dual 3/2, 14 end NO - 12 end NC
E	Single solenoid, 2-position - air return, spring assist
2*	Double solenoid, 2-position
5*	Double solenoid, 3-position - APB
B**	Blanking module
C	Intermediate air supply module

* Requires double address circuit board, enclosure "M".
** Requires fitting "P".

D
 Subbase & Manual Valves
 H Series Micro
 Moduteflex Series
 H Series ISO
 Fieldbus Systems
 DX ISOMAX Series
 Valvair II Series

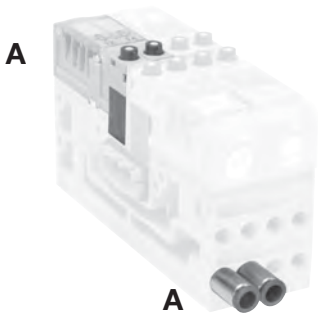

Valve Position A - Character 9
Fitting Position A - Character 10

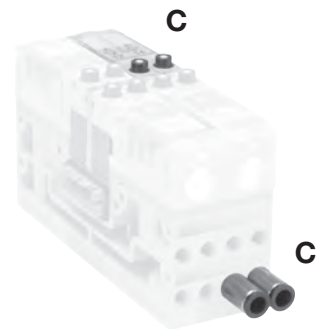

Valve Position C - Character 13
Fitting Position C - Character 14

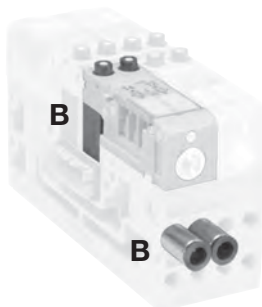

Valve Position B - Character 11
Fitting Position B - Character 12

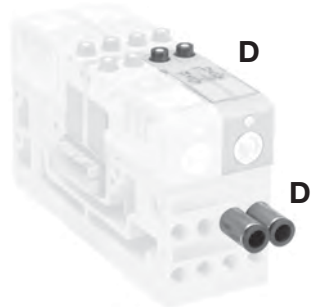

Valve Position D - Character 15
Fitting Position D - Character 16

Most popular.



For inventory, lead times, and kit lookup, visit www.pdnplu.com

Plug-in End Plate Kits

BOLD OPTIONS ARE MOST POPULAR.

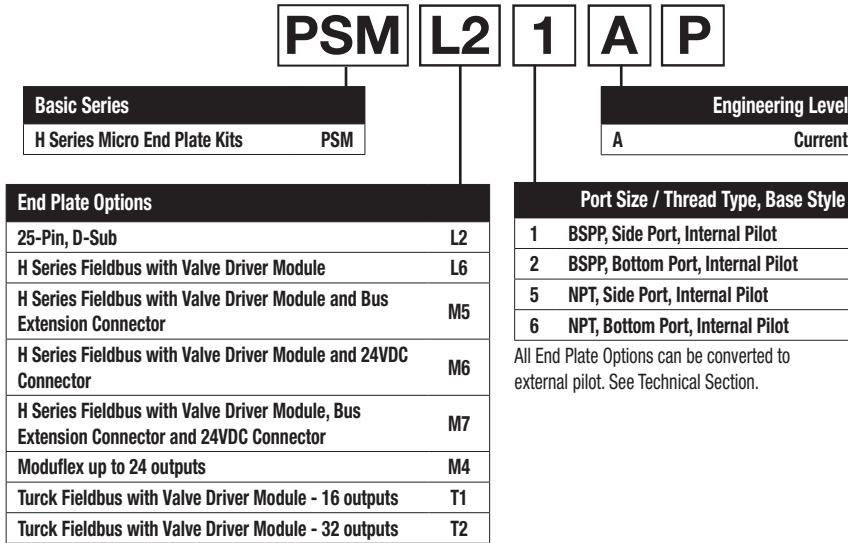

All End Plate Options can be converted to external pilot. See Technical Section.

Turck, H Series Fieldbus, and Moduflex communication modules must be ordered separately. See Fieldbus Section for more information.

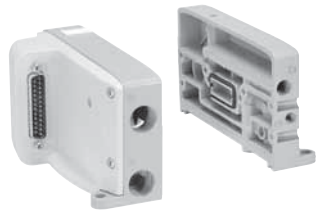

L2: 25-Pin, D-Sub End Plates



L6: H Series Fieldbus End Plates

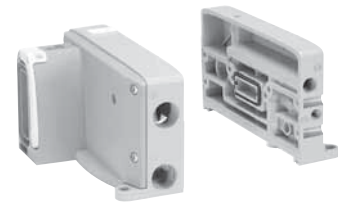

M4: Moduflex Fieldbus End Plates



M5: H Series Fieldbus with Bus Extension End Plates



M6: H Series Fieldbus with 24VDC Connector End Plates



M7: H Series Fieldbus with Bus Extension & 24VDC Connector End Plates

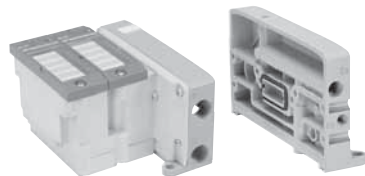

T1, T2: H Series Micro Turck End Plates

Valve power supply connector
 (As seen on module)

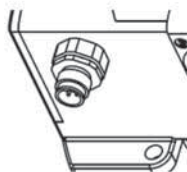

M12 Male (A coding)

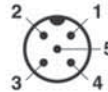

Pin 1 - 24 VDC valve
 Pin 2 - Not connected
 Pin 3 - 0 VDC valve
 Pin 4 - Not connected
 Pin 5 - Protective Earth (PE)

Local bus connector
 (As seen on module)

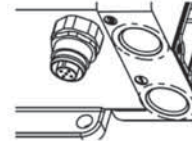

M12 Female (A coding)

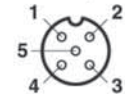

Pin 1 - CAN SHLD
 Pin 2 - CAN V+ (24 VDC)
 Pin 3 - CAN GND
 Pin 4 - CAN H
 Pin 5 - CAN L



For inventory, lead time, and kit lookup, visit www.pdnplu.com

Ordering Information

How To Order Plug-in Add-A-Fold Assemblies

1. List Add-A-Fold Assembly call out. This automatically includes the end plate kit assembly.
2. List Simple Manifold Assemblies. List left to right, LOOKING AT THE CYLINDER PORTS on the manifold.

**Maximum Number of Solenoids
(Maximum Energized Simultaneously)**

24VDC	25-pin D-sub	Moduflex	H Series Fieldbus*	Turck	
				16 Outputs	32 Outputs
	24 (24)	24 (24)	32 (32)	16 (16)	32 (32)

* Maximum of 32 solenoids per manifold. With Bus Extension functionality, 4 manifolds with up to 32 solenoids each can be connected on the same network.

Add-A-Fold Assembly Model Number

AAHM D 3 24 0 0 0 0

Valve series	
H Series micro add-a-fold	AAHM

End plate option	
Turck fieldbus with valve driver module - 16 outputs	A
Turck fieldbus with valve driver module - 32 outputs	B
25-pin, D-sub - 24 outputs	D
H Series Fieldbus with valve drive module - 32 outputs	Y
H Series Fieldbus with valve drive module and bus extension connector - 32 outputs	W
H Series Fieldbus with valve drive module and 24VDC connector - 32 outputs	X
H Series Fieldbus with valve drive module and bus extension and 24VDC connector - 32 outputs	Z
Moduflex - up to 24 outputs	T

H Series Fieldbus and Moduflex communication modules must be ordered separately.

Pilot exhaust on end plate		
0	Without fitting	
M	Muffler	
4	Straight fitting for 4mm OD tube	BSPP Threads
6	Straight fitting for 6mm OD tube	
4	Straight fitting for 5/32 inch OD tube	NPT Threads
7	Straight fitting for 1/4 inch OD tube	

M7 pilot port on end plate		
Internal pilot end plate		
0	With standard plug	
External pilot end plate		
0	Without fitting	
4	Straight fitting for 4mm OD tube	BSPP Threads
6	Straight fitting for 6mm OD tube	
4	Straight fitting for 5/32 inch OD tube	NPT Threads
7	Straight fitting for 1/4 inch OD tube	

End plate type		
BSPP Threads	BSPP side port, internal pilot	1
	BSPP bottom port, internal pilot	2
	BSPP side port, external pilot	3
	BSPP bottom port, external pilot	4
NPT Threads	NPT side port, internal pilot	5
	NPT bottom port, internal pilot	6
	NPT side port, external pilot	7
	NPT bottom port, external pilot	8

3/8" exhaust on end plate		
0	Without fitting	
M	Muffler	
8	Straight fitting for 8mm OD tube	BSPP Threads
A	Straight fitting for 10mm OD tube	
7	Straight fitting for 1/4 inch OD tube	NPT Threads
9	Straight fitting for 3/8 inch OD tube	

Number of stations*	
4 Valve manifold	04
8 Valve manifold	08
12 Valve manifold	12
16 Valve manifold	16
20 Valve manifold	20
24 Valve manifold	24
28 Valve manifold	28
32 Valve manifold	32

* For an Add-A-Fold part number to be valid, all stations must have a corresponding electrical connection at the end plate. See Maximum Number of Solenoids chart.

3/8" inlet port on end plate		
0	Without fitting	
8	Straight fitting for 8mm OD tube	BSPP Threads
A	Straight fitting for 10mm OD tube	
7	Straight fitting for 1/4 inch OD tube	NPT Threads
9	Straight fitting for 3/8 inch OD tube	

Note:
BSPP fittings can only be used with BSPP Manifolds.
NPT fittings can only be used with NPT Manifolds.

 Most popular.



For inventory, lead times, and kit lookup, visit www.pdnplu.com

Subbase & Manual Valves
 H Series Micro
 Moduflex Series
 H Series ISO
 Fieldbus Systems
 DX ISOMAX Series
 Valvair II Series

25-pin, D-Sub Manifolds

24 Single Solenoid Valves

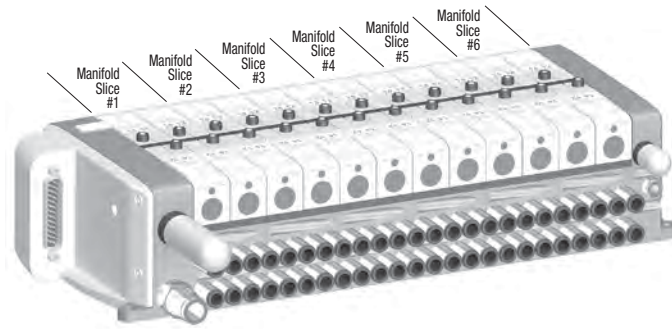

Add-A-Fold

Manifold is factory assembled and tested for pneumatic leaks and electrical continuity.

Item	Qty	Description	Part number
01	1	24 valve Add-A-Fold with end plates	AAHMD5249M0M
02	6	4 valve simple manifold slices #1-6	PSM31JAPE7E7E7E7

Component Level

Item	Qty	Description	Part number
01	1	25-pin, D-sub, end plate	PSML25AP
02	24	Single solenoid valve	HMEVX2049A
03	6	Manifold, side ported, single address	PSM21JAP
04	50	1/4" Tube fittings (in box quantity)	PS567925
05	10	3/8" Tube fittings (in box quantity)	PS568338
06	1	3/8" Exhaust muffler	P6M-PAB3
07	1	1/8" Exhaust muffler	P6M-PAB1

Sandwich Regulator

Description	Kit number
 Common port regulator, 5 to 125 PSI with gauge	PSMRAX6AP

Notes: Cv values are reduced when using a sandwich regulator to 0.20 for 2-position and Dual 3/2 valves, and 0.17 for 3-position APB valves. The sandwich regulator passes full pilot pressure from the manifold, allowing the regulated pressure to adjusted down to 5 PSI without affecting valve functionality.



Flow Controls

Description	Kit number
 4mm to 4mm or 5/32" to 5/32" OD tube	FC832-5/32
1/4" to 1/4" O.D. tube	FC832-4

 Most popular.

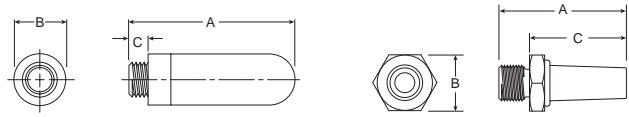
Mufflers





Port thread	A	Ø B	C	Weight (grams)	Part number
 1/8 pilot exhaust – BSPP or NPT	1.14 (29)	0.55 (14)	0.24 (6)	0.02	P6M-PAB1
 3/8 main exhaust – BSPP or NPT	2.36 (60)	0.98 (25)	0.35 (9)	0.06	P6M-PAB3
 M7 x 1 bottom port pilot exhaust *	0.98 (25)	0.43 (11)	0.75 (19)	5	P0568800

Note: Recommended tube durometer of 95 or higher. A tube support may be required if tube durometer is less than 95.

* Must be order in multiples of 10.

Fittings – Must be ordered in multiples of 10

Thread	Tube O.D.	Part number
Manifold or pilot supply ports – straight		
 M7	4mm or 5/32"	PS567904
M7	6mm	PS567906
M7	1/4"	PS567925
Main inlet or exhaust ports		
 3/8" NPT	1/4"	PS568325
3/8" NPT	3/8"	PS568338
3/8" BSPP	8mm	PS568308
3/8" BSPP	10mm	PS568310
Pilot exhaust ports		
 1/8" NPT	5/32"	PS568215
1/8" NPT	1/4"	PS568225
1/8" BSPP	4mm	PS568204
1/8" BSPP	6mm	PS568206



For inventory, lead time, and kit lookup, visit www.pdnplu.com

Moduflex Fieldbus Manifold

**4 Double Solenoid Valves,
 8 Single Solenoid Valves**

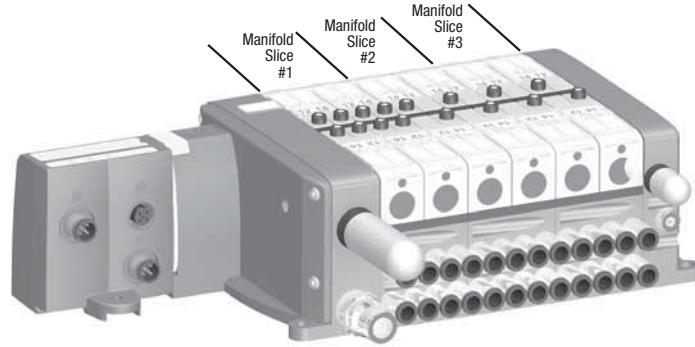

Add-A-Fold

Manifold is factory assembled and tested for pneumatic leaks and electrical continuity.

Item	Qty	Description	Part number
01	1	12 valve add-a-fold with end plates	AAHMT5129M0M
02	1	4 valve simple manifold slice #1	PSM31MAPN7N7N7
03	2	4 valve simple manifold slice #2-3	PSM31JAPE7E7E7E7

Component Level

Item	Qty	Description	Part number
01	1	Moduflex fieldbus, end plate	PSMM45AP
02	4	Double solenoid, dual 3/2, NC/NC	HMN VX2049A
03	1	Manifold, side ported, double address	PSM21MAP
04	8	Single solenoid valve	HMEVX2049A
05	2	Manifold, side ported, single address	PSM21JAP
06	30	1/4" tube fittings (in box quantity)	PS567925
05	10	3/8" tube fittings (in box quantity)	PS568338
06	1	3/8" exhaust muffler	P6M-PAB3
07	1	1/8" exhaust muffler	P6M-PAB1

Additional Components

Moduflex Communication Modules

IO-Link - 24 outputs		Part number
Class A	3-Pin, Aux power 1 & 3	P2M2HBVL12400A13
	3-Pin, Aux power 4 & 3	P2M2HBVL12400A43
	3-Pin, Aux power 4 & 2	P2M2HBVL12400A42
Class B	5-Pin, Aux power 2 & 5	P2M2HBVL12400B25
Bus protocol - 16 outputs		Part number
Profibus DP		P2M2HBVP21600
DeviceNet		P2M2HBVD21600
CANopen		P2M2HBVC21600
InterBus-S		P2M2HBVS11600

Fieldbus Accessories

	Bus Protocol	Connector Type	Part number
Power Supply Female Straight Connector	Profibus DP/ InterBus-S	M12 type A	P8CS1205AA
	DeviceNet/ CANopen	M12 type B	P8CS1205AB
Line Termination Resistor	Profibus DP	M12 type B	P8BPA00MB
	DeviceNet/ CANopen	M12 type A	P8BPA00MA
Power & Communication Cable	IO-Link	5-pin male to female cable, TPE	RKC 4.5T*-RSC 4.5T/S1587

Where * = 1, 2, 3, 4, 5, 10, 20 meter standard lengths

 Most popular.

Standard AS-i Protocol (up to 31 nodes)

Communication module for 8 solenoids max. (2 nodes per module, 4 inputs, 4 solenoids per node)

Input / output capability	Part number
0 inputs and 8 solenoid outputs	P2M2HBVA10800
8 (PNP) inputs on eight (M8) connectors and 8 solenoid outputs	P2M2HBVA10808A
8 (PNP) inputs on four (M12) connectors and 8 solenoid outputs	P2M2HBVA10808B

AS-i Version 2.1 Protocol (up to 62 nodes)

Communication module for 6 solenoids max. (2 nodes per module, 4 inputs, 4 solenoids per node)

Input / output capability	Part number
0 inputs and 6 solenoid outputs	P2M2HBVA20600
8 (PNP) inputs on eight (M8) connectors and 6 solenoid outputs	P2M2HBVA20608A
8 (PNP) inputs on four (M12) connectors and 6 solenoid outputs	P2M2HBVA20608B

AS-i Bus Accessories

M12 cable with jack for addressing

Length	Part number
1 m	P8LS12JACK

D
 Subbase & Manual Valves
 H Series Micro
 Moduflex Series
 H Series ISO
 Fieldbus Systems
 DX ISOMAX Series
 Valvair II Series



For inventory, lead times, and kit lookup, visit www.pdnplu.com

H Series Fieldbus Manifold

12 Double Solenoid Valves, 8 Single Solenoid Valves

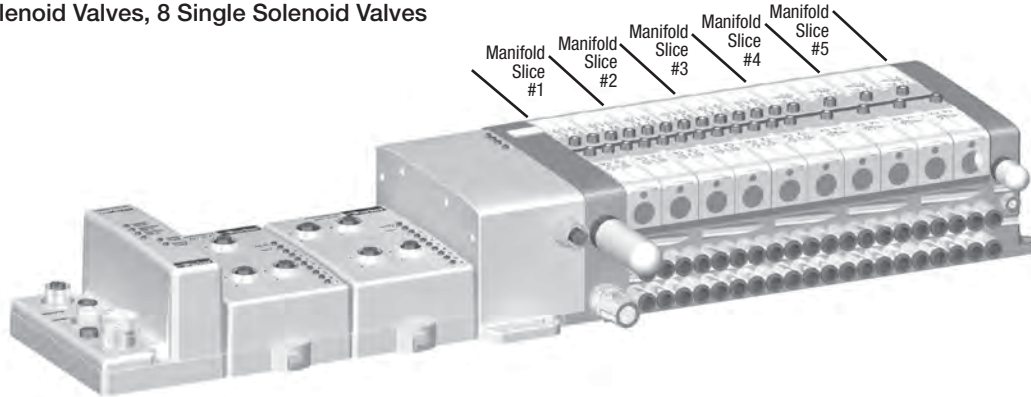

Add-A-Fold

Manifold is factory assembled and tested for pneumatic leaks and electrical continuity.

Item	Qty	Description	Part number
01	1	20 valve add-a-fold with end plates	AAHMW5209M0M
02	3	4 valve simple manifold slices #1-3	PSM31MAPN7N7N7N7
03	2	4 valve simple manifold slices #4-5	PSM31JAPE7E7E7E7

Component Level

Item	Qty	Description	Part number
01	1	H Series Fieldbus, with valve driver module and bus extension connector	PSMM55AP
02	12	Double solenoid, dual 3/2, NC/NC	HMNVX2049A
03	3	Manifold, side ported, double address	PSM21MAP
04	8	Single solenoid, 2-position, air return, spring assist	HMEVX2049A
05	2	Manifold, side ported, single address	PSM21JAP
06	40	1/4" tube fittings (in box quantity)	PS567925
07	10	3/8" tube fittings (in box quantity)	PS568338
08	1	3/8" exhaust muffler	P6M-PAB3
09	1	1/8" exhaust muffler	P6M-PAB1

12 Double Solenoid Valves, 8 Single Solenoid Valves

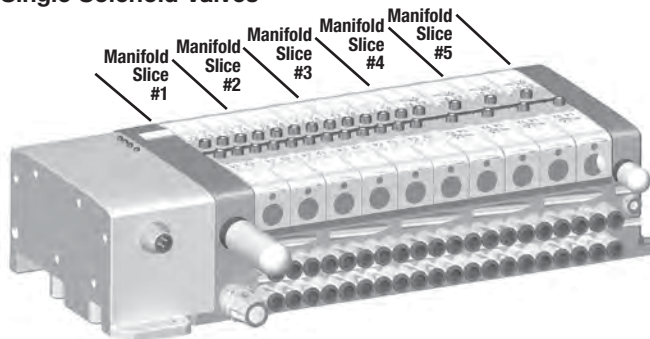

Add-A-Fold

Manifold is factory assembled and tested for pneumatic leaks and electrical continuity.

Item	Qty	Description	Part number
01	1	20 valve add-a-fold with end plates	AAHMX5209M0M
02	3	4 valve simple manifold slices #1-3	PSM31MAPN7N7N7N7
03	2	4 valve simple manifold slices #4-5	PSM31JAPE7E7E7E7

Additional Components

Description	Part number
H Series Fieldbus Devicenet Communication	PSSCDM12A
8 Digital Input, 24VDC, M12 Connectors	PSSN8M12A
H Series Micro Bus Extender Cable	PSSVEXT1

See H Series Fieldbus section of catalog for more information.

 Most popular.

D

Subbase & Manual Valves

H Series Micro

Modulflex Series

H Series ISO

Fieldbus Systems

DX ISOMAX Series





Valvair II Series



For inventory, lead time, and kit lookup, visit www.pdnplu.com

Accessories

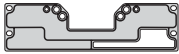
Manifold to Manifold Gaskets*

	Description	Part number
	All galleys passing	PSM0001
	Main pressure to rear or front valves blocked, exhaust passing	PSM0002
	Main pressure to rear or front valves blocked, exhaust blocked	PSM0003
	All galleys blocked	PSM0004

* Includes 1 Gasket

Solenoid Kit

Description	Part number
 24VDC solenoid kit with screws	PSM0010

Blanking Plate Kits

Description	Part number
 Blanking plugs, gasket, and mounting screws.	HMBVX00XXA

Blanking plugs must be inserted into the 2 and 4 ports of the manifold corresponding to the blanking plate.

Intermediate Air Supply Base

Description	Part number
 Gasket and mounting screws.	HMCVX00XXA

Fittings (not included) must be inserted into the 2 and 4 ports of the manifold corresponding to the intermediate air supply. Auxiliary pressure should be supplied through these fittings, which will directly feed the #1 pressure galley.

Override Caps

Description	Part number
 Set of 10 manual override caps	PSM0011

Gaskets and Valve Screws

Description	Part number
 Set of 5 valve to manifold gaskets and 10 screws	PSM0012

Regulator Gauge

Description	Part number
 5 to 125 PSI gauge	P0566202

**Subbase & Manifold Valve Products
H Series Micro**

Plugs

Description	Part number
 Set of 10 M7 plugs (Part No. PS567900) for auxiliary and pilot pressure ports	PSM0013

Screws

Description	Part number
 Set of 10 manifold to manifold M3 screws	PSM0014

Valve Labels*

Description	Part number
Single solenoid diagram	PSM002E
Double solenoid diagram	PSM0022
Double solenoid diagram – APB	PSM0025
Double solenoid diagram – Dual 3/2 NC/NC	PSM002N
Double solenoid diagram – Dual 3/2 NO/NO	PSM002P
Double solenoid diagram – Dual 3/2, 14 end NO, 12 end NC	PSM002Q

*Includes 10 Labels.

Protective Cover

Description	Part number
 Protective polyester cover Set of 10	PS5706

25-Pin, D-Sub Cable (Female)

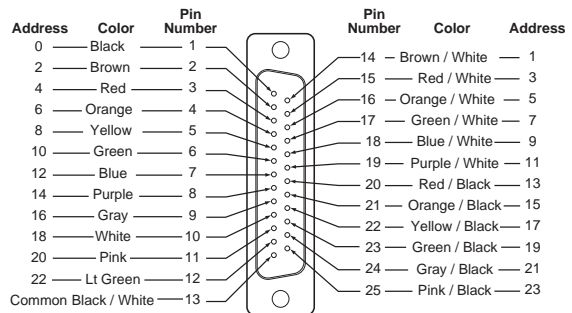

Description	Length	Part number
 25-pin, D-sub cable, IP20	3 meters	P8LMH25M3A
25-pin, D-sub cable, IP20	9 meters	SCD259D
25-pin, D-sub cable, IP65	3 meters	SCD253W
25-pin, D-sub cable, IP65	9 meters	SCD259WE

D

Subbase & Manual Valves

H Series Micro

Modulflex Series

H Series ISO

Fieldbus Systems

DX ISOMAX Series

Valvair II Series



For inventory, lead times, and kit lookup, visit www.pdnplu.com

Pilot Configuration

Side Ported

Manifolds can be configured for either internal or external pilot in the field. Side ported manifolds are configured for internal pilot when the M7 plug is located in the Px port on the front of the right hand end plate. Moving this plug to the internal pilot port of the right hand end plate and replacing it with a fitting allows an external pilot to be used.

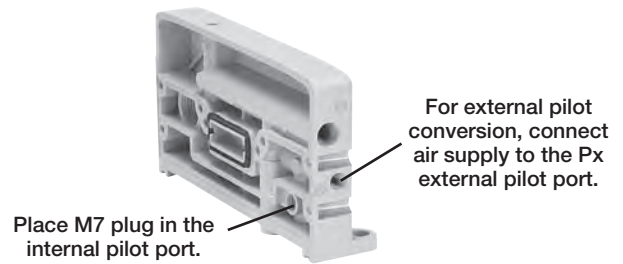

Bottom Ported

Bottom ported manifolds are configured for internal pilot when the M7 plug is located in the Px port on the bottom of the right hand end plate. Moving this plug to the internal pilot port of the right hand end plate and replacing it with a fitting allows an external pilot to be used.

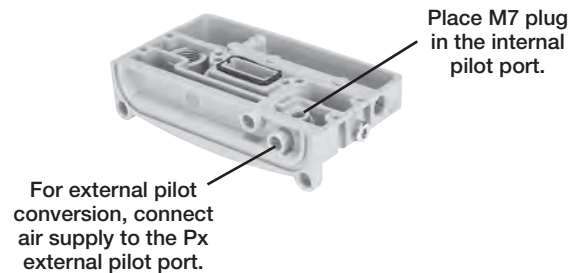

Pilot Pressure Requirements

Internal pilot pressure is supplied to the entire manifold from the right hand end plate, where the main pressure for the front row of valves is connected to the pilot pressure galley.

Maximum pilot pressure is 120 PSI. For applications requiring working pressures from 120 to 145 PSI, an external pilot supply less than 120 PSI is required.

Valve number	Minimum pilot pressure	Maximum pilot pressure
HMEVX2049A	40 PSI	120 PSI
HM2VX2049A	25 PSI	120 PSI
HM5VX2049A	45 PSI	120 PSI
HMNVX2049A	40 PSI	120 PSI
HMPVX2049A	40 PSI	120 PSI
HMQVX2049A	40 PSI	120 PSI

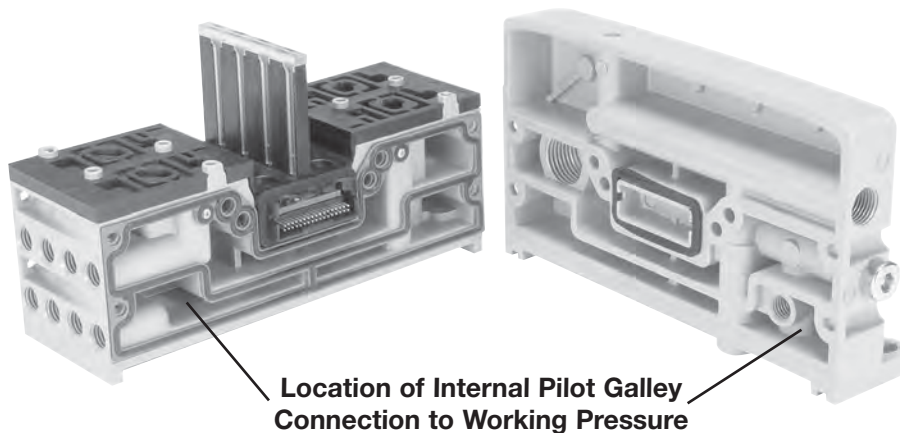

D

Subbase & Manual Valves

H Series Micro

Moduflex Series

H Series ISO

Fieldbus Systems

DX ISOMAX Series

Valvair II Series



For inventory, lead time, and kit lookup, visit www.pdnplu.com

Single Solenoid - Single Address Manifolds

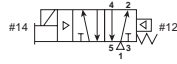

Single Pressure At Inlet Port 1:

De-energized position – Solenoid operator #14 de-energized. Pressure at inlet port 1 connected to outlet port 2. Outlet port 4 connected to exhaust port 5.

Energized position – Solenoid operator #14 energized. Pressure at inlet port 1 connected to outlet port 4. Outlet port 2 connected to exhaust port 3.

HMEVX2049A - Single Address Manifolds

Valve Position A		Valve Position C	
Output 0		Output 2	
On	Off	On	Off
1→4	1→2	1→4	1→2
3←2	5←4	3←2	5←4

Valve Position B		Valve Position D	
Output 1		Output 3	
On	Off	On	Off
1→4	1→2	1→4	1→2
3←2	5←4	3←2	5←4

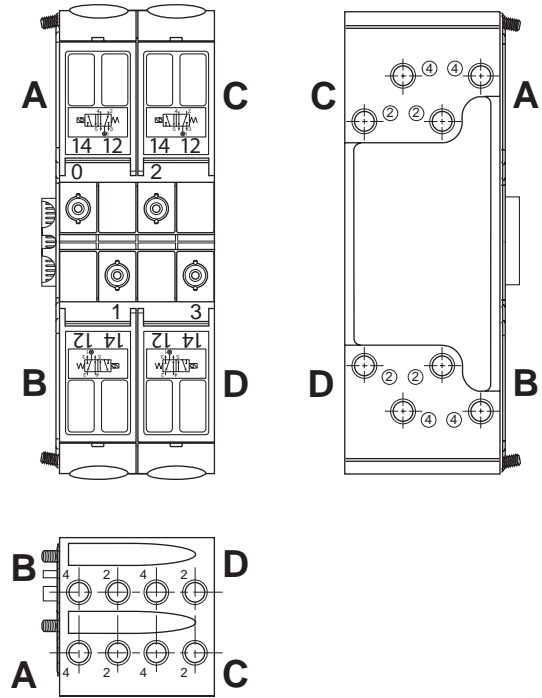

Single Solenoid - Double Address Manifolds

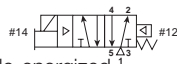

Single Pressure At Inlet Port 1:

De-energized position – Solenoid operator #14 de-energized. Pressure at inlet port 1 connected to outlet port 2. Outlet port 4 connected to exhaust port 5.

Energized position – Solenoid operator #14 energized. Pressure at inlet port 1 connected to outlet port 4. Outlet port 2 connected to exhaust port 3.

HMEVX2049A - Double Address Manifolds

Valve Position A				Valve Position C			
Output 0		Output 1		Output 4		Output 5	
On	Off	On	Off	On	Off	On	Off
1→4	1→2	Output Lost		1→4	1→2	Output Lost	
3←2	5←4	1→2	1→2	3←2	5←4	1→2	1→2
		5←4	5←4			5←4	5←4

Valve Position B				Valve Position D			
Output 3		Output 2		Output 7		Output 6	
On	Off	On	Off	On	Off	On	Off
Output Lost				1→4	1→2	Output Lost	
1→2	1→2	3←2	5←4	1→4	1→2	3←2	5←4
5←4	5←4			5←4	5←4		

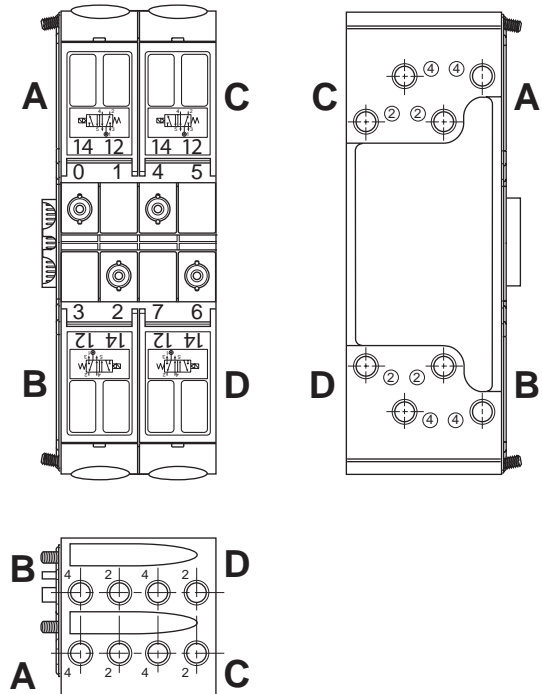

D
 Subbase & Manual Valves
 H Series Micro
 Modulflex Series
 H Series ISO
 Fieldbus Systems
 DX ISOMAX Series
 Valvair II Series



For inventory, lead times, and kit lookup, visit www.pdnplu.com

Double Solenoid - Double Address Manifolds, Last state #12 Energized or #14 Energized

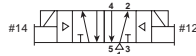

Single Pressure At Inlet Port 1:

Solenoid operator #14 energized last. Pressure at inlet port 1 connected to outlet port 4. Outlet port 2 connected to exhaust port 3.

Solenoid operator #12 energized last. Pressure at inlet port 1 connected to outlet port 2. Outlet port 4 connected to exhaust port 5.

A 2-Position, Double Solenoid Valve is a detented valve. When the output is removed, the spool remains in its position.

HM2VX2049A - Double Address Manifolds - Last state #12 Energized

Valve Position A				Valve Position C			
Output 0		Output 1		Output 4		Output 5	
On	Off	On	Off	On	Off	On	Off
1→4	1→2	1→2	1→2	1→4	1→2	1→2	1→2
3←2	5←4	5←4	5←4	3←2	5←4	5←4	5←4

Valve Position B				Valve Position D			
Output 3		Output 2		Output 7		Output 6	
On	Off	On	Off	On	Off	On	Off
1→2	1→2	1→4	1→2	1→2	1→2	1→4	1→2
5←4	5←4	3←2	5←4	5←4	5←4	3←2	5←4

HM2VX2049A - Double Address Manifolds - Last state #14 Energized

Valve Position A				Valve Position C			
Output 0		Output 1		Output 4		Output 5	
On	Off	On	Off	On	Off	On	Off
1→4	1→4	1→2	1→4	1→4	1→4	1→2	1→4
3←2	3←2	5←4	3←2	3←2	3←2	5←4	3←2

Valve Position B				Valve Position D			
Output 3		Output 2		Output 7		Output 6	
On	Off	On	Off	On	Off	On	Off
1→2	1→4	1→4	1→4	1→2	1→4	1→4	1→4
5←4	3←2	3←2	3←2	5←4	3←2	3←2	3←2

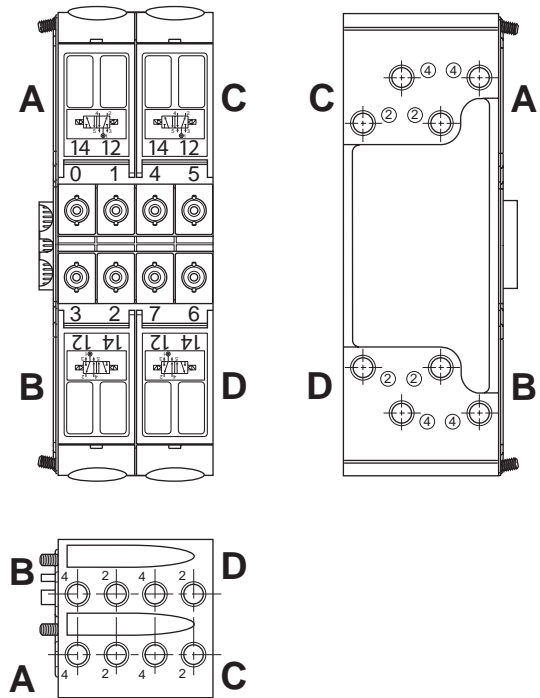

Double Solenoid - Double Address Manifolds

Dual 3-Way, 2-Position NC / NC (NNP)

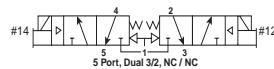

With #14 & #12 operators both de-energized – pressure at inlet port 1 blocked, outlet port 4 connected to exhaust port 5, outlet port 2 connected to exhaust port 3.

With #14 operator energized – pressure at inlet port 1 connected to outlet port 4, exhaust port 5 blocked, outlet port 2 connected to exhaust port 3.

With #12 operator energized – pressure at inlet port 1 connected to outlet port 2, exhaust port 3 blocked, outlet port 4 connected to exhaust port 5.

With #14 & #12 operators both energized – pressure at inlet port 1 connected to outlet ports 4 & 2, exhaust ports 3 & 5 blocked.

HMNVX2049A - Double Address Manifolds

Valve Position A				Valve Position C			
Output 0		Output 1		Output 4		Output 5	
On	Off	On	Off	On	Off	On	Off
1→2	1→	1→4	1→	1→2	1→	1→4	1→
3→	3←2	5→	5←4	3→	3←2	5→	5←4

Valve Position B				Valve Position D			
Output 3		Output 2		Output 7		Output 6	
On	Off	On	Off	On	Off	On	Off
1→4	1→	1→2	1→	1→4	1→	1→2	1→
5→	5←4	3→	3←2	5→	5←4	3→	3←2

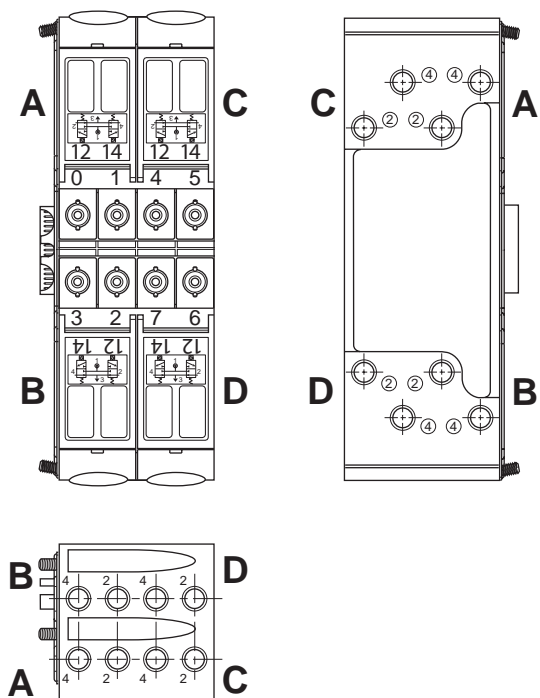

For inventory, lead time, and kit lookup, visit www.pdnplu.com

Double Solenoid - Double Address Manifolds

**Dual 3-Way, 2-Position
 NO / NO (NP)**

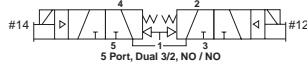

With #14 & #12 operators both de-energized – pressure at inlet port 1 connected to outlet ports 4 & 2, exhaust ports 3 & 5 blocked.

With #14 operator energized – pressure at inlet port 1 connected to outlet port 2, exhaust port 3 blocked, outlet port 4 connected to exhaust port 5.

With #12 operator energized – pressure at inlet port 1 connected to outlet port 4, exhaust port 5 blocked, outlet port 2 connected to exhaust port 3.

With #14 & #12 operators both energized – pressure at inlet port 1 blocked, outlet port 4 connected to exhaust port 5, outlet port 2 connected to exhaust port 3.

HMPVX2049A - Double Address Manifolds

Valve Position A				Valve Position C			
Output 0		Output 1		Output 4		Output 5	
On	Off	On	Off	On	Off	On	Off
1→	1→2	1→	1→4	1→	1→2	1→	1→4
3←2	3→	5←4	5→	3←2	3→	5←4	5→

Valve Position B				Valve Position D			
Output 3		Output 2		Output 7		Output 6	
On	Off	On	Off	On	Off	On	Off
1→	1→4	1→	1→2	1→	1→4	1→	1→2
5←4	5→	3←2	3→	5←4	5→	3←2	3→

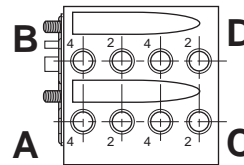
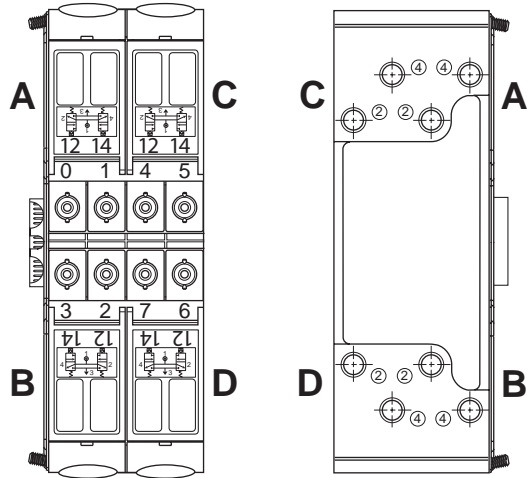

Double Solenoid - Double Address Manifolds

**Dual 3-Way, 2-Position
 14 End NO / 12 End NC
 (NP / NNP)**

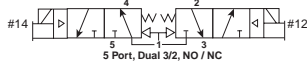

With #14 & #12 operators both de-energized – pressure at inlet port 1 connected to outlet port 4, exhaust port 5 blocked, outlet port 2 connected to exhaust port 3.

With #14 operator energized – pressure at inlet port 1 blocked, outlet port 4 connected to exhaust port 5, outlet port 2 connected to exhaust port 3.

With #12 operator energized – pressure at inlet port 1 connected to outlet ports 4 & 2, exhaust ports 3 & 5 blocked.

With #14 & #12 operators both energized – pressure at inlet port 1 connected to outlet port 2, exhaust port 3 blocked, outlet port 4 connected to exhaust port 5.

HMQVX2049A - Double Address Manifolds

Valve Position A				Valve Position C			
Output 0		Output 1		Output 4		Output 5	
On	Off	On	Off	On	Off	On	Off
1→2	1→	1→	1→4	1→2	1→	1→	1→4
3→	3←2	5←4	5→	3→	3←2	5←4	5→

Valve Position B				Valve Position D			
Output 3		Output 2		Output 7		Output 6	
On	Off	On	Off	On	Off	On	Off
1→	1→4	1→2	1→	1→	1→4	1→2	1→
5←4	5→	3→	3←2	5←4	5→	3→	3←2

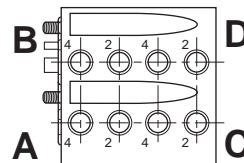
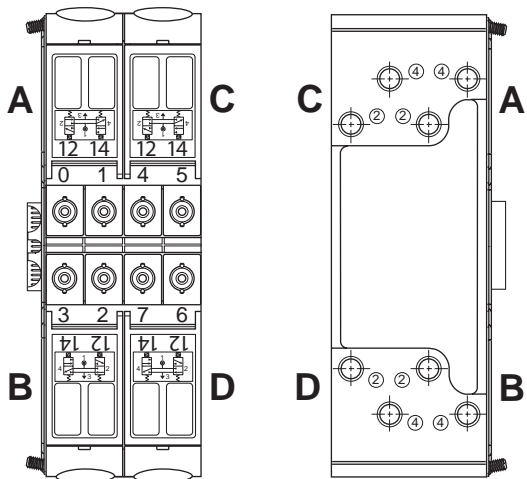

D

Subbase & Manual
 Valves

H Series
 Micro

Modulflex
 Series

H Series
 ISO

Fieldbus
 Systems

DX ISOMAX
 Series

Valvair II
 Series



For inventory, lead times, and kit lookup, visit www.pdnplu.com

Double Solenoid - Double Address Manifolds

3-Position

Function 5: All Ports Blocked

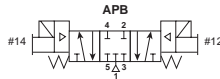

With #12 operator energized – inlet port 1 connected to cylinder port 2, cylinder port 4 connected to exhaust port 5.

With #14 operator energized – inlet port 1 connected to cylinder port 4, cylinder port 2 connected to exhaust port 3.

All ports blocked in the center position.

HM5VX2049A - Double Address Manifolds

Valve Position A			Valve Position C		
Output 0 On	Output 0 Off	Output 0 Off	Output 4 On	Output 4 Off	Output 4 Off
Output 1 Off	Output 1 On	Output 1 Off	Output 5 Off	Output 5 On	Output 5 Off
5→1	5←4	3→1 1→4	5→1	5←4	3→1 1→4
1→4	1→2	1→1 1→2	1→4	1→2	1→1 1→2
3→2	3→1	5→1	3→2	3→1	5→1

Valve Position B			Valve Position D		
Output 2 On	Output 2 Off	Output 2 Off	Output 6 On	Output 6 Off	Output 6 Off
Output 3 Off	Output 3 On	Output 3 Off	Output 7 Off	Output 7 On	Output 7 Off
5→1	5←4	3→1 1→4	5→1	5←4	3→1 1→4
1→4	1→2	1→1 1→2	1→4	1→2	1→1 1→2
3→2	3→1	5→1	3→2	3→1	5→1

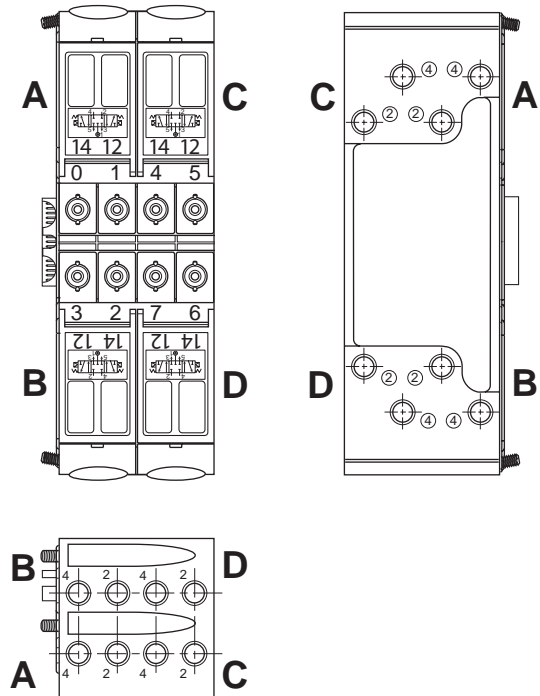

Dual 3/2 valves replace 3-position valves for better performance

3-position center exhaust

A traditional 5/3 center exhaust valve is now replaced by a double 3/2 NC+NC valve module. Both cylinder chambers are exhausted and rod and piston are free to move.

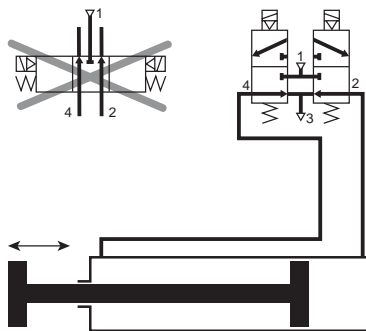

3-position pressure center

A traditional 5/3 pressure center valve is now replaced by a double 3/2 NO+NO valve module. The function is identical.

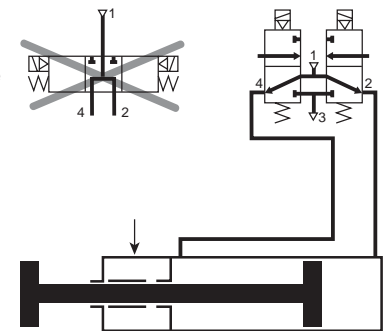

For inventory, lead time, and kit lookup, visit www.pdnplu.com

Multiple Pressure Zones

PSM0001 –

All ports open. Common pressure for front and rear manifold.
 Common exhausts.
 Standard gasket included with each manifold and end plate.

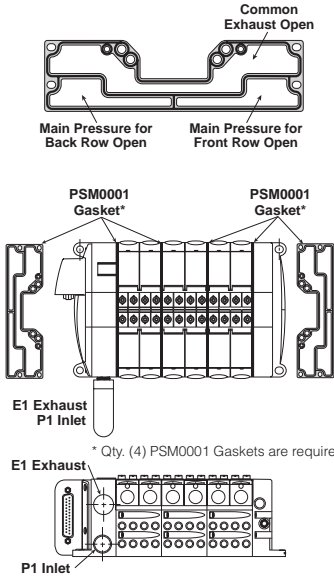

PSM0002 –

Rear manifold blocked for separate pressure supply.
 Common exhausts.
 Flip gasket to block front of manifold.

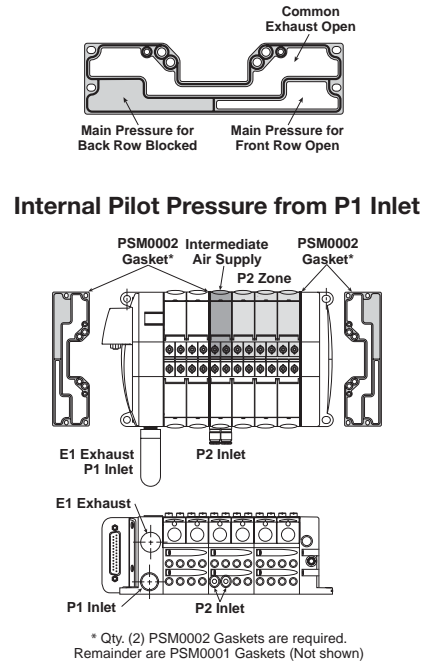

PSM0003 –

Rear manifold blocked for separate pressure supply.
 Exhaust blocked also.
 Flip gasket to block front of manifold.
 If used with bottom ported end plates, second exhaust must be piped from the side of the right end plate.

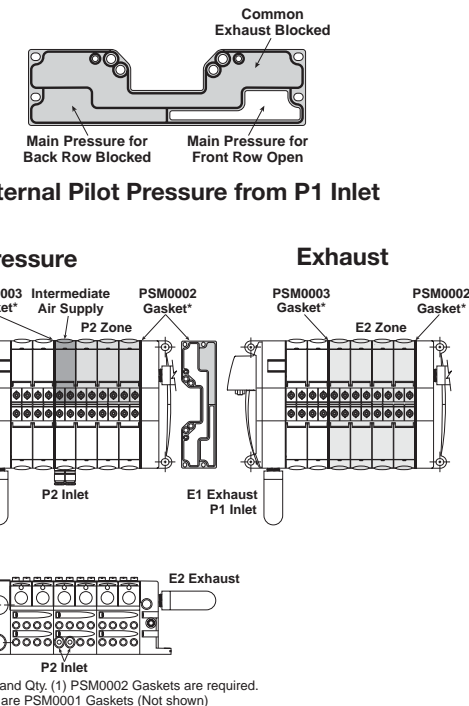

PSM0004 –

All galleys blocked.
 Two pressure zones and two exhaust zones.
 If used with bottom ported end plates, second exhaust must be piped from the side of the right end plate.

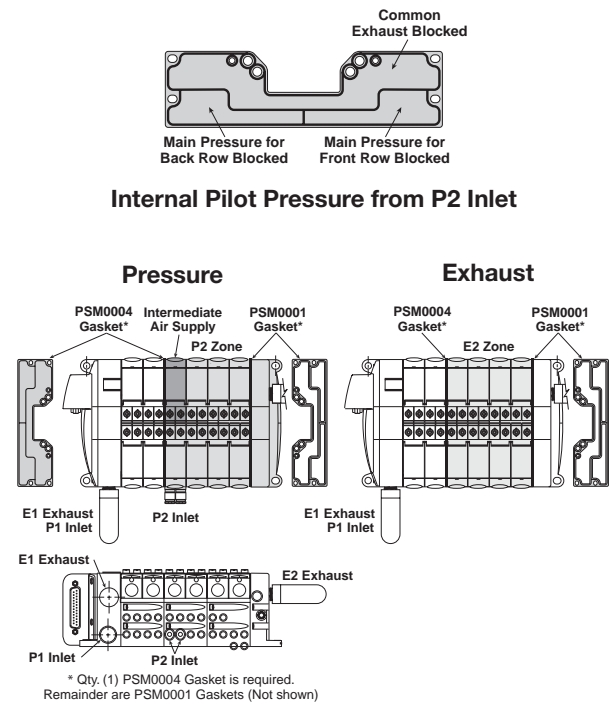

D
 Subbase & Manual Valves
 H Series Micro
 Modulflex Series
 H Series ISO
 Fieldbus Systems
 DX ISOMAX Series
 Valvair II Series



For inventory, lead times, and kit lookup, visit www.pdnplu.com

Maximum Number of Solenoids

(Maximum Energized Simultaneously)

	25-Pin D-Sub	Moduflex	H Series Fieldbus*
24VDC	24 (24)	24 (24)	32 (32)

* Maximum of 32 solenoids per manifold. With Bus Extension functionality, 4 manifolds with up to 32 solenoids each can be connected on the same network.

25-Pin, D-Sub Connector (Male)

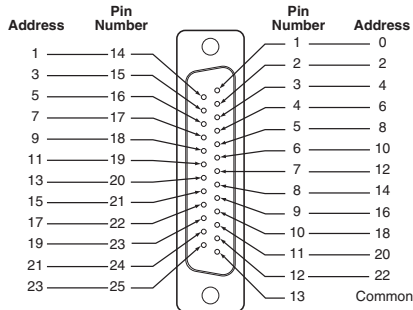

View into End Plate Connector - Male D-Sub, 25-Pin

**Single Solenoid Valves Shown
Solenoid is De-energized**

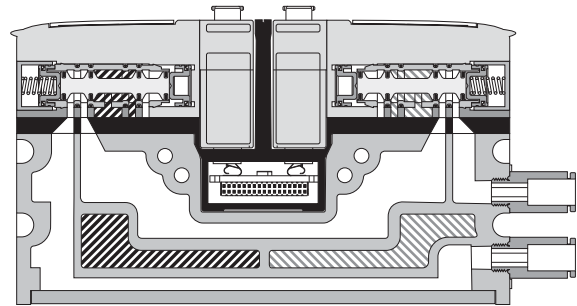

Side Exhaust
4 Ports Connected to Exhaust Port
(5 & 3 Common)

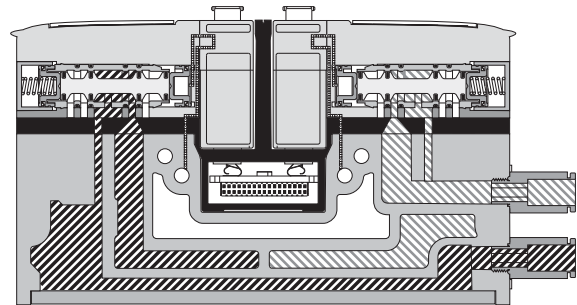

Side Pressure
2 Ports Connected to Inlet Port 1



D

Subbase & Manual Valves

H Series Micro

Moduflex Series

H Series ISO

Fieldbus Systems

DX ISOMAX Series

Valvair II Series



For inventory, lead time, and kit lookup, visit www.pdnplu.com

Cv Values - H Series Micro

The charts below represent the minimum required Cv values for pneumatic systems operating at 80 PSI with a 5 PSI pressure drop.

To use the chart, locate the diameter of the cylinder across the horizontal axis, then the average required rod speed of the cycle. The intersection point is Cv value needed.

Grayed out values are not attainable with H Series Micro. Please select a larger Parker valve.

Average Rod Speed (mm/s)	Cylinder Diameter (mm)												
	6	8	10	12	16	20	25	32	40	50	63	80	100
25	0.000	0.001	0.001	0.002	0.003	0.005	0.008	0.013	0.021	0.032	0.051	0.083	0.129
50	0.001	0.002	0.003	0.004	0.007	0.010	0.016	0.026	0.041	0.065	0.103	0.166	0.259
75	0.001	0.002	0.004	0.006	0.010	0.016	0.024	0.040	0.062	0.097	0.154	0.248	0.388
100	0.002	0.003	0.005	0.007	0.013	0.021	0.032	0.053	0.083	0.129	0.205	0.331	0.517
125	0.002	0.004	0.006	0.009	0.017	0.026	0.040	0.066	0.103	0.162	0.257	0.414	0.647
150	0.003	0.005	0.008	0.011	0.020	0.031	0.049	0.079	0.124	0.194	0.308	0.497	0.776
175	0.003	0.006	0.009	0.013	0.023	0.036	0.057	0.093	0.145	0.226	0.359	0.580	0.906
200	0.004	0.007	0.010	0.015	0.026	0.041	0.065	0.106	0.166	0.259	0.411	0.662	1.035
225	0.004	0.007	0.012	0.017	0.030	0.047	0.073	0.119	0.186	0.291	0.462	0.745	1.164
250	0.005	0.008	0.013	0.019	0.033	0.052	0.081	0.132	0.207	0.323	0.513	0.828	1.294
275	0.005	0.009	0.014	0.020	0.036	0.057	0.089	0.146	0.228	0.356	0.565	0.911	1.423
300	0.006	0.010	0.016	0.022	0.040	0.062	0.097	0.159	0.248	0.388	0.616	0.994	1.552
350	0.007	0.012	0.018	0.026	0.046	0.072	0.113	0.185	0.290	0.453	0.719	1.159	1.811
400	0.007	0.013	0.021	0.030	0.053	0.083	0.129	0.212	0.331	0.517	0.822	1.325	2.070
450	0.008	0.015	0.023	0.034	0.060	0.093	0.146	0.238	0.373	0.582	0.924	1.490	2.329
500	0.009	0.017	0.026	0.037	0.066	0.103	0.162	0.265	0.414	0.647	1.027	1.656	2.587

Average Rod Speed (in/s)	Cylinder Diameter (in)																
	5/16"	7/16"	9/16"	3/4"	7/8"	1"	1-1/16"	1-1/8"	1-1/4"	1-1/2"	1-3/4"	2"	2-1/2"	3"	3-1/4"	3-5/8"	4"
1	0.001	0.002	0.003	0.005	0.006	0.008	0.010	0.011	0.013	0.019	0.026	0.034	0.053	0.076	0.090	0.111	0.136
2	0.002	0.003	0.005	0.010	0.013	0.017	0.019	0.021	0.026	0.038	0.052	0.068	0.106	0.153	0.179	0.223	0.271
3	0.002	0.005	0.008	0.014	0.019	0.025	0.029	0.032	0.040	0.057	0.078	0.102	0.159	0.229	0.269	0.334	0.407
4	0.003	0.006	0.011	0.019	0.026	0.034	0.038	0.043	0.053	0.076	0.104	0.136	0.212	0.305	0.358	0.446	0.543
5	0.004	0.008	0.013	0.024	0.032	0.042	0.048	0.054	0.066	0.095	0.130	0.170	0.265	0.382	0.448	0.557	0.678
6	0.005	0.010	0.016	0.029	0.039	0.051	0.057	0.064	0.079	0.114	0.156	0.204	0.318	0.458	0.537	0.669	0.814
7	0.006	0.011	0.019	0.033	0.045	0.059	0.067	0.075	0.093	0.134	0.182	0.237	0.371	0.534	0.627	0.780	0.950
8	0.007	0.013	0.021	0.038	0.052	0.068	0.077	0.086	0.106	0.153	0.208	0.271	0.424	0.611	0.717	0.891	1.085
9	0.007	0.015	0.024	0.043	0.058	0.076	0.086	0.097	0.119	0.172	0.234	0.305	0.477	0.687	0.806	1.003	1.221
10	0.008	0.016	0.027	0.048	0.065	0.085	0.096	0.107	0.132	0.191	0.260	0.339	0.530	0.763	0.896	1.114	1.357
11	0.009	0.018	0.030	0.052	0.071	0.093	0.105	0.118	0.146	0.210	0.286	0.373	0.583	0.839	0.985	1.226	1.492
12	0.010	0.019	0.032	0.057	0.078	0.102	0.115	0.129	0.159	0.229	0.312	0.407	0.636	0.916	1.075	1.337	1.628
14	0.012	0.023	0.038	0.067	0.091	0.119	0.134	0.150	0.185	0.267	0.364	0.475	0.742	1.068	1.254	1.560	1.899
16	0.013	0.026	0.043	0.076	0.104	0.136	0.153	0.172	0.212	0.305	0.415	0.543	0.848	1.221	1.433	1.783	2.171
18	0.015	0.029	0.048	0.086	0.117	0.153	0.172	0.193	0.238	0.343	0.467	0.611	0.954	1.374	1.612	2.006	2.442
20	0.017	0.032	0.054	0.095	0.130	0.170	0.191	0.215	0.265	0.382	0.519	0.678	1.060	1.526	1.791	2.229	2.713

D
 Subbase & Manual Valves
 H Series Micro
 Moduteflex Series
 H Series ISO
 Fieldbus Systems
 DX ISOMAX Series
 Valvair II Series



For inventory, lead times, and kit lookup, visit www.pdnplu.com

Flow Characteristics

Dual 3/2

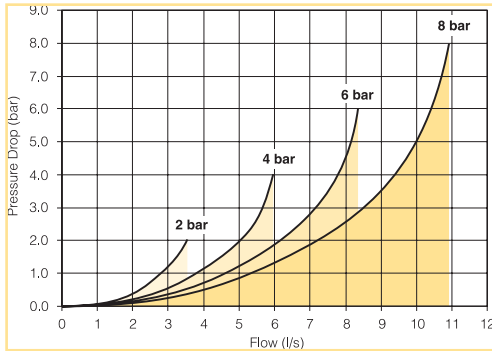

Operating pressure: 39 to 120.3 PSI (2.7 to 8.3 bar)
 Change-over time (side 14): Actuation 15 ms
 Return 20 ms P = 6b
 Change-over time (side 12): 15 ms / 25 ms P = 6b
 Flow (acc. to ISO 6358): c = 1.2 NI/s x bar
 b = 0.13
 Qn = 4.6 NI/s
 Qmax = 8.4 NI/s

5/2 single and double solenoid

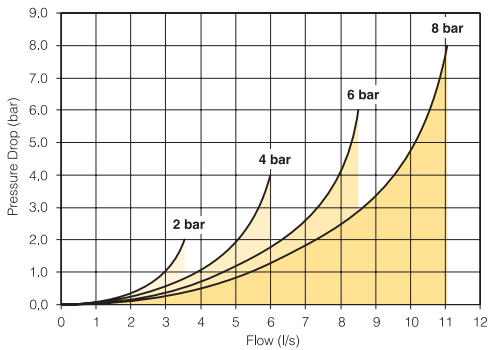

Operating pressure: Single solenoid 39 to 120.3 PSI (2.7 to 8.3 bar)
 Double solenoid 24.6 to 120.3 PSI (1.7 to 8.3 bar)
 Change-over time: Single solenoid Actuation 15 ms
 Return 20 ms P = 6b
 Double solenoid 13 ms / 13 ms P = 6b
 Flow (acc. to ISO 6358): c = 1.2 NI/s x bar
 b = 0.13
 Qn = 4.7 NI/s
 Qmax = 8.5 NI/s

5/3 all ports blocked

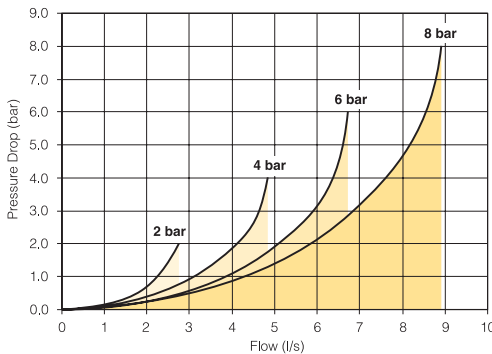

Operating pressure: 39 to 120.3 PSI (2.7 to 8.3 bar)
 Change-over time: Actuation 20 ms
 Return 20 ms P = 6b
 Flow (acc. to ISO 6358): c = 1 NI/s x bar
 b = 0.14
 Qn = 3.8 NI/s
 Qmax = 6.7 NI/s

Characteristics

Fluid: Air or inert gas
 Filtered 40 μ
 Class 5 (according to ISO 8573-1)
 Dry class 4 (according to ISO 8573-1)
 Non-lubricated or lubricated
 Storage temperature: 104°F to 158°F (-40°C to 70°C)
 Working temperature: 5°F to 122°F (-15°C to 50°C)
 Vibration: according to IEC 68-2-6
 2G to 150 Hz
 Shock: according to IEC 68-2-27
 15G 11 ms

Operating pressure: -13 to 120.3 PSI (-0.9 to 8.3 bar)
 with external pressure 87 PSI (6 bar)
 Piloting pressure: 37 to 120.3 PSI (2.7 to 8.3 bar)
 Exhaust collection: Independent exhaust collection
 Rated coil voltage: 24 VDC -15 % / +10 %
 Electrical connection: Not polarized
 Coil insulation: Class B
 Power consumption: 1 W (42 mA) with LED
 Duty factor: 100 % at 68°F (20°C)



For inventory, lead time, and kit lookup, visit www.pdnplu.com

D21

Parker Hannifin Corporation
 Pneumatic Division
 Richland, Michigan
www.parker.com/pneumatics

D

Subbase & Manual Valves

H Series Micro

Moduflex Series

H Series ISO

Fieldbus Systems

DX ISOMAX Series

Valvair II Series

25-pin, D-Sub with H Series Micro Valves, Side Ported

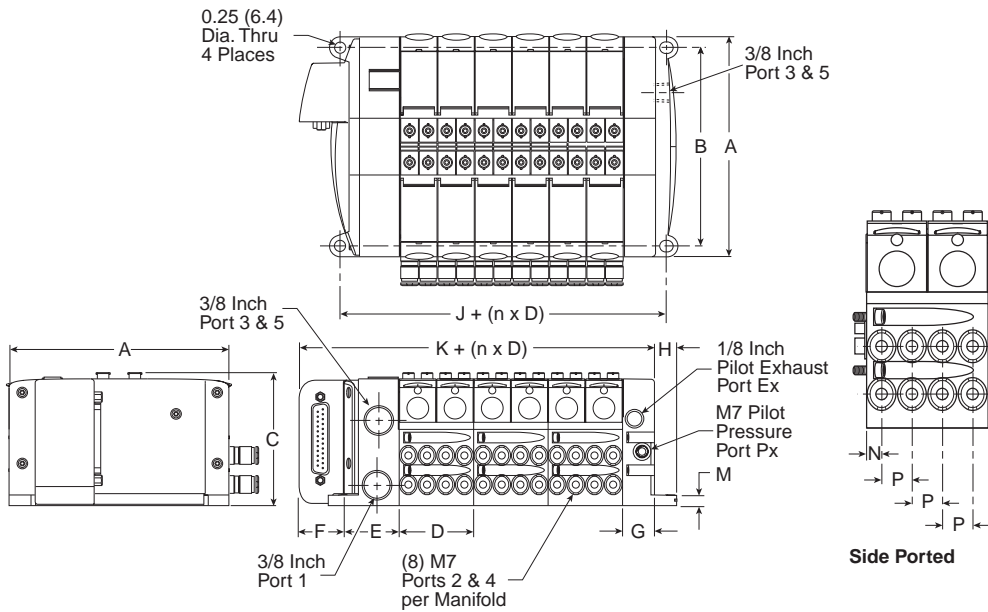

Dimensions

A	B	C	D
4.88	4.41	2.95	1.65
(124.0)	(112.0)	(75.0)	(42.0)

E	F	G	H
1.22	1.02	0.71	0.49
(31.0)	(26.0)	(18.0)	(12.5)

J	K	M	N
2.28	3.44	0.24	0.21
(58.0)	(87.5)	(6.1)	(5.2)

P
0.41
(10.5)

Inches (mm)
 n = Number of manifolds

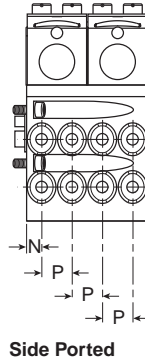

Side Ported

25-pin, D-Sub with H Series Micro Valves, Bottom Ported

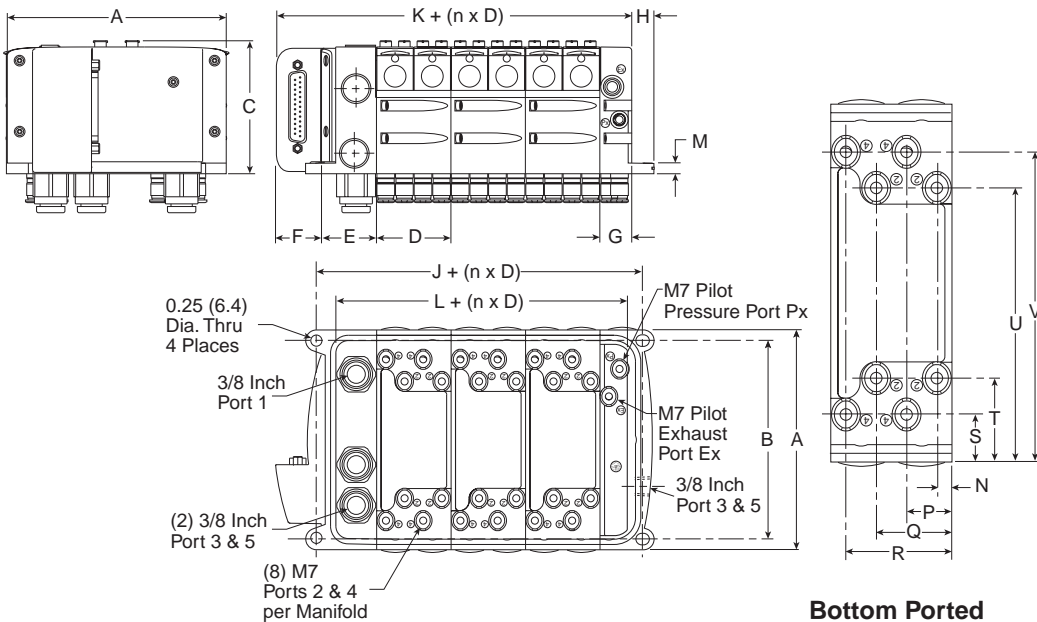

Dimensions

A	B	C	D
4.88	4.41	2.95	1.65
(124.0)	(112.0)	(75.0)	(42.0)

E	F	G	H
1.22	1.02	0.71	0.49
(31.0)	(26.0)	(18.0)	(12.5)

J	K	L	M
2.28	3.44	1.69	0.24
(58.0)	(87.5)	(43.0)	(6.1)

N	P	Q	R
0.21	0.62	1.03	1.45
(5.3)	(15.8)	(26.3)	(36.8)

S	T	U	V
0.64	1.14	3.73	4.23
(16.40)	(29.0)	(94.9)	(107.4)

Inches (mm)
 n = Number of manifolds

Bottom Ported Detail

Note:
 See Fieldbus Section for the dimensions of manifolds utilizing the H Series Fieldbus, Turck, or Modflex end plate type.



For inventory, lead times, and kit lookup, visit www.pdnplu.com

D22

Parker Hannifin Corporation
 Pneumatic Division
 Richland, Michigan
www.parker.com/pneumatics

D
 Subbase & Manual Valves
 H Series Micro
 Modflex Series
 H Series ISO
 Fieldbus Systems
 DX ISOMAX Series
 Valvair II Series

H Series Fieldbus with H Series Micro Valves, Side Ported

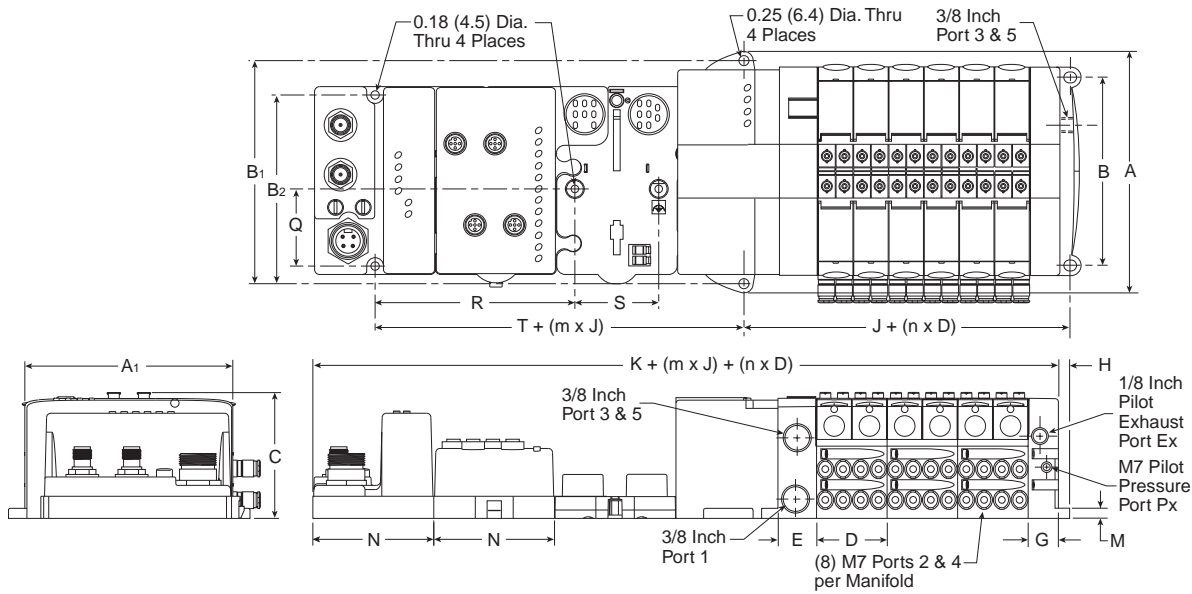

Dimensions

A	A₁	B	B₁	B₂	C	D	E	G
5.67 (144.0)	4.88 (124.0)	4.41 (112.0)	5.24 (133.0)	4.02 (102.0)	2.95 (75.0)	1.65 (42.0)	0.91 (23.0)	0.71 (18.0)
H	J	K	M	N	Q	R	S	T
0.49 (12.5)	2.72 (69.0)	7.32 (186.0)	0.24 (6.1)	2.83 (72.0)	1.81 (46.0)	4.72 (120.0)	2.01 (51.0)	2.01 (51.0)

Inches (mm)
 n = Number of Manifolds
 m = Number of Modules

H Series Fieldbus with H Series Micro Valves, Bottom Ported

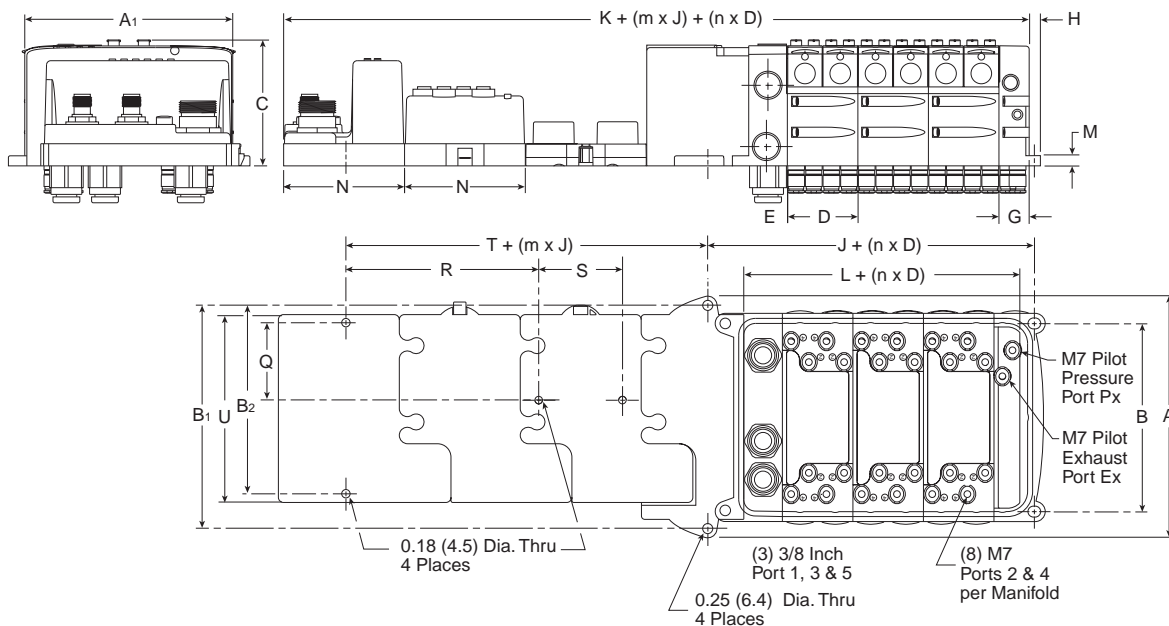

Dimensions

A	A₁	B	B₁	B₂	C	D	E	G	H
5.67 (144.0)	4.88 (124.0)	4.41 (112.0)	5.24 (133.0)	4.02 (102.0)	2.95 (75.0)	1.65 (42.0)	0.91 (23.0)	0.71 (18.0)	0.49 (12.5)
J	K	L	M	N	Q	R	S	T	U
2.72 (69.0)	7.32 (186.0)	1.69 (43.0)	0.24 (6.1)	2.83 (72.0)	1.81 (46.0)	4.72 (120.0)	2.01 (51.0)	2.01 (51.0)	4.41 (112)

Inches (mm)
 n = Number of Manifolds
 m = Number of Modules



For inventory, lead time, and kit lookup, visit www.pdnplu.com

D23

Parker Hannifin Corporation
 Pneumatic Division
 Richland, Michigan
www.parker.com/pneumatics

D

Subbase & Manual Valves

H Series Micro

Modulflex Series

H Series ISO

Fieldbus Systems

DX ISOMAX Series

Valvair II Series

Moduflex with H Series Micro Valves, Side Ported

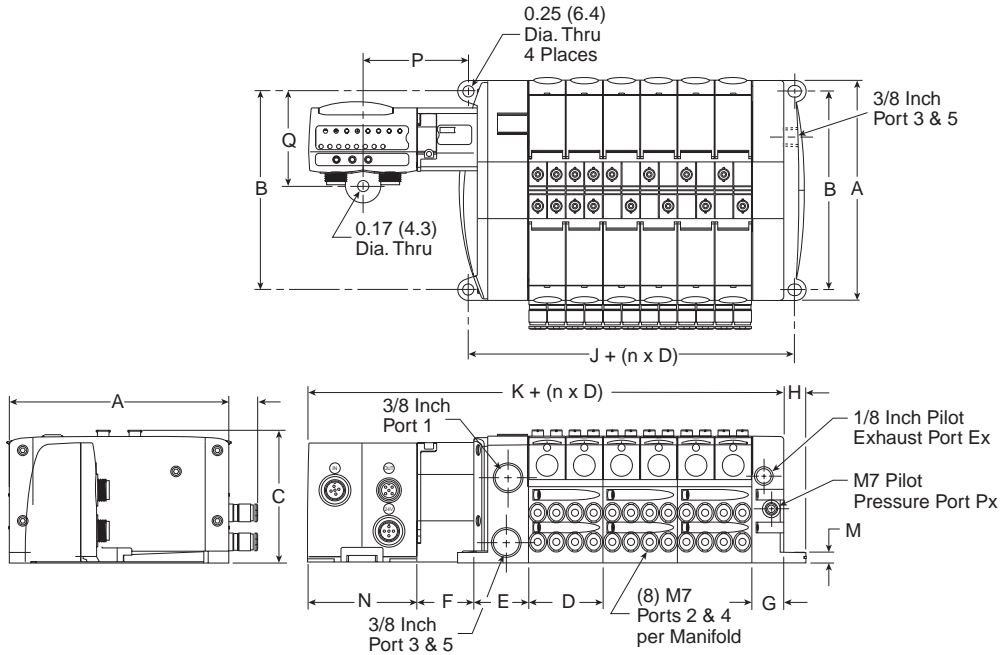

Dimensions

A	B	C	D
4.88 (124.0)	4.41 (112.0)	2.95 (75.0)	1.65 (42.0)
E	F	G	H
1.22 (31.0)	1.28 (32.5)	0.71 (18.0)	0.49 (12.5)
J	K	M	N
2.28 (58.0)	6.10 (155.0)	0.24 (6.1)	2.40 (61.0)
P	Q		
2.36 (60.0)	2.07 (52.55)		

Inches (mm)
 n = Number of manifolds

Moduflex with H Series Micro Valves, Bottom Ported

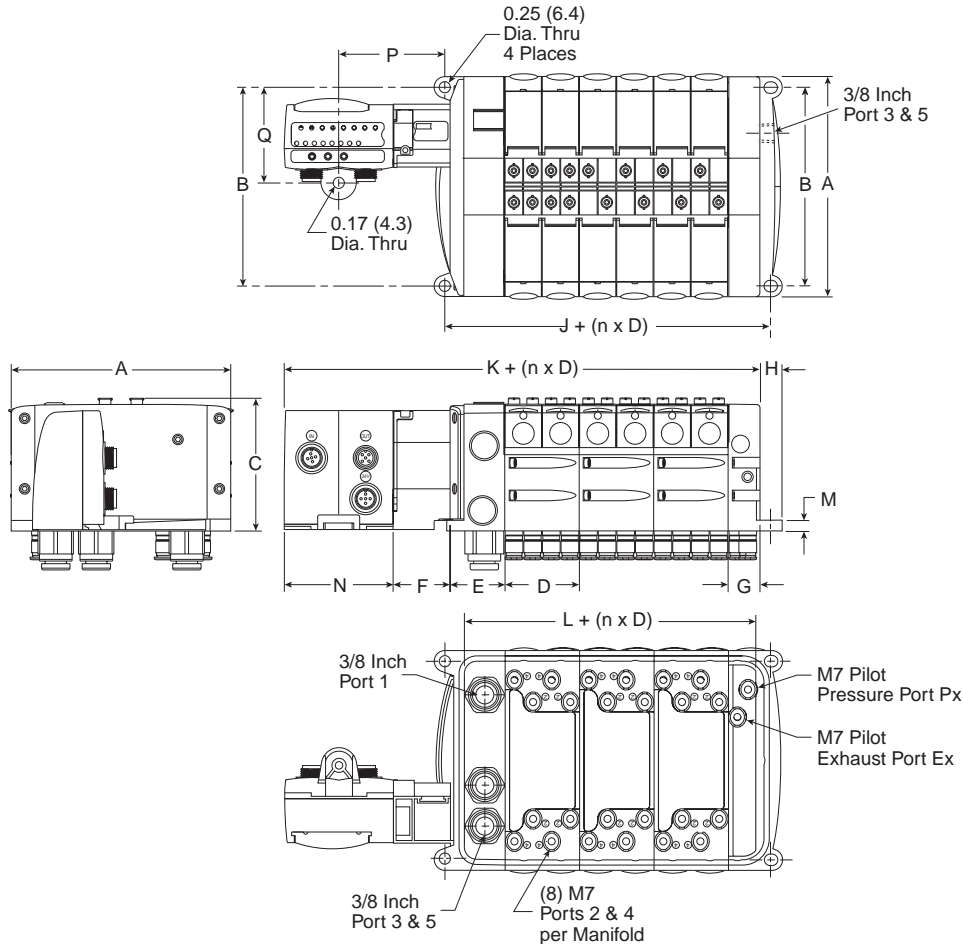

Dimensions

A	B	C	D
4.88 (124.0)	4.41 (112.0)	2.95 (75.0)	1.65 (42.0)
E	F	G	H
1.22 (31.0)	1.02 (26.0)	0.71 (18.0)	0.49 (12.5)
J	K	L	M
2.28 (58.0)	6.10 (155.0)	1.69 (43.0)	0.24 (6.1)
N	P	Q	
2.40 (61.0)	2.36 (60.0)	2.07 (52.55)	

Inches (mm)
 n = Number of manifolds

D
 Subbase & Manual Valves
 H Series Micro
 Moduflex Series
 H Series ISO
 Fieldbus Systems
 DX ISOMAX Series
 Valvair II Series



For inventory, lead times, and kit lookup, visit www.pdnplu.com

Turck with H Series Micro Valves, Side Ported

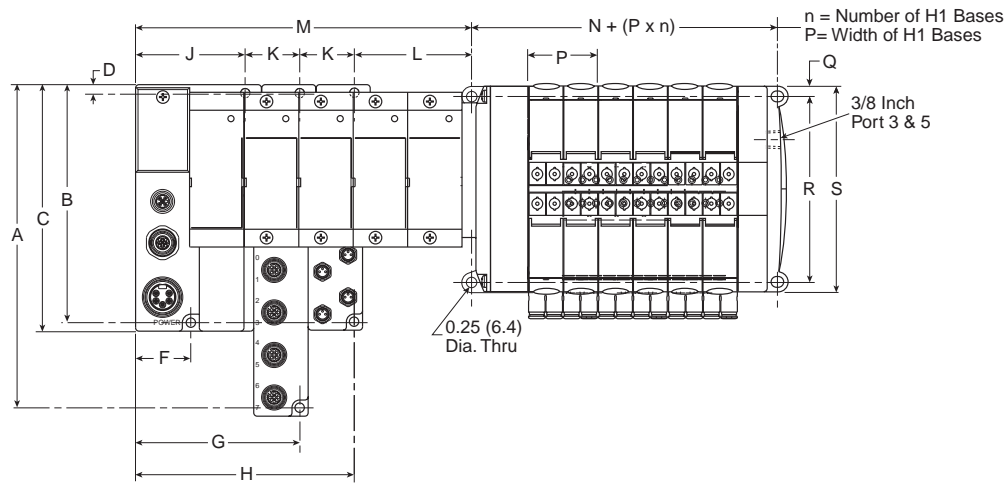

Dimensions

A	B	C	D
7.48 (190)	5.51 (140)	5.71 (145)	0.20 (5)
F	G	H	J
1.28 (32.5)	3.79 (96.5)	5.06 (128.5)	2.53 (64.5)
K	L	M	N
1.26 (32)	2.54 (64)	See note 1	2.28 (58)
P	Q	R	S
1.65 (42)	.19 (4.9)	4.41 (112)	4.88 (124)

Note 1: $M = J + L + n_2 \times K$, where n_2 = Number of Turck input / output modules
 Inches (mm)

Sandwich Regulator

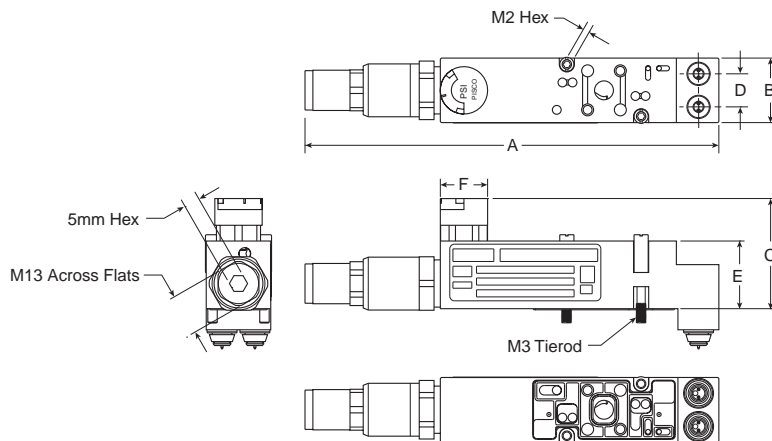

Dimensions

A	B	C	D
5.20 (132)	0.81 (20.5)	1.38 (35)	0.41 (10.5)
E	F		
0.85 (21.5)	0.59Ø (15Ø)		

Inches (mm)

M7 Fittings

PS567900 – Kit PSM0013

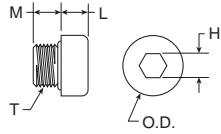

Part no.	L	M	H hex	T thread	O.D.
PS567900	0.18 (4.5)	0.20 (5)	0.16 (4)	M7 x 1	0.39 (10)

PS567906

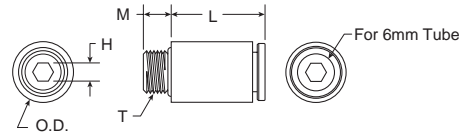

Part no.	Tube size	L	M	H Hex	T thread	O.D.
PS567906	6mm	0.63 (16)	0.20 (5)	0.12 (3)	M7 x 1	0.39 (10)

PS567904

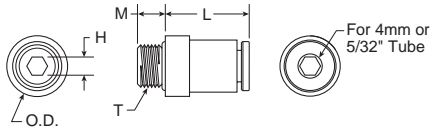

Part no.	Tube size	L	M	H Hex	T thread	O.D.
PS567904	4mm or 5/32"	0.55 (14)	0.20 (5)	0.12 (3)	M7 x 1	0.39 (10)

PS567925

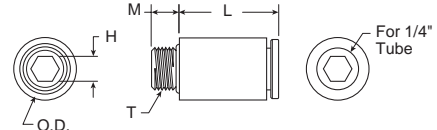

Part no.	Tube size	L	M	H Hex	T thread	O.D.
PS567925	1/4"	0.65 (16.5)	0.18 (4.6)	0.16 (4)	M7 x 1	0.41 (10.3)

1/8 Inch Fittings

PS568204

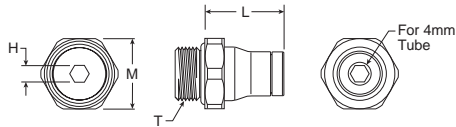

Part No.	Tube Size	L	M Hex	H Hex	T Thread
PS568204	4mm	0.57 (14.5)	0.51 (13)	0.12 (3)	G1 /8

PS568215

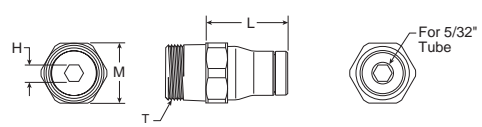

Part No.	Tube Size	L	M Hex	H Hex	T Thread
PS568215	5/32"	0.59 (15)	0.43 (11)	0.12 (3)	1/8 NPT

PS568206

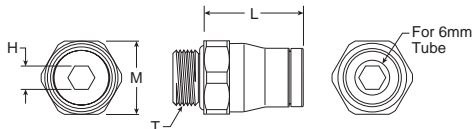

Part no.	Tube size	L	M Hex	H Hex	T thread
PS568206	6mm	0.69 (17.5)	0.51 (13)	0.16 (4)	G1/8

PS568225

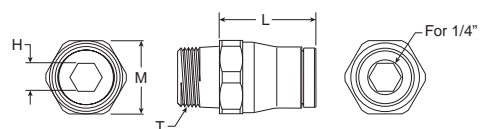

Part no.	Tube size	L	M Hex	H Hex	T thread
PS568225	1/4"	0.67 (17)	0.51 (13)	0.20 (5)	1/8 NPT

D
 Subbase & Manifold Valves
 H Series Micro
 Modulflex Series
 H Series ISO
 Fieldbus Systems
 DX ISOMAX Series
 Valvair II Series



For inventory, lead times, and kit lookup, visit www.pdnplu.com

3/8 Inch Fittings

PS568308

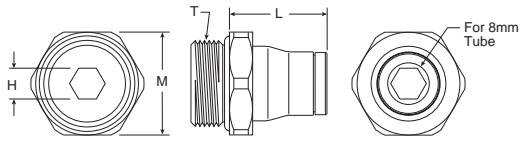

Part no.	Tube size	L	M Hex	H Hex	T thread
PS568308	8mm	0.75 (19)	0.79 (20)	0.24 (6)	G3/8

PS568325

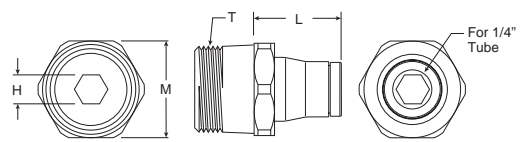

Part no.	Tube size	L	M Hex	H Hex	T thread
PS568325	1/4"	0.67 (17)	0.71 (18)	0.20 (5)	3/8 NPT

PS568310

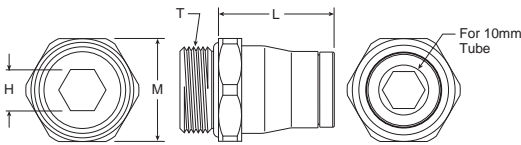

Part no.	Tube size	L	M Hex	H Hex	T thread
PS568310	10mm	0.89 (22.5)	0.79 (20)	0.31 (8)	G3/8

PS568338

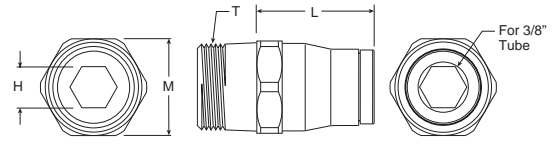

Part no.	Tube size	L	M Hex	H Hex	T thread
PS568338	3/8"	0.91 (23)	0.71 (18)	0.31 (8)	3/8 NPT

D

Subbase & Manual
Valves

H Series
Micro

Moduflex
Series

H Series
ISO

Fieldbus
Systems

DX ISOMAX
Series

Valvair II
Series



For inventory, lead time, and kit lookup, visit www.pdnplu.com

Features

Moduflex Series

The Moduflex Valve System redefines flexibility for pneumatic users. Whether configured from basic components or ordered as a pre-assembled and tested valve manifold, Moduflex flexibility is unmatched in the market place.

Ports

- Size 1: Push-in connectors for 5/32, 1/4 inch, 4, 6mm OD tube
- Size 2: Push-in connectors for 1/4, 3/8, 1/2 inch, 6, 8, 10, 12 mm OD tube

Mounting

- S Series – Individual subbase
- T Series – Manifold mount with individual connectors
- V Series – Manifold mount with collective wiring or fieldbus

Fieldbus options

- IO-Link – Class A & Class B
- DeviceNet, Profibus, CANopen, AS-i, Interbus-S

Solenoids

- 1.0 Watt
- 24 VDC
- Compatible with PNP or NPN outputs

Certification / approval

- IP65 rated
- CE, as marked

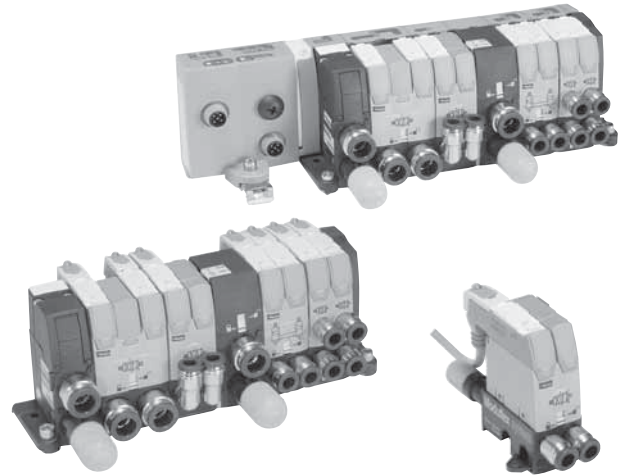

Operating information

Operating pressure:	Vacuum to 123 PSIG (Vacuum to 8.3 bar)
Operating temperature:	5°F to 140°F (-15°C to 60°C)
Fieldbus operating temperature:	32°F to 130°F (0°C to 55°C)

Material specifications

End plates (T and V series)	Plastic
Fasteners	Nickel plated steel
Spool	Aluminum and nitrile rubber or ceramic plate
Subbase or manifold	Plastic
Valve body	Plastic

D	Subbase & Manual Valves
H Series Micro	
Moduflex Series	
H Series ISO	
Fieldbus Systems	
DX ISOMAX Series	
Valvair II Series	

 Most popular.



For inventory, lead times, and kit lookup, visit www.pdnplu.com

Features

Module Series Selection and Assembly Procedures

Moduflex system provides a complete choice of either stand-alone valves, short-build valve islands, or large valve island configurations. Electrical control connections may be individual or island integrated. Peripheral modules add complementary functions — flow control, pressure regulation, P.O. check valves and vacuum generators can be added directly to the valve or used as a stand alone product.

Moduflex gives machine builders maximum flexibility to assemble each automation system step by step using basic modules.

Valve islands can be easily assembled using the following procedure.

1. Assemble the required valve island with the basic modules.
2. Mount the valve island on the machine together with any stand-alone valves and peripheral modules.
3. Select and install the required clip-on pneumatic and electrical connectors.

“S” Series Stand Alone Valves

For isolated cylinders on a machine, it is preferable to locate the valve close by. Therefore a stand-alone module is ideal. Response time and air consumption are then reduced to a minimum. Peripheral modules can be installed directly into the valve.



“S” Series Size 1 Single Solenoid



“S” Series Size 1 Single Air Pilot



Straight or Elbow Pneumatic Connectors



Union Pneumatic Connectors

Dual P.O. Check Valve



Subbase & Manifold Valve Products “S” & “T” Series

“T” Series Valve Island Modules with Individual Connectors

For small groups of cylinders requiring short localized valve islands, it is convenient to use individual electrical connector islands.



“T” Series Island Modules

“T” Series modules are easily assembled to form a complete manifold. All electrical connectors are individual and pneumatic connectors are of the push-in tube type. Modules with different functions and flow passages may be combined in the same island manifold, giving total flexibility to adapt to all machine requirements.

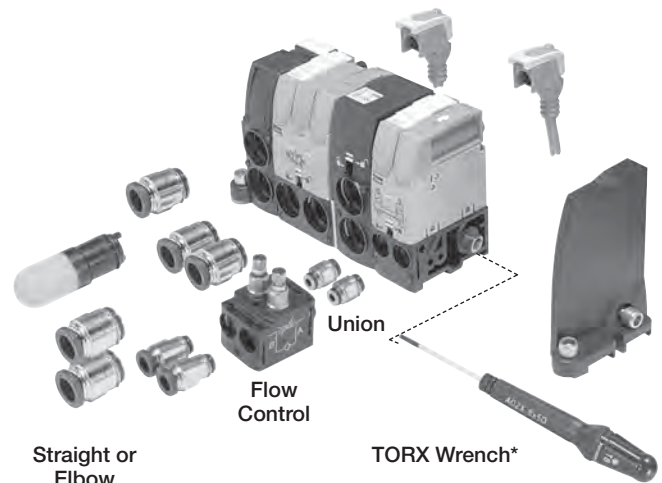

Straight or Elbow Pneumatic Connectors

TORX Wrench*

* Maximum torque rating 10.6 in. lbs. (1.2 Nm).



M8 2-pin, male connector



Clip Connector with LED & surge protection



For inventory, lead time, and kit lookup, visit www.pdnplu.com

Features

“V” Series Valve Island Modules with Integrated Connections

When the number of valves is larger, modular islands are easily assembled using the integrated electrical connection series. These islands are then connected to the control PLC, with a multi-connector cable or with a fieldbus connection.

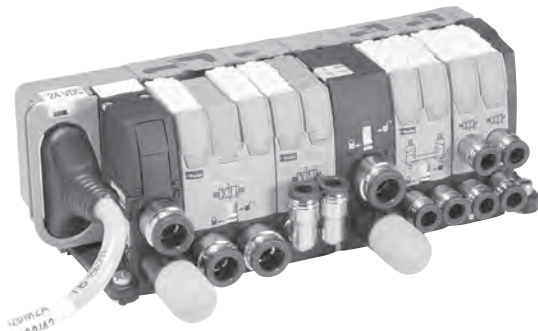

“V” Series with 20-Pin Connector



“V” Series with Field Bus Connection

“V” Series modules are easily assembled to form a complete manifold. All pneumatic connectors are of the push-in tube type. When the valve island has been installed, it is a simple operation to separate the field bus module from the valve island using the quick release lever. Modules with different functions and flow passages may be combined in the same island manifold, giving total flexibility to adapt to all machine requirements.

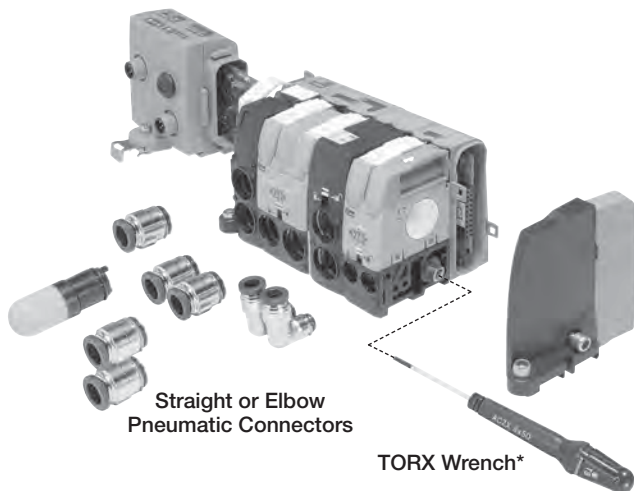

Straight or Elbow Pneumatic Connectors

TORX Wrench*

* Maximum torque rating 10.6 in. lbs. (1.2 Nm).

Subbase & Manifold Valve Products “V” & “P” Series

“P” Series Peripheral Modules

Peripheral Modules are available and can be mounted directly to valves or used as a stand alone product. These modules answer the complementary needs of the cylinders, flow controls, pressure regulation or positioning.



Flow Control



Pressure Regulator



Dual P.O. Check Valve

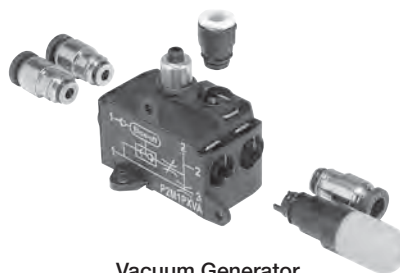

Vacuum Generator

D	Subbase & Manual Valves
	H Series Micro
Modulflex Series	
H Series ISO	
Fieldbus Systems	
DX ISOMAX Series	
Valvair II Series	



For inventory, lead times, and kit lookup, visit www.pdnplu.com

Valve Function

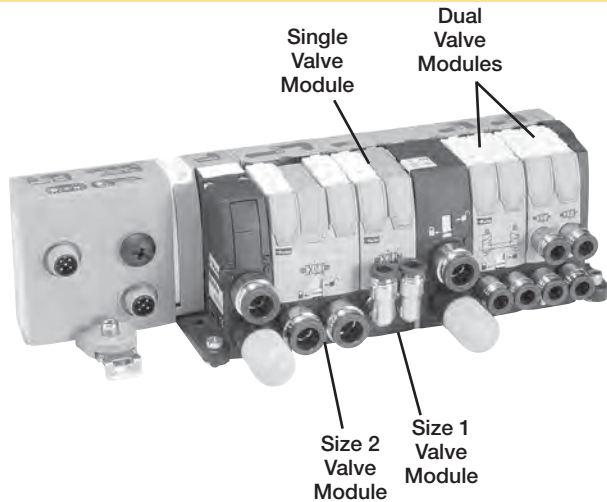









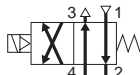

Moduflex Valve Islands offer the greatest flexibility for your design requirements.

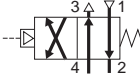
Valve Modules are available as 4-Way or 3-Way valves and can be ordered as single or dual valves. A Single Valve Module has one valve in one valve body. A Dual Valve Module will have 2 valves in one valve body. Each Valve in the Dual Valve Body is controlled by a solenoid or air pilot and can be operated independently from the other valve in the same body. There are no dimensional difference between a single and a dual valve. Flow Rates are reduced on the dual valves.

Single valve modules offer Ceramic Slide Valve Technology while dual valve modules offer WCS – Wear Compensation System Technology. Both offer low friction shift forces, fast response and less spool wear.

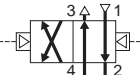
Valve Modules are available in two different valve body sizes. Size 1 and Size 2 Valve Modules can be combined in both “T” and “V” Series Valve Islands without transition kits.

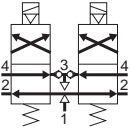
4/2, 4-Way, 2-Position Valves

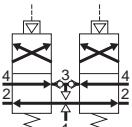
Single Valves	ANSI Symbol	Description	Size 1 Body	Size 2 Body
		Single Solenoid, Spring Return Valve	Cv = .32	Cv = .80
		Single Air Pilot, Spring Return Valve		
		Double Solenoid Valve	Cv = .32	Cv = .80
		Double Air Pilot Valve		
Dual Valves	ANSI Symbol	Description	Size 1 Body	Size 2 Body
		(2) Single Solenoid, Spring Return Valve with Exhaust Check. Double Solenoid Valve Body	Cv = .18	N/A
		(2) Single Air Pilot, Spring Return Valve with Exhaust Check. Double Air Pilot Valve Body		

D

Subbase & Manual Valves

H Series Micro

Moduflex Series

H Series ISO

Fieldbus Systems

DX ISOMAX Series

Valvair II Series











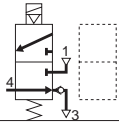

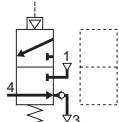
For inventory, lead time, and kit lookup, visit www.pdnplu.com

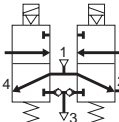
D31

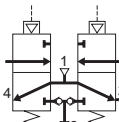
Parker Hannifin Corporation
 Pneumatic Division
 Richland, Michigan
www.parker.com/pneumatics

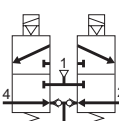
3/2, 3-Way, 2-Position Valves

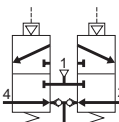
Single Valves	ANSI Symbol	Description	Size 1 Body	Size 2 Body
		Single Solenoid, NC, Spring Return Valve with Exhaust Check.	Cv = .22	Cv = .44
		Single Air Pilot, NC, Spring Return Valve with Exhaust Check.		
Dual Valves	ANSI Symbol	Description	Size 1 Body	Size 2 Body
		(2) Single Solenoid, NO, Spring Return Valve with Exhaust Check. Double Solenoid Valve Body	Cv = .22	Cv = .44
		(2) Single Air Pilot, NO, Spring Return Valve with Exhaust Check. Double Air Pilot Valve Body		
		(2) Single Solenoid, NC, Spring Return Valve with Exhaust Check. Double Solenoid Valve Body	Cv = .22	Cv = .44
		(2) Single Air Pilot, NC, Spring Return Valve with Exhaust Check. Double Air Pilot Valve Body		

Dual 3/2 Valves Replace All 3-Position Valves for a Better Performance

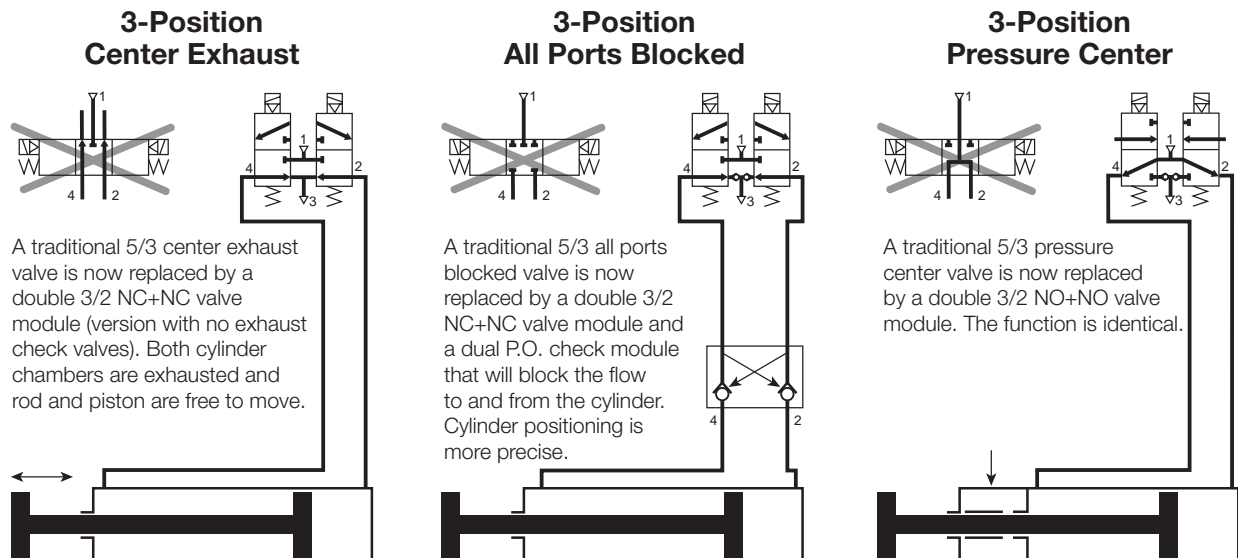

For inventory, lead times, and kit lookup, visit www.pdnplu.com











D32

Parker Hannifin Corporation
Pneumatic Division
Richland, Michigan
www.parker.com/pneumatics

D
 Subbase & Manifold Valves
 H Series Micro
 Moduflex Series
 H Series ISO
 Fieldbus Systems
 DX ISOMAX Series
 Valvair II Series

Common Part Numbers

"S" Series Individual Subbase Valves (Valve & Base without Pneumatic Connectors)

	Symbol	Type	Operator	Pilot connector	Cv	Part number	
						Size 1	Size 2
 Single Solenoid		4-way, 2-position	Single solenoid	M8 Lockable	0.32	P2M1S4ES2C	P2M2S4ES2C
				Clip		P2M1S4ES2CW	P2M2S4ES2CW
			Single air pilot			P2M1S4PS	P2M2S4PS
		4-way, 2-position	Double solenoid	M8 Lockable	0.32	P2M1S4EE2C	P2M2S4EE2C
				Clip		P2M1S4EE2CW	P2M2S4EE2CW
			Double air pilot			P2M1S4PP	P2M2S4PP
 Double Solenoid		3-way, 2-position, dual valve, NC/NC w/ exhaust check	Double solenoid	M8 Lockable	0.22	P2M1SDEE2C	P2M2SDEE2C
				Clip		P2M1SDEE2CW	P2M2SDEE2CW
			Double air pilot			P2M1SDPP	P2M2SDPP
		3-way, 2-position, dual valve, NO/NO w/ exhaust check	Double solenoid	M8 Lockable	0.22	P2M1SCEE2C	P2M2SCEE2C
				Clip		P2M1SCEE2CW	P2M2SCEE2CW
			Double air pilot			P2M1SCPP	P2M2SCPP
 Single Air Pilot		3-way, 2-position, dual valve, NC/NO w/ exhaust check	Double solenoid	M8 Lockable	0.22	P2M1SEEE2C	P2M2SEEE2C
				Clip		P2M1SEEE2CW	P2M2SEEE2CW
				3-way, 2-position, NC w/ exhaust check		Single solenoid	M8 Lockable
		Clip			P2M1S3ES2CW	P2M2S3ES2CW	
	Single air pilot				P2M1S3PS	P2M2S3PS	
		3-way, 2-position, dual valve, NC/NC	Double solenoid	M8 Lockable	0.22	P2M1SGEE2C	P2M2SGEE2C
			Clip	P2M1SGEE2CW		P2M2SGEE2CW	

Note: Includes 5/32" (4mm) Air Pilot Connectors.



M8 2-pin, male connector

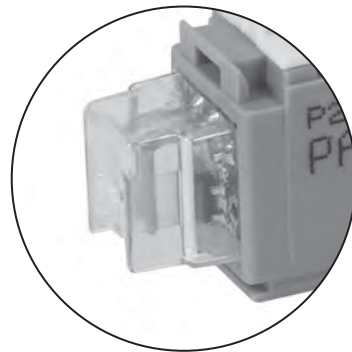

Clip Connector with LED & surge protection

 Most popular.



For inventory, lead time, and kit lookup, visit www.pdnplu.com

D33

Parker Hannifin Corporation
Pneumatic Division
Richland, Michigan
www.parker.com/pneumatics

D

Subbase & Manual Valves

H Series Micro

Moduflex Series







H Series ISO

Fieldbus Systems

DX ISOMAX Series

Valvair II Series

"S" Series Accessories

Description	Tube Size (OD)	Option	Part number	Part number
			Size 1	Size 2
 Push to connect fitting	5/32"	Elbow	CMD04-1	—
		Straight	FMD04-1	—
	1/4"	Elbow	CMD07-1B	CMD07-2B
		Straight	FMD07-1B	FMD07-2B
	3/8"	Elbow	—	CMD09-2B
		Straight	—	FMD09-2B
	1/2"	Straight	—	FMD13-2B
	6mm	Elbow	CMD06-1	CMD06-2
		Straight	FMD06-1	FMD06-2
	8mm	Elbow	—	CMD08-2
		Straight	—	FMD08-2
	10mm	Elbow	—	CMD10-2
		Straight	—	FMD10-2
	12mm	Elbow	—	CMD12-2
Straight		—	FMD12-2	
 Muffler for exhaust port			MMDVA1	MMDVA2
 Plug			—	PMDYY2
 Double male union		Connecting peripheral modules	HMDXX1	HMDXX2
 M8 female connector to flying lead - IP67 LED and surge protection		2m Cable	P8LS08L226C	P8LS08L226C
		5m Cable	P8LS08L526C	P8LS08L526C
		9m Cable	P8LS08L926C	P8LS08L926C
 Clip connector – IP40 Individual: including 2 flying leads Multiple: 1 common (0 VDC) and 1 flying lead per connector	1 x Clip connector	1 meter	P8LW021C	P8LW021C
	2 x Clip connector	1 meter	P8LW021C02	P8LW021C02
	4 x Clip connector	1 meter	P8LW021C04	P8LW021C04
	8 x Clip connector	1 meter	P8LW021C08	P8LW021C08
 Field wireable connector		M8 Connector	P8CS0803J	P8CS0803J
		M12 Connector	P8CS1204J	P8CS1204J

Note: 85 Durometer minimum for pneumatic connectors.

 Most popular.

D
 Subbase & Manual Valves
 H Series Micro
 Moduflex Series
 H Series ISO
 Fieldbus Systems
 DX ISOMAX Series
 Valvair II Series



For inventory, lead times, and kit lookup, visit www.pdnplu.com

"S" Series Individual Subbase Valve
(Complete with Pneumatic and Electrical Connectors)

P2M 1 S 4ES 2C 00 A F4

Basic series			Ports (all ports)
Moduflex	P2M		C0* 10mm Elbow fitting
			C2* 12mm Elbow fitting
			C4 5/32" (4mm) Elbow fitting
			C6 6mm Elbow fitting
			C7 1/4" Elbow fitting
			C8* 8mm Elbow fitting
			C9* 3/8" Elbow fitting
			F0* 10mm Straight fitting
			F2* 12mm Straight fitting
			F3* 1/2" Straight fitting
			F4 5/32" (4mm) Straight fitting
			F6 6mm Straight fitting
			F7 1/4" Straight fitting
			F8* 8mm Straight fitting
			F9* 3/8" Straight fitting

* Only available with size 2 valves.

Size			
Size 1	1		
Size 2	2		

Valve series			
Individual subbase	S		

Valve type / function			
3-way / 2-position			
Single solenoid, NC spring return	3ES		
Single air pilot, NC spring return	3PS		
4-way / 2-position			
Single solenoid, spring return	4ES		
Single air pilot, spring return	4PS		
Double solenoid	4EE		
Double air pilot	4PP		
Dual 3-way, 2-position, spring return			
Solenoid, NC / NC + PO check (4/3 APB)	BEE*		
Air pilot, NC / NC + PO check (4/3 APB)	BPP*		
Solenoid, NO / NO (4/3 Pressure Ctr.)	CEE		
Air pilot NO / NO (4/3 Pressure Ctr.)	CPP		
Solenoid, NC / NC with exhaust check			
Air pilot, NC / NC with exhaust check	DPP		
Solenoid, NO / NC with exhaust check	EEE		
Solenoid, NC / NC without check (4/3 Exh. Ctr.)	GEE		

Fitting configuration			
A*	Straight fittings		
B*	Elbow fittings		
C*†	Straight fitting & muffler		
D*†	Elbow fitting & muffler		

* Ports 1 & 3 fittings sizes are same as ports 2 & 4 (see example at left.)
 † Fitting in port 1, muffler in port 3.

LED / Cable			
00	No cable, no LED, no surge suppression		
V2	2 Meter cable with LED and surge suppression		
V5	5 Meter cable with LED and surge suppression		
V9	9 Meter cable with LED and surge suppression		
W0	No Cable		
W1	1 Meter cable, clip connector		

Operator voltage			
24VDC	2C		
Remote pilot - 5/32" (4mm) Tube	00		

* Valve includes peripheral P. O. Check Valve and union fittings.

Example for fitting configuration:

Size 1

CF7 Ports 1 & 3
1/4" straight fitting & muffler
Ports 2 & 4
1/4" straight fittings

Size 2

AC0 Ports 1 & 3
10mm elbow fittings
Ports 2 & 4
10mm elbow fittings

Subbase & Manual Valves

H Series Micro

Moduflex Series

H Series ISO

Fieldbus Systems

DX ISOMAX Series

Valvair II Series

With only one universal solenoid pilot for all configurations

24VDC is now a global standard for all machines. The Moduflex 24VDC unique solenoid pilot is supplied with the multi-function manual override that can be adapted to all requirements, as explained by the drawings.

Multi-function adaptable manual override

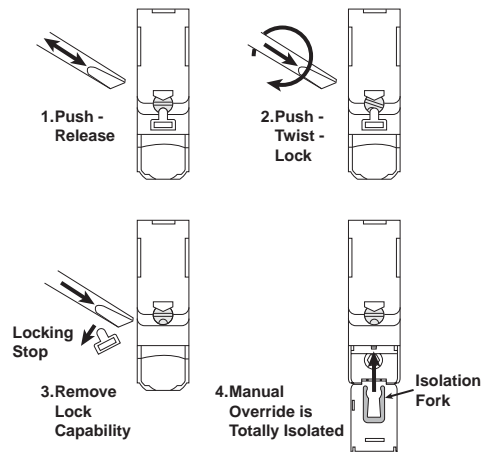

 Most popular.



For inventory, lead time, and kit lookup, visit www.pdnplu.com



Example:

Size 1, 4-Way Single Solenoid valve with 1/4" Straight Connectors in Ports 1, 2 and 4. Exhaust Muffler in Port 3. Valve to include 2m cable with LED and surge suppression.

"S" Series Single Solenoid

How to Order Complete Valve Assembly

Line Item	Quantity	Part Number	Description
1	1	P2M1S4ES2CV2CF7	Size 1, Individual Subbase Valve, 4 Way, Single Solenoid, 2m Cable with LED / Surge Suppression, Exhaust Muffler with 1/4" OD Straight Port Fittings

Notes:

1. Cables supplied loose with valve.
2. For LED and Surge Suppressor, cable must be supplied with valve.

How to Order Components

Line item	Quantity	Part number	Description
1	1	P2M1S4ES2C	Size 1, Individual Subbase Valve, Single Solenoid, 4 Way
2	1	P8LS08L226C	2m Cable with LED / Surge Suppression
3	3	FMD07-1B	Size 1, 1/4" OD Tube Push In Connector
4	1	MMDVA1	Size 1, Muffler for Exhaust Port

D

Subbase & Manual Valves

H Series Micro

Moduflex Series

H Series ISO

Fieldbus Systems













DX ISOMAX Series

Valvair II Series



For inventory, lead times, and kit lookup, visit www.pdnplu.com

"T" Series Manifold Valves with Individual Connectors

	Symbol	Type	Operator	Pilot connector	Cv	Part number	
						Size 1	Size 2
		4-way, 2-position	Single solenoid	M8 Lockable	0.32	P2M1T4ES2C	P2M2T4ES2C
			Clip			P2M1T4ES2CW	P2M2T4ES2CW
			Single air pilot			P2M1T4PS	P2M2T4PS
		4-way, 2-position	Double solenoid	M8 Lockable	0.32	P2M1T4EE2C	P2M2T4EE2C
			Clip			P2M1T4EE2CW	P2M2T4EE2CW
			Double air pilot			P2M1T4PP	P2M2T4PP
		4-way, 2-position, dual valve w/ exhaust check	Double solenoid	M8 Lockable	0.18	P2M1TJEE2C	—
			Clip			P2M1TJEE2CW	—
			Double air pilot			P2M1TJPP	—
		3-way, 2-position, dual valve, NC/NC w/ exhaust check	Double solenoid	M8 Lockable	0.22	P2M1TDEE2C	P2M2TDEE2C
			Clip			P2M1TDEE2CW	P2M2TDEE2CW
			Double air pilot			P2M1TDPP	P2M2TDPP
		3-way, 2-position, dual valve, NO/NO w/ exhaust check	Double solenoid	M8 Lockable	0.22	P2M1TC EE2C	P2M2TCEE2C
			Clip			P2M1TC EE2CW	P2M2TCEE2CW
			Double air pilot			P2M1TCPP	P2M2TCPP
		3-way, 2-position, dual valve, NC/NO w/ exhaust check	Double solenoid	M8 Lockable	0.22	P2M1TEEE2C	P2M2TEEE2C
			Clip			P2M1TEEE2CW	P2M2TEEE2CW
			Single air pilot			P2M1T3PS	P2M2T3PS
		3-way, 2-position, NC w/ exhaust check	Single solenoid	M8 Lockable	0.22	P2M1T3ES2C	P2M2T3ES2C
			Clip			P2M1T3ES2CW	P2M2T3ES2CW
			Single air pilot			P2M1T3PS	P2M2T3PS
		3-way, 2-position, dual valve, NC/NC	Double solenoid	M8 Lockable	0.22	P2M1TGEE2C	P2M2TGEE2C
			Clip			P2M1TGEE2CW	P2M2TGEE2CW

Note: Includes 5/32" (4mm) Air Pilot Connectors.

Manifold Options

Module	Part number
Pneumatic end plate kit	P2M2HXT01*
Pneumatic end plate kit with torx screwdriver	P2M2HXT0T*
Intermediate supply module (Includes 4 configuration plates)	P2M2BXT0A*

* Use Fittings for Size 2 Modules Only



M8 2-pin, male connector

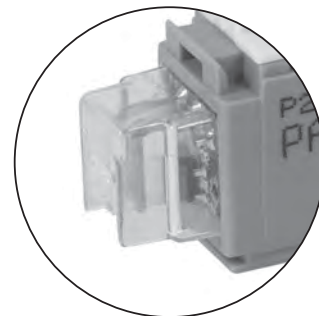

Clip Connector with LED & surge protection

 Most popular.



For inventory, lead time, and kit lookup, visit www.pdnplu.com

D37

Parker Hannifin Corporation
Pneumatic Division
Richland, Michigan
www.parker.com/pneumatics

D

Subbase & Manual Valves

H Series Micro

Moduflex Series









H Series ISO

Fieldbus Systems

DX ISOMAX Series

Valvair II Series

"T" Series Size Accessories

Description	Tube size OD	Option	Part number	Part number	
			Size 1	Size 2	
 <p>Push to connect fitting</p>	5/32" or 4mm	Elbow	CMD04-1	—	
		Straight	FMD04-1	—	
	1/4"	Elbow	CMD07-1B	CMD07-2B	
		Straight	FMD07-1B	FMD07-2B	
	3/8"	Elbow	—	CMD09-2B	
		Straight	—	FMD09-2B	
	1/2"	Straight	—	FMD13-2B	
	6mm	Elbow	CMD06-1	CMD06-2	
		Straight	FMD06-1	FMD06-2	
	8mm	Elbow	—	CMD08-2	
		Straight	—	FMD08-2	
	10mm	Elbow	—	CMD10-2	
		Straight	—	FMD10-2	
	12mm	Elbow	—	CMD12-2	
Straight		—	FMD12-2		
 <p>Muffler for exhaust port</p>			MMDVA1	MMDVA2	
 <p>Plug</p>			PMDYY1	PMDYY2	
 <p>Double male union</p>		Connecting peripheral modules	HMDXX1	HMDXX2	
 <p>M8 female connector to flying lead - IP67 LED and surge protection</p>		2M cable	P8LS08L226C	P8LS08L226C	
		5M cable	P8LS08L526C	P8LS08L526C	
		9M cable	P8LS08L926C	P8LS08L926C	
 <p>Clip connector – IP40</p>	1 x Clip connector	1 meter	P8LW021C	P8LW021C	
	Individual: including 2 flying leads	2 x Clip connector	1 meter	P8LW021C02	P8LW021C02
	Multiple: 1 common (0 VDC) and 1 flying lead per connector	4 x Clip connector	1 meter	P8LW021C04	P8LW021C04
		8 x Clip connector	1 meter	P8LW021C08	P8LW021C08
 <p>Field wireable connector</p>		M8 connector	P8CS0803J	P8CS0803J	
		M12 connector	P8CS1204J	P8CS1204J	
 <p>Torx screwdriver</p>			P2M1K0TASD	P2M1K0TASD	

Note: 85 Durometer minimum for pneumatic connectors.

 Most popular.

D
Subbase & Manual Valves
H Series Micro
Moduflex Series
H Series ISO
Fieldbus Systems
DX ISOMAX Series
Valvair II Series



For inventory, lead times, and kit lookup, visit www.pdnplu.com

"T" Series Valve Manifold with Individual Connectors
(Complete with Pneumatic and Electrical Connectors)

P2M 1 T 4ES 2C 00 0 F4

Basic series			Ports 2 & 4
Valvetronic modules	P2M		C0* 10mm Elbow fitting
Size			C2* 12mm Elbow fitting
Size 1	1		C4 5/32" (4mm) Elbow fitting
Size 2	2		C6 6mm Elbow fitting
Valve series			C7 1/4" Elbow fitting
Individual wire	T		C8* 8mm Elbow fitting
			C9* 3/8" Elbow fitting
Valve type / function			F0* 10mm Straight fitting
<i>3-way / 2-position</i>			F2* 12mm Straight fitting
Single solenoid, NC spring return	3ES		F3* 1/2" Straight fitting
Single air pilot, NC spring return	3PS		F4 5/32" (4mm) Straight fitting
<i>4-way / 2-position</i>			F6 6mm Straight fitting
Single solenoid, spring return	4ES		F7 1/4" Straight fitting
Single air pilot, spring return	4PS		F8* 8mm Straight fitting
Double solenoid	4EE		F9* 3/8" Straight fitting
Double air pilot	4PP		
<i>Dual 3-way, 2-position, spring return</i>			
Solenoid, NC / NC + PO check (4/3 APB)	BEE*		
Air pilot, NC / NC + PO check (4/3 APB)	BPP*		
Solenoid, NO / NO (4/3 Pressure Ctr.)	CEE		
Air pilot NO / NO (4/3 Pressure Ctr.)	CPP		
Solenoid, NC / NC with exhaust check	DEE		
Air pilot, NC / NC with exhaust check	DPP		
Solenoid, NO / NC with exhaust check	EEE		
Solenoid, NC / NC without check (4/3 Exh. Ctr.)	GEE		
<i>Dual 4-way, 2-position, Spring Return</i>			
Solenoid	JEE**		
Air pilot	JPP**		

* Only available with size 2 valves.

		Ports 1 & 3	
		0	None

		LED / Cable	
		00	No cable, no LED, no surge suppression
		V2	2 Meter cable with LED and surge suppression
		V5	5 Meter cable with LED and surge suppression
		V9	9 Meter cable with LED and surge suppression
		W0	No Cable
		W1	1 Meter cable, clip connector

		Operator Voltage	
		2C	24VDC
		00	Remote pilot - 5/32" (4mm) tube

* Valve includes peripheral P. O. check valve and union fittings.
 ** Size 1 only.

With only one universal solenoid pilot for all configurations

24VDC is now a global standard for all machines. The Moduflex 24VDC unique solenoid pilot is supplied with the multi-function manual override that can be adapted to all requirements, as explained by the drawings.

Multi-function adaptable manual override

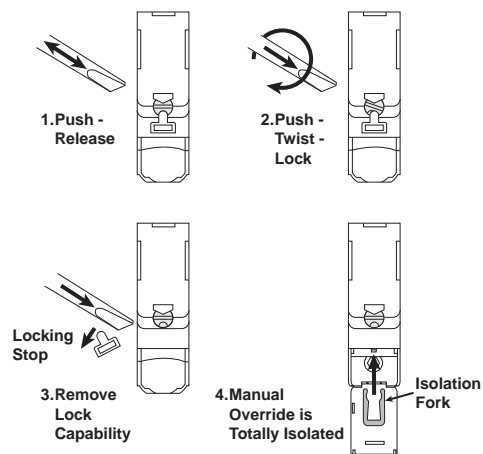

 Most popular.



For inventory, lead time, and kit lookup, visit www.pdnplu.com

D39

Parker Hannifin Corporation
 Pneumatic Division
 Richland, Michigan
www.parker.com/pneumatics

D

Subbase & Manual Valves

H Series Micro

Moduflex Series

H Series ISO

Fieldbus Systems

DX ISOMAX Series

Valvair II Series

Ordering Information

Subbase & Manifold Valve Products Moduflex "T" Series



Example:

Size 1, 4-Way Single Solenoid valve with 1/4" Straight Connectors in Ports 2 and 4. Valve to include 2m cable with LED and surge suppression.

"T" Series Single Solenoid

How to Order Complete Valve Assembly

Line item	Quantity	Part number	Description
1	1	P2M1T4ES2CV20F7	Size 1, T Series Manifold Valves, 4 Way, Single Solenoid, 2m Cable with LED / Surge Suppression, 1/4" OD Straight Port Fittings

Notes:

1. Cables supplied loose with valve.
2. For LED and Surge Suppressor, cable must be supplied with valve.
3. To assemble into a manifold, Pneumatic Head and Tail Set must be ordered separately.

How to Order Components

Line Item	Quantity	Part Number	Description
1	1	P2M1T4ES2C	Size 1, T Series Manifold Valves, Single Solenoid, 4 Way
2	1	P8LS08L226C	2m Cable with LED / Surge Suppression
3	2	FMD07-1B	Size 1, 1/4" OD Tube Push In Connector

D

Subbase & Manual
Valves

H Series
Micro

Moduflex
Series

H Series
ISO

Fieldbus
Systems

DX ISOMAX
Series

Valvair II
Series













For inventory, lead times, and kit lookup, visit www.pdnplu.com

D40

Parker Hannifin Corporation
Pneumatic Division
Richland, Michigan
www.parker.com/pneumatics

Common Part Numbers

"V" Series Manifold Valves with Collective Wiring

	Symbol	Type	Operator	Cv	Part number	
					Size 1	Size 2
 <p>Single Solenoid</p>		4-way, 2-position	Single solenoid	0.32	P2M1V4ES2CV	0.8 P2M2V4ES2CV
		4-way, 2-position	Double solenoid	0.32	P2M1V4EE2CV	0.8 P2M2V4EE2CV
		4-way, 2-position, dual valve, w/ exhaust check	Double solenoid	0.18	P2M1VJEE2CV	
		3-way, 2-position, dual valve, NC/NC w/ exhaust check	Double solenoid	0.22	P2M1VDEE2CV	0.44 P2M2VDEE2CV
 <p>Double Solenoid</p>		3-way, 2-position, dual valve, NO/NO w/ exhaust check	Double solenoid	0.22	P2M1VCEE2CV	0.44 P2M2VCEE2CV
		3-way, 2-position, dual valve, NC/NO w/ exhaust check	Double solenoid	0.22	P2M1VEEE2CV	0.44 P2M2VEEE2CV
		3-way, 2-position, dual valve, NC/NO w/ exhaust check	Double solenoid	0.22	P2M1VEEE2CV	0.44 P2M2VEEE2CV
		3-way, 2-position, NC w/ exhaust check	Single solenoid	0.22	P2M1V3ES2CV	0.44 P2M2V3ES2CV
		3-way, 2-position, dual valve, NC/NC	Double solenoid	0.22	P2M1VGEE2CV	0.44 P2M2VGEE2CV

 Most popular.



For inventory, lead time, and kit lookup, visit www.pdnplu.com

D41

Parker Hannifin Corporation
Pneumatic Division
Richland, Michigan
www.parker.com/pneumatics

D

Subbase & Manual Valves

H Series Micro

Moduflex Series









H Series ISO

Fieldbus Systems

DX ISOMAX Series

Valvair II Series

"V" Series Accessories

Description	Tube size OD	Option	Part number	
			Size 1	Size 2
 Push to connect fitting	5/32"	Elbow	CMD04-1	—
		Straight	FMD04-1	—
	1/4"	Elbow	CMD07-1B	CMD07-2B
		Straight	FMD07-1B	FMD07-2B
	3/8"	Elbow	—	CMD09-2B
		Straight	—	FMD09-2B
	1/2"	Straight	—	FMD13-2B
		6mm	Elbow	CMD06-1
		Straight	FMD06-1	FMD06-2
	8mm	Elbow	—	CMD08-2
		Straight	—	FMD08-2
	10mm	Elbow	—	CMD10-2
Straight		—	FMD10-2	
12mm	Elbow	—	CMD12-2	
	Straight	—	FMD12-2	
 Muffler for exhaust port		—	MMDVA1	MMDVA2
 Plug		—	PMDYY1	PMDYY2
 Double male union		Connecting peripheral modules	HMDXX1	HMDXX2
 Electrical 20-pin multi-connector cable with flying leads	IP65 rated	2M cable	P8LMH20M2A	P8LMH20M2A
		5M cable	P8LMH20M5A	P8LMH20M5A
		9M cable	P8LMH20M9A	P8LMH20M9A
 Electrical 25-pin D-sub cable	IP20 rated	3M cable	P8LMH25M3A	P8LMH25M3A
		9M cable	SCD259D	SCD259D
	IP65 rated	3M cable	SCD253W	SCD253W
		9M cable	SCD259WE	SCD259WE
Field wireable connector for power supply	Female	M12 - A code	P8CS1205AA	
Line termination resistor	Profibus DP	M12 type B	P8BPA00MB	
	Devicenet or Canopen	M12 type A	P8BPA00MA	
 Power & Communication Cable	IO-Link	5-pin male to female cable, TPE	RKC 4.5T*-RSC 4.5T/S1587	
AS-i M12 cable with jack for addressing		1M cable	P8LS12JACK	
 Torx screwdriver		—	P2M1K0TASD	P2M1K0TASD

Where * = 1, 2, 3, 4, 5, 10, 20 meter standard lengths

Note: 85 Durometer minimum for pneumatic connectors.

D
 Subbase & Manual Valves
 H Series Micro
 Moduflex Series
 H Series ISO
 Fieldbus Systems
 DX ISOMAX Series
 Valvair II Series



For inventory, lead times, and kit lookup, visit www.pdnplu.com

Electrical Connections

Description	Part number
20-pin, Multi-connector electrical head module	P2M2HEV0A
25-pin, D-sub, electrical head module	P2M2HEV0D



P2M2HEV0A



P2M2HEV0D

Fieldbus Connections

Description		Part number
IO-Link Class A	3-Pin, Aux power 1 & 3	P2M2HBVL12400A13
IO-Link Class A	3-Pin, Aux power 4 & 3	P2M2HBVL12400A43
IO-Link Class A	3-Pin, Aux power 4 & 2	P2M2HBVL12400A42
IO-Link Class B	5-Pin, Aux power 2 & 5	P2M2HBVL12400B25
Profibus DP		P2M2HBVP21600
DeviceNet		P2M2HBVD21600
CANopen		P2M2HBVC21600
Interbus S		P2M2HBVS11600
AS-i	0 inputs and 8 solenoid outputs	P2M2HBVA10800
AS-i	8 (PNP) inputs on eight (M8) connectors and 8 solenoid outputs	P2M2HBVA10808A
AS-i	8 (PNP) inputs on four (M12) connectors and 8 solenoid outputs	P2M2HBVA10808B
AS-i Version 2.1 ProtocolAS-i	0 inputs and 6 solenoid outputs	P2M2HBVA20600
AS-i Version 2.1 ProtocolAS-i	8 (PNP) inputs on eight (M8) connectors and 6 solenoid outputs	P2M2HBVA20608A
AS-i Version 2.1 ProtocolAS-i	8 (PNP) inputs on four (M12) connectors and 6 solenoid outputs	P2M2HBVA20608B

Manifold Options

Module	Part number
Pneumatic end plate kit	P2M2HXT01*
Pneumatic end plate kit with torx screwdriver	P2M2HXT0T*
Intermediate supply module (Includes 4 configuration plates)	P2M2BXV0A*

* Use Fittings for Size 2 Modules Only



P2M2HXT01

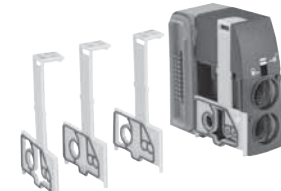

P2M2BXV0A

 Most popular.



For inventory, lead time, and kit lookup, visit www.pdnplu.com

"V" Series Valve Manifold with Collective Wiring
(Complete with Pneumatic Connectors)

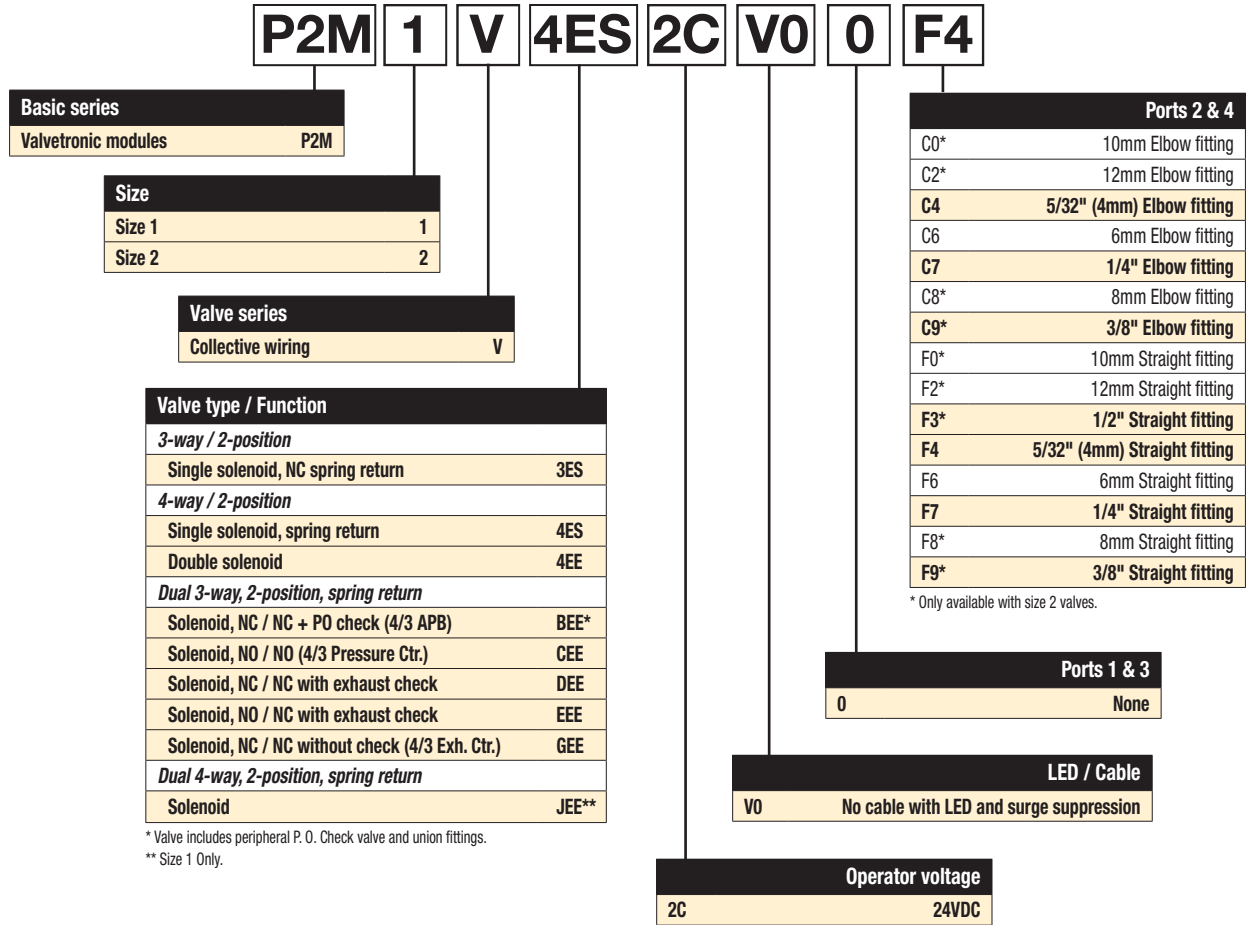

* Valve includes peripheral P. O. Check valve and union fittings.
 ** Size 1 Only.

D
 Subbase & Manual Valves
 H Series Micro
 Moduflex Series
 H Series ISO
 Fieldbus Systems
 DX ISOMAX Series
 Valvair II Series

With only one universal solenoid pilot for all configurations

24VDC is now a global standard for all machines. The Moduflex 24VDC unique solenoid pilot is supplied with the multi-function manual override that can be adapted to all requirements, as explained by the drawings.

Multi-function adaptable manual override

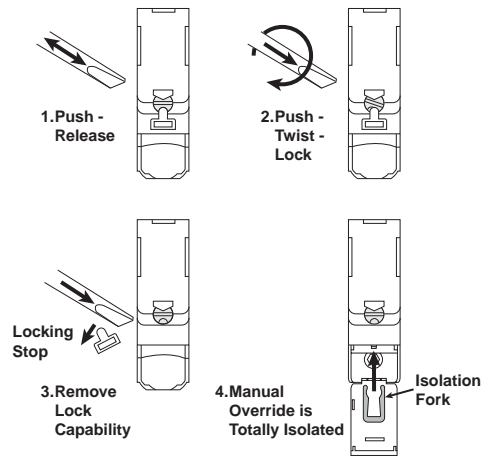

Most popular.



For inventory, lead times, and kit lookup, visit www.pdnplu.com

“V” Series Single Solenoid



How to Order -

Example: Size 1, 4-Way Single Solenoid valve with 1/4" Straight Connectors in Ports 2 and 4. Valve to include LED and surge suppression.

Line item	Quantity	Part number	Description
Complete Peripheral Module			
1	1	P2M2V4ES2CV00F7	Size 1, V Series Manifold Valves, 4 Way, Single Solenoid, LED / Surge Suppression, 1/4" OD Straight Port Fittings
Components			
1	1	P2M1V4ES2CV	Size 1, V Series Manifold Valves, Single Solenoid, 4 Way
2	2	FMD07-1B	Size 1, 1/4" OD Tube Push In Connector

D

Subbase & Manual Valves

H Series Micro

Moduflex Series

H Series ISO

Fieldbus Systems

DX ISOMAX Series

Valvair II Series



For inventory, lead time, and kit lookup, visit www.pdnplu.com

"V" Series 25-Pin, D-Sub Addressing



Valve Island Head 25-Pin, Multi-Connector

On the island head module, the multi-connector integrates the HE10 connector standard in its 25-Pin version.

Its plug-in function is secured in position with a guillotine lock with easy access from the front of the island.

The 25-Pin, D-Sub multi-connector is rated for IP40.

25-Pin, Multi-Connector Addressing

When assembling a **V Series** island, modules are automatically connected to the head module through the modular principle of the integrated electrical connections.

Each wire color code corresponds a solenoid pilot position in the island.



P8LMH25M3A - Cable

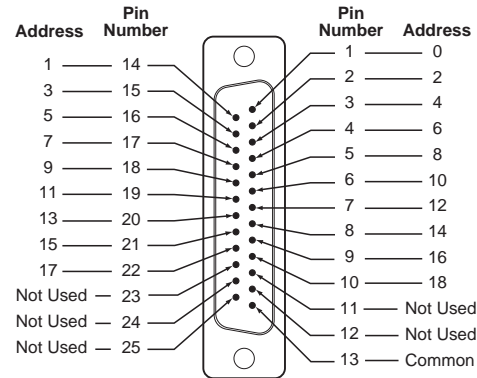

Face View - Male D-Sub, 25-Pin Head Module Connector

Electrical 25-Pin D-Sub Cable

Length (meters)	Weight (oz)	IP	Part number
3	14.3	20	P8LMH25M3A
3	14.3	65	SCD253W
9	55.8	20	SCD259D
9	55.8	65	SCD259WE

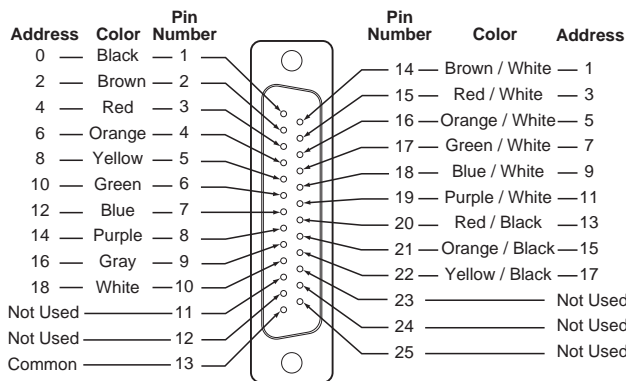

Face View - Female D-Sub, 25-Pin Cable Connector

Electrical Specifications

Rated voltage	24VDC
Maximum addresses	19
Maximum energized simultaneously	19
Electrical connection	25-Pin, D-Sub DIN41652, MIL-C-24308, NFC93425 Type HE5
Polarity	Insensitive: PNP and NPN compatible
Dust and water protection	IP40 / IP65



For inventory, lead times, and kit lookup, visit www.pdnplu.com

"V" Series 20-Pin, Multi-Connector and Addressing

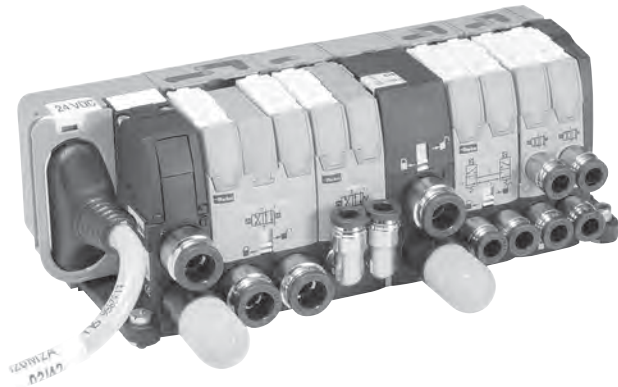

Valve Island Head 20-Pin, Multi-Connector

On the island head module, the multi-connector integrates the HE10 connector standard in its 20-Pin version.

Its plug-in function is secured in position with a guillotine lock with easy access from the front of the island.

Just like the whole island, the multi-connector follows the IP65 protection standard.

Cable Specification:

8.6 mm dia., UL, 20 wires, 0.22mm², AWG 24

Minimum Static Radius: 6.5 mm (.255")

Available with 6.56 ft. (2 m), 16.4 ft. (5 m) and 29.5 ft. (9 m) lengths.

20-Pin, Multi-Connector Addressing

When assembling a **V Series** island, modules are automatically connected to the head module through the modular principle of the integrated electrical connections.

The color code addressing given below conforms to the DIN 47100 standard.

Each wire color code corresponds a solenoid pilot position in the island.



P8LMH20M2A - Cable

Electrical 20-Pin Multi-Connector with Flying Lead Cable

Cable length	Weight (oz)	IP	Part number
2 m	10.97	65	P8LMH20M2A
5 m	27.41	65	P8LMH20M5A
9 m	49.38	65	P8LMH20M9A

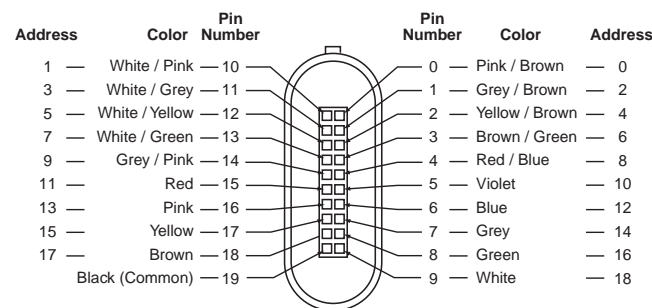

Face View - Female 20-Pin Cable Connector

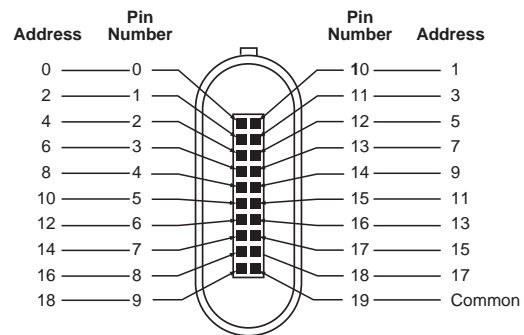

Face View - Male 20-Pin Head Module Connector

Electrical Specifications

Rated Voltage	24VDC
Maximum Addresses	19
Maximum Energized Simultaneously	19
Electrical Connection	Type HE10
Polarity	Insensitive: PNP and NPN compatible
Dust and Water Protection	IP65

D

Subbase & Manual Valves

H Series Micro

Moduflex Series

H Series ISO

Fieldbus Systems

DX ISOMAX Series

Valvair II Series



For inventory, lead time, and kit lookup, visit www.pdnplu.com

The Moduflex Fieldbus System

Moduflex communication modules directly attach to the Moduflex head set. It offers a compact and low cost fieldbus solution.

Features

- Small, compact product design
- IO-Link Type A & Type B communication modules
- Broad protocol offering, including DeviceNet, Profibus, AS-i, CANopen, and Interbus
- Channel-level diagnostics (LED and Electronic)
- Inputs available with AS-i modules
- Horizontal and vertical mounting without derating
- 5g vibration
- Quick-disconnects for I/O and network connectivity
- Built-in panel grounding
- CE certification

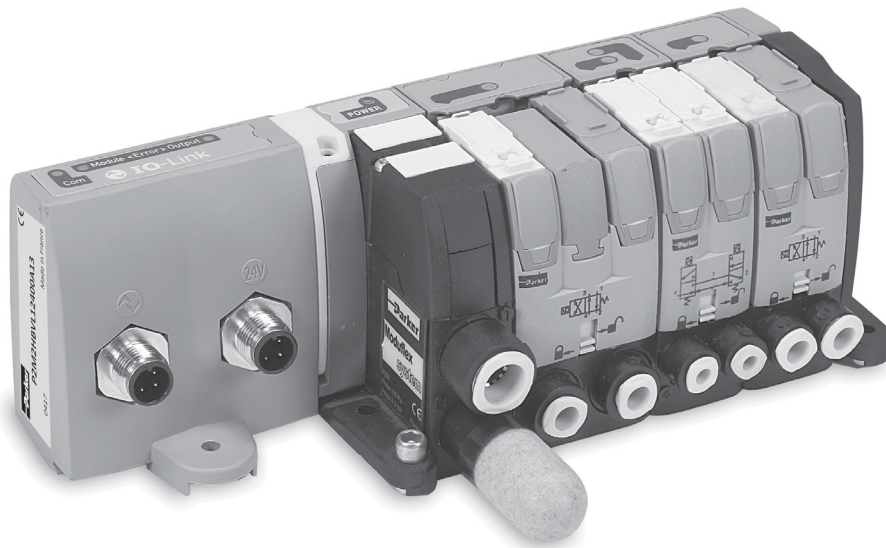

D

Subbase & Manual
Valves

H Series
Micro

Moduflex
Series

H Series
ISO

Fieldbus
Systems

DX ISOMAX
Series

Valvair II
Series



For inventory, lead times, and kit lookup, visit www.pdnplu.com

D48

Parker Hannifin Corporation
Pneumatic Division
Richland, Michigan
www.parker.com/pneumatics

“V” Series Valve Island
Electrical fieldbus head module for IO-Link

Electrical Module for 19 outputs (Moduflex Pilot Valves)
 (The last 5 outputs of this 24 DO module can't be used with Moduflex Valve)

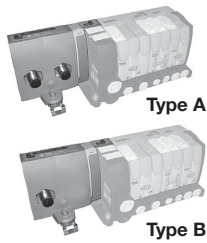

M12 A coded Connector connection						
Description	IO-Link Class	IO-Link	Aux. Power	Aux. Power Pinout	Weight (g)	Part number
Moduflex IO-Link Communication Module	Class A	3 Pin's	3 Pin's	1 & 3	160	P2M2HBVL12400A13
		3 Pin's	3 Pin's	4 & 3	160	P2M2HBVL12400A43
		3 Pin's	5 Pin's	4 & 2	160	P2M2HBVL12400A42
	Class B	5 Pin's		2 & 5	140	P2M2HBVL12400B25
Power & Communication Cable						RKC 4.5T*-RSC 4.5T/S1587

IODD file can be downloaded from IODD Finder or the Moduflex web site:
<https://ioddfinder.io-link.com> or www.parker.com/pdn/io-link

Where * = 1, 2, 3, 4, 5, 10, 20 meter standard lengths

Moduflex Class A module with independent Auxiliary Power Supply

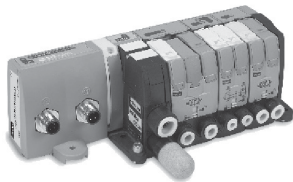

The Moduflex **IO-Link** Class A module can handle a Moduflex Valve bank having up to 19 pilot solenoid valves.

Thanks to its 2 x M12 A coded male connectors, it can be connected to any IO-Link Class A master and separately receive its auxiliary power supply for valves from an independent source.

The Moduflex **IO-Link** Class A module exists in 3 versions with the Auxiliary Power M12 connector pin out adapted to any sourcing through a standard M12 cable:

- P2M2HBVL12400A13 version: 24VDC / 0VDC on pins 1 & 3 – Standard version
- P2M2HBVL12400A43 version: 24VDC / 0VDC on pins 4 & 3 – Compatible with Siemens wiring
- P2M2HBVL12400A42 version: 24VDC / 0VDC on pins 4 & 2 – Compatible with Rockwell wiring and Turck

Moduflex Class B module

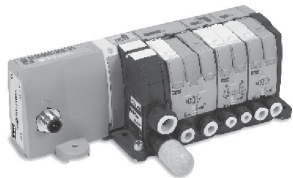

The Moduflex **IO-Link** Class B module can handle a Moduflex Valve bank having up to 19 pilot solenoid valves.

Thanks to its single M12 A coded male connectors, it can be connected to any IO-Link Class B master receiving its auxiliary power supply for valves on pins 2 & 5 from the only cable simplifying the connection.

- P2M2HBVL12400B25 version: 24VDC / 0VDC on pins 2 & 5

Diagnostic



The Moduflex **IO-Link** module offers a local diagnostic through 4 LED's located on the visible top side, showing:

- IO-Link com status
- Module error
- Output error
- Auxiliary power

Additional useful diagnostic information can be read by the PLC through the network simplifying diagnostic and allowing predictive maintenance (all details in the user manual).

 Most popular.

Auxiliary power for safe supply

The Moduflex **IO-Link** module is compatible with SAFE power source for valve control.

For more details, refer to next page.



For inventory, lead time, and kit lookup, visit www.pdnplu.com

D48a

Parker Hannifin Corporation
 Pneumatic Division
 Richland, Michigan
www.parker.com/pneumatics

D

Subbase & Manual Valves

H Series Micro

Moduflex Series

H Series ISO

Fieldbus Systems

DX ISOMAX Series

Valvair II Series

IO-Link module connection and diagnostic functions



IO-Link module connection

Standard male M12 – type A

Usage of standard manufactured cables available from your usual electrical supplier is recommended.

Note: Auxiliary power for solenoids can be wired allowing the user to turn outputs off while the communications remains on.

Configuration

IODD file can be downloaded from IODD Finder or the Moduflex web site:

<https://ioddfinder.io-link.com>
www.parker.com/pdn/io-link

Class B

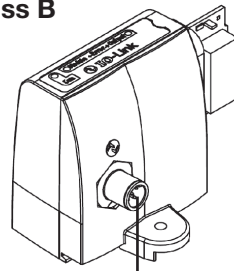

Class A

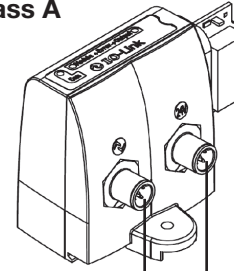

Legend

Symbol	Description
L+	IO-Link Power Supply "+"
L-	IO-Link Power Supply "-"
C/Q	IO-Link communication
Aux +	Auxilliary Power Supply 24 VDC
Aux -	Auxilliary Power Supply 0 VDC

M12 Pin's	Class A		
	3 Pin's		5 Pin's
	P2M...A13	P2M...A43	P2M...A42
1	Aux +	Not used	Not used
2	-	-	Aux -
3	Aux -	Aux -	Not used
4	n.c.	Aux +	Aux +
5	-	-	Not used

Auxiliary Power Supply Compatibility

The Moduflex IO-Link Module can be powered from a 24VDC auxilliary source in PP or PM mode as grounds are isolated.

For compatibility with a safe output pulsed module, please refer to user manual document available on www.parker.com/pdn/io-link

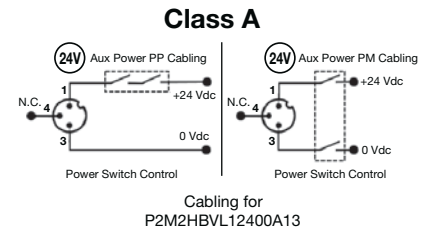
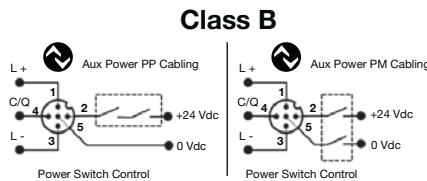

IO-Link module diagnostic functions

The Moduflex IO-Link module offers additional useful module status information:

- Solenoid overload or short circuit
- Auxiliary Voltage out of tolerance
- Cycle counter for each solenoid
- Module temperature

For more information on product technical information and module diagnostic functionalities, please refer to the User Manual available from the product web page:

www.parker.com/pdn/io-link

COM Green LED			Module — Error Red LED			Error — Output Red LED			POWER Green LED		
LED Status	Description	Solving	LED Status	Description	Solving	LED Status	Description	Solving	LED Status	Description	Solving
OFF	IO-Link L+ / L- not powered	Check connection	OFF	Standard mode	NA	OFF	Standard mode	NA	OFF	AUX power failure	Check Auxiliary Power Supply
ON	IOL L+ / L- powered IO mode	Set IO-Link mode in IO-Link master	ON	24 VDC AUX power missing or any active malfunction	Check power supply or change module	ON	Any driver error (overload, over temperature, etc.)	Fix solenoid issue then acknowledge error	ON	Standard	NA
Blinking	IO-Link communication active	NA							Blinking	Aux Power is out of range, alarm level	Check Auxiliary Power Supply

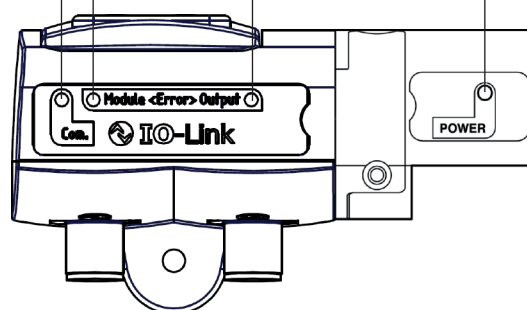

D48b



For inventory, lead times, and kit lookup, visit www.pdnplu.com

Parker Hannifin Corporation
 Pneumatic Division
 Richland, Michigan
www.parker.com/pneumatics

D
 Subbase & Manual
 Valves
 H Series
 Micro
 Moduflex
 Series
 H Series
 ISO
 Fieldbus
 Systems
 DX ISOMAX
 Series
 Valvair II
 Series

Input Data

One byte of diagnostic input data is transferred from Moduflex to the IO-Link Master.

Process Input Data

7	6	5	4	3	2	1	0
Output Driver SPI Error	Output Driver Channel Error	Polyfuse Tripped	Temperature Warning	SPI Error	AUX Voltage Error	AUX Voltage Warning	Acknowledge Required

Output Data

Three bytes of process data are received by Moduflex from the IO-Link Master for control of solenoids.

Process Output Data (Byte 0)

7	6	5	4	3	2	1	0
EV8	EV7	EV6	EV5	EV4	EV3	EV2	EV1

Process Output Data (Byte 1)

7	6	5	4	3	2	1	0
EV16	EV15	EV14	EV13	EV12	EV11	EV10	EV9

Process Output Data (Byte 2)

7	6	5	4	3	2	1	0
EV24	EV23	EV22	EV21	EV20	EV19	EV18	EV17

Solenoid Pilots Addressing And Process Mapping

IO-Link Module addressing used with Moduflex Valve System

The Moduflex IO-Link module used with Moduflex Valve System can handle up to 19 pilot solenoid valves. Addressing will be done as shown below.

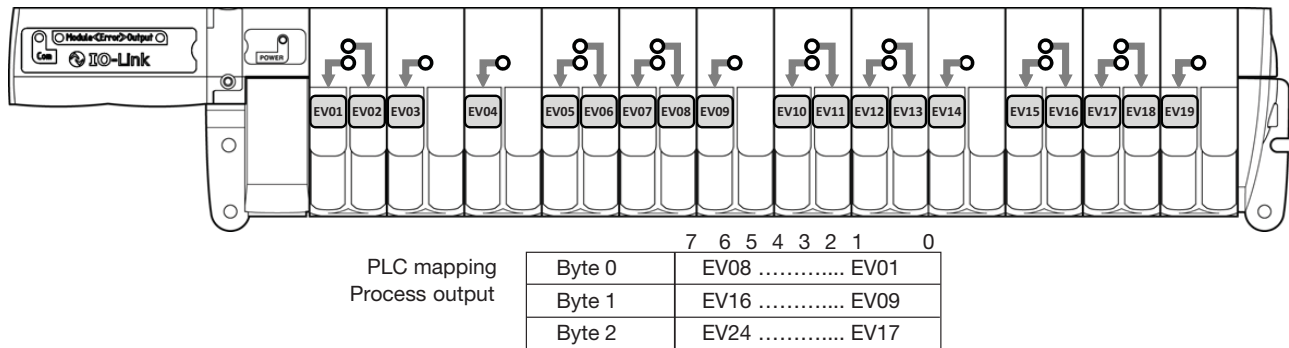

IO-Link Module Electrical Specifications

IO-Link Power Supply	According to IO-Link standard V1.1.2
Speed Communication	Com 2 – 38 kBd
Auxiliary Power Supply	20.4 VDC to 26.4 VDC
Current Limit per channel	150 mA
Max Current Limit	4 A
Polarity inversion	YES
Short Circuit Protection	YES
Operating Temperature	0°C to 55°C
Storage Temperature	-25°C to 70°C
Shock According to IEC	60068-2-27:2008
Vibration According to IEC	60068-2-6:2007
EMC According to IEC	61000-4-2 up to -4-6

Network diagnostic through Process mapping:

The Moduflex IO-Link module offers diagnostic data transmitted to the PLC through the master:

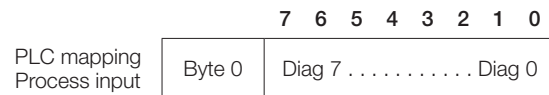

Diag bit	Error message	Detail
Diag 0.....	Fail-safe status	Acknowledgment required
Diag 1.....	Auxiliary voltage warning.....	Check auxiliary power
Diag 2.....	Auxiliary voltage failure.....	Check auxiliary power
Diag 3.....	Module failure	Module HS. must be replaced
Diag 4.....	Module over-temperature	
Diag 5.....	Module over-load	
Diag 6.....	Pilot Solenoid(s) short circuit	Solenoid must be replaced
Diag 7.....	Outputs stage failure	

For further details, refer to the User Manual: Can be downloaded from www.parker.com/pdn/io-link



For inventory, lead time, and kit lookup, visit www.pdnplu.com

D48c

Parker Hannifin Corporation
 Pneumatic Division
 Richland, Michigan
www.parker.com/pneumatics

D

Subbase & Manual Valves

H Series Micro

Moduflex Series

H Series ISO

Fieldbus Systems

DX ISOMAX Series

Valvair II Series

“V” Series Fieldbus Connections

Valve Island Electrical Head Modules for Bus Connections and Control



CANopen



INTERBUS-S

Device Bus Electrical Head Modules

Electrical Module for 16 Outputs Max.
 (V Series islands may have up to 16 solenoids)



P2M2HBVP11600

Moduflex Communication Modules

Bus protocol	Weight	Part number
Profibus DP	8.82	P2M2HBVP21600
DeviceNet	8.82	P2M2HBVD21600
CANopen	8.82	P2M2HBVC21600
InterBus-S	10.58	P2M2HBVS11600

Fieldbus Accessories

	Bus protocol	Connector type	Weight (oz)	Part number
Power supply female straight field wireable connector	Profibus DP / InterBus-S / DeviceNet / CANopen	M12 type A	0.88	P8CS1205AA
Line termination resistor	Profibus DP	M12 type B	0.88	P8BPA00MB
	DeviceNet / CANopen	M12 type A	0.88	P8BPA00MA

Note: Use standard cables and connectors for bus communications from your electrical supplier.

M12 (Male) Power Supply Connector

- 1 - 24VDC Module (Not Connected for DeviceNet and CANopen)
- 2 - Not Connected
- 3 - 0VDC Module and Solenoid
- 4 - 24VDC Solenoid
- 5 - Protected Earth (PE)

Profibus DP / DeviceNet / CANopen / InterBus-S

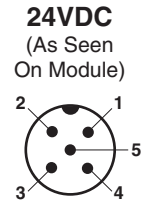

M12 Male Type A

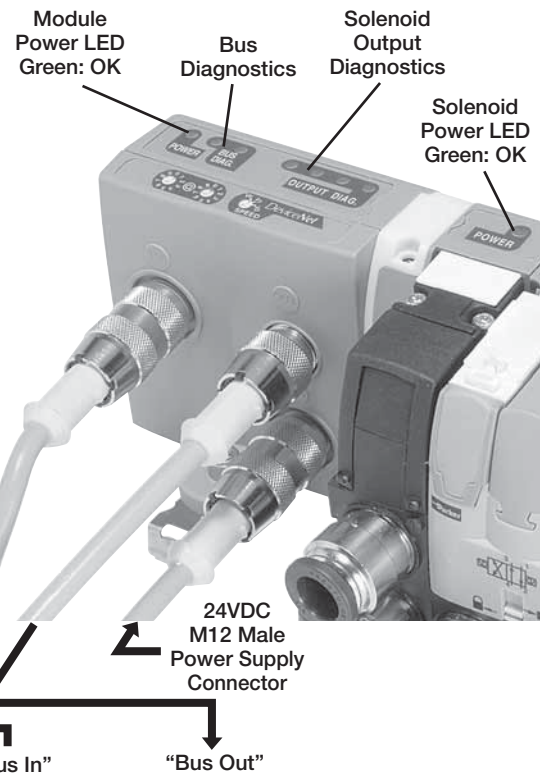

Connection

All bus modules have an M12 male connector for power supply.

Connector on Moduflex Modules are labeled. Bus Connectors are labeled “Bus In” and “Bus Out” while, Power Supply Connections are labeled “24VDC”. Connect Fieldbus to “Bus In” and “Bus Out” and Power Supply to “24VDC”.

Diagnostic

The two “power” indicators shown on the illustrations provide visual indication of the module and solenoid supply status.

Note: Output power to the solenoids can be wired to allow the user to turn the outputs off while allowing communications to remain on. This can be done by placing the user's Emergency Stop switch or other hard-wired control contact between Pin 1 and Pin 4. If this feature is not required, Pin 1 and Pin 4 should be wired together.



For inventory, lead time, and kit lookup, visit www.pdnplu.com

“V” Series Valvetronic™
Device Bus Module: Connections, Addressing, Diagnostic



Bus Cable Connections

Profibus DP standard male and female type B M12 connectors.

Use of prefabricated cables available from your local electrical supplier is recommended.

Line termination P8BPA00MB, is necessary on the “bus out” connector of the last station.

This module incorporates an Autobaud detect feature, eliminating the need to set switches.

Bus In
 (As Seen On Module)

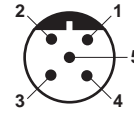

M12 Male Type B

Pin Out	
1	+ 5V
2	Line A
3	0V
4	Line B
5	Shield

Bus Out
 (As Seen On Module)

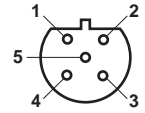

M12 Female Type B

Addressing

Use the GSD file on web site.

The rotary switches enable configuration of the decimal address.

Diagnostic

Diagnostic according to the module dialog shown on the illustration.

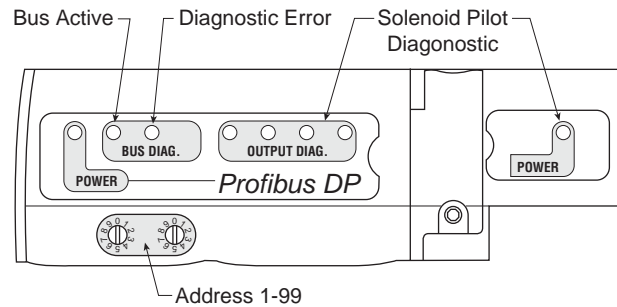

Bus Cable Connections

DeviceNet standard male and female type A M12 connectors.

Use of prefabricated cables available from your local electrical supplier is recommended.

Line termination P8BPA00MA, is necessary on the “bus out” connector of the last station.

Bus In
 (As Seen On Module)

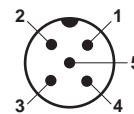

M12 Male Type A

Pin Out	
1	Drain
2	24VDC
3	0VDC
4	CAN-H
5	CAN-L

Bus Out
 (As Seen On Module)

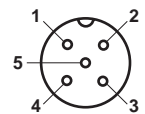

M12 Female Type A

Addressing

Use the EDS file on web site.

The rotary switches enable configuration of the node address (MAC ID) and the baud rate.

Diagnostic

Diagnostic according to the module dialog shown on the illustration.

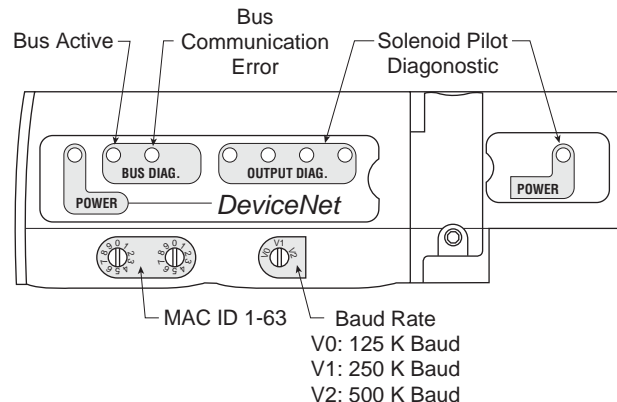

D
 Subbase & Manual Valves
 H Series Micro
 Moduflex Series
 H Series ISO
 Fieldbus Systems
 DX ISOMAX Series
 Valvair II Series



For inventory, lead times, and kit lookup, visit www.pdnplu.com

CANopen

Bus Cable Connections

CANopen standard male and female type A M12 connectors.

Use of prefabricated cables available from your local electrical supplier is recommended.

Line termination P8BPA00MA, is necessary on the “bus out” connector of the last station.

Addressing

Use the EDS file on web site.

The rotary switches enable configuration of the decimal address.

Diagnostic

Diagnostic according to the module dialog shown on the illustration.

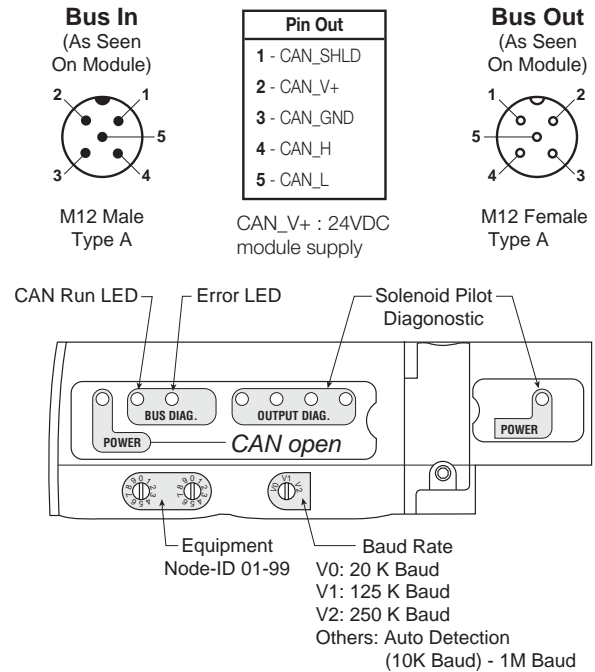

INTERBUS-S

Bus Cable Connections

The M23 connectors conform to “Interbus remote bus”.

Use of prefabricated cables available from your usual electrical supplier is recommended.

This module operates at 500 kbps.

Addressing

InterBus-S is self addressing; therefore, it does not need any software or hardware configuration.

Diagnostic

Diagnostic according to the module dialog shown on the illustration.

This diagnostic conforms to the InterBus-S standard.

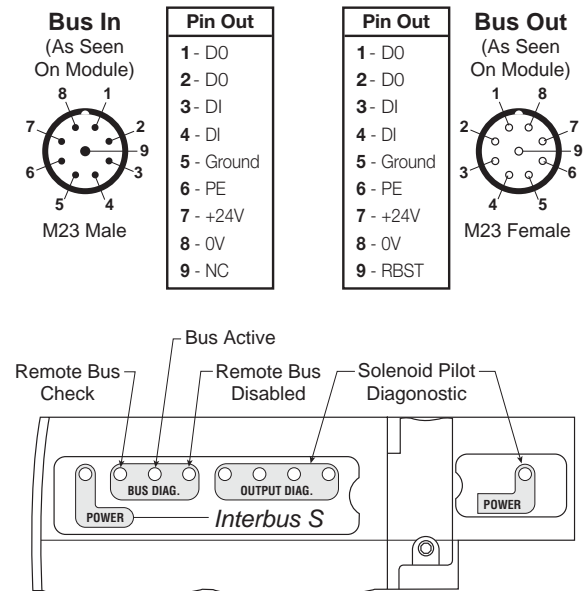

Note: For more details, please consult “Interbus remote bus” documentation.

"V" Series Bus Connections Modules

Valve Island Electrical Head Modules for Bus Connections and Control



P2M2HBVA10808A



P2M2HBVA10808B



P2M2HBVA10800

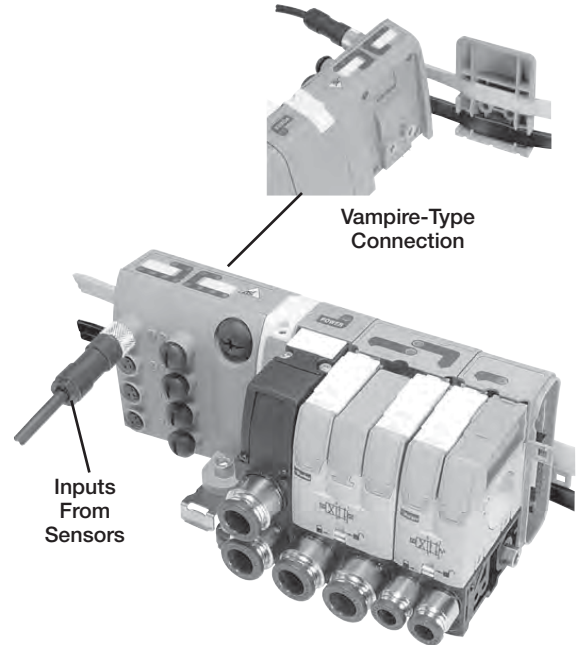

Vampire-Type Connection

Inputs From Sensors

**Standard AS-i Protocol (up to 31 nodes)
 Electrical Head Modules**

Electrical Module for 8 Solenoids Max.
 (V Series islands may have up to 8 solenoids)
 (2 nodes per module, 4 inputs, 4 solenoids per node)

Input / output capability	Weight (oz)	Part number
0 inputs and 8 solenoid outputs	5.29	P2M2HBVA10800
8 (PNP) inputs on eight (M8) connectors and 8 solenoid outputs	7.05	P2M2HBVA10808A
8 (PNP) inputs on four (M12) connectors and 8 solenoid outputs	7.05	P2M2HBVA10808B

**AS-i Version 2.1 Protocol (up to 62 nodes)
 Electrical Head Modules**

Electrical Module for 6 Solenoids Max.
 (V Series islands may have up to 6 solenoids)
 (2 nodes per module, 4 inputs, 3 solenoids per node)

Input / output capability	Weight (oz)	Part number
0 inputs and 6 solenoid outputs	5.29	P2M2HBVA20600
8 (PNP) inputs on eight (M8) connectors and 6 solenoid outputs	7.05	P2M2HBVA20608A
8 (PNP) inputs on four (M12) connectors and 6 solenoid outputs	7.05	P2M2HBVA20608B

AS-i Bus Accessories

M12 Cable with Jack for Addressing

Length	Weight (oz)	Part Number
1 m	3.53	P8LS12JACK

Most popular.

D
 Subbase & Manual Valves
 H Series Micro
 Moduflex Series
 H Series ISO
 Fieldbus Systems
 DX ISOMAX Series
 Valvair II Series



For inventory, lead times, and kit lookup, visit www.pdnplu.com

AS-i Bus Communication Module: Addressing, Diagnostic, Input Wiring
Bus Addressing, First and Second Node

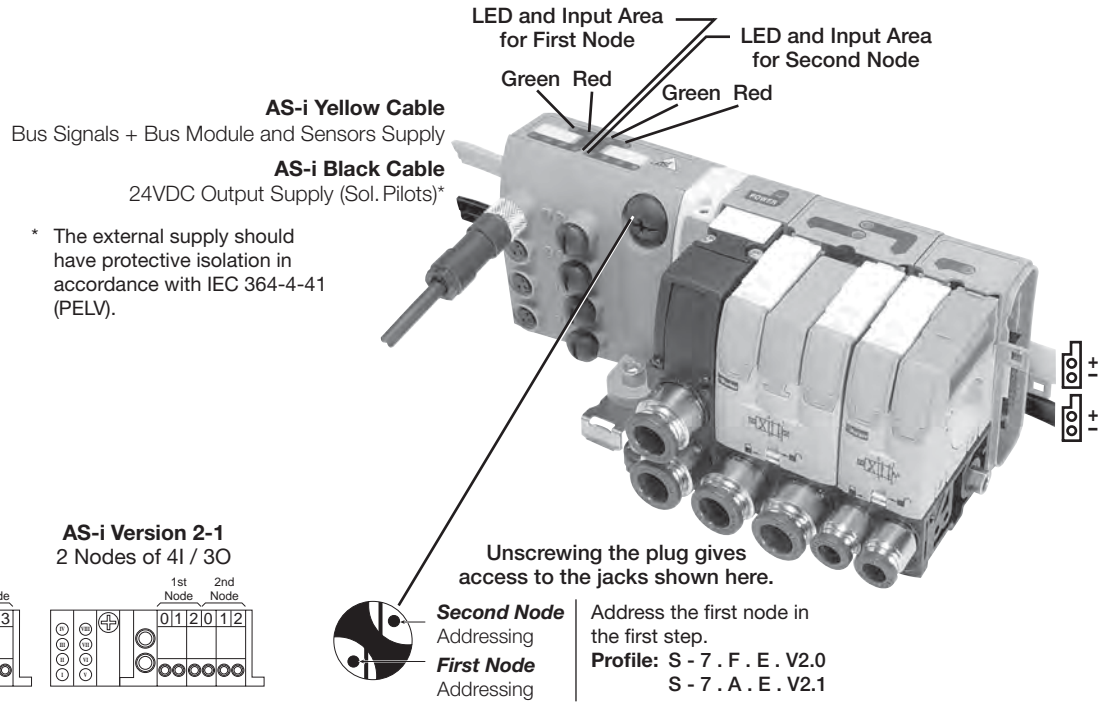

AS-i Yellow Cable
 Bus Signals + Bus Module and Sensors Supply

AS-i Black Cable
 24VDC Output Supply (Sol. Pilots)*

* The external supply should have protective isolation in accordance with IEC 364-4-41 (PELV).

LED and Input Area for First Node
 Green Red
 LED and Input Area for Second Node
 Green Red

Unscrewing the plug gives access to the jacks shown here.

Second Node
 Addressing

First Node
 Addressing

Profile: S - 7 . F . E . V2.0
 S - 7 . A . E . V2.1

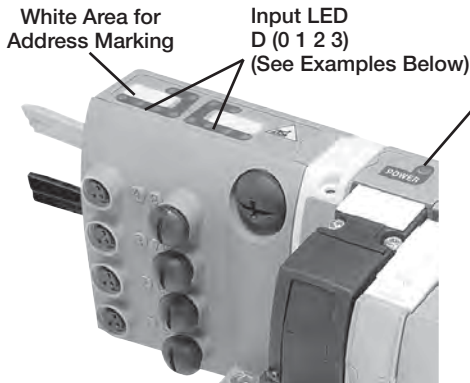
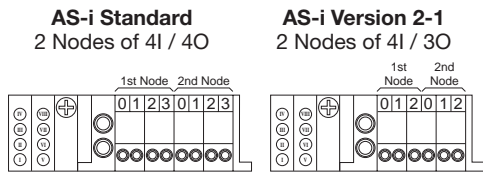

Bus Diagnostic

"Power" LED State		Off	Green	Red	
Power Supply		Sol. Pilot Supply	Normal Operation	Solenoid Overload	
First Node LEDs State		Second Node LEDs State		System Condition	
Green LED	Red LED	Green LED	Red LED		
★	○	★	○	Normal Operation	
○	○	○	○	No Module + Sensor Supply	
○	⚙	○	⚙	Input Overload	
○	★	○	⚙	No AS-i Communication	
⚙	★	○	⚙	Address First Node = 0	
★	○	⚙	★	Address Second Node = 0	

★ON ○OFF ⚙BLINK

Input Wiring

Physical Input (I, II, III, IV) = D (0 1 2 3) First Node,
 Physical Input (V, VI, VII, VIII) = D (0 1 2 3) Second Node.

Examples: Physical Input III = Logical Input 6.2,
 Physical Input V = Logical Input 7.0.

M8 Female Connectors

Pin Out

- 1 - 24VDC / AS-i
- 3 - 0VDC / AS-i
- 4 - Input

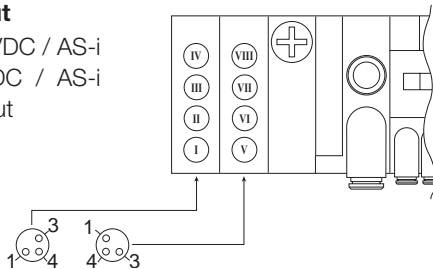

M12 Female Connectors

Pin Out

- 1 - 24VDC / AS-i
- 2 - Second Input
- 3 - 0VDC / AS-i
- 4 - First Input
- 5 - Not Connected

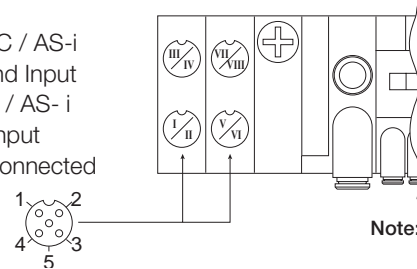

Note: With only one node, the inputs II and IV are connected to the connections on the right.



For inventory, lead time, and kit lookup, visit www.pdnplu.com

Solenoid Pilot Diagnostic Common to All Device Bus Modules

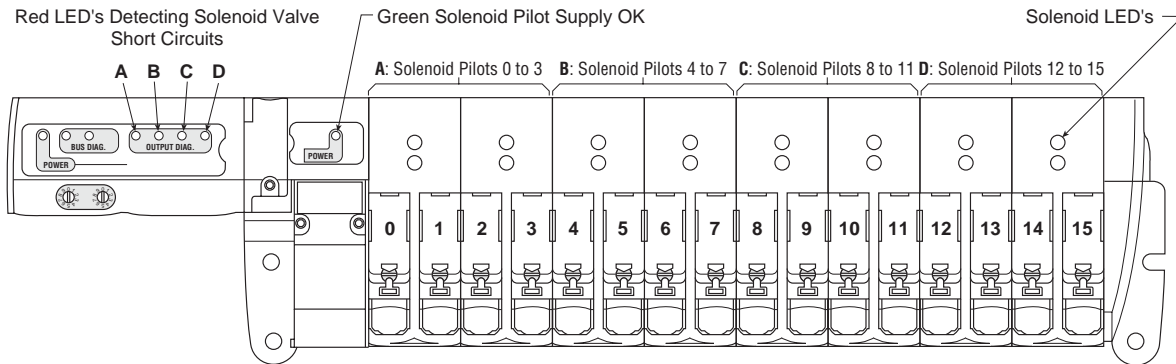

Inside the communication module, solenoid valve control is protected against short-circuits with the following visual indication provided:

- The red LEDs with code, shown above, detect solenoid valve short-circuits.
- Supply is OK when the solenoid pilot power supply indicator is green.

D
 Subbase & Manual Valves
 H Series Micro
 Moduflex Series
 H Series ISO
 Fieldbus Systems
 DX ISOMAX Series
 Valvair II Series

Bus Cable Protection

Shield Connections for Profibus DP, DeviceNet and CANopen

To provide protection against electro-magnetic interferences, the bus cables are shielded. The “bus in” and “bus out” connectors each include a pin for connecting the cable shield. It is safer to connect the shield to the protected earth (PE) at both ends of the bus. Within the communication module, provision is made to enable shield continuity by connecting the two shield pins.

The protected earth must be connected locally on each module for CE accordance.

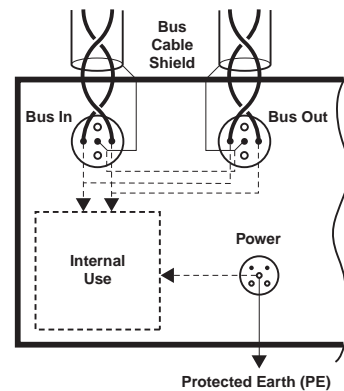

For inventory, lead times, and kit lookup, visit www.pdnplu.com

Serial Bus Specifications

All Buses	EMC / CE Mark	According to EN 61 000-6-2	EN 50081-2		
	AS-i Line	According to EN 50295			
AS-i Bus	Solenoid Pilot Voltage	24VDC			
	Module Consumption	max. 70 mA (2 nodes)			
	Max. Supply for All Inputs	240 mA (including internal input consumption)			
	Internal Input Consump.	9 mA for each active input			
	Inputs	According to IEC 1131-2 class 2			
	Certification	These products have been developed according to the association complete specification (v.2.11) and to the slave profiles S-7.FE or S-B.FE			
Device Bus	Bus Line	According to each bus specification			
	Module Voltage	20 to 30VDC			
	Solenoid Pilot Voltage	24VDC			
	Module Consumption	Profibus DP max. 1.5W	DeviceNet / CANopen max. 1.5W	InterBus-S max. 2W	
	Outputs	Overload protection			
	Certification	DeviceNet: Compliant to Composite Test Revision 17, Test Suite: M002			
		Profibus-DP: Compliant to Test Specifications for Profibus DP Slaves, Version 2.0, February 2000, based on EN 50170-2 at Siemens AG in Furth.			
InterBus-S: This product has passed the relevant tests in accordance with the Interbus conformance requirements Certified No. 385.					

I/O Tables Common to All Device Bus Modules

Input Data Table

Byte	Bit 0	Bit 1	Bit 2	Bit 3	Bit 4	Bit 5	Bit 6	Bit 7
0	Discrete Input 0 (Diagnostic LED 0-3)	Discrete Input 1 (Diagnostic LED 4-7)	Discrete Input 2 (Diagnostic LED 8-11)	Discrete Input 3 (Diagnostic LED 12-15)	—	—	—	—

Output Data Table

Byte	Bit 0	Bit 1	Bit 2	Bit 3	Bit 4	Bit 5	Bit 6	Bit 7
0	Discrete Output 0	Discrete Output 1	Discrete Output 2	Discrete Output 3	Discrete Output 4	Discrete Output 5	Discrete Output 6	Discrete Output 7
1	Discrete Output 8	Discrete Output 9	Discrete Output 10	Discrete Output 11	Discrete Output 12	Discrete Output 13	Discrete Output 14	Discrete Output 15

D

Subbase & Manual Valves

H Series Micro

Moduflex Series

H Series ISO

Fieldbus Systems

DX ISOMAX Series

Valvair II Series









For inventory, lead time, and kit lookup, visit www.pdnplu.com

D55

Parker Hannifin Corporation
 Pneumatic Division
 Richland, Michigan
www.parker.com/pneumatics

Peripheral Modules

Accessories	Description	Option	Part number		
			Size 1	Size 2	
	Pressure regulator without gauge	0 to 30 PSI	P2M1PXST	P2M2PXST	
		0 to 60 PSI	P2M1PXSL	P2M2PXSL	
		0 to 120 PSI	P2M1PXSN	P2M2PXSN	
	Pressure regulator with gauge	0 to 30 PSI	P2M1PXSR	P2M2PXSR	
		0 to 60 PSI	P2M1PXSM	P2M2PXSM	
		0 to 120 PSI	P2M1PXSG	P2M2PXSG	
	Gauge	0 to 30 PSI	P2M1K0GT	P2M1K0GT	
		0 to 60 PSI	P2M1K0GL	P2M1K0GL	
		0 to 120 PSI	P2M1K0GN	P2M1K0GN	
	Push to connect fitting	5/32" or 4mm OD tube	Elbow	CMD04-1	
			Straight	FMD04-1	
		1/4" OD tube	Elbow	CMD07-1B	CMD07-2B
			Straight	FMD07-1B	FMD07-2B
		3/8" OD tube	Elbow		CMD09-2B
			Straight		FMD09-2B
		1/2" OD tube	Straight		FMD13-2B
			6mm OD tube	Elbow	CMD06-1
		8mm OD tube	Straight	FMD06-1	FMD06-2
			Elbow		CMD08-2
		10mm OD tube	Straight		FMD08-2
			Elbow		CMD10-2
12mm OD tube	Straight		FMD10-2		
	Elbow		CMD12-2		
	Double male union	Connecting peripheral modules		HMDXX1	HMDXX2
				MMDVA1	MMDVA2
	Muffler for vacuum exhaust port			PMDYY1	PMDYY2
	Plug				

Note: 85 Durometer minimum for pneumatic connectors.

D

Subbase & Manual Valves

H Series Micro

Moduflex Series

H Series ISO

Fieldbus Systems

DX ISOMAX Series

Valvair II Series



For inventory, lead times, and kit lookup, visit www.pdnplu.com

Dual P.O. Check Valve

Combined with a double 3/2 NC + NC valve, this module will block both flows and stop cylinder movement as soon as the valve's outputs are both exhausted. Better than a 3-Position valve, it provides more precise positioning when fitted close to the cylinder. Standard with manual release buttons.

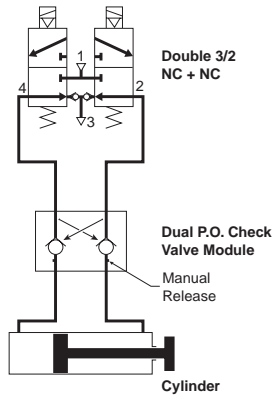

P2M1PXCA

Application

At the outputs of a double 3/2 NC + NC valve, the dual P.O. check valve module achieves efficient and stable cylinder positioning. As soon as both lines are exhausted by the main control valve, the two internally piloted check valves close tight. The cylinder is then stabilized.

The manual pressure releases may then eventually be used for an adequate machine positioning.

Dual P.O. Check Valve

	Part number
Size 1	P2M1PXCA
Size 2	P2M2PXCA

Dual Flow Control

By controlling the exhaust flows of a double-acting cylinder, this module can adjust both speeds — extend and retract. It may be plugged into the valve module output ports or mounted close to the cylinder in its in-line version.

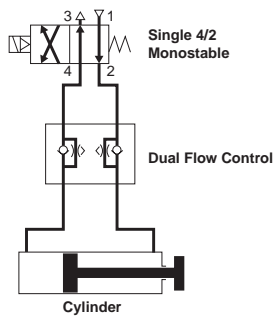

P2M1PXFA

Application

On a double-acting cylinder, extend and retract speeds are adjusted separately by control of air flow exhaust. The control becomes more precise when the flow adjustment is close to the cylinder. The examples show different solutions which are dependent upon the valve-to-cylinder distance and accessibility to the cylinder

Dual Flow Control Module

	Weight	Part number
Size 1	1.06 oz	P2M1PXFA
Size 2	1.59 oz	P2M2PXFA



For inventory, lead time, and kit lookup, visit www.pdnplu.com

“P” Series Peripheral Modules Model Number Index
(Complete with Pneumatic Connectors)

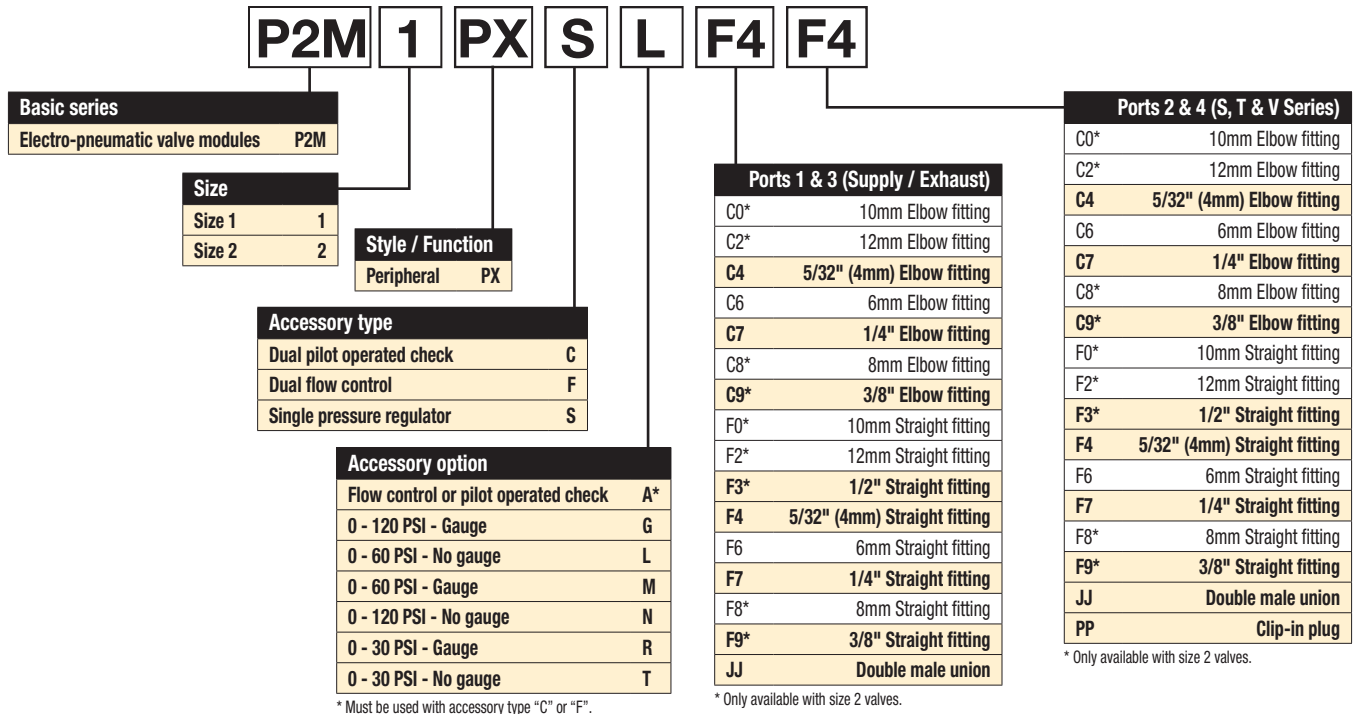

D
Subbase & Manual Valves
H Series Micro
Moduflex Series
H Series ISO
Fieldbus Systems
DX ISOMAX Series
Valvair II Series

Regulator with Gauge



How to Order - Example: Size 1, Regulator with gauge, 1/4" OD straight fittings.

Line item	Quantity	Part number	Description
Complete Peripheral Module			
1	1	P2M1PXSGF7F7	Size 1, Regulator with 0-160 PSI Gauge, 1/4" OD Straight Port Fittings in port 1, 2, 3, 4
Components			
1	1	P2M1PXSG	Size 1, Regulator with 0-160 PSI Gauge
2	4	FMD07-1B	Size 1-1/4" OD Tube Push-In Connector

Flow Control with Fittings



How to Order - Example: Size 1, Dual Flow Control, 1/4" OD straight fittings.

Line item	Quantity	Part number	Description
Complete Peripheral Module			
1	1	P2M1PXFAF7F7	Size 1, Dual Flow Control, 1/4" OD Straight Port Fittings in Port 1, 2, 3, 4
Components			
1	1	P2M1PXFA	Size 1, Dual Flow Control
2	4	FMD07-1B	Size 1-1/4" OD Tube Push-In Connector



For inventory, lead times, and kit lookup, visit www.pdnplu.com

Vacuum Generator Applications

Depending on the application requirements, this vacuum generator may be controlled by single or by a dual 3/2 Moduflex valve. The Vacuum Generator has an integrated blow-off chamber that helps destroy the degree of vacuum. Blow-off can be increased with the addition of a control air input to the blow-off port on the vacuum module. A Ø6 mm port is available for an optional plug-in vacuum sensor for delivering a vacuum feedback signal.



Description	Weight	Size
Vacuum Generator	.88 oz	P2M1PXVA

Single 3/2 NC Air Control Valve

The 3/2 valve delivers the air supply to generate vacuum through the venturi. It also pressurizes the integrated blow-off chamber. When the 3/2 valve cuts-off the air supply, this chamber is automatically exhausted into the vacuum channel in order to speed-up the part release. In this type of application, it is preferred to have the vacuum generator mounted away from the control valve.

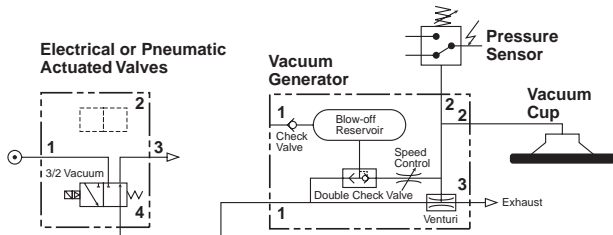

Dual 3/2 3/2 Valve Control

One 3/2 valve controls air supply for vacuum. The other 3/2 valve will generate an additional blow-off that may prove necessary to obtain quick part release from large vacuum pads. The effect of the blow-off can be controlled with an adjustable screw. In this type of circuit, the Vacuum Generator can be mounted directly to the valve by using Double Male Unions or as a stand alone item away from the control valve.

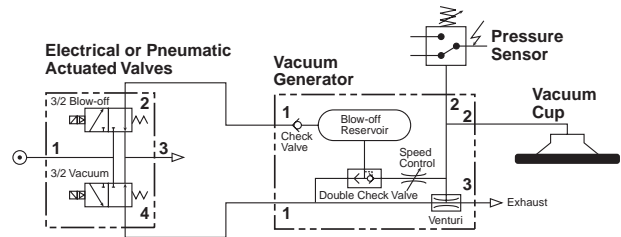

Vacuum Flow (SCFM)

Nozzle Diameter	0	3	6	9	12	15	18	21	24	27	30
P2M1PXVA	0.84	0.76	0.67	0.55	0.42	0.30	0.18	0.06	—	—	—

Evacuation Time

Series / Nozzle Diameter	Air supply pressure	Air consumption	Evacuation time in sec / ft ³ * to reach different vacuum levels (inHg)								
	PSI	SCFM	3	6	9	12	15	18	21	24	27
P2M1PXVA	70	1.60	5.6	14.2	22.0	42.4	62.3	85.0	116	198	—

* 1 ft³ = 28.31 liters

Vacuum Generator Model Number Index

P2M1PXVA F7 A F7 C MA

Basic configuration	Basic unit	P2M1PXVA
----------------------------	------------	----------

#1 Pressure port		
5/32" (4mm) elbow	C4	
6mm elbow	C6	
1/4" Elbow	C7	
Joint fitting	JJ	
5/32" (4mm) straight	F4	
6mm straight	F6	
1/4" Straight	F7	

Port #1 configuration		
Fitting in pressure port and blow-off port	A	
Fitting in pressure port and blow-off port plugged*	B	

#2 Sensor port		
A	6mm Plug	
B	Plug	
K	1/4" Straight	
L	1/4" Elbow	
M	6mm Elbow	

#2 Vacuum port		
C4	5/32" (4mm) Elbow	
C6	6mm Elbow	
C7	1/4" Elbow	
F4	5/32" (4mm) Straight	
F6	6mm Straight	
F7	1/4" Straight	

#3 Exhaust port		
C4	5/32" (4mm) Elbow	
C6	6mm Elbow	
C7	1/4" Elbow	
F4	5/32" (4mm) Straight	
F6	6mm Straight	
F7	1/4" Straight	
MA	Muffler	

* Can not be directly mounting to valve.



For inventory, lead time, and kit lookup, visit www.pdnplu.com

Intermediate Supply Module Model Number Index

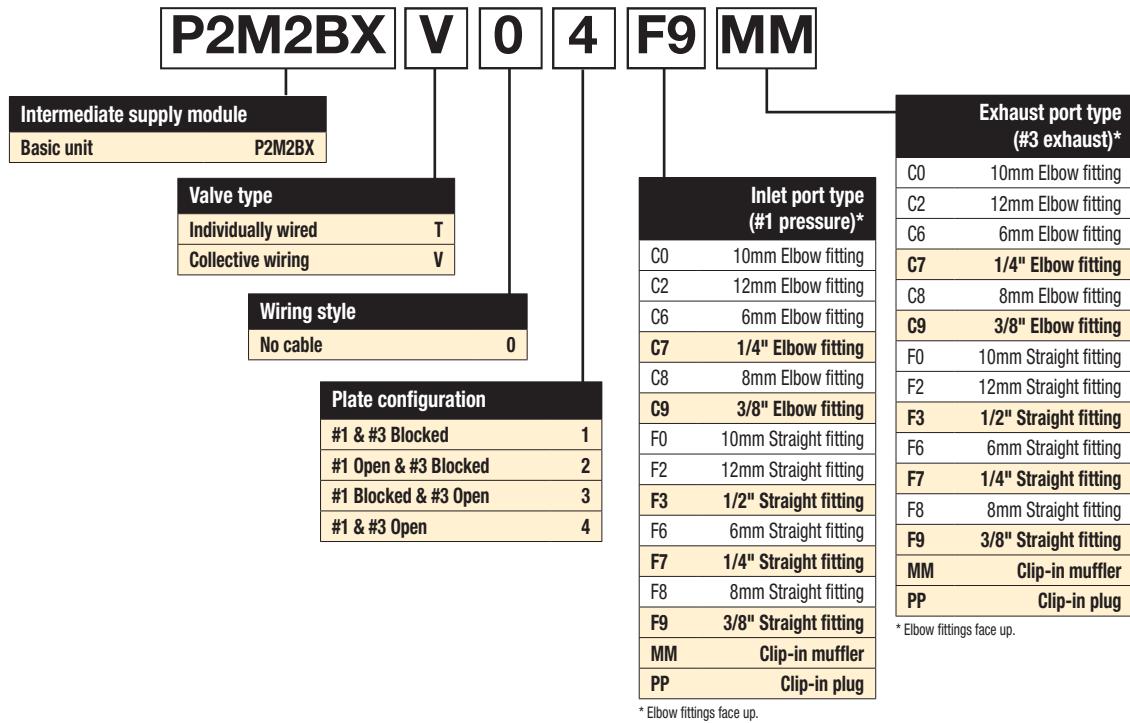

D
 Subbase & Manual Valves
 H Series Micro
 Moduflex Series
 H Series ISO
 Fieldbus Systems
 DX ISOMAX Series
 Valvair II Series

Plate Configuration



#1 & #3 Blocked

#1 Port connected to valves on the right only. Left is blocked.
#3 Port connected to valves on the right only. Left is blocked.



#1 Open, #3 Blocked

#1 Port connected to valves on the right and the left.
#3 Port connected to valves on the right only. Left is blocked.



#1 Blocked, #3 Open

#1 Port connected to valves on the right only. Left is blocked.
#3 Port connected to valves on the right and the left.



#1 & #3 Open

#1 Port connected to valves on the right and the left.
#3 Port connected to valves on the right and the left.



For inventory, lead times, and kit lookup, visit www.pdnplu.com

D60

Parker Hannifin Corporation
Pneumatic Division
Richland, Michigan
www.parker.com/pneumatics

Solenoid Pilot 24VDC

Description	Part number
Solenoid pilot (without plug-in electrical connector)	P2D8V32C5
Air pilot with 5/32" (4mm) tube fitting	P2M2K0PA
Solenoid pilot (without clip connector)	P2D2W3226C5



P2D2W3226C5



P2D8V32C5



P2M2K0PA

**Size 1 Valve
 Without Solenoid Pilot
 and Without Subbase
 4-way / 2-position / Single Valve**



P2M1X4EE

Solenoid	Part number
Single solenoid (Monostable)	P2M1X4ES
Double solenoid (Bistable)	P2M1X4EE

4-way / 2-position / Dual Valve

Solenoid	Part number
Solenoid spring with exhaust check	P2M1XJEE

3-way / 2-position / Dual Valve

Solenoid	Part number
Double solenoid NC + NC with exhaust check	P2M1XDDE
Double solenoid NO + NO with exhaust check	P2M1XCEE
Double solenoid NC + NO with exhaust check	P2M1XEEE
Single solenoid NC with exhaust check	P2M1X3ES

Set of Maintenance Parts

Description	Part number
Clips Set of 10 clips: 6 for size 1 valves, 2 for size 2 valves, 2 for end plate and intermediate modules	P2M2K0CA
Seals Set of 10 seals: 3 for manifold to manifold seals, 3 under solenoid pilot seals, 4 under valve seals (two size 1 seals, two size 2 seals)	P2M2K0JA
Forks Set of 10 isolation forks for solenoid pilot manual override	P2M2K0FA

**Size 2 Valve
 Without Solenoid Pilot
 and Without Subbase
 4-way / 2-position / Dual Valve**



P2M2X4EE

Solenoid	Part number
Single solenoid (Monostable)	P2M2X4ES
Double solenoid (Bistable)	P2M2X4EE

3-way / 2-position / Dual Valve

Solenoid	Part number
Double solenoid NC + NC with exhaust check	P2M2XDDE
Double solenoid NO + NO with exhaust check	P2M2XCEE
Double solenoid NC + NO with exhaust check	P2M2XEEE
Single solenoid NC with exhaust check	P2M2X3ES

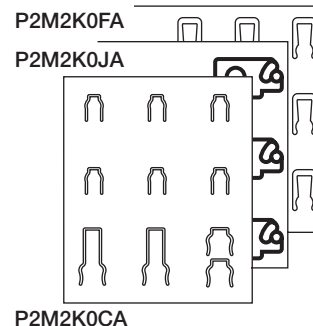

For inventory, lead time, and kit lookup, visit www.pdnplu.com

D61

Parker Hannifin Corporation
 Pneumatic Division
 Richland, Michigan
www.parker.com/pneumatics

D

Subbase & Manual Valves

H Series Micro

Moduflex Series

H Series ISO

Fieldbus Systems

DX ISOMAX Series

Valvair II Series

Moduflex Add-A-Fold Assembly Model Number Index
(Complete with Pneumatic and Electrical Connectors)

How To Order Plug-in Add-A-Fold Assemblies

1. List Add-A-Fold Assembly call out. This automatically includes the end plate kit assembly.
2. List valves and manifolds. List left to right, LOOKING AT THE CYLINDER PORTS on the manifold.

P2MA V 0 1 C9 C9 ##

Moduflex island assembly	
Add-A-Fold	P2MA*

*Includes pneumatic H & T end plate kit.

Style	
Individually wired	T
Collective wiring	V*

* Includes 20-pin multi-connector or 25-pin, D-sub electrical head module.

Wiring / Bus protocol	
No cable (20-pin or multi-connector T series)	0 †
2 Meter cable (20-pin)	2
5 Meter cable (20-pin)	5
9 Meter cable (20-pin)	9
Bus	B*
No cable (25-pin, D-sub)	D
3 Meter cable (25-pin, D-sub)	F

* Order bus module as a separate line item.
 † Default to option "0" for T series.

Pilot source	
Internal supply / Internal exhaust	1
Internal supply / External exhaust	2
External supply / Internal exhaust	3
External supply / External exhaust	4

Number of stations ^f	
01 - 19*	V-Type
01 - 30	T-Type

* Max. number of addresses for V type is 19. Single solenoid valves equal one address. Double solenoid valves equal two addresses. Maximum address may depend upon choice of bus protocol.

† Intermediate modules are considered stations, but do not count against maximum number of addresses for manifold.

Exhaust port type (#3 Exhaust)*	
C0	10mm Elbow fitting
C2	12mm Elbow fitting
C6	6mm Elbow fitting
C7	1/4" Elbow fitting
C8	8mm Elbow fitting
C9	3/8" Elbow fitting
F0	10mm Straight fitting
F2	12mm Straight fitting
F3	1/2" Straight fitting
F6	6mm Straight fitting
F7	1/4" Straight fitting
F8	8mm Straight fitting
F9	3/8" Straight fitting
MM	Clip-in muffler
PP	Clip-in plug

* Elbow fittings face up.

Inlet port type (#1 pressure)*	
C0	10mm Elbow fitting
C2	12mm Elbow fitting
C6	6mm Elbow fitting
C7	1/4" Elbow fitting
C8	8mm Elbow fitting
C9	3/8" Elbow fitting
F0	10mm Straight fitting
F2	12mm Straight fitting
F3	1/2" Straight fitting
F6	6mm Straight fitting
F7	1/4" Straight fitting
F8	8mm Straight fitting
F9	3/8" Straight fitting
MM	Clip-in muffler
PP	Clip-in plug

* Elbow fittings face up.

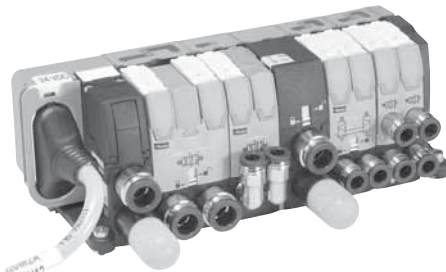

"V" Series with 20-pin Connector



"V" Series with Field Bus Connection

D
 Subbase & Manual Valves
 H Series Micro
 Moduflex Series
 H Series ISO
 Fieldbus Systems
 DX ISOMAX Series
 Valvair II Series



For inventory, lead times, and kit lookup, visit www.pdnplu.com

How to Order -

Example: Application requires V Series valves with 20-Pin, D-Sub and 2 Meter cable. Manifold to include (1) Size 2, 4/2 Double Solenoid Valve - 3/8" OD fitting, (1) Size 1, 4/2 Single Solenoid Valve - 1/4" OD Elbow Fitting, Intermediate Module - 3/8" OD Fitting with Exhaust Muffler, Port 1 and 3 Blocked, (1) Size 1, Dual 3/2 NC Valve and (1) Size 1, 4-Way Double Solenoid Valve both with 1/4" OD Straight Fittings. Includes 3/8 OD Inlet Fitting and Exhaust Muffler.

Line item	Quantity	Part number	Description
Complete Manifold Assembly			
1	1	P2MAV21F9MM05	Moduflex Island Assembly, Pneumatic Head and Tail Module Set, Internal Pilot Supply, Internal Pilot Exhaust, 3/8" Straight Fitting Port 1, Port 3 Muffler.
2	1	P2M2V4EE2CV00F9	Size 2, Double Solenoid, 4/2, 3/8" Straight Pneumatic Connectors.
3	1	P2M1V4ES2CV00C7	Size 1, Single Solenoid, 1/4" Elbow Pneumatic Connectors.
4	1	P2M2BXV0A1F9MM	Intermediate Module 3/8" Straight Fitting with Exhaust Muffler
5	1	P2M1VDEE2CV00C7	Size 1, Dual 3/2 NC + NC, 1/4" Elbow Pneumatic Connectors.
6	2	P2M1VJEE2CV00F7	Size 1, Dual 4/2, 1/4" Straight Pneumatic Connectors.

Components

1	1	P2M2HXT01	Pneumatic Head and Tail Module Set
2	1	P2M2HEV0A	20-Pin, Multi-Connector Electrical Head Module
3	1	P8LMH20M2A	2 Meter, 20-Pin Cable
4	1	P2M2V4EE2CV	Size 2, V Series Island Valve Module, Double Solenoid, 4-Way
5	1	P2M1V4ES2CV	Size 1, V Series Island Valve Module, Single Solenoid, 4-Way
6	1	P2M2BXV0A	Intermediate Module
7	1	P2M1VGEE2CV	Size 1, V Series Island Valve Module, Dual 3/2 NC + NC
8	2	P2M1VJEE2CV	Size 1, V Series Island Valve Module, Dual 4/2
9	2	CMD07-1B	Size 1, 1/4" OD Tube Elbow Push-in Connector
10	6	FMD07-1B	Size 1, 1/4" OD Tube Straight Push-in Connector
11	4	FMD09-2B	Size 2, 3/8" OD Tube Straight Push-in Connector
12	2	MMDVA2	Clip-on Muffler

How to Order -

Example: Application requires V Series valves with DeviceNet Communications Module. Manifold to include (1) Size 2, 4/2 Double Solenoid Valve - 3/8" OD fitting, (1) Size 1, 4/2 Single Solenoid Valve - 1/4" OD Elbow Fitting, Intermediate Module - 3/8" OD fitting with Exhaust Muffler, Port 1 and 3 Blocked, (1) Size 1, Dual 3/2 NC Valve and (1) Size 1, 4-Way Double Solenoid Valve both with 1/4" OD Straight Fittings. Include 3/8 OD Inlet Fitting and Exhaust Muffler.

Line item	Quantity	Part number	Description
Complete Manifold Assembly			
1	1	P2MAVB1F9MM05	Moduflex Island Assembly, Pneumatic Head and Tail Module Set, Internal Pilot Supply, Internal Pilot Exhaust, 3/8" Straight Fitting Port 1, Port 3 Muffler.
2	1	P2M2HBVD11600	DeviceNet Module
3	1	P2M2V4EE2CV00F9	Size 2, Double Solenoid, 4/2, 3/8" Straight Pneumatic Connectors.
4	1	P2M1V4ES2CV00C7	Size 1, Single Solenoid, 1/4" Elbow Pneumatic Connectors.
5	1	P2M2BXV0A1F9MM	Intermediate Module 3/8" Straight Fitting with Exhaust Muffler
6	2	P2M1VDEE2CV00C7	Size 1, Dual 3/2 NC + NC, 1/4" Elbow Pneumatic Connectors.
7	1	P2M1VJEE2CV00F7	Size 1, Dual 4/2, 1/4" Straight Pneumatic Connectors.

Components

1	1	P2M2HXT01	Pneumatic Head and Tail Module Set
2	1	P2M2HBVD11600	DeviceNet Module
3	1	P2M2V4EE2CV	Size 2, V Series Island Valve Module, Double Solenoid, 4-Way
4	1	P2M1V4ES2CV	Size 1, V Series Island Valve Module, Single Solenoid, 4-Way
5	1	P2M2BXV0A	Intermediate Module
6	1	P2M1VGEE2CV	Size 1, V Series Island Valve Module, Dual 3/2 NC + NC
7	2	P2M1VJEE2CV	Size 1, V Series Island Valve Module, Dual 4/2
8	2	CMD07-1B	Size 1, 1/4" OD Tube Elbow Push-in Connector
9	6	FMD07-1B	Size 1, 1/4" OD Tube Straight Push-in Connector
10	4	FMD09-2B	Size 2, 3/8" OD Tube Straight Push-in Connector
11	2	MMDVA2	Clip-on Muffler



For inventory, lead time, and kit lookup, visit www.pdnplu.com

D63

Parker Hannifin Corporation
 Pneumatic Division
 Richland, Michigan
www.parker.com/pneumatics

D

Subbase & Manual Valves

H Series Micro

Moduflex Series

H Series ISO

Fieldbus Systems

DX ISOMAX Series

Valvair II Series

Internal and external pilot supply options

All T and V Series Valve bases incorporate an auxiliary channel “X” to supply pressure to the solenoid pilots. The “X” galley is pressurized from the left hand end plate. Depending on the configuration of the left hand end plate, this pressure is either supplied from the #1 port in the left hand end plate or supplied externally through a 4mm OD tube fitting in the left hand end plate. This fitting is supplied in all left hand end plates and can be converted in the field.

Internal and external solenoid pilot exhaust options

All T and V Series Valve bases incorporate an auxiliary channel “E” which is used to exhaust the solenoid pilot pressure from each solenoid valve. The “E” galley is connected to the left hand end plate. Depending on the configuration of the left hand end plate, this exhaust is either connected to the #3 exhaust port or is connected to a 4mm OD Tube fitting in the left hand end plate. This fitting is supplied in all left hand end plates and can be converted in the field.

To configure the left hand end plate, with pressure off, remove head cover to expose the selector section. Loosen selector section and rotate “X” or “E” channel selector to desired position. Tighten selector section and assemble cover.

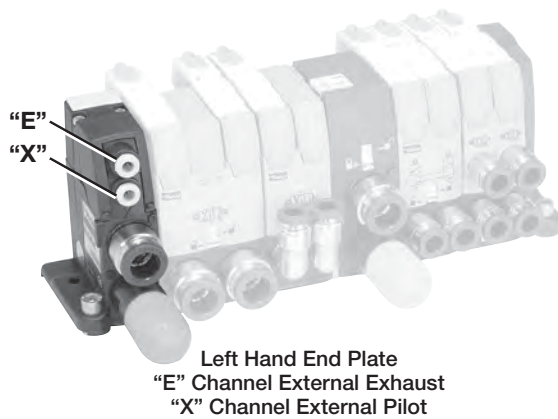
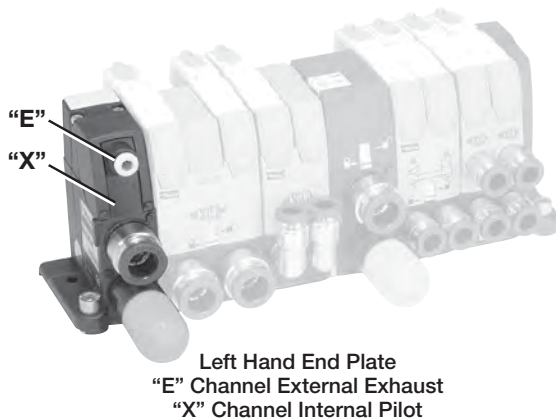
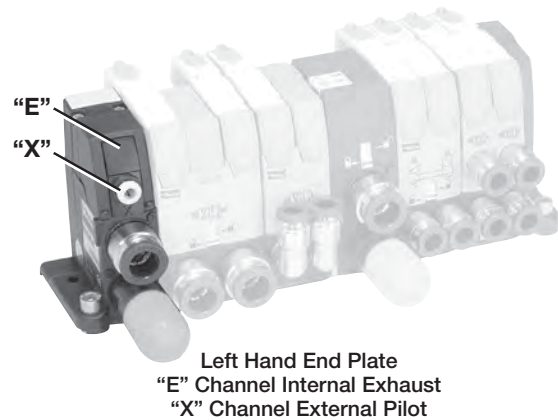
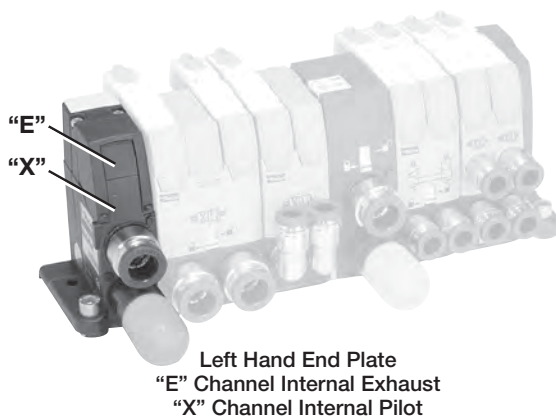
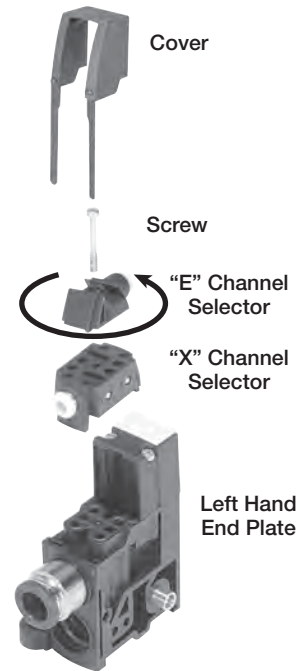

D	Subbase & Manual Valves
	H Series Micro
Moduflex Series	
H Series ISO	
Fieldbus Systems	
DX ISOMAX Series	
Valvair II Series	



For inventory, lead times, and kit lookup, visit www.pdnplu.com

“V”, “T” and “S” Series Maintenance

The latest generations of compact pneumatic valves have a life expectancy which generally exceeds the equipment they control. Therefore, maintenance is seldom required. When it

is necessary to change the solenoid pilot, valve or connector, they can be easily replaced without removing the island base, as shown below.

“S” Series

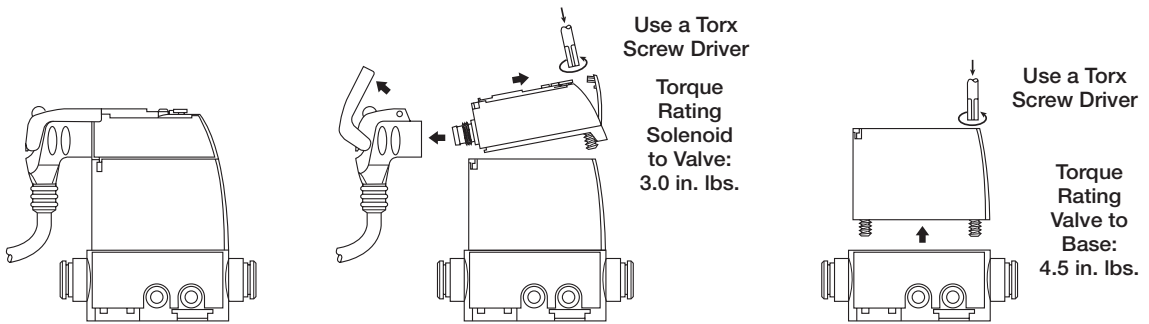

“T” Series

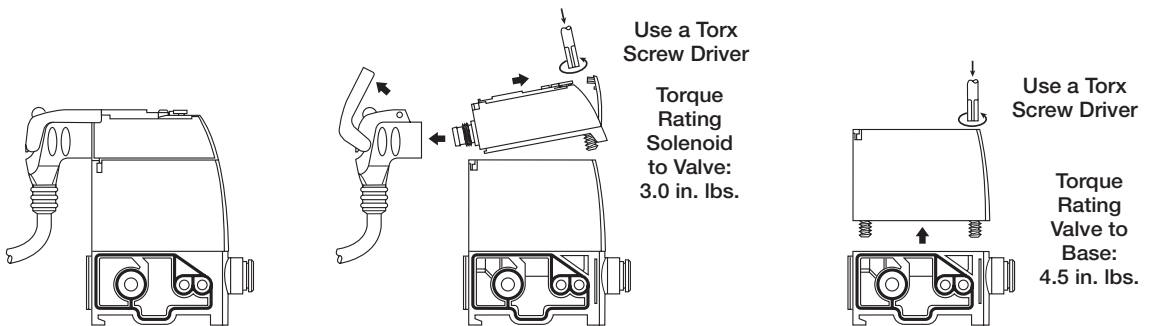

“V” Series

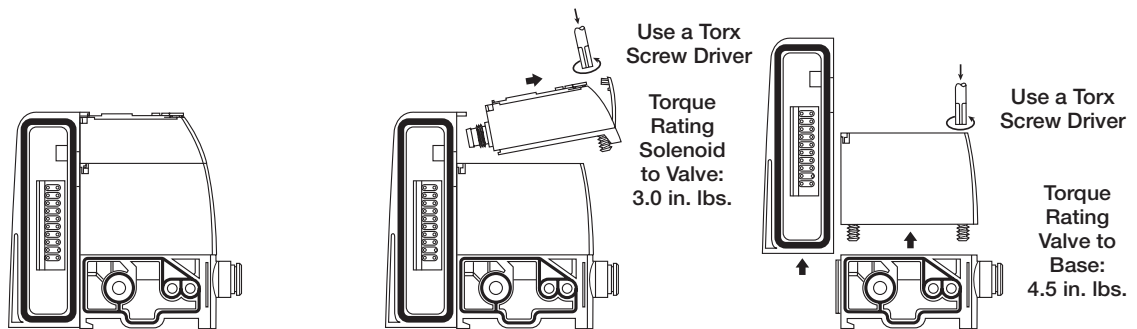

Fitting and Tubing Installation

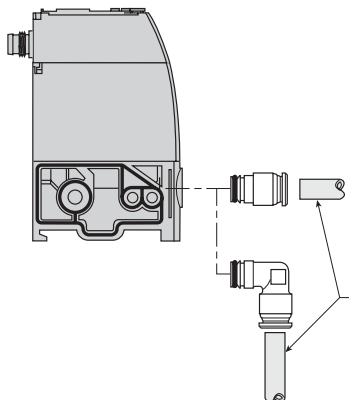

Fitting Assembly: Pneumatic Connectors are retained by a clip in each module. Assembly is achieved by pushing the fitting into the module and sliding the clip down over the groove in the fitting. Pull fitting to check that it is secure.

Tubing Assembly: Cut tubing squarely & cleanly. Inspect the tubing to insure there are no sharp edges that may nick or cut the o-ring seal. Insert tubing into fitting until it bottoms out. A slight pull on the tube afterwards can help verify it is properly retained / inserted.

Tubing Disassembly: When it is required to remove the tubing from the fitting push the release button in towards the fitting & remove the tubing.

Tubing Reassembly: Inspect the tubing before re-inserting it for any scoring or other damage that would affect the o-ring sealing. It is recommended that for every insertion, the tubing end be trimmed, especially if it has any scoring or damage.

Pneumatic Valve Specifications

Fluid	Air, inert gas, filtered 40µ ¹ , dry ² or lubricated ³		
Operating Pressures	Vacuum to 120 PSI		
Piloting Pressure	43 to 120 PSI for operating pressures below, use external pilot supply available on all head modules ⁵		
Pilot Supply	Internal with "S" Series, mixed internal / external with "T" and "V" Series		
Exhaust Collection	All exhausts are collectable, including solenoid pilot exhaust		
Life Cycle	100 million operations ⁴ (with dry air, 3 Hz, 20°C, 6 bar)		
Operating Temperatures	5°F to 140°F (32°F to 130°F for field bus systems)		
Stocking Temperatures	-40°F to 155°F		
Vibration Resistance	According to IEC 68 - 2 - 6	2G	2 to 150 Hz
Impact Resistance	According to IEC 68 - 2 - 27	15G	11 ms

1. Class 5 according to ISO 8573-1
2. Class 4 according to ISO 8573-1
3. 3. With main air supply lubricated, monitor lubrication rate so that valve bank is not flooded with lubricant.
4. 4/2 valve
5. Double 3/2 minimum 50 PSI

Electrical Specifications

Rated Coil Voltage	24VDC		
Allowable Voltage Fluctuation	-15% to +10 % of nominal voltage		
Electrical Connection	Polarity insensitive: PNP and NPN compatible		
Coil insulation Type	Class B		
Power Consumption	1W (42 mA)		
Manual Override	Locking or non-locking, isolated if required		
Response Time of the Complete Valve	9.6 ms ± 1.2 on 4/2 Double Solenoid Valve Size 1 12.0 ms ± 1.2 on 4/2 Single Solenoid Valve Size 1 14.8 ms ± 2 on 4/2 Double Solenoid Valve Size 2 17.0 ms ± 2 on 4/2 Single Solenoid Valve Size 2	According to ISO 12238	
Type of Use	Continuous-duty Solenoid		
Dust and Water Protection	According to EN 60 529	"S" and "T" Series:	M8 IP67
			Clip IP40
		"V" Series:	IP65

Specifications

1/4", 3/8" and 1/2" Fittings

Construction

Nickel Plated Brass Body; O-ring: Nitrile (Buna N) lubricated with Silicone lubricant; Grab Ring: 301 Stainless Steel; One Piece Button Collet: Acetal – black

Recommended Parker Tubing Series:

E (Linear Low Density Polyethylene), PP (Polypropylene), N (Plasticized Polyamide, Nylon), NR (Unplasticized Polyamide, Rigid Nylon), U (Polyurethane 90 Durometer Shore A), HU (Polyurethane 95 Durometer Shore A)

Other materials: Polyurethane 85 Durometer Shore A – Applications and service conditions vary and therefore the use of a tube support may be required for any 85A PU tubing. The following commercially available O.D. – I.D. 85A tubing sizes require the use of a tube support regardless of application. (5/32" – 3/32", 3/16" – 1/8", 1/4" - .170", 1/4" – 3/16", 5/16" – 1/4", 3/8" – 5/16", 1/2" – 3/8")

Prestolok fittings should not be used for live swivel applications. Vacuum applications dependent upon temperature and type of tubing used.

6mm, 8mm, 10mm, 12mm Fittings

Construction

Polyamide HR Body; O-ring: Nitrile (Buna N) lubricated with Silicone lubricant; Sleeve: Nickel Plate Brass; Grab Ring: 301 Stainless Steel; One Piece Button Collet: Polyacetal – yellow

Recommended Parker Tubing Series for 6mm, 8mm, 10mm, 12mm Fittings:

E (Linear Low Density Polyethylene), N (Plasticized Polyamide, Nylon), U (Polyurethane 90 Durometer Shore A), HU (Polyurethane 95 Durometer Shore A)

Prestolok fittings should not be used for live swivel applications. Vacuum applications dependent upon temperature and type of tubing used.

D
 Subbase & Manual Valves
 H Series Micro
 Moduflex Series
 H Series ISO
 Fieldbus Systems
 DX ISOMAX Series
 Valvair II Series



For inventory, lead times, and kit lookup, visit www.pdnplu.com

D66

Parker Hannifin Corporation
 Pneumatic Division
 Richland, Michigan
www.parker.com/pneumatics

"S" Series Individual Subbase Valve Dimensions and Mounting

Subbase Valve Size 1



Subbase Valve Size 2



Surface Mounting with Screws 4 mm Dia. into Retractable Brackets 3mm Thick

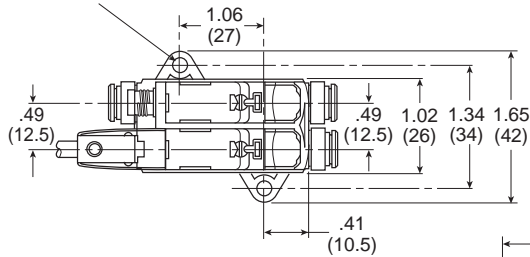

Surface Mounting with Screws 4 mm Dia. into Retractable Brackets 3mm Thick

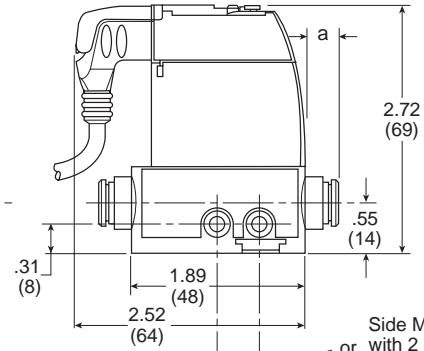
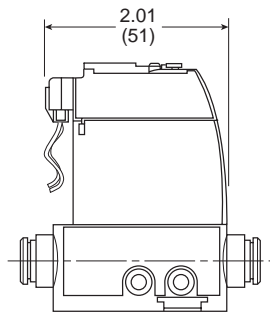
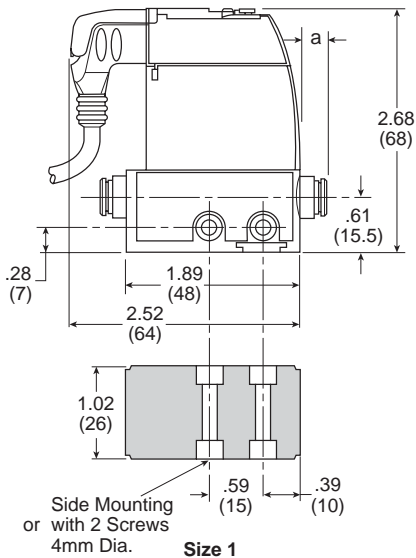
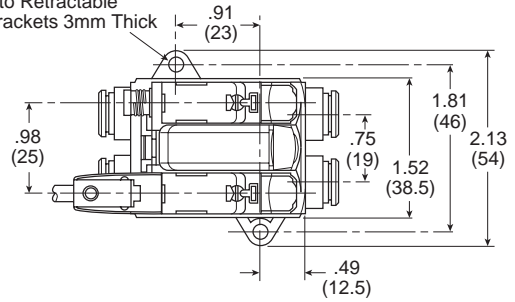

Side Mounting with 2 Screws 4mm Dia. or

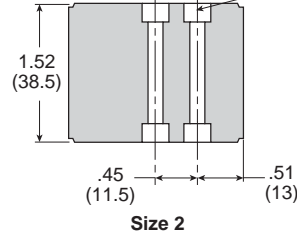

Air Pilot

OD Tube Ext.	a	b	c
5/32" (4 mm)	8	10	12
Size 1 Valves			
6 mm	8	13	16
1/4"	15	18	22
Muffler		31	
1/4"	12	18	22
Size 2 Valves			
8 mm	9	16	19
3/8"	16	23	26
10 mm	13	18	22
Muffler		40	

Special Case: 4/3 all ports blocked. Add the dual P.O. check valve that has been plugged in the basic valve.

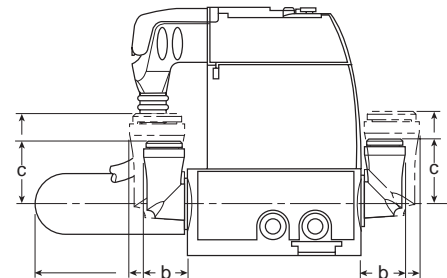

For inventory, lead time, and kit lookup, visit www.pdnplu.com

D67

Parker Hannifin Corporation
 Pneumatic Division
 Richland, Michigan
www.parker.com/pneumatics

D

Subbase & Manual Valves

H Series Micro

Moduflex Series

H Series ISO

Fieldbus Systems

DX ISOMAX Series

Valvair II Series

"T" Series Manifold Dimensions and Mounting



Total Width Depends
 on Valve Composition

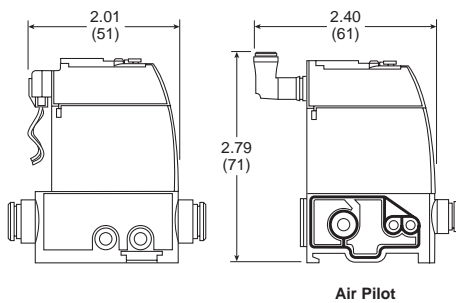
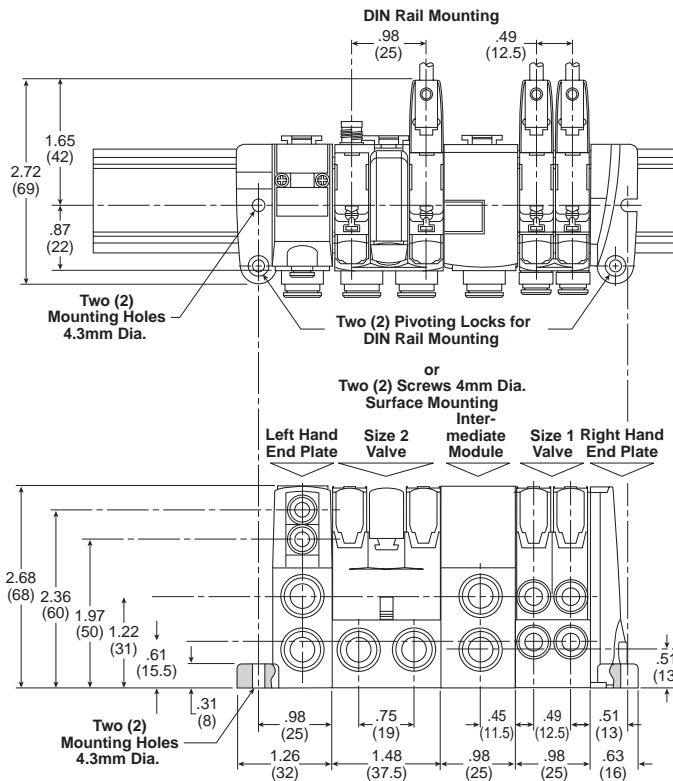
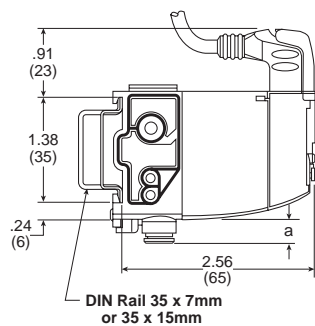

Special Case: 4/3 all ports blocked function within island version, add the dimensions of the dual P.O. check valve plugged into the island.

End Plate and Intermediate Modules

	a	b	c
6 mm Tube OD	8	13	16
1/4" Tube OD	12	18	22
8 mm Tube OD	9	16	19
3/8" Tube OD	16	23	26
10 mm Tube OD	13	18	25
12 mm Tube OD	13	19	25
1/2" Tube OD	13		
Muffler	40		

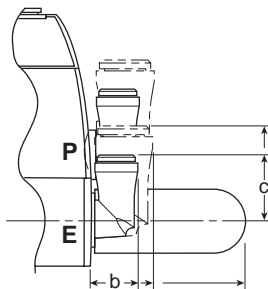

OD Tube	Ext.	a	b	c
Size 1 Valves	5/32" (4 mm)	8	10	12
	6 mm	8	13	16
Size 2 Valves	1/4"	15	18	22
	1/4"	12	18	22
	8 mm	9	16	19
	3/8"	16	23	26
10 mm	13	18	22	

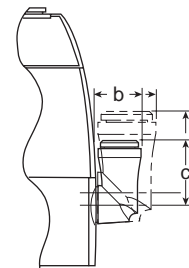

D
 Subbase & Manual Valves
 H Series Micro
 Moduflex Series
 H Series ISO
 Fieldbus Systems
 DX ISOMAX Series
 Valvair II Series



For inventory, lead times, and kit lookup, visit www.pdnplu.com

"V" Series Manifold Dimensions and Mounting
 20-pin, Multi-Connector Valve Manifold



Total Width Depends
 on Valve Composition

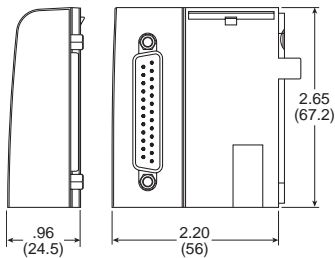
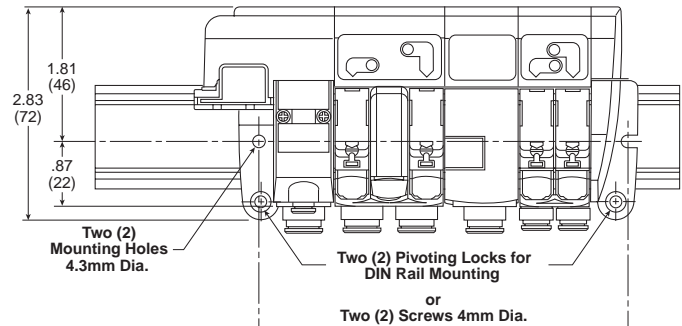
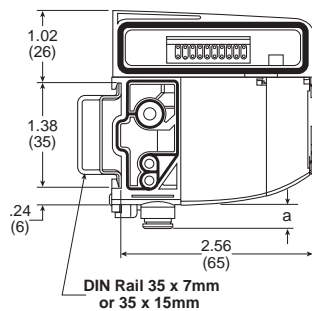

25-pin,
 D-Sub

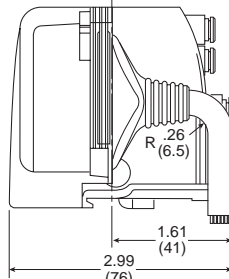

20-pin,
 Multi-Connector

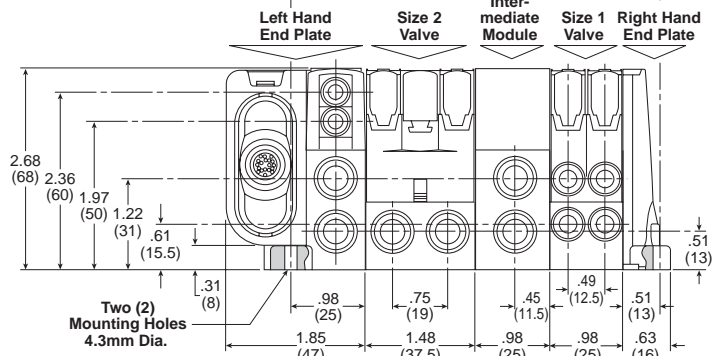

End Plate and Intermediate Modules

	a	b	c
6 mm Tube OD	8	13	16
1/4" Tube OD	12	18	22
8 mm Tube OD	9	16	19
3/8" Tube OD	16	23	26
10 mm Tube OD	13	18	25
12 mm Tube OD	13	19	25
1/2" Tube OD	13		
Muffler	40		

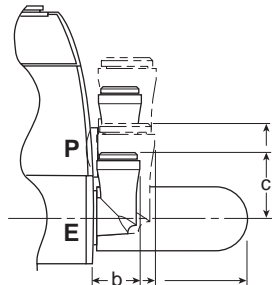

OD Tube	Ext.	a	b	c
Size 1 Modules	5/32" (4 mm)	8	10	12
	6 mm	8	13	16
	1/4"	15	18	22
Size 2 Modules	1/4"	12	18	22
	8 mm	9	16	19
	3/8"	16	23	26
	10 mm	13	18	22

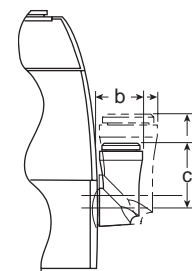

For inventory, lead time, and kit lookup, visit www.pdnplu.com

D69

Parker Hannifin Corporation
 Pneumatic Division
 Richland, Michigan
www.parker.com/pneumatics

D

Subbase & Manual Valves

H Series Micro

Moduflex Series

H Series ISO

Fieldbus Systems

DX ISOMAX Series

Valvair II Series

"V" Series Manifold Dimensions and Mounting
 Fieldbus Connected Manifolds

Total Width Depends
 on Valve Composition

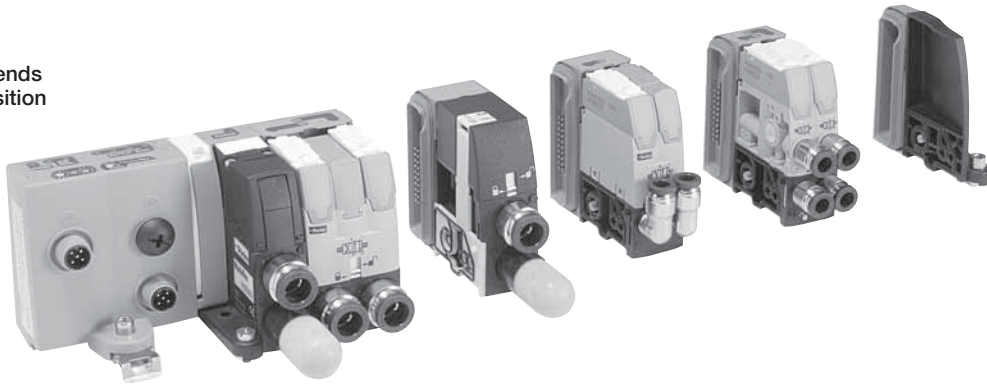

AS-i Bus Islands

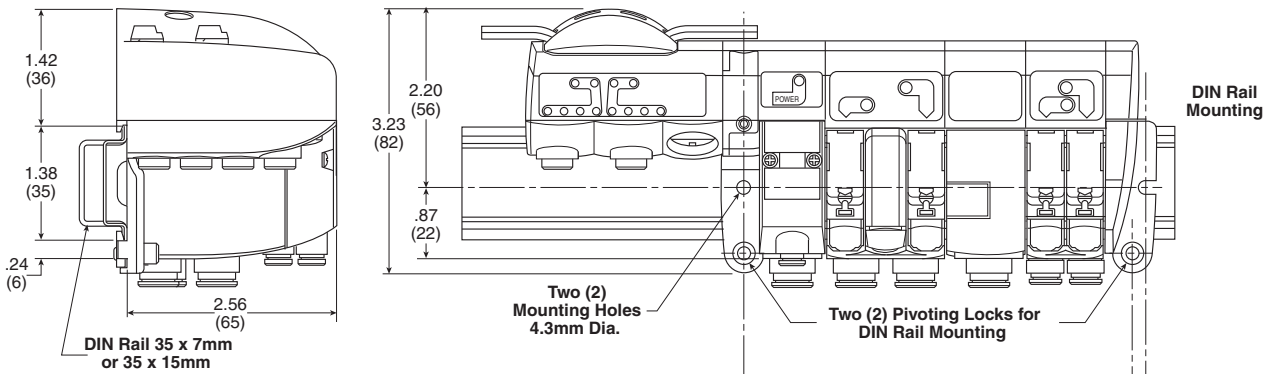

Device Bus and IO-Link Valve Islands

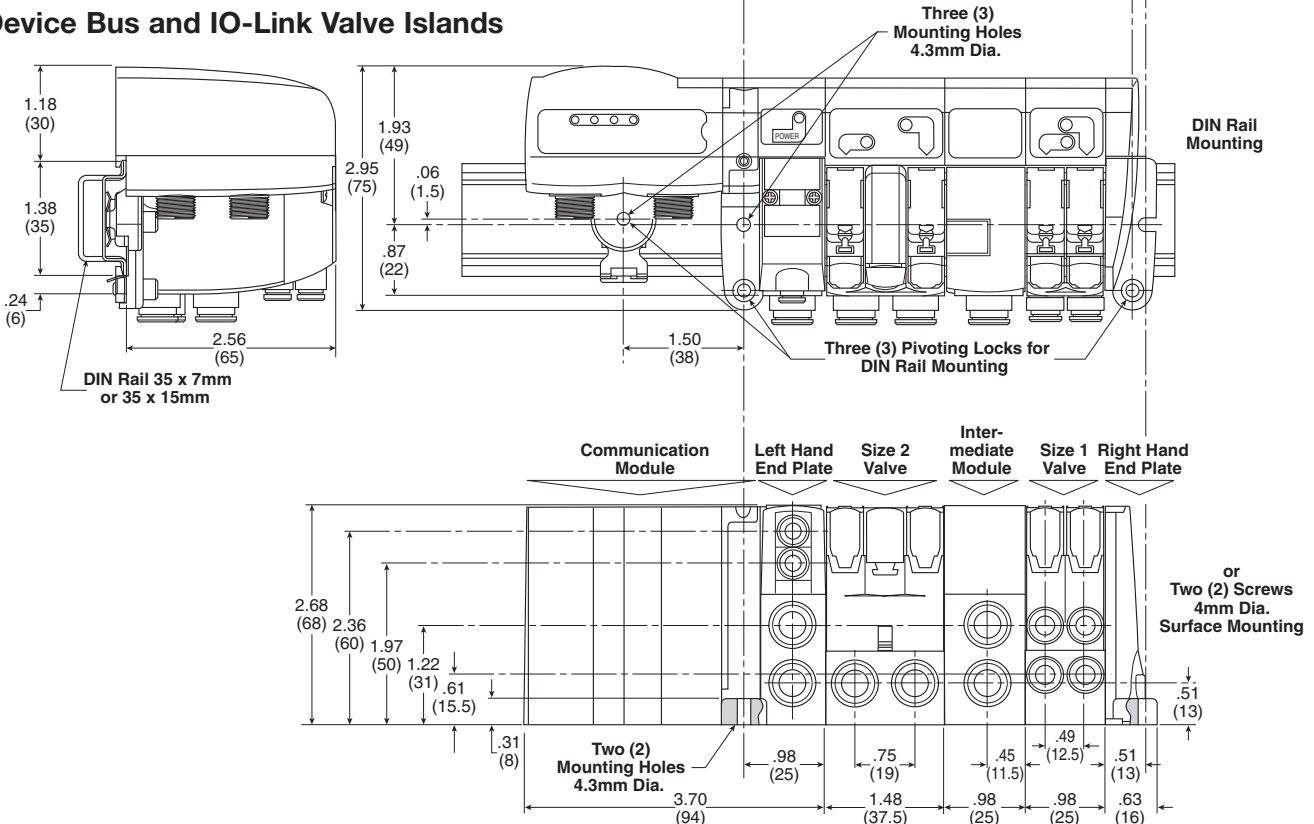

D	Subbase & Manual Valves
H Series Micro	Moduflex Series
H Series ISO	Fieldbus Systems
DX ISOMAX Series	Valvair II Series



For inventory, lead times, and kit lookup, visit www.pdnplu.com

D70

Parker Hannifin Corporation
 Pneumatic Division
 Richland, Michigan
www.parker.com/pneumatics

"P" Series Peripheral Modules Dimensions and Mounting

Reminder: Peripheral modules may either be plugged in the valve output ports or mounted in-line separate from the valve.

Peripheral Module
 Plugged in a Valve

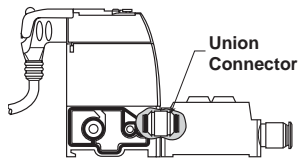

In-Line Peripheral Modules:
 Mounting is Required

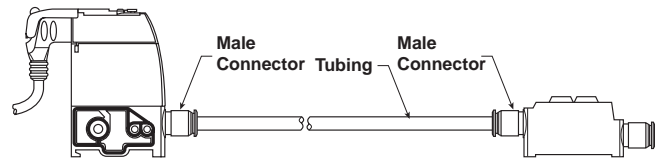

Dual Flow Control Size 1

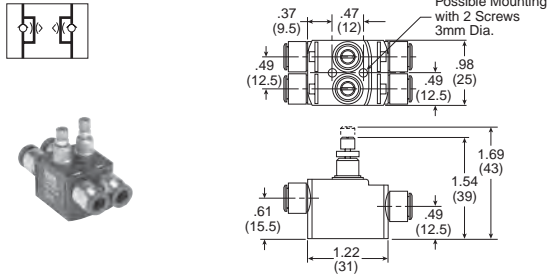

Dual Flow Control Size 2

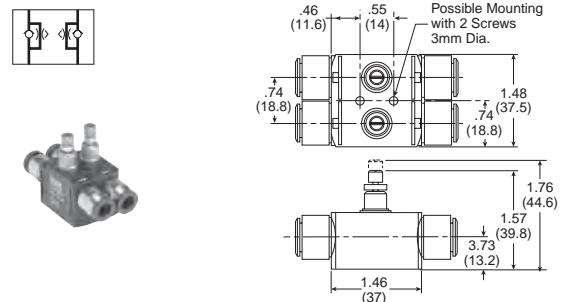

Pressure Regulator Size 1

With Gauge

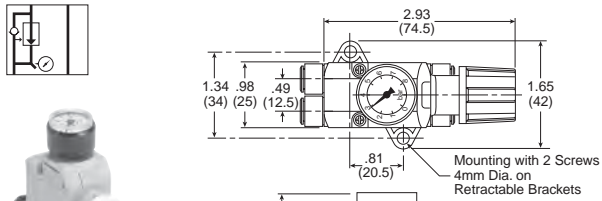

Pressure Regulator Size 2

With Gauge

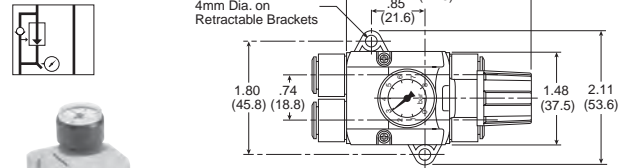

Without Gauge

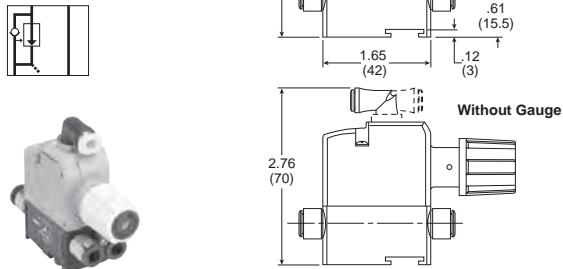

Without Gauge

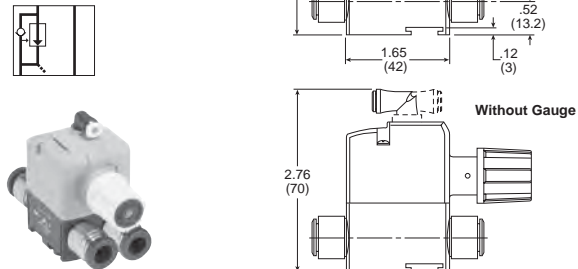

Dual P.O. Check Valve Size 1

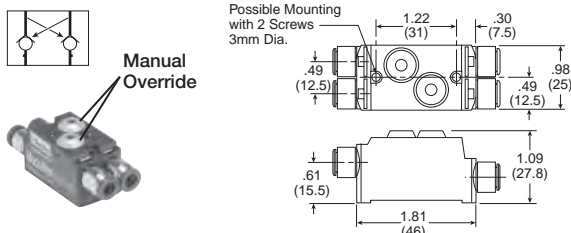

Dual P.O. Check Valve Size 2

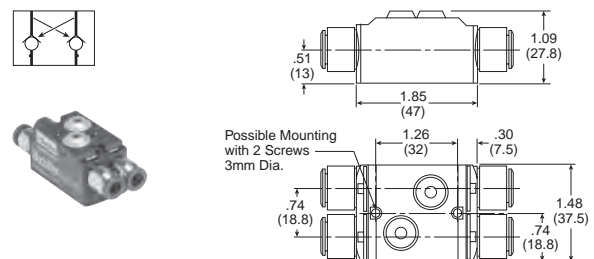

For inventory, lead time, and kit lookup, visit www.pdnplu.com

H Series ISO

The H Series ISO valve conforms to international standards 15407 and 5599, providing maximum flexibility for end users. As Parker's premier manifold mount product offering, H Series ISO offers machine builders a complete offering with a wide variety of accessories and options in a valve family with flow ranges from 0.55 Cv up to 6.0 Cv. Individual wiring is available with DIN or central connectors, and collective solutions offer installation time savings with either multi-pin connectors or fieldbus solutions.

Ports, Flow

- HB: 1/8 inch, 0.55 Cv
- HA: 1/4 inch, 1.1 Cv
- H1: 3/8 inch, 1.5 Cv
- H2: 1/2 inch, 3.0 Cv
- H3: 3/4 inch, 6.0 Cv
- NPT and BSPP "G" standard

Mounting

- Manifold or subbase

Solenoids

- HB & HA: 24 VDC, 1.0 Watt, and 120 VAC, 1.0 VA
- H1, H2, & H3: 24 VDC, 3.2 Watt, and 120 VAC, 4.5 VA

Certification / approval

- IP65 rated
- CSA / C-US approved
- BSPP manifold and subbase ports meet ISO 1179 specifications

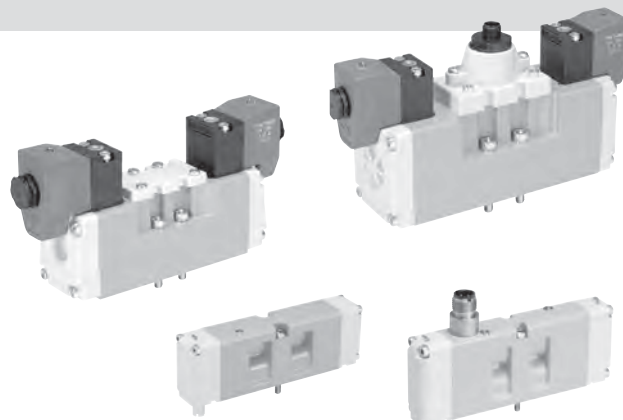

Operating information

Operating pressure:	Vacuum to 145 PSIG (Vacuum to 10 bar)
Pilot pressure:	See chart
Temperature range:	5°F to 120°F (-15°C to 49°C)

Material specifications

Body	Aluminum
End caps	PBT
End plates	Aluminum
Fasteners	Zinc plated steel
Manifolds	Aluminum
Seals	Nitrile
Spool	Aluminum

Operating Pressure

Maximum: 145 PSIG (1000 kPa)

Minimum:

Operator / function	Internal pilot	PSIG (Min. kPa) HB	PSIG (Min. kPa) HA	PSIG (Min. kPa) H1	PSIG (Min. kPa) H2	PSIG (Min. kPa) H3
1	Single solenoid - 2-position	30	25	25	25	35
2	Double solenoid - 2-position	(207)	(173)	(173)	(173)	(241)
3	Single remote pilot - 2-position**	Vacuum	Vacuum	Vacuum	Vacuum	Vacuum
4	Double remote pilot - 2-position**	Vacuum	Vacuum	Vacuum	Vacuum	Vacuum
5, 6, 7	Double solenoid - 3-position APB, CE, PC	35 (241)	35 (241)	35 (241)	50 (345)	50 (345)
8, 9, 0	Double remote pilot - 3-position** APB, CE, PC	Vacuum	Vacuum	Vacuum	Vacuum	Vacuum
E	Single solenoid pilot - 2-position					
	Air return / spring assist	30	30	35	45	45
		(207)	(207)	(241)	(310)	(310)
F	Single remote pilot - 2-position**					
	Air return / spring assist					
N, P, Q	Double solenoid - dual 3/2	30 (207)	N/A	N/A	N/A	N/A
	External pilot*	*	*	*	*	*
All	H Series	Vacuum	Vacuum	Vacuum	Vacuum	Vacuum

* External Pilot Pressure / Remote Pilot Supply - Must meet or exceed minimum pilot pressure for internal pilot option. Not available on Operator / Function N, P, or Q.

** Must be equal to or greater than operating pressure.

D

Subbase & Manual Valves

H Series Micro

Modulflex Series

H Series ISO

Fieldbus Systems

DX ISOMAX Series

Valvair II Series



For inventory, lead times, and kit lookup, visit www.pdnplu.com

ISO Pneumatic Valve Standard Definitions

15407-1: Non-Plug-in Standards for Size 01 (26mm) & Size 02 (18mm) Wide Valves

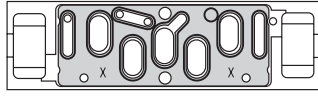

15407-2: Plug-in Standards for Size 01 (26mm) & Size 02 (18mm) Wide Valves

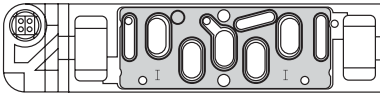

5599-1: Non-Plug-in Standards for Sizes 1, 2, 3

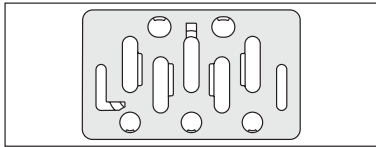

5599-2: Plug-in Standards for Size 1, 2, 3

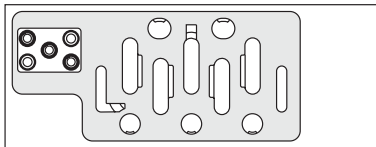

HB / HA Series

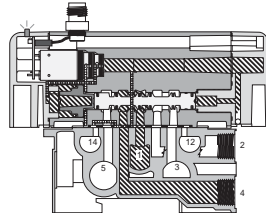

15407-1 18mm Single Solenoid Internal Pilot Manifold Mounted

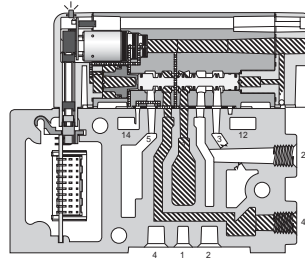

15407-2 18mm Single Solenoid Internal Pilot Manifold Mounted

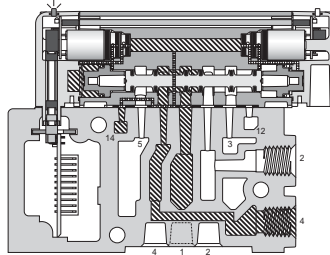

15407-2 26mm Double Solenoid External Pilot Manifold Mounted

▨ Pressure □ Exhaust

H1, H2, H3 Series

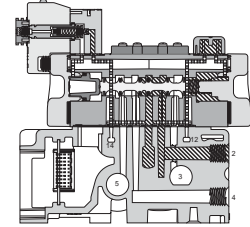

H1 5599-2 Single Solenoid Internal Pilot Manifold Mounted

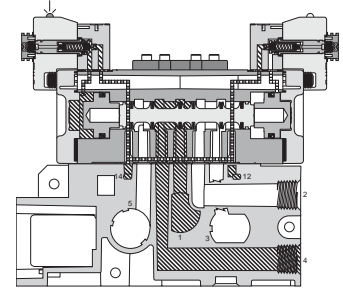

H2 5599-2 Double Solenoid External Pilot Manifold Mounted

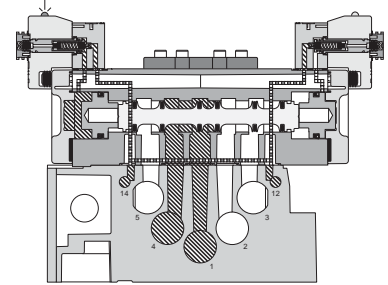

H3 5599-2 Double Solenoid External Pilot Subbase Mounted

▨ Pressure □ Exhaust





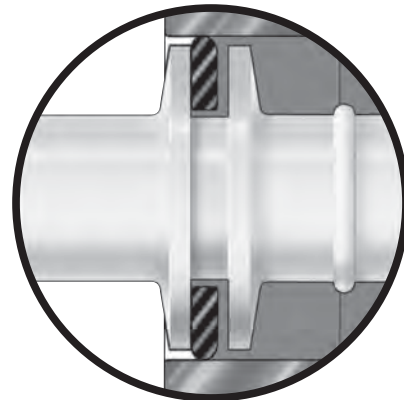



Wear Compensation System









- Maximum Performance
 - Low Friction
 - Lower Operating Pressures
 - Fast Response
 - Less Wear
- Long Cycle Life - Under pressure, radial expansion of the seal occurs to maintain sealing contact with the valve bore.
- Non-Lube Service - No lubrication required for continuous valve shifting.
- Bi-Directional Spool Seals - Common spool used for any pressure, including vacuum.





For inventory, lead time, and kit lookup, visit www.pdnplu.com

15407-2, Plug-in, Size 18mm (HB)

Symbol	Type	Cv	Operator	Voltage	Pilot	Non-locking	Locking
 Sol. 14	4-way, 2-position, spring return	0.55	Single solenoid	24 VDC	Internal	HBEVXBG0G9A	HBEVXBH0G9A
					External	HBEVXLG0G9A	HBEVXLH0G9A
 Sol. 14	4-way, 2-position, air return	0.55	Single solenoid	24 VDC	Internal	HB1VXBG0G9A	HB1VXBH0G9A
					External	HB1VXLG0G9A	HB1VXLH0G9A
 Sol. 14 Sol. 12	4-way, 2-position	0.55	Double solenoid	24 VDC	Internal	HB2VXBG0G9A	HB2VXBH0G9A
					External	HB2VXLG0G9A	HB2VXLH0G9A
 #14	4-way, 3-position, all ports blocked	0.5	Double solenoid	24 VDC	Internal	HB5VXBG0G9A	HB5VXBH0G9A
					External	HB5VXLG0G9A	HB5VXLH0G9A
 #14	4-way, 3-position, center exhaust	0.5	Double solenoid	24 VDC	Internal	HB6VXBG0G9A	HB6VXBH0G9A
					External	HB6VXLG0G9A	HB6VXLH0G9A
 #14	4-way, 3-position, pressure center	0.5	Double solenoid	24 VDC	Internal	HB7VXBG0G9A	HB7VXBH0G9A
					External	HB7VXLG0G9A	HB7VXLH0G9A
 #14	3-way, 2-position, dual valve, NC/NC	0.45	Double solenoid	24 VDC	Internal	HBNVXBG0G9A	HBNVXBH0G9A
					Internal	HBPVXBG0G9A	HBPVXBH0G9A
 #14	3-way, 2-position, dual valve, NO/NO	0.45	Double solenoid	24 VDC	Internal	HBNVXBG0G9A	HBNVXBH0G9A
					Internal	HBPVXBG0G9A	HBPVXBH0G9A

Symbol	Type	Cv	Operator	Voltage	Pilot	Non-locking	Locking
 Sol. 14	4-way, 2-position, spring return	0.55	Single solenoid	120 VAC	Internal	HBEVXBG023A	HBEVXBH023A
					External	HBEVXLG023A	HBEVXLH023A
 Sol. 14	4-way, 2-position, air return	0.55	Single solenoid	120 VAC	Internal	HB1VXBG023A	HB1VXBH023A
					External	HB1VXLG023A	HB1VXLH023A
 Sol. 14 Sol. 12	4-way, 2-position	0.55	Double solenoid	120 VAC	Internal	HB2VXBG023A	HB2VXBH023A
					External	HB2VXLG023A	HB2VXLH023A
 #14	4-way, 3-position, all ports blocked	0.5	Double solenoid	120 VAC	Internal	HB5VXBG023A	HB5VXBH023A
					External	HB5VXLG023A	HB5VXLH023A
 #14	4-way, 3-position, center exhaust	0.5	Double solenoid	120 VAC	Internal	HB6VXBG023A	HB6VXBH023A
					External	HB6VXLG023A	HB6VXLH023A
 #14	4-way, 3-position, pressure center	0.5	Double solenoid	120 VAC	Internal	HB7VXBG023A	HB7VXBH023A
					External	HB7VXLG023A	HB7VXLH023A
 #14	3-way, 2-position, dual valve, NC/NC	0.45	Double solenoid	120 VAC	Internal	HBNVXBG023A	HBNVXBH023A
					Internal	HBPVXBG023A	HBPVXBH023A
 #14	3-way, 2-position, dual valve, NO/NO	0.45	Double solenoid	120 VAC	Internal	HBNVXBG023A	HBNVXBH023A
					Internal	HBPVXBG023A	HBPVXBH023A

15407-2, Plug-in, Size 18mm (HB), 2-Station Manifold Bases

End ported bases	Enclosure / Lead length	Solenoid addresses	1/8" NPT	1/8" BSPP
	Circuit board	Single solenoid - 1 address	PS561151JP	PS561152JP
	Circuit board	Double solenoid - 2 addresses	PS561151MP	PS561152MP
	Circuit board with 32 output expansion	Single solenoid - 1 address	PS561151NP	PS561152NP
	Circuit board with 32 output expansion	Double solenoid - 2 addresses	PS561151PP	PS561152PP
Bottom / end ported bases				
	Circuit board	Single solenoid - 1 address	PS561161JP	PS561162JP
	Circuit board	Double solenoid - 2 addresses	PS561161MP	PS561162MP
	Circuit board with 32 output expansion	Single solenoid - 1 address	PS561161NP	PS561162NP
	Circuit board with 32 output expansion	Double solenoid - 2 addresses	PS561161PP	PS561162PP







 Most popular.



For inventory, lead times, and kit lookup, visit www.pdnplu.com

D
 Subbase & Manual Valves
 H Series Micro
 Modutef Series
 H Series ISO
 Fieldbus Systems
 DX ISOMAX Series
 Valvair II Series

15407-2, Plug-in, Size 18mm (HB) Accessories

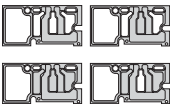
Accessories	Description	Part number
 Sandwich regulator	Common pressure 2-60 PSIG w/ gauge	PS5638155P
	Common pressure 5-125 PSIG w/ gauge	PS5638166P
	Independent pressure 2-60 PSIG w/ gauge	PS5638255P
	Independent pressure 5-125 PSIG w/ gauge	PS5638266P
 Gauge adapter kit	Includes 1/8" coupling and long nipple	PS5651160P
 Blanking plate kit		PS5634P
 Sandwich supply module	1/8" NPT	PS561600P
	1/8" BSPP	PS561601P
 Sandwich exhaust module	1/8" NPT	PS561700P
	1/8" BSPP	PS561701P
 Intermediate air supply module	1/8" NPT	D02P-01-80
 Sandwich flow control		PS5635P
 Manifold to manifold gasket kits	Standard	PS561AP
	Blocked #1 port	PS561BP
	Blocked #1, 3, 5, ports	PS561CP
	Blocked #3, 5 ports	PS561DP

 Most popular.



For inventory, lead time, and kit lookup, visit www.pdnplu.com

D75

Parker Hannifin Corporation
 Pneumatic Division
 Richland, Michigan
www.parker.com/pneumatics

D

Subbase & Manual Valves

H Series Micro

Moduflex Series







H Series ISO







Fieldbus Systems

DX ISOMAX Series

Valvair II Series

15407-2, Plug-in, Size 26mm (HA)



Symbol	Type	Cv	Operator	Voltage	Pilot	Non-locking	Locking
 Sol. 14	4-way, 2-position, spring return	1.1	Single solenoid	24 VDC	Internal	HAEVXBG0G9A	HAEVXBH0G9A
					External	HAEVXLG0G9A	HAEVXLH0G9A
 Sol. 13	4-way, 2-position, air return	1.1	Single solenoid	24 VDC	Internal	HA1VXBG0G9A	HA1VXBH0G9A
					External	HA1VXLG0G9A	HA1VXLH0G9A
 Sol. 14	4-way, 2-position	1.1	Double solenoid	24 VDC	Internal	HA2VXBG0G9A	HA2VXBH0G9A
					External	HA2VXLG0G9A	HA2VXLH0G9A
 APB	4-way, 3-position, all ports blocked	1.0	Double solenoid	24 VDC	Internal	HA5VXBG0G9A	HA5VXBH0G9A
					External	HA5VXLG0G9A	HA5VXLH0G9A
 CE	4-way, 3-position, center exhaust	1.0	Double solenoid	24 VDC	Internal	HA6VXBG0G9A	HA6VXBH0G9A
					External	HA6VXLG0G9A	HA6VXLH0G9A
 PC	4-way, 3-position, pressure center	1.0	Double solenoid	24 VDC	Internal	HA7VXBG0G9A	HA7VXBH0G9A
					External	HA7VXLG0G9A	HA7VXLH0G9A

Symbol	Type	Cv	Operator	Voltage	Pilot	Non-locking	Locking
 Sol. 14	4-way, 2-position, spring return	1.1	Single solenoid	120 VAC	Internal	HAEVXBG023A	HAEVXBH023A
					External	HAEVXLG023A	HAEVXLH023A
 Sol. 13	4-way, 2-position, air return	1.1	Single solenoid	120 VAC	Internal	HA1VXBG023A	HA1VXBH023A
					External	HA1VXLG023A	HA1VXLH023A
 Sol. 14	4-way, 2-position	1.1	Double solenoid	120 VAC	Internal	HA2VXBG023A	HA2VXBH023A
					External	HA2VXLG023A	HA2VXLH023A
 APB	4-way, 3-position, all ports blocked	1.0	Double solenoid	120 VAC	Internal	HA5VXBG023A	HA5VXBH023A
					External	HA5VXLG023A	HA5VXLH023A
 CE	4-way, 3-position, center exhaust	1.0	Double solenoid	120 VAC	Internal	HA6VXBG023A	HA6VXBH023A
					External	HA6VXLG023A	HA6VXLH023A
 PC	4-way, 3-position, pressure center	1.0	Double solenoid	120 VAC	Internal	HA7VXBG023A	HA7VXBH023A
					External	HA7VXLG023A	HA7VXLH023A

15407-2, Plug-in, Size 26mm (HA), Single Subbase

Enclosure / Lead length	Solenoid addresses	1/4" NPT	1/4" BSPP
 Terminal strip in the base	Double solenoid - 2 addresses	PS55113CP	PS55114CP

15407-2, Plug-in, Size 26mm (HA), 2-Station Manifold Bases

End ported bases	Enclosure / Lead length	Solenoid addresses	1/4" NPT	1/4" BSPP
	Circuit board	Single solenoid - 1 address	PS551153JP	PS551154JP
	Circuit board	Double solenoid - 2 addresses	PS551153MP	PS551154MP
	Circuit board with 32 output expansion	Single solenoid - 1 address	PS551153NP	PS551154NP
	Circuit board with 32 output expansion	Double solenoid - 2 addresses	PS551153PP	PS551154PP
	Terminal strip in the base	Double solenoid - 2 addresses	PS551153CP	PS551154CP
Bottom / end ported bases				
	Circuit board	Single solenoid - 1 address	PS551163JP	PS551164JP
	Circuit board	Double solenoid - 2 addresses	PS551163MP	PS551164MP
	Circuit board with 32 output expansion	Single solenoid - 1 address	PS551163NP	PS551164NP
	Circuit board with 32 output expansion	Double solenoid - 2 addresses	PS551163PP	PS551164PP
	Terminal strip in the base	Double solenoid - 2 addresses	PS551163CP	PS551164CP







 Most popular.



For inventory, lead times, and kit lookup, visit www.pdnplu.com

D
 Subbase & Manual Valves
 H Series Micro
 Moduteflex Series
 H Series ISO
 Fieldbus Systems
 DX ISOMAX Series
 Valvair II Series

15407-2, Plug-in, Size 26mm (HA) Accessories

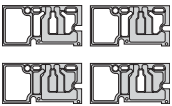





Accessories	Description	Part number
 Sandwich regulator	Common pressure 2-60 PSIG w/ gauge	PS5538155P
	Common pressure 5-125 PSIG w/ gauge	PS5538166P
	Independent pressure 2-60 PSIG w/ gauge	PS5538255P
	Independent pressure 5-125 PSIG w/ gauge	PS5538266P
 Gauge adapter kit	Includes 1/8" coupling and long nipple	PS5651160P
 Blanking plate kit		PS5534P
 Sandwich supply module	1/4" NPT	PS551600P
	1/4" BSPP	PS551601P
 Sandwich exhaust module	1/4" NPT	PS551700P
	1/4" BSPP	PS551701P
 Intermediate air supply module	1/4" NPT	D01P-02-80
 Sandwich flow control		PS5535P
 Manifold to manifold gasket kits	Standard	PS561AP
	Blocked #1 port	PS561BP
	Blocked #1, 3, 5, ports	PS561CP
	Blocked #3, 5 ports	PS561DP

D
 Subbase & Manual Valves
 H Series Micro
 Moduflex Series
 H Series ISO
 Fieldbus Systems
 DX ISOMAX Series
 Valvair II Series

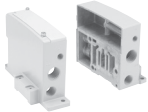

For inventory, lead time, and kit lookup, visit www.pdnplu.com

15407-2, Plug-in, Size 18mm & 26mm End Plate Kits

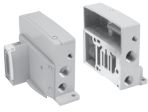
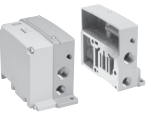
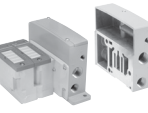
	Electrical option	NPT port	BSPP port
	No connector - HB non plug-in valves HA non plug-in valves, or HA plug-in valves with terminals in base	PS5631010P	PS5631011P
	25-pin, D-Sub	PS5620L20P	PS5620L21P
	19-pin, round, Brad Harrison	PS5620L30P	PS5620L31P
	12-pin, M23	PS5620L40P	PS5620L41P
	16-point terminal strip	PS5620L50P	PS5620L51P
	19-pin, M23	PS5620M20P	PS5620M21P
	Moduflex fieldbus	PS5620M40P	PS5620M41P
	H Series Fieldbus, with valve driver module	PS5620L60P	PS5620L61P
	Turck fieldbus with valve driver module - 16 outputs	PS5620T10P	PS5620T11P
	Turck fieldbus with valve driver module - 32 outputs	PS5620T20P	PS5620T21P

15407-2 End Plate Kits with Transition to H2

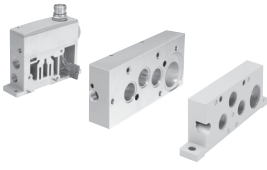
	Electrical option	NPT port	BSPP port
	25-pin, D-sub	PS5624L20P	PS5624L21P
	19-pin, round, Brad Harrison	PS5624L30P	PS5624L31P
	12-pin, M23	PS5624L40P	PS5624L41P
	16-point terminal strip	PS5624L50P	PS5624L51P
	19-pin, M23	PS5624M20P	PS5624M21P
	Moduflex fieldbus	PS5624M40P	PS5624M41P
	H Series Fieldbus, with valve driver module	PS5624L60P	PS5624L61P
	Turck fieldbus with valve driver module - 16 outputs	PS5624T10P	PS5624T11P
	Turck fieldbus with valve driver module - 32 outputs	PS5624T20P	PS5624T21P

Turck, H Series Fieldbus, and Moduflex communication modules must be ordered separately. See Fieldbus Section for more information.

Note:

For cable part numbers and pin out information see Fieldbus System Accessories.

 Most popular.

D
 Subbase & Manual Valves
 H Series Micro
 Moduflex Series
 H Series ISO
 Fieldbus Systems
 DX ISOMAX Series
 Valvair II Series



For inventory, lead times, and kit lookup, visit www.pdnplu.com

15407-2, Plug-in, Size 18mm (HB) & 26mm (HA)

HB 1 VX B G 0 G9 A

Basic series 15407-2	
ISO 15407-2 18mm	HB
ISO 15407-2 26mm	HA

15407-2 Engineering level	
A	Current

15407-2 Operator / Function	
Single solenoid, 2-position - air return	1
Double solenoid, 2-position	2
Double solenoid, 3-position - APB	5
Double solenoid, 3-position - CE	6
Double solenoid, 3-position - PC	7
Single solenoid, 2-position - air return, spring assist	E
Double solenoid, dual 3/2, NC/NC	N*
Double solenoid, dual 3/2, NO/NO	P*
Double solenoid, dual 3/2, 14 end NC - 12 end NO	Q*

15407-2 Voltage & frequency				
	AC		DC	Light & surge suppression
	60Hz	50Hz		
G9			24	LED & suppression
23	120	115		LED & suppression

15407-2 Enclosure / Lead length	
0	Valve less base

15407-2 Overrides / Lights	
G	Non-locking, flush, push - w/ light
H	Locking, flush, push / turn - w/ light

* Available on HB Only, must use Internal Pilot Source Option "B".

Mounting	
15407-2 Valve less base	VX

15407-2 Pilot source / Pilot exhaust	
Internal pilot, port #1 / vented	B
External pilot, port #14 / vented	L*

* Must be specified when using Sandwich Regulators.

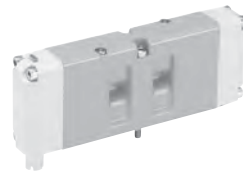

HB: 18mm

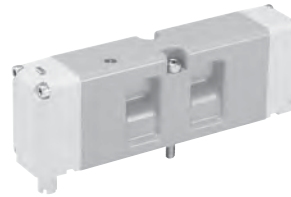

HA: 26mm

Most popular.



For inventory, lead time, and kit lookup, visit www.pdnplu.com

D

Subbase & Manual Valves

H Series Micro

Moduflex Series

H Series ISO

Fieldbus Systems

DX ISOMAX Series

Valvair II Series

15407-2, Plug-in, Size 18mm (HB) & 26mm (HA)

Manifold / Subbase Kits

PS551113

C

P

Mounting Style / Port Size	
ISO 15407-2, 18mm HB	
Manifold with 1/8 NPT End Ports	PS561151
Manifold with 1/8 BSPP End Port	PS561152*
Manifold with 1/8 NPT Bottom / End Port	PS561161
Manifold with 1/8 BSPP Bottom / End Port	PS561162*
ISO 15407-2, 26mm HA	
Subbase with 1/4 NPT Side Ports	PS551113
Subbase with 1/4 BSPP Side Ports	PS551114*
Subbase with 1/4 NPT Bottom / Side Port	PS551123
Subbase with 1/4 BSPP Bottom / Side Port	PS551124*
Manifold with 1/4 NPT End Port	PS551153
Manifold with 1/4 BSPP End Port	PS551154*
Manifold with 1/4 NPT Bottom / End Port	PS551163
Manifold with 1/4 BSPP Bottom / End Port	PS551164*

* BSPP Conforms to ISO 1179-1 w 228-1 Threads.

Enclosures / Lead Length	
Individually Wired Base	
C [†]	Terminal Strip
Collective Wired Base	
J [*]	Circuit Board, Single Address
M [*]	Circuit Board, Double Address
N [§]	Single Address Circuit Board with 32 Output Expansion
P [‡]	Double Address Circuit Board with 32 Output Expansion

* Manifolds Only.

† Available with HA (26mm). Conduit port included on left hand end plate for wires to exit.

§ When using an HA or HB manifold base with the "N" Enclosure / Lead Length option:

- Outputs 1 – 24 can be single or double address bases. Use a base with "J" or "M" Enclosure / Lead Length option.
- Outputs 25 – 26 are a single address base. Use a base with "N" Enclosure / Lead Length option (this is a single address board with a ribbon connection from the valve driver module, PSSV32A).
- Outputs 27 – 32 can be single or double. Use a base with "J" or "M" Enclosure / Lead Length option.

‡ When using an HA or HB manifold base with the "P" Enclosure / Lead Length option:

- Outputs 1 – 24 can be single or double address bases. Use a base with "J" or "M" Enclosure / Lead Length option.
- Outputs 25 – 28 are a double address base. Use a base with "P" Enclosure / Lead Length option (this is a double address board with a ribbon connection from the valve driver module, PSSV32A).
- Outputs 29 – 32 can be single or double. Use a base with "J" or "M" Enclosure / Lead Length option.

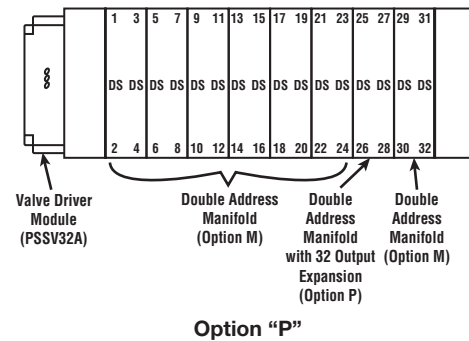
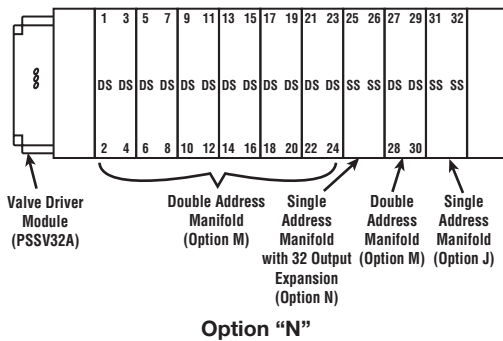

Most popular.



For inventory, lead times, and kit lookup, visit www.pdnplu.com

D80

Parker Hannifin Corporation
 Pneumatic Division
 Richland, Michigan
www.parker.com/pneumatics

D
 Subbase & Manual Valves
 H Series Micro
 Moduteflex Series
 H Series ISO
 Fieldbus Systems
 DX ISOMAX Series
 Valvair II Series

Plug-in, 15407-2, Size 18mm (HB) & 26mm (HA)

End Plate Kits

PS5620L6

0

P

Thread Type	
0	NPT
1*	BSPP "G"

* BSPP Conforms to ISO 1179-1 w 228-1 Threads

End Plate Type	
PS563101 †	No Connector - Use with Individually Wired Base
PS5620L2*	25-Pin, D-Sub
PS5620L3	19-Pin, Round, Brad Harrison
PS5620L4	12-Pin, M23
PS5620L5	16-Point Terminal Strip
PS5620M2	19-Pin, M23
PS5620M4	Moduflex Fieldbus
PS5620L6	H Series Fieldbus, with Valve Driver Module
PS5620T1	Turck Fieldbus with Valve Driver Module - 16 outputs
PS5620T2	Turck Fieldbus with Valve Driver Module - 32 outputs

* 120VAC is not CSA rated.

† HA Series only.

Turck, H Series Fieldbus, and Moduflex communication modules must be ordered separately. See Fieldbus Section for more information.

D
Subbase & Manual Valves
H Series Micro
Moduflex Series
H Series ISO
Fieldbus Systems
DX ISOMAX Series
Valvair II Series



For inventory, lead time, and kit lookup, visit www.pdnplu.com

Plug-in, 15407-2, Sandwich Regulators

PS5638 1 6 6 P

Basic Series	
HB	
15407-2, 18mm, Plug-in	PS5638
HA	
15407-2, 26mm, Plug-in	PS5538

#2 Port Regulator / Gauge*	
5	2-60 PSIG w/Gauge
6	5-125 PSIG w/Gauge

* For Common Pressure Regulator Option, Regulator Gauge callout must be the same number for both Port #4 and Port #2. (Example: 166)

Regulator Function	
Common Pressure Regulator	1
Independent Pressure Regulator	2

#4 Port Regulator / Gauge*	
5	2-60 PSIG w/Gauge
6	5-125 PSIG w/Gauge

* For Common Pressure Regulator Option, Regulator Gauge callout must be the same number for both Port #4 and Port #2. (Example: 166)

Ordering Components

- Sandwich Regulator Kit configured for Internal Pilot as standard.
- Order valve as External Pilot.

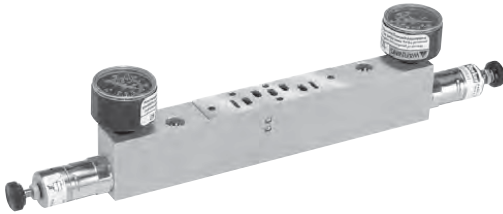

HB - 18mm
 (Independent Dual Port Regulator Shown)



HA - 26mm
 (Common Port Regulator Shown)

How to Configure Sandwich Regulator / Valve Combinations

Internal Pilot Configuration of Sandwich Regulator HA, HB

Pressure in Base Port 1 feeds regulator configured for Internal Pilot which feeds valve configured for External Pilot.

Sandwich Regulator Cv Flow Chart*

	Common Pressure Code 166				Dual Pressure Code 266			
	1-2	1-4	2-3	4-5	1-2	1-4	2-3	4-5*
HB	0.20	0.20	0.41	0.34	0.23	0.19	0.28	0.27
HA	0.41	0.43	0.87	0.89	0.42	0.45	0.68	0.66

* Regulator Port exhaust through Base Port 3.
 Note: All Cv's calculated with regulator adjusted full open.

D
 Subbase & Manual Valves
 H Series Micro
 Modutefx Series
 H Series ISO
 Fieldbus Systems
 DX ISOMAX Series
 Valvair II Series



For inventory, lead times, and kit lookup, visit www.pdnplu.com

Plug-in, HB & HA Common Port Regulation

Provides adjustable regulated air pressure to the valve's #1 port which gives the same pressure to both the #2 and #4 port of the manifold or subbase. The regulator is always on the 14 end of the valve.

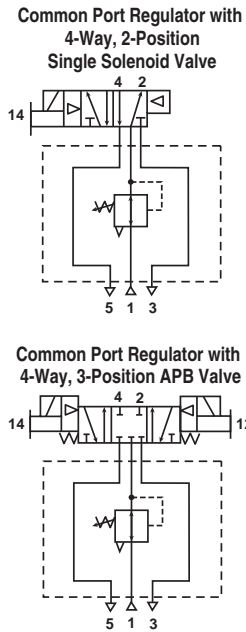

HB Common Port Regulator Shown - Single Solenoid, 14 Energized

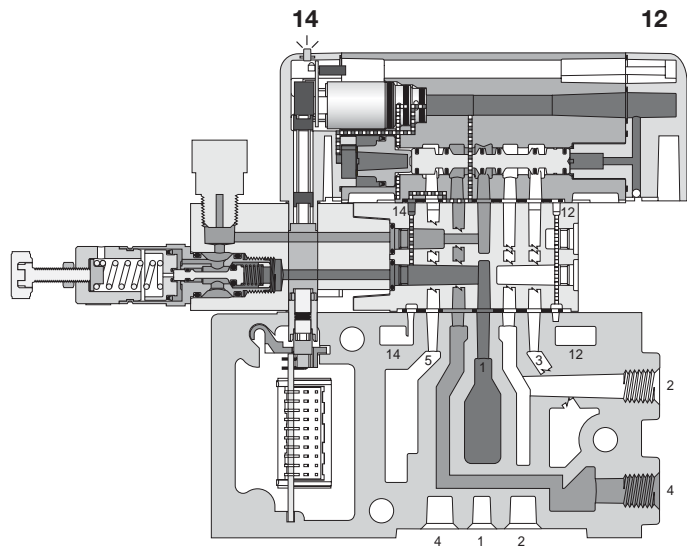

Plug-in, HB & HA Independent Dual Port Regulation

Dual Port Regulator

Provides regulated pressure to both ports. Pressure regulation can occur out of the #2 or #4 port of the valve.

HB Independent Dual Port Regulator Shown - Double Solenoid, 14 Energized

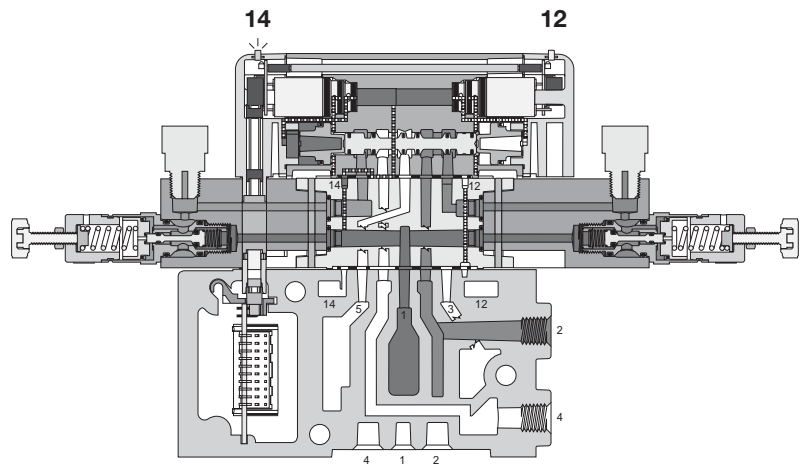
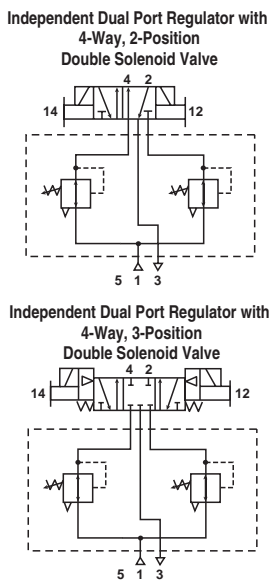

When using an Independent Pressure Sandwich Regulator, the cylinder outlet ports are reversed. The 12 end energizes the #4 port and the 14 end energizes the #2 port. The 3-Position CE and PC functions are also reversed. (See schematics above.)



For inventory, lead time, and kit lookup, visit www.pdnplu.com

D83

Parker Hannifin Corporation
 Pneumatic Division
 Richland, Michigan
www.parker.com/pneumatics

D

Subbase & Manual Valves

H Series Micro

Moduflex Series

H Series ISO

Fieldbus Systems

DX ISOMAX Series

Valvair II Series

Ordering Information

Subbase & Manifold Valve Products H ISO 15407-2, Plug-in, Size 18mm & 26mm

How To Order Plug-in Add-A-Fold Assemblies

1. List Add-A-Fold Assembly call out. This automatically includes the end plate kit assembly.
2. List complete Valve, Regulator, Flow Control and Base model number. List left to right, LOOKING AT THE CYLINDER PORTS on the #12 end of the manifold. The left most station is station 1. (If a blank station is needed, list the blanking plate part number and the individual manifold number in the station specified.)

Example

Application requires a 4-Station manifold.
(Two 18mm + Two 26mm Stations)

Item	Qty.	Part No.	Location
01	1	AAHBD004	
02	1	HB1VXBGOG9A	Station 1
03	1	HB2VXLGOG9A	Station 2
04	1	PS561151MP	Station 1 & 2
05	2	HA1VXBGOG9A	Station 3 & 4
06	1	PS551151MP	Station 3 & 4

NOTE: Construct manifold assemblies from left to right while looking at the ports. Valves must be ordered as External Pilot when using Sandwich Regulator.

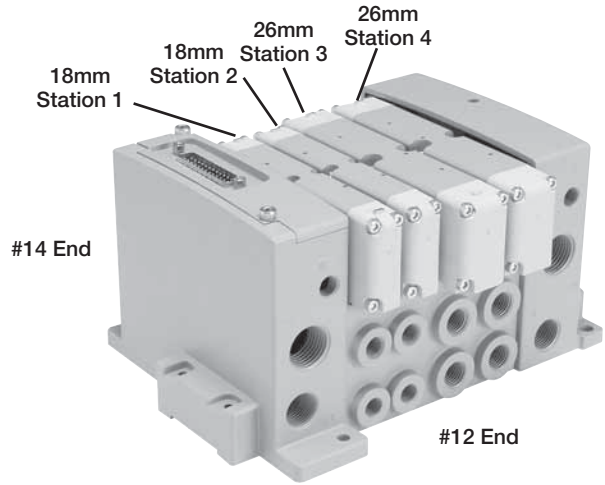

Example:
4-Station Manifold with (2) 18mm and (2) 26mm Valves on Manifold Bases with 25-pin, D-Sub End Plates

Maximum Number of Solenoids (Maximum energized simultaneously)

Voltage	Voltage code	19-pin M23 or		Turck				
		25-pin D-sub	Brad Harrison	12-pin M23	Moduflex	H Series 16	32	
24VDC	G9	24 (24)	16 (16)	8 (8)	24 (24)	32 (32)	16 (16)	32 (32)
120VAC*	23	24 (24)	16 (16)	8 (8)	N/A	N/A	N/A	N/A

* Not CSA certified for 25-pin, D-Sub option.

When using an HA or HB manifold base with the "N" Enclosure / Lead Length option:

- Outputs 1 – 24 can be single or double address bases. Use a base with "J" or "M" Enclosure / Lead Length option.
- Outputs 25 – 26 are a single address base. Use a base with "N" Enclosure / Lead Length option (this is a single address board with a ribbon connection from the valve driver module, PSSV32A).
- Outputs 27 – 32 can be single or double. Use a base with "J" or "M" Enclosure / Lead Length option.

When using an HA or HB manifold base with the "P" Enclosure / Lead Length option:

- Outputs 1 – 24 can be single or double address bases. Use a base with "J" or "M" Enclosure / Lead Length option.
- Outputs 25 – 28 are a double address base. Use a base with "P" Enclosure / Lead Length option (this is a double address board with a ribbon connection from the valve driver module, PSSV32A).
- Outputs 29 – 32 can be single or double. Use a base with "J" or "M" Enclosure / Lead Length option.

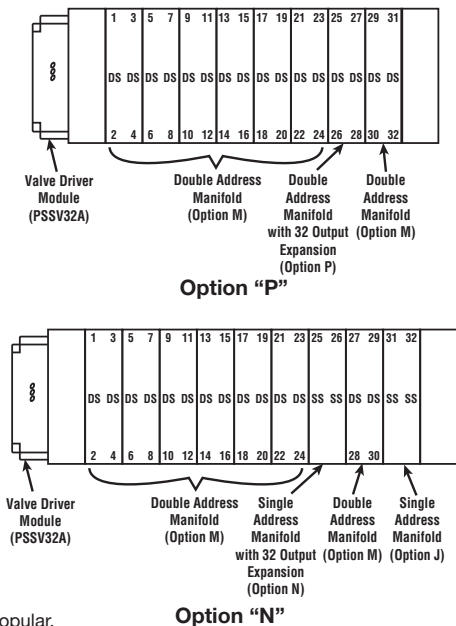

Most popular.

Add-A-Fold Assembly Model Number

AA	HB	D	0	04	
Valve series	Transition Plate				
Right & left end plate 15407-2 (plug-in, HB 18mm & HA 26mm)	Blank No transition plate B HB / HA to H2				
End plate type		Number of stations*			
Turck fieldbus with valve driver module - 16 outputs		02			
Turck fieldbus with valve driver module - 32 outputs		04			
25-pin, D-sub		•			
19-pin, Brad Harrison		24			
16 Point terminal strip		•			
12-pin, M23		32			
19-pin, M23					
Moduflex fieldbus					
H Series Fieldbus, with valve driver module					
Thread type					
0 NPT					
1* BSPP "G"					



* Common end plates for HA & HB.
* Must be ordered in multiples of (2) unless using the HB / HA to H2 Transition Plate.
* Must order communication modules separately.
* BSPP conforms to ISO 1179-1 with 228-1 threads.



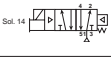

For inventory, lead times, and kit lookup, visit www.pdnplu.com

D
 Subbase & Manual
 Valves
 H Series
 Micro
 Moduflex
 Series
 H Series
 ISO
 Fieldbus
 Systems
 DX ISO MAX
 Series
 Valvar II
 Series

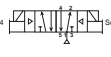
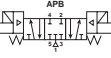
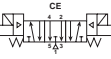
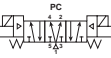
5599-2, Plug-in, Size 1 (H1)

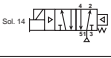
Symbol	Type	Cv	Operator	Voltage	Pilot	Non-locking	Locking
 Sol. 14	4-way, 2-position, spring return	1.5	Single solenoid	24 VDC	Internal	H1EVXBG0B9D	H1EVXBH0B9D
					External	H1EVXXG0B9D	H1EVXXH0B9D
 Sol. 14	4-way, 2-position, air return	1.5	Single solenoid	24 VDC	Internal	H11VXBG0B9D	H11VXBH0B9D
					External	H11VXXG0B9D	H11VXXH0B9D
 Sol. 14 Sol. 12	4-way, 2-position	1.5	Double solenoid	24 VDC	Internal	H12VXBG0B9D	H12VXBH0B9D
					External	H12VXXG0B9D	H12VXXH0B9D
 #14	4-way, 3-position, all ports blocked	1.2	Double solenoid	24 VDC	Internal	H15VXBG0B9D	H15VXBH0B9D
					External	H15VXXG0B9D	H15VXXH0B9D
 #14	4-way, 3-position, center exhaust	1.2	Double solenoid	24 VDC	Internal	H16VXBG0B9D	H16VXBH0B9D
					External	H16VXXG0B9D	H16VXXH0B9D
 #14	4-way, 3-position, pressure center	1.2	Double solenoid	24 VDC	Internal	H17VXBG0B9D	H17VXBH0B9D
					External	H17VXXG0B9D	H17VXXH0B9D

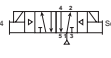
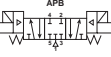
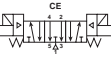
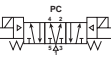
Symbol	Type	Cv	Operator	Voltage	Pilot	Non-locking	Locking
 Sol. 14	4-way, 2-position, spring return	1.5	Single solenoid	120 VAC	Internal	H1EVXBG023D	H1EVXBH023D
					External	H1EVXXG023D	H1EVXXH023D
 Sol. 14	4-way, 2-position, air return	1.5	Single solenoid	120 VAC	Internal	H11VXBG023D	H11VXBH023D
					External	H11VXXG023D	H11VXXH023D
 Sol. 14 Sol. 12	4-way, 2-position	1.5	Double solenoid	120 VAC	Internal	H12VXBG023D	H12VXBH023D
					External	H12VXXG023D	H12VXXH023D
 #14	4-way, 3-position, all ports blocked	1.2	Double solenoid	120 VAC	Internal	H15VXBG023D	H15VXBH023D
					External	H15VXXG023D	H15VXXH023D
 #14	4-way, 3-position, center exhaust	1.2	Double solenoid	120 VAC	Internal	H16VXBG023D	H16VXBH023D
					External	H16VXXG023D	H16VXXH023D
 #14	4-way, 3-position, pressure center	1.2	Double solenoid	120 VAC	Internal	H17VXBG023D	H17VXBH023D
					External	H17VXXG023D	H17VXXH023D

5599-2, Plug-in Single Subbase, Size 1 (H1)

Side ported	Enclosure / Lead length	Solenoid addresses	3/8" NPT	3/8" BSPP
	Terminal strip in base	Double solenoid - 2 address	PS401115CDP	PS401116CDP
	6" flying leads	Double solenoid - 2 addresses	PS401115ADP	PS401116ADP
	4-pin, M12 micro connector in base, SAE / Ford wiring	Double solenoid - 2 addresses	PS4011158FDP	PS4011168FDP

5599-2, Plug-in Manifold Bases, Size 1 (H1)

Bottom / End	Enclosure / Lead length	Solenoid addresses	3/8" NPT	3/8" BSPP
	Circuit board	Single solenoid - 1 address	PS401165JCP	PS401166JCP
	Circuit board	Double solenoid - 2 addresses	PS401165MCP	PS401166MCP
	Terminal strip in base	Double solenoid - 2 address	PS401165CCP	PS401166CCP
	6" flying leads	Double solenoid - 2 addresses	PS401165ACP	PS401166ACP
	4-pin, M12 micro connector in base, SAE / Ford wiring	Double solenoid - 2 addresses	PS4011658FCP	PS4011668FCP

End Ported	Enclosure / Lead length	Solenoid addresses	3/8" NPT	3/8" BSPP
	Circuit board	Single solenoid - 1 address	PS401155JCP	PS401156JCP
	Circuit board	Double solenoid - 2 addresses	PS401155MCP	PS401156MCP
	Terminal strip in base	Double solenoid - 2 address	PS401155CCP	PS401156CCP
	6" flying leads	Double solenoid - 2 addresses	PS401155ACP	PS401156ACP

 Most popular.









For inventory, lead time, and kit lookup, visit www.pdnplu.com

D85





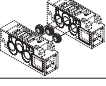

Parker Hannifin Corporation
Pneumatic Division
Richland, Michigan
www.parker.com/pneumatics

D
 Subbase & Manual Valves
 H Series Micro
 Moduflex Series
 H Series ISO
 Fieldbus Systems
 DX ISOMAX Series
 Valvair II Series

5599-2, Size 1 (H1) Accessories

Accessory	Description	Part number
	Common pressure 5-125 PSIG w/ gauge	PS4038166CP
	Independent pressure 5-125 PSIG w/ gauge	PS4038266CP
	Blanking plate kit	PS4034CP
	Sandwich flow control	PS4035CP
	A Sandwich Flow Control and Common Port Sandwich Regulator may be sandwiched together on a manifold or subbase. The Sandwich Flow Control MUST be located between the manifold/subbase and the Common Port Sandwich Regulator.	
	Manifold to manifold gasket kits	PS4013P
	Main galley (1, 3, 5)	PS4032CP
	Pilot galley	PS4033CP
	1/4" & 3/8" NPT	PS403000CP
	BSPP	PS403001CP
Kit includes: Pilot Port Access Plate, Gasket and Mounting Screws. • Used on H1 Manifolds to provide auxiliary access to Ports 1, 3 & 5. • Port 1: 1/4", Ports 3 & 5: 3/8". Height: .72 Inch		

Plug-in, 5599-2 End Plate Kits, Size 1 (H1)

Electrical option	Description	NPT port	BSPP port
	No connector - use with individually wired base	PS4031010DP	PS4031011DP
	25-pin, D-sub	PS4020L20DP	PS4020L21DP
	19-pin, round, Brad Harrison	PS4020L30DP	PS4020L31DP
	12-pin, M23	PS4020L40DP	PS4020L41DP
	19-pin, M23	PS4020M20DP	PS4020M21DP
	Moduflex fieldbus	PS4020M40DP	PS4020M41DP
	H Series Fieldbus, with valve driver module	PS4020L60DP	PS4020L61DP
	Turck fieldbus with valve driver module - 16 outputs	PS4020T10DP	PS4020T11DP
	Turck fieldbus with valve driver module - 24 outputs	PS4020T20DP	PS4020T21DP

Turck, H Series Fieldbus, and Moduflex communication modules must be ordered separately. See Fieldbus Section for more information.

Note:
For cable part numbers and pin out information see Fieldbus System Accessories.

 Most popular.



For inventory, lead times, and kit lookup, visit www.pdnplu.com

D86

Parker Hannifin Corporation
Pneumatic Division
Richland, Michigan
www.parker.com/pneumatics

D
 Subbase & Manual Valves
 H Series Micro
 Moduflex Series
 H Series ISO
 Fieldbus Systems
 DX ISOMAX Series
 Valvair II Series

How To Order Plug-in Add-A-Fold Assemblies

1. List Add-A-Fold Assembly call out. This automatically includes the end plate kit assembly.
2. List complete Valve, Regulator, Flow Control and Base model number. List left to right, LOOKING AT THE CYLINDER PORTS on the #12 end of the manifold. The left most station is station 1. (If a blank station is needed, list the blanking plate part number and the individual manifold number in the station specified.)

Example

Application requires a 3-Station manifold with a valve, regulator on Station 3.

Item	Qty.	Part No.	Location
01	1	AAH1D003	
02	1	H11VXBG0B9D	Station 1
03	1	PS401155MCP	Station 1
04	1	H12VXBG0B9D	Station 2
05	1	PS401155MCP	Station 2
06	1	H12VXXG0B9D	Station 3
07	1	PS4038166CP	Station 3
08	1	PS401155MCP	Station 3

NOTE:

Construct manifold assemblies from left to right while looking at the cylinder ports. Valves must be ordered as External Pilot when using Sandwich Regulator.

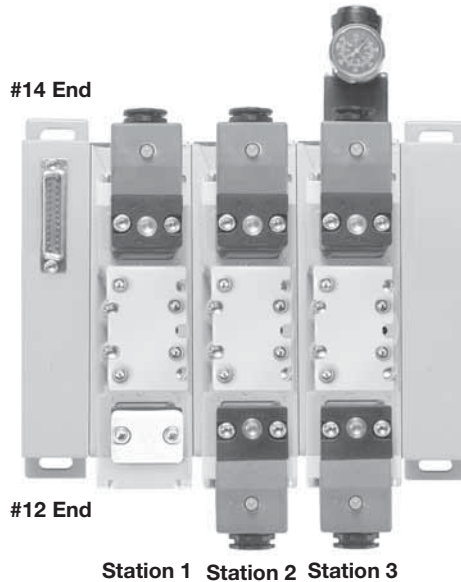

**Example:
 3-Station Manifold with (3) H1 Valves
 on Manifold Bases
 and Regulator at Station 3**

**Maximum Number of Solenoids
 (Maximum energized simultaneously)**

Voltage	Voltage code	25-pin D-sub	19-pin M23 or		12-pin M23	Moduflex	Turck	
			Brad Harrison	Brad Harrison			H Series 16 Fieldbus Outputs	32 Outputs
24VDC	G9	24 (24)	16 (16)	8 (8)	24 (24)†	24 (21)	16 (16)	24 (21)
120VAC*	23	24 (24)	16 (16)	8 (8)	N/A	N/A	N/A	N/A

* Not CSA certified for 25-pin, D-sub option.

† Use Type A IO-Link module for 24 outputs simultaneously.

Add-A-Fold Assembly Model Numbers

AA H1 D 0 03

Valve series	Transition Plate
Right & left end plate H1	Blank No transition plate
	C H1 to H2
	D H1 to H3

End plate type	
Turck fieldbus with valve driver module - 16 outputs	A*
Turck fieldbus with valve driver module - 32 outputs	B*
25-pin, D-sub	D
19-pin, Brad harrison	E
12-pin, M23	G
19-pin, M23	H
Standard, non-collective wiring	S
Moduflex fieldbus	T*
H series fieldbus, with valve driver module	X*

Number of stations
01
02
03
04
•
•
24

Thread type
0 NPT
1* BSPP "G"



* Must order communication modules separately.

Most popular.

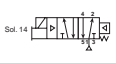
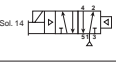
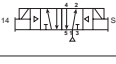
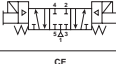
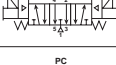

For inventory, lead time, and kit lookup, visit www.pdnplu.com

5599-2, Plug-in, Size 2 (H2)

Symbol	Type	Cv	Operator	Voltage	Pilot	Non-locking	Locking
	4-way, 2-position, spring return	3.0	Single solenoid	24 VDC	Internal	H2EVXBG0B9D	H2EVXBH0B9D
					External	H2EVXXG0B9D	H2EVXXH0B9D
	4-way, 2-position, air return	3.0	Single solenoid	24 VDC	Internal	H21VXBG0B9D	H21VXBH0B9D
					External	H21VXXG0B9D	H21VXXH0B9D
	4-way, 2-position	3.0	Double solenoid	24 VDC	Internal	H22VXBG0B9D	H22VXBH0B9D
					External	H22VXXG0B9D	H22VXXH0B9D
	4-way, 3-position, all ports blocked	2.8	Double solenoid	24 VDC	Internal	H25VXBG0B9D	H25VXBH0B9D
					External	H25VXXG0B9D	H25VXXH0B9D
	4-way, 3-position, center exhaust	2.8	Double solenoid	24 VDC	Internal	H26VXBG0B9D	H26VXBH0B9D
					External	H26VXXG0B9D	H26VXXH0B9D
	4-way, 3-position, pressure center	2.8	Double solenoid	24 VDC	Internal	H27VXBG0B9D	H27VXBH0B9D
					External	H27VXXG0B9D	H27VXXH0B9D

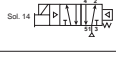
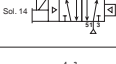
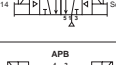
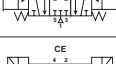
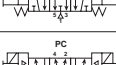
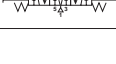
Symbol	Type	Cv	Operator	Voltage	Pilot	Non-locking	Locking
	4-way, 2-position, spring return	3.0	Single solenoid	120 VAC	Internal	H2EVXBG023D	H2EVXBH023D
					External	H2EVXXG023D	H2EVXXH023D
	4-way, 2-position, air return	3.0	Single solenoid	120 VAC	Internal	H21VXBG023D	H21VXBH023D
					External	H21VXXG023D	H21VXXH023D
	4-way, 2-position	3.0	Double solenoid	120 VAC	Internal	H22VXBG023D	H22VXBH023D
					External	H22VXXG023D	H22VXXH023D
	4-way, 3-position, all ports blocked	2.8	Double solenoid	120 VAC	Internal	H25VXBG023D	H25VXBH023D
					External	H25VXXG023D	H25VXXH023D
	4-way, 3-position, center exhaust	2.8	Double solenoid	120 VAC	Internal	H26VXBG023D	H26VXBH023D
					External	H26VXXG023D	H26VXXH023D
	4-way, 3-position, pressure center	2.8	Double solenoid	120 VAC	Internal	H27VXBG023D	H27VXBH023D
					External	H27VXXG023D	H27VXXH023D

5599-2, Plug-in Single Subbase, Size 2 (H2)

Side ported base	Enclosure / Lead length	Solenoid addresses	1/2" NPT	1/2" BSPP
	Terminal strip in base	Double solenoid - 2 address	PS411117CCP	PS411118CCP
	6" flying leads	Double solenoid - 2 addresses	PS411117ACP	PS411118ACP

5599-2, Plug-in Manifold Bases, Size 2 (H2)

Bottom / End ported bases	Enclosure / Lead length	Solenoid addresses	1/2" NPT	1/2" BSPP
	Circuit board	Single solenoid - 1 address	PS411167JCP	PS411168JCP
	Circuit board	Double solenoid - 2 addresses	PS411167MCP	PS411168MCP
	Terminal strip in base	Double solenoid - 2 address	PS411167CCP	PS411168CCP
	6" flying leads	Double solenoid - 2 addresses	PS411167ACP	PS411168ACP
End Ported	Enclosure / Lead length	Solenoid addresses	1/2" NPT	1/2" BSPP
	Circuit board	Single solenoid - 1 address	PS411157JCP	PS411158JCP
	Circuit board	Double solenoid - 2 addresses	PS411157MCP	PS411158MCP
	Terminal strip in base	Double solenoid - 2 address	PS411157CCP	PS411158CCP
	6" flying leads	Double solenoid - 2 addresses	PS411157ACP	PS411158ACP

 Most popular.







For inventory, lead times, and kit lookup, visit www.pdnplu.com

D88





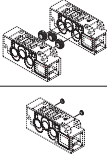

Parker Hannifin Corporation
Pneumatic Division
Richland, Michigan
www.parker.com/pneumatics

D
 Subbase & Manual Valves
 H Series Micro
 Moduteflex Series
 H Series ISO
 Fieldbus Systems
 DX ISOMAX Series
 Valvair II Series

5599-2, Size 2 (H2) Accessories

Accessory	Description	Part number
	Common pressure 5-125 PSIG w/ gauge	PS4138166CP
	Independent pressure 5-125 PSIG w/ gauge	PS4138266CP
	Blanking plate kit	PS4134CP
	Sandwich flow control	PS4135CP
	A Sandwich Flow Control and Common Port Sandwich Regulator may be sandwiched together on a manifold or subbase. The Sandwich Flow Control MUST be located between the manifold/subbase and the Common Port Sandwich Regulator.	
	Manifold to manifold gasket kits	PS4113P
	Main galley (1, 3, 5)	PS4132CP
	Pilot galley	PS4033CP

Plug-in, 5599-2 End Plate Kits, Size 2 (H2)

Electrical option	Description	NPT port	BSPP port
	No connector - use with individually wired base	PS4131010DP	PS4131011DP
	25-pin, D-sub	PS4120L20DP	PS4120L21DP
	19-pin, round, Brad Harrison	PS4120L30DP	PS4120L31DP
	12-pin, M23	PS4120L40DP	PS4120L41DP
	19-pin, M23	PS4120M20DP	PS4120M21DP
	Moduflex fieldbus	PS4120M40DP	PS4120M41DP
	H Series Fieldbus, with valve driver module	PS4120L60DP	PS4120L61DP
	Turck fieldbus with valve driver module - 16 outputs	PS4120T10DP	PS4120T11DP
	Turck fieldbus with valve driver module - 24 outputs	PS4120T20DP	PS4120T21DP

Turck, H Series Fieldbus, and Moduflex communication modules must be ordered separately. See Fieldbus Section for more information.

Note:

For cable part numbers and pin out information see Fieldbus System Accessories.

 Most popular.



For inventory, lead time, and kit lookup, visit www.pdnplu.com

Ordering Information

How To Order Plug-in Add-A-Fold Assemblies

1. List Add-A-Fold Assembly call out. This automatically includes the end plate kit assembly.
2. List complete Valve, Regulator, Flow Control and Base model number. List left to right, LOOKING AT THE CYLINDER PORTS on the #12 end of the manifold. The left most station is station 1. (If a blank station is needed, list the blanking plate part number and the individual manifold number in the station specified.)

Example

Application requires a 3-Station manifold with a valve and regulator on Station 3.

Item	Qty.	Part No.	Location
01	1	AAH2D003	
02	1	H21VXBG0B9D.....	Station 1
03	1	PS411157MCP.....	Station 1
04	1	H22VXBG0B9D.....	Station 2
05	1	PS411157MCP.....	Station 2
06	1	H22VXXG0B9D.....	Station 3
07	1	PS4138166CP.....	Station 3
08	1	PS411157MCP.....	Station 3

NOTE: Construct manifold assemblies from left to right while looking at the cylinder ports.
 Valves must be ordered as External Pilot when using Sandwich Regulator.

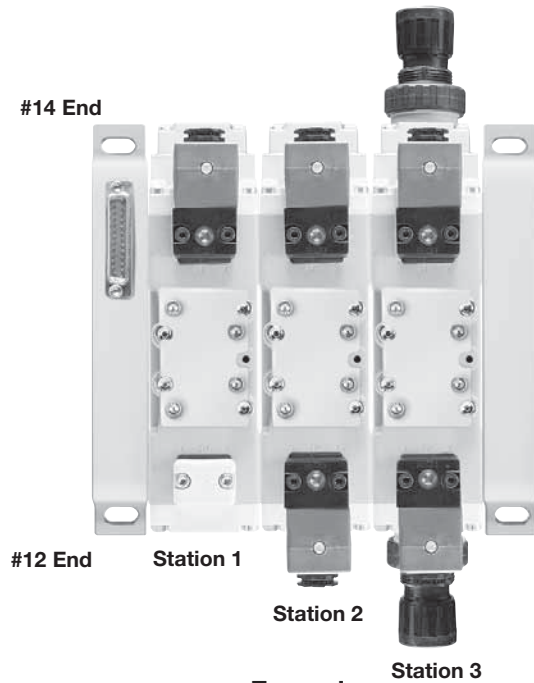

Example:
3-Station Manifold with (3) H2 Valves on Manifold Bases and Regulator at Station 3

Maximum Number of Solenoids (Maximum energized simultaneously)

Voltage	Voltage code	25-pin D-sub	19-pin M23 or		Turck			
			Brad Harrison	12-pin M23	Moduflex	H Series Fieldbus	16 Outputs	32 Outputs
24VDC	G9	24 (24)	16 (16)	8 (8)	24 (24) [†]	24 (21)	16 (16)	24 (21)
120VAC*	23	24 (24)	16 (16)	8 (8)	N/A	N/A	N/A	N/A

* Not CSA certified for 25-pin, D-Sub option.
[†] Use Type A IO-Link module for 24 outputs simultaneously.

Add-A-Fold Assembly Model Numbers

AA H2 D 0 03

Valve series	Transition Plate
Right & left end plate H2	Blank No transition plate
Right & left end plate H3	E ‡ H2 to H3
	‡ Must specify valve series H3.

End plate type	Number of stations
Turck fieldbus with valve driver module - 16 outputs	01
Turck fieldbus with valve driver module - 32 outputs	02
25-pin, D-sub	03
19-pin, brad harrison	•
12-pin, M23	•
19-pin, M23	24
Standard, non-collective wiring	
Moduflex fieldbus	
H Series Fieldbus, with valve driver module	

Thread type
0 NPT
1* BSPP "G"

* Must order communication modules separately.
[†] Collective wiring module included.
^{*} BSPP conforms to ISO 1179-1 w 228-1 threads.





Most popular.





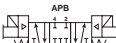

For inventory, lead times, and kit lookup, visit www.pdnplu.com

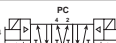
D
 Subbase & Manual Valves
 H Series Micro
 Moduflex Series
 H Series ISO
 Fieldbus Systems
 DX ISOMAX Series
 Valvair II Series

5599-2, Plug-in, Size 3 (H3)

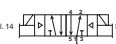
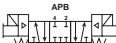
Symbol	Type	Cv	Operator	Voltage	Pilot	Non-locking	Locking
	4-way, 2-position, spring return	6.0	Single solenoid	24 VDC	Internal	H3EVXBG0B9D	H3EVXBH0B9D
					External	H3EVXXG0B9D	H3EVXXH0B9D
	4-way, 2-position, air return	6.0	Single solenoid	24 VDC	Internal	H31VXBG0B9D	H31VXBH0B9D
					External	H31VXXG0B9D	H31VXXH0B9D
	4-way, 2-position	6.0	Double solenoid	24 VDC	Internal	H32VXBG0B9D	H32VXBH0B9D
					External	H32VXXG0B9D	H32VXXH0B9D
	4-way, 3-position, all ports blocked	5.0	Double solenoid	24 VDC	Internal	H35VXBG0B9D	H35VXBH0B9D
					External	H35VXXG0B9D	H35VXXH0B9D
	4-way, 3-position, center exhaust	5.0	Double solenoid	24 VDC	Internal	H36VXBG0B9D	H36VXBH0B9D
					External	H36VXXG0B9D	H36VXXH0B9D
	4-way, 3-position, pressure center	5.0	Double solenoid	24 VDC	Internal	H37VXBG0B9D	H37VXBH0B9D
					External	H37VXXG0B9D	H37VXXH0B9D

Symbol	Type	Cv	Operator	Voltage	Pilot	Non-locking	Locking
	4-way, 2-position, spring return	6.0	Single solenoid	120 VAC	Internal	H3EVXBG023D	H3EVXBH023D
					External	H3EVXXG023D	H3EVXXH023D
	4-way, 2-position, air return	6.0	Single solenoid	120 VAC	Internal	H31VXBG023D	H31VXBH023D
					External	H31VXXG023D	H31VXXH023D
	4-way, 2-position	6.0	Double solenoid	120 VAC	Internal	H32VXBG023D	H32VXBH023D
					External	H32VXXG023D	H32VXXH023D
	4-way, 3-position, all ports blocked	5.0	Double solenoid	120 VAC	Internal	H35VXBG023D	H35VXBH023D
					External	H35VXXG023D	H35VXXH023D
	4-way, 3-position, center exhaust	5.0	Double solenoid	120 VAC	Internal	H36VXBG023D	H36VXBH023D
					External	H36VXXG023D	H36VXXH023D
	4-way, 3-position, pressure center	5.0	Double solenoid	120 VAC	Internal	H37VXBG023D	H37VXBH023D
					External	H37VXXG023D	H37VXXH023D

5599-2, Plug-in Single Subbase, Size 3 (H3)

Side ported base	Enclosure / Lead length	Solenoid addresses	3/4" NPT	3/4" BSPP
	Terminal strip in base	Double solenoid - 2 address	PS421119CCP	PS401110CCP
	6" flying leads	Double solenoid - 2 addresses	PS421119ACP	PS421110ACP

5599-2, Plug-in Manifold Bases, Size 3 (H3)

Bottom / End ported bases	Enclosure / Lead length	Solenoid addresses	3/4" NPT	3/4" BSPP
	Circuit board	Single solenoid - 1 address	PS421169JDP	PS421160JDP
	Circuit board	Double solenoid - 2 addresses	PS421169MCP	PS421160MCP
	Terminal strip in base	Double solenoid - 2 address	PS421169CCP	PS421160CCP
	6" flying leads	Double solenoid - 2 addresses	PS421169ACP	PS421160ACP
End Ported	Circuit board	Single solenoid - 1 address	PS421159JCP	PS421150JCP
	Circuit board	Double solenoid - 2 addresses	PS421159MCP	PS421150MCP
	Terminal strip in base	Double solenoid - 2 address	PS421159CCP	PS421150CCP
	6" flying leads	Double solenoid - 2 addresses	PS421159ACP	PS421150ACP

 Most popular.



For inventory, lead time, and kit lookup, visit www.pdnplu.com

D91

Parker Hannifin Corporation
Pneumatic Division
Richland, Michigan
www.parker.com/pneumatics

D

Subbase & Manual Valves

H Series Micro

Moduflex Series





H Series ISO

Fieldbus Systems





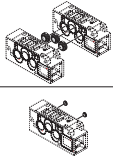

DX ISOMAX Series

Valvair II Series

5599-2, Size 3 (H3) Accessories

Accessory	Description	Part number
 Sandwich regulator	Common pressure 5-125 PSIG w/ gauge	PS4238166CP
	Independent pressure 5-125 PSIG w/ gauge	PS4238266CP
 Blanking plate kit		PS4234CP
 Sandwich flow control	A Sandwich Flow Control and Common Port Sandwich Regulator may be sandwiched together on a manifold or subbase. The Sandwich Flow Control MUST be located between the manifold/subbase and the Common Port Sandwich Regulator.	PS4235CP
 Manifold to manifold gasket kits		PS4213P
 Manifold port isolation kit	Main galley (1, 3, 5)	PS4232CP
	Pilot galley	PS4033CP

Plug-in, 5599-2 End Plate Kits, Size 3 (H3)

Electrical option	NPT port	BSPP port
 No connector - use with individually wired base	PS4231010DP	PS4231011DP
 25-pin, D-sub	PS4220L20DP	PS4220L21DP
 19-pin, round, Brad Harrison	PS4220L30DP	PS4220L31DP
 12-pin, M23	PS4220L40DP	PS4220L41DP
	19-pin, M23	PS4220M20DP
 Moduflex fieldbus	PS4220M40DP	PS4220M41DP
 H Series Fieldbus, with valve driver module	PS4220L60DP	PS4220L61DP
 Turck fieldbus with valve driver module - 16 outputs	PS4220T10DP	PS4220T11DP
	Turck fieldbus with valve driver module - 24 outputs	PS4220T20DP

Turck, H Series Fieldbus, and Moduflex communication modules must be ordered separately. See Fieldbus Section for more information.

Note:

For cable part numbers and pin out information see Fieldbus System Accessories.

 Most popular.



For inventory, lead times, and kit lookup, visit www.pdnplu.com

D92

Parker Hannifin Corporation
Pneumatic Division
Richland, Michigan
www.parker.com/pneumatics

D
 Subbase & Manual Valves
 H Series Micro
 Moduflex Series
 H Series ISO
 Fieldbus Systems
 DX ISOMAX Series
 Valvair II Series

How To Order Plug-in Add-A-Fold Assemblies

1. List Add-A-Fold Assembly call out. This automatically includes the end plate kit assembly.
2. List complete Valve, Regulator, Flow Control and Base model number. List left to right, LOOKING AT THE CYLINDER PORTS on the #12 end of the manifold. The left most station is station 1. (If a blank station is needed, list the blanking plate part number and the individual manifold number in the station specified.)

Example

Application requires a 3-Station manifold with a valve and regulator on Station 3.

Item	Qty.	Part No.	Location
01	1	AAH3D003	
02	1	H31VXBG0B9D.....	Station 1
03	1	PS421159MCP.....	Station 1
04	1	H32VXBG0B9D.....	Station 2
05	1	PS421159MCP.....	Station 2
06	1	H32VXXG0B9D.....	Station 3
07	1	PS4238166CP.....	Station 3
08	1	PS421159MCP.....	Station 3

NOTE: Construct manifold assemblies from left to right while looking at the cylinder ports.
 Valves must be ordered as External Pilot when using Sandwich Regulator.

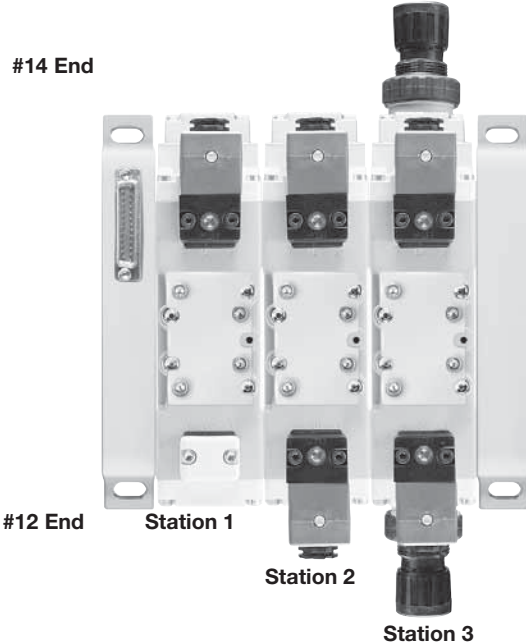

Example:
3-Station Manifold with (3) H3 Valves on Manifold Bases and Regulator at Station 3

Maximum Number of Solenoids (Maximum energized simultaneously)

Voltage	Voltage code	19-pin M23 or		12-pin M23	Moduflex	Turck	
		25-pin D-sub	Brad Harrison			H Series 16	32
24VDC	G9	24 (24)	16 (16)	8 (8)	24 (24) [†]	24 (21)	16 (16) 24 (21)
120VAC*	23	24 (24)	16 (16)	8 (8)	N/A	N/A	N/A

* Not CSA certified for 25-pin, D-Sub option.
[†] Use Type A IO-Link module for 24 outputs simultaneously.

Add-A-Fold Assembly Model Numbers

AA H3 D 0 03

Valve series Right & left end plate H3	Number of stations 01 02 03 04 • • 24
End plate type Turck fieldbus with valve driver module - 16 outputs A* Turck fieldbus with valve driver module - 32 outputs B* 25-pin, D-sub D [†] 19-pin, brad harrison E [†] 12-pin, M23 G [†] 19-pin, M23 H [†] Standard, non-collective wiring S Moduflex fieldbus T* H Series Fieldbus, with valve driver module Y*	Thread type 0 NPT 1* BSPP "G"

* Must order communication modules separately.
[†] Collective wiring module included.

Most popular.



For inventory, lead time, and kit lookup, visit www.pdnplu.com

Plug-in, 5599-2, Size 1, 2, & 3

H1 E VX B G O B9 D

Basic series 5599-2	
ISO 5599-2 Size 1	H1
ISO 5599-2 Size 2	H2
ISO 5599-2 Size 3	H3

5599-2 Engineering level	
D	Current

5599-2 Operator / Function	
Single solenoid, 2-position - air return	1
Double solenoid, 2-position	2
Double solenoid, 3-position - APB	5
Double solenoid, 3-position - CE	6
Double solenoid, 3-position - PC	7
Single solenoid, 2-position - air return, spring assist	E

5599-2 Voltage & Frequency				
	AC		DC	Light & surge suppression
	60Hz	50Hz		
42	24			
45			12	
B9			24	LED & suppression
23	120	115		LED & suppression
57	240			

5599-2 Mounting	
5599-2 Valve less vase	VX

5599-2 Enclosure / Lead length	
0	None, valve less base

5599-2 Pilot source / Pilot exhaust	
Internal pilot, port #1 / vented	B
External pilot, port #12 or #14 / vented	X*

* Must be specified when using Sandwich Regulators.

5599-2 Overrides / Lights		
	Voltage code	
B	42, 45, 57	Non-locking, flush, push - w/o light
C	42, 45, 57	Locking, flush, push / turn - w/o light
G	B9, 23	Non-locking, flush, push - w/ light
H	B9, 23	Locking, flush, push / turn - w/ light

D

Subbase & Manual Valves

H Series Micro

Modulflex Series

H Series ISO

Fieldbus Systems

DX ISOMAX Series

Valvair II Series



For inventory, lead times, and kit lookup, visit www.pdnplu.com

Plug-in, 5599-2, Size 1, 2 & 3 Manifold / Subbase Kits

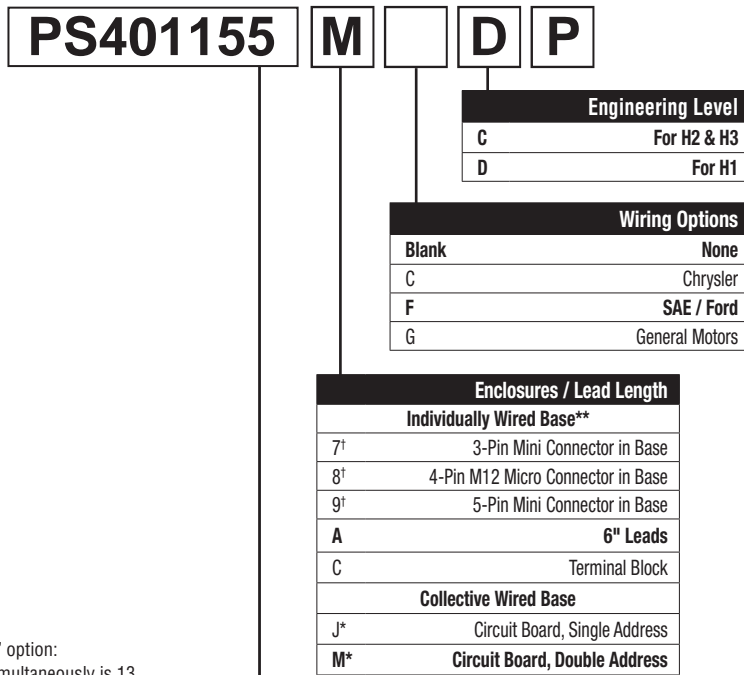

Note:
 When using the Enclosure / Lead Length "J" or "M" option:
 12VDC - Maximum number of coils energized simultaneously is 13
 24VDC - Maximum number of coils energized simultaneously is 21
 120VAC - Coils limited by the number of pins available in the connector
 (25-Pin D-Sub = 24 coils, 19-Pin Brad Harrison = 16, 12-Pin M23 = 8)
 240VAC - Must use "A" or "C" Option, Lead Wires or Terminal Blocks

* Not Available with Subbase Kits.
 ** Use Plate with No Connection.
 † Must Specify Valve Auto Wiring Option "C", "F", or "G".

Mounting Base Style / Port Size		ISO 5599-2, Size 1 H1 Series		ISO 5599-2, Size 2 H2 Series		ISO 5599-2, Size 3 H3 Series	
Subbase: 3/8 NPT Side Ports	PS401115	Subbase: 1/2 NPT Side Ports	PS411117	Subbase: 3/4 NPT Side Ports	PS421119	Subbase: 3/8 BSPP Side Ports	PS401116
Manifold: 3/8 NPT End Ports	PS401155	Manifold: 1/2 NPT End Port	PS411157	Manifold: 3/4 NPT End Port	PS421159	Manifold: 1/2 BSPP Side Ports	PS411118*
Manifold: 3/8 BSPP End Ports	PS401156*	Manifold: 1/2 BSPP End Ports	PS411158*	Manifold: 3/4 BSPP End Port	PS421150*	Manifold: 1/2 NPT Bottom / End Port	PS411167
Manifold: 3/8 NPT Bottom / End Port	PS401165†	Manifold: 1/2 NPT Bottom / End Port	PS411167	Manifold: 3/4 BSPP Bottom / End Port	PS421169	Manifold: 3/8 BSPP Bottom / End Port	PS401166*†
Manifold: 3/8 BSPP Bottom / End Port	PS401166*†	Manifold: 1/2 BSPP Bottom / End Port	PS411168*	Manifold: 3/4 BSPP Bottom / End Port	PS421160*		

* BSPP Conforms to ISO 1179-1 w 228-1 Threads.
 † #1 Bottom Port - 1/4".

Subbase Kits

Manifold Kits

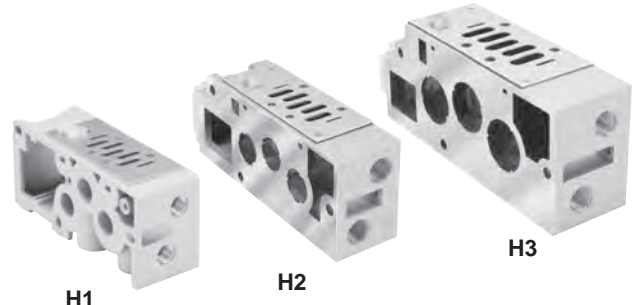
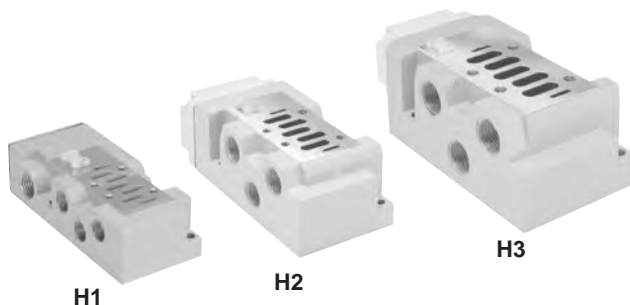

Automotive Connectors
 Mounted in 1/2" Conduit Port

- 3-Pin - Wired for Single Solenoid
- 4-Pin / 5-Pin - Wired for Double Solenoid

Automotive Connectors
 Mounted in Individual Manifold Conduit Cover

- 3-Pin - Wired for Single Solenoid
- 4-Pin / 5-Pin - Wired for Double Solenoid



For inventory, lead time, and kit lookup, visit www.pdnplu.com

D95

Parker Hannifin Corporation
 Pneumatic Division
 Richland, Michigan
www.parker.com/pneumatics

D

Subbase & Manual Valves

H Series Micro

Modulflex Series

H Series ISO

Fieldbus Systems

DX ISOMAX Series

Valvair II Series

Plug-in, 5599-2 End Plate Kits

PS40 20L2 0 D P

Basic Series	
ISO 5599, Size 1	PS40
ISO 5599, Size 2	PS41
ISO 5599, Size 3	PS42

Engineering Level	
D	Current

Thread Type	
0	NPT
1*	BSPG "G"

* BSPP Conforms to ISO 1179-1 w 228-1 Threads

Options †	
25-Pin, D-Sub	20L2*
19-Pin, Round, Brad Harrison	20L3
12-Pin, M23	20L4
19-Pin, M23	20M2
Moduflex Fieldbus	20M4
H Series Fieldbus, with Valve Driver Module	20L6
Turck Fieldbus with Valve Driver Module - 16 Outputs	20T1
Turck Fieldbus with Valve Driver Module - 24 Outputs	20T2

* 120VAC is Not CSA Rated.

† Manifold bases must have a circuit board.

Turck, H Series Fieldbus, and Moduflex communication modules must be ordered separately. See Fieldbus Section for more information.

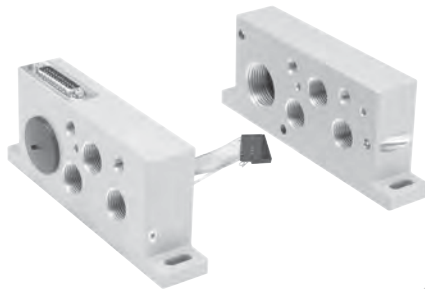

L2: H1 25-Pin D-Sub End Plates



L4 or M2: H1, M23, 12-Pin or 19-Pin End Plates

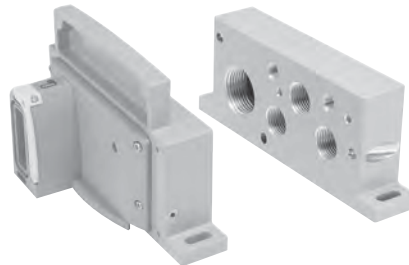

M4: H1 Moduflex Fieldbus End Plates



L3: H1 19-Pin Brad Harrison End Plates

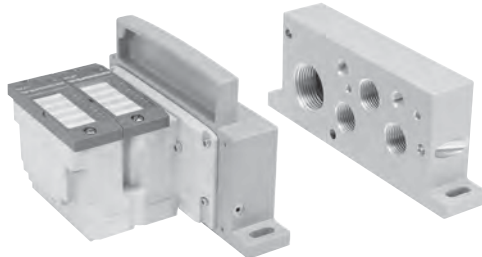

T1, T2: Turck Fieldbus with Valve Driver Module End Plates

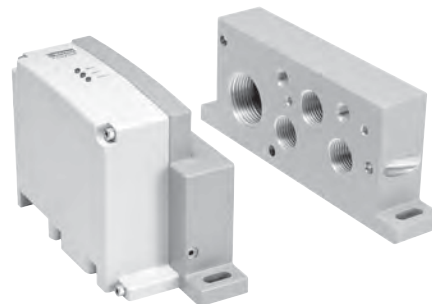

L6: H1 H Series Fieldbus End Plates

D
 Subbase & Manual Valves
 H Series Micro
 Moduflex Series
 H Series ISO
 Fieldbus Systems
 DX ISOMAX Series
 Valvair II Series



For inventory, lead times, and kit lookup, visit www.pdnplu.com

D96

Parker Hannifin Corporation
 Pneumatic Division
 Richland, Michigan
www.parker.com/pneumatics

Plug-in, 5599-2 Transition Plate Kits

PS4026 L2 0 C P

Transition plate type*	
H1 to H2 to H3	PS4025
H1 to H3	PS4026
H1 to H2	PS4027
H2 to H3	PS4028

* Includes Left Hand and Right Hand End Plates

Engineering level	
C	Basic series PS40

Thread type	
0	NPT
1*	BSPP "G"

* BSPP conforms to ISO 1179-1 w 228-1 threads.

Options	
25-pin, D-sub	L2
19-pin, round, brad harrison	L3
12-pin, M23	L4
19-pin, M23	M2
Moduflex fieldbus	M4*
H Series Fieldbus, with valve driver module	L6*
Turck fieldbus with valve driver module - 16 outputs	T1
Turck fieldbus with valve driver module - 32 outputs	T2

* Must order communication module separately
 turck, H Series Fieldbus, and moduflex communication modules must be ordered separately.
 See fieldbus section for more information.



D	Subbase & Manual Valves
	H Series Micro
	Moduflex Series
	H Series ISO
	Fieldbus Systems
DX ISOMAX Series	
Valvair II Series	



For inventory, lead time, and kit lookup, visit www.pdnplu.com

Plug-in, 5599-2, Sandwich Regulators

PS4038 1 6 6 C P

Basic Series	
H1	
5599-2, Plug-in	PS4038
H2	
5599-2, Plug-in	PS4138
H3	
5599-2, Plug-in	PS4238

Regulator Function	
Common Pressure Regulator	1
Independent Pressure Regulator	2

#2 Port Regulator / Gauge*	
0**	Line By-Pass Plate
4	1-30 PSIG w/Gauge
5	2-60 PSIG w/Gauge
6	5-125 PSIG w/Gauge
D	Remote Pilot ISO 2 & 3 only

* For Common Pressure Regulator Option, Regulator Gauge callout must be the same number for both Port #4 and Port #2. (Example: 166)

** Pressure Line By-Pass Option can only be used with Independent Pressure Regulators.

#4 Port Regulator / Gauge*	
0**	Line By-Pass Plate
4	1-30 PSIG w/Gauge
5	2-60 PSIG w/Gauge
6	5-125 PSIG w/Gauge
D	Remote Pilot ISO 2 & 3 only

* For Common Pressure Regulator Option, Regulator Gauge callout must be the same number for both Port #4 and Port #2. (Example: 166)

** Pressure Line By-Pass Option can only be used with Independent Pressure Regulators.

Ordering Components

- Sandwich Regulator Kit configured for Internal Pilot as standard.
- Order valve as External Pilot.

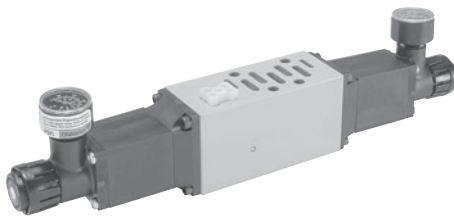

H1 - Size 1
 (Independent Dual Port Regulator Shown)

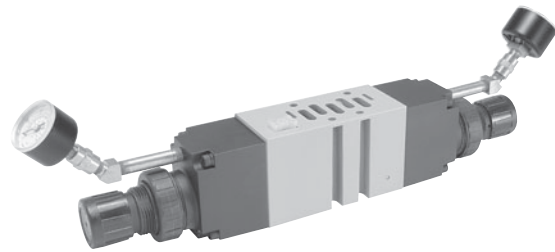

H2 - Size 2
 (Independent Dual Port Regulator Shown)

How to Configure Sandwich Regulator / Valve Combinations

Internal Pilot Configuration of Sandwich Regulator H1, H2 & H3

Pressure in Base Port 1 feeds regulator configured for Internal Pilot which feeds valve configured for External Pilot.

External Pilot Configuration of Sandwich Regulator H1, H2, H3

An External Pilot pressure in Port 12 or 14 of the base feeds thru the Sandwich Regulator 12 or 14 galley directly to the 12/14 pilot of the valve. This configuration takes an External Pilot from the 12 port of the base and passes it thru the regulator to feed the 12 galley of the valve.

Sandwich Regulator Cv Flow Chart*

	Common Pressure Code 166				Single Pressure 2 Code 206				Single Pressure 4 Code 260				Dual Pressure Code 266			
	1-2	1-4	2-3	4-5	1-2	1-4	2-3	4-5*	1-2	1-4	2-3	4-5*	1-2	1-4	2-3	4-5*
H1	0.62	0.61	1.28	1.18	0.73	0.96	0.96	0.93	0.34	0.70	0.94	0.98	0.52	0.48	0.86	0.88
H2	1.47	1.60	2.41	2.33	1.71	1.90	1.52	1.75	1.74	1.67	1.73	1.79	1.61	1.62	1.50	1.67
H3	2.37	2.39	4.30	4.47	2.37	2.81	2.75	3.01	2.65	2.59	2.68	2.74	2.43	2.41	3.16	3.04

* Regulator Port exhaust through Base Port 3.

Note: All Cv's calculated with regulator adjusted full open.

D

Subbase & Manual Valves

H Series Micro

Modulflex Series

H Series ISO

Fieldbus Systems

DX ISOMAX Series

Valvair II Series



For inventory, lead times, and kit lookup, visit www.pdnplu.com

D98

Parker Hannifin Corporation
 Pneumatic Division
 Richland, Michigan
www.parker.com/pneumatics

Plug-in, H1, H2, H3 Common Port Regulation

Provides adjustable regulated air pressure to the valve's #1 port which gives the same regulated pressure to both the #2 and #4 port of the manifold or subbase. The regulator is always on the 14 end of the valve.

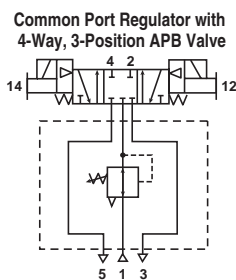
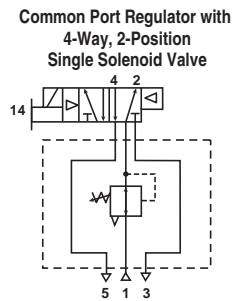

H2 Common Port Regulator Shown - Double Solenoid, 14 Energized, Internal Pilot

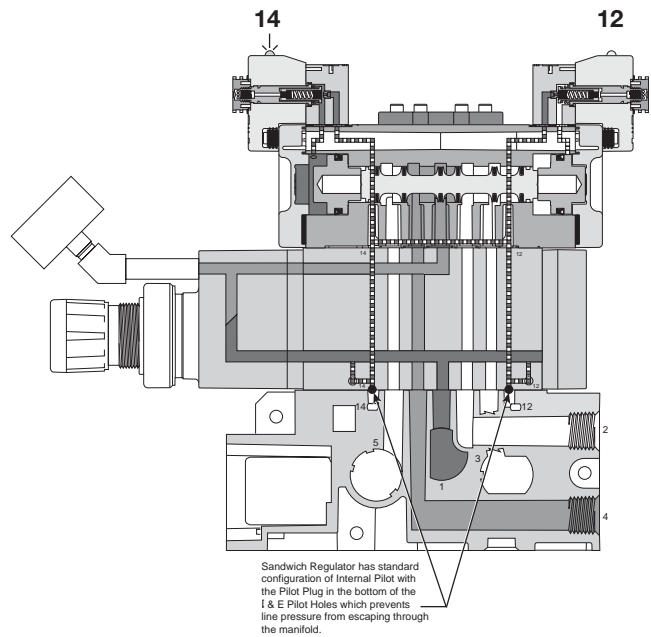

Plug-in, H1, H2, H3 Independent Port Regulation

Single Port Regulator

Provides regulated pressure to one of the ports and full line pressure to the other by use of the Line Pressure By-Pass Plate. Pressure regulation can occur out of the #4 port of the valve.

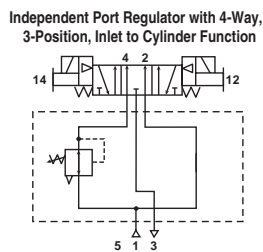
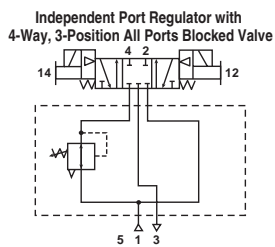

CAUTION: Requires 4-Way, 3-Position, Cylinder to Exhaust Valve

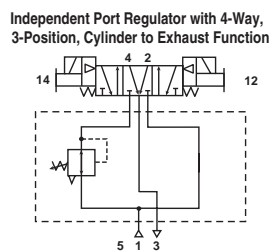

CAUTION: Requires 4-Way, 3-Position, Inlet to Cylinder Valve

H1 Independent Port Regulator Shown - Double Solenoid, De-energized, Internal Pilot

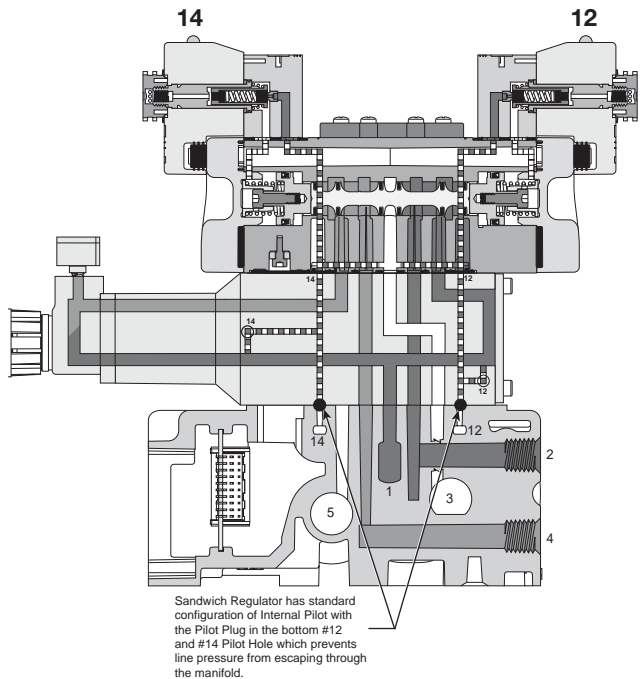

D	Subbase & Manual Valves
	H Series Micro
	Modulflex Series
	H Series ISO
	Fieldbus Systems
	DX ISOMAX Series
	Valvair II Series

When using an Independent Pressure Sandwich Regulator, the cylinder outlet ports are reversed. The 12 end energizes the #4 port and the 14 end energizes the #2 port. The 3-Position CE and PC functions are also reversed. (See schematics above.)



For inventory, lead time, and kit lookup, visit www.pdnplu.com

Plug-in, H1, H2, H3 Independent Dual Port Regulation

Dual Port Regulator

Provides regulated pressure to both ports. Pressure regulation can occur out of the #2 or #4 port of the valve.

H1 Independent Dual Port Regulator Shown - Double Solenoid, 14 Energized, Internal Pilot

Independent Dual Port Regulator with 4-Way, 2-Position Double Solenoid Valve

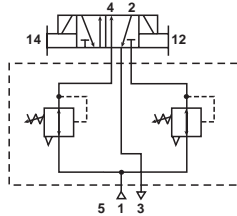

Independent Dual Port Regulator with 4-Way, 3-Position Double Solenoid Valve

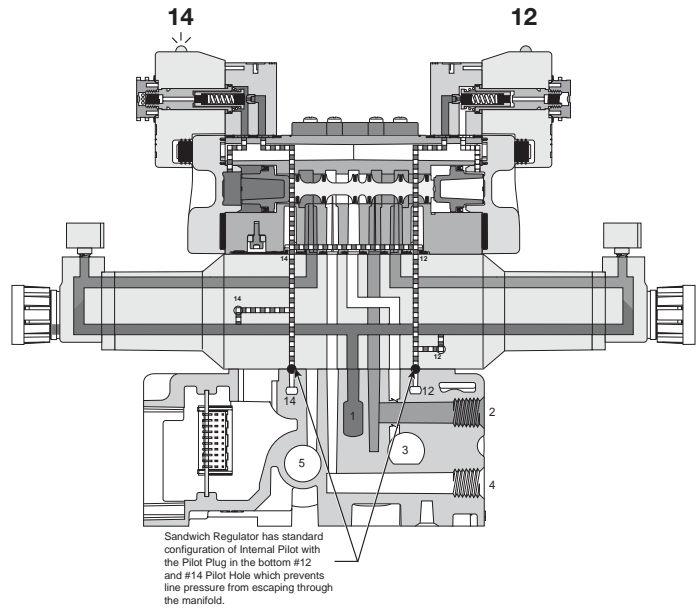
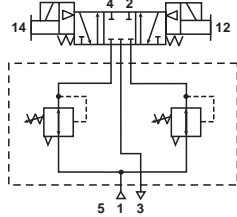



When using an Independent Pressure Sandwich Regulator, the cylinder outlet ports are reversed. The 12 end energizes the #4 port and the 14 end energizes the #2 port. The 3-Position CE and PC functions are also reversed. (See schematics on above.)

D	Subbase & Manual Valves
	H Series Micro
	Modutflex Series
	H Series ISO
	Fieldbus Systems
	DX ISOMAX Series
Valvair II Series	



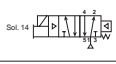
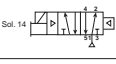
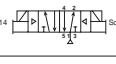
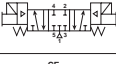
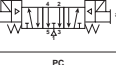
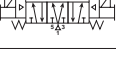
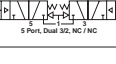

For inventory, lead times, and kit lookup, visit www.pdnplu.com

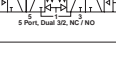





15407-1, Non Plug-in, Size 18mm (HB)

Symbol	Type	Cv	Operator	Voltage	Pilot	Non-locking	Locking
	4-way, 2-position, spring return	0.55	Single solenoid	24 VDC	Internal	HBEWXBG2G9000FA	HBEWXBH2G9000FA
					External	HBEWXLG2G9000FA	HBEWXLH2G9000FA
	4-way, 2-position, air return	0.55	Single solenoid	24 VDC	Internal	HB1WXBG2G9000FA	HB1WXBH2G9000FA
					External	HB1WXLG2G9000FA	HB1WXLH2G9000FA
	4-way, 2-position	0.55	Double solenoid	24 VDC	Internal	HB2WXBG2G9000FA	HB2WXBH2G9000FA
					External	HB2WXLG2G9000FA	HB2WXLH2G9000FA
	4-way, 3-position, all ports blocked	0.5	Double solenoid	24 VDC	Internal	HB5WXBG2G9000FA	HB5WXBH2G9000FA
					External	HB5WXLG2G9000FA	HB5WXLH2G9000FA
	4-way, 3-position, center exhaust	0.5	Double solenoid	24 VDC	Internal	HB6WXBG2G9000FA	HB6WXBH2G9000FA
					External	HB6WXLG2G9000FA	HB6WXLH2G9000FA
	4-way, 3-position, pressure center	0.5	Double solenoid	24 VDC	Internal	HB7WXBG2G9000FA	HB7WXBH2G9000FA
					External	HB7WXLG2G9000FA	HB7WXLH2G9000FA
	3-way, 2-position, dual valve, NC/NC	0.45	Double solenoid	24 VDC	Internal	HBNWXBG2G9000FA	HBNWXBH2G9000FA
					External	HB7WXLG2G9000FA	HB7WXLH2G9000FA
	3-way, 2-position, dual valve, NO/NO	0.45	Double solenoid	24 VDC	Internal	HBPWXBG2G9000FA	HBPWXBH2G9000FA
					External	HB7WXLG2G9000FA	HB7WXLH2G9000FA
	3-way, 2-position, dual valve, NC/NO	0.45	Double solenoid	24 VDC	Internal	HBQWXBG2G9000FA	NA
					External	HB7WXLG2G9000FA	HB7WXLH2G9000FA

15407-1, Non Plug-in, Size 18mm (HB)

2 Station manifold bases	Description	1/8" NPT	1/8" BSPP
	End ported bases	PS5611510P	PS5611520P
	Bottom / end port	PS5611610P	PS5611620P
End plate kit	Description	NPT port	BSPP port
	Non-collective wiring end plate	PS5631010P	PS5631011P

15407-1, Non-Plug-in, Size 18mm (HB) Accessories

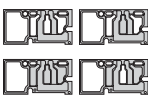
Accessories	Description	Part number
	Common pressure	2-60 PSIG w/ gauge PS5637155P
	Common pressure	5-125 PSIG w/ gauge PS5637166P
	Independent pressure	2-60 PSIG w/ gauge PS5637255P
	Independent pressure	5-125 PSIG w/ gauge PS5637266P
	Gauge adapter kit	Includes 1/8" coupling and long nipple PS5651160P
	Blanking plate kit	PS5634P
	1/8" NPT	PS562600P
	1/8" BSPP	PS562601P
	1/8" NPT	PS562700P
	1/8" BSPP	PS562701P
	Intermediate air supply module	1/8" NPT D02P-01-80
	Sandwich flow control	PS5642P
	Standard	PS561AP
	Blocked #1 port	PS561BP
	Blocked #1, 3, 5, ports	PS561CP
	Blocked #3, 5 ports	PS561DP

 Most popular.



For inventory, lead time, and kit lookup, visit www.pdnplu.com

D101

Parker Hannifin Corporation
Pneumatic Division
Richland, Michigan
www.parker.com/pneumatics

D

Subbase & Manifold Valves

H Series Micro

Moduflex Series





H Series ISO

Fieldbus Systems

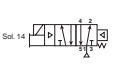
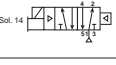

DX ISOMAX Series

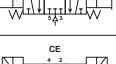
Valvair II Series







15407-1, Non Plug-in, Size 26mm (HA)

Symbol	Type	Cv	Operator	Voltage	Pilot	Non-locking	Locking
	4-way, 2-position, spring return	1.1	Single solenoid	24 VDC	Internal	HAEWXBG2G9000FA	HAEWXBH2G9000FA
					External	HAEWXLG2G9000FA	HAEWXLH2G9000FA
	4-way, 2-position, air return	1.1	Single solenoid	24 VDC	Internal	HA1WXBG2G9000FA	HA1WXBH2G9000FA
					External	HA1WXLG2G9000FA	HA1WXLH2G9000FA
	4-way, 2-position	1.1	Double solenoid	24 VDC	Internal	HA2WXBG2G9000FA	HA2WXBH2G9000FA
					External	HA2WXLG2G9000FA	HA2WXLH2G9000FA
	4-way, 3-position, all ports blocked	1.0	Double solenoid	24 VDC	Internal	HA5WXBG2G9000FA	HA5WXBH2G9000FA
					External	HA5WXLG2G9000FA	HA5WXLH2G9000FA
	4-way, 3-position, center exhaust	1.0	Double solenoid	24 VDC	Internal	HA6WXBG2G9000FA	HA6WXBH2G9000FA
					External	HA6WXLG2G9000FA	HA6WXLH2G9000FA
	4-way, 3-position, pressure center	1.0	Double solenoid	24 VDC	Internal	HA7WXBG2G9000FA	HA7WXBH2G9000FA
					External	HA7WXLG2G9000FA	HA7WXLH2G9000FA

15407-1, Non Plug-in, Size 26mm (HA)

Single subbase	Description	1/4" NPT	1/4" BSPP
	Side ported base	PS551130P	PS551140P
2 Station manifold bases	Description	1/4" NPT	1/4" BSPP
	End ported bases	PS5511530P	PS5511540P
	Bottom / end port	PS5511630P	PS5511640P
End plate kit	Description	NPT port	BSPP port
	Non-collective wiring end plate	PS5631010P	PS5631011P

15407-1, Non-Plug-in, Size 26mm (HA) Accessories

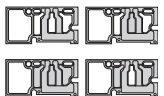
Accessories	Description	Part number
	Common pressure	2-60 PSIG w/ gauge PS5537155P
	Common pressure	5-125 PSIG w/ gauge PS5537166P
	Independent pressure	2-60 PSIG w/ gauge PS5537255P
	Independent pressure	5-125 PSIG w/ gauge PS5537266P
	Gauge adapter kit	Includes 1/8" coupling and long nipple PS5651160P
	Blanking plate kit	PS5534P
	1/4" NPT	PS552600P
	1/4" BSPP	PS552601P
	1/4" NPT	PS552700P
	1/4" BSPP	PS552701P
	Intermediate air supply module	1/4" NPT D01P-02-80
	Sandwich flow control	PS5542P
	Sandwich Flow Control and Common Port Sandwich Regulator may be sandwiched together on a manifold or subbase. The Sandwich Flow Control MUST be located between the manifold/subbase and the Common Port Sandwich Regulator.	
	Standard	PS561AP
	Blocked #1 port	PS561BP
	Blocked #1, 3, 5, ports	PS561CP
	Blocked #3, 5 ports	PS561DP

 Most popular.

D
 Subbase & Manual Valves
 H Series Micro
 Modutrex Series
 H Series ISO
 Fieldbus Systems
 DX ISOMAX Series
 Valvair II Series



For inventory, lead times, and kit lookup, visit www.pdnplu.com

D102

Parker Hannifin Corporation
Pneumatic Division
Richland, Michigan
www.parker.com/pneumatics

Non Plug-in, 15407-1, Size 18mm (HB) & 26mm (HA)

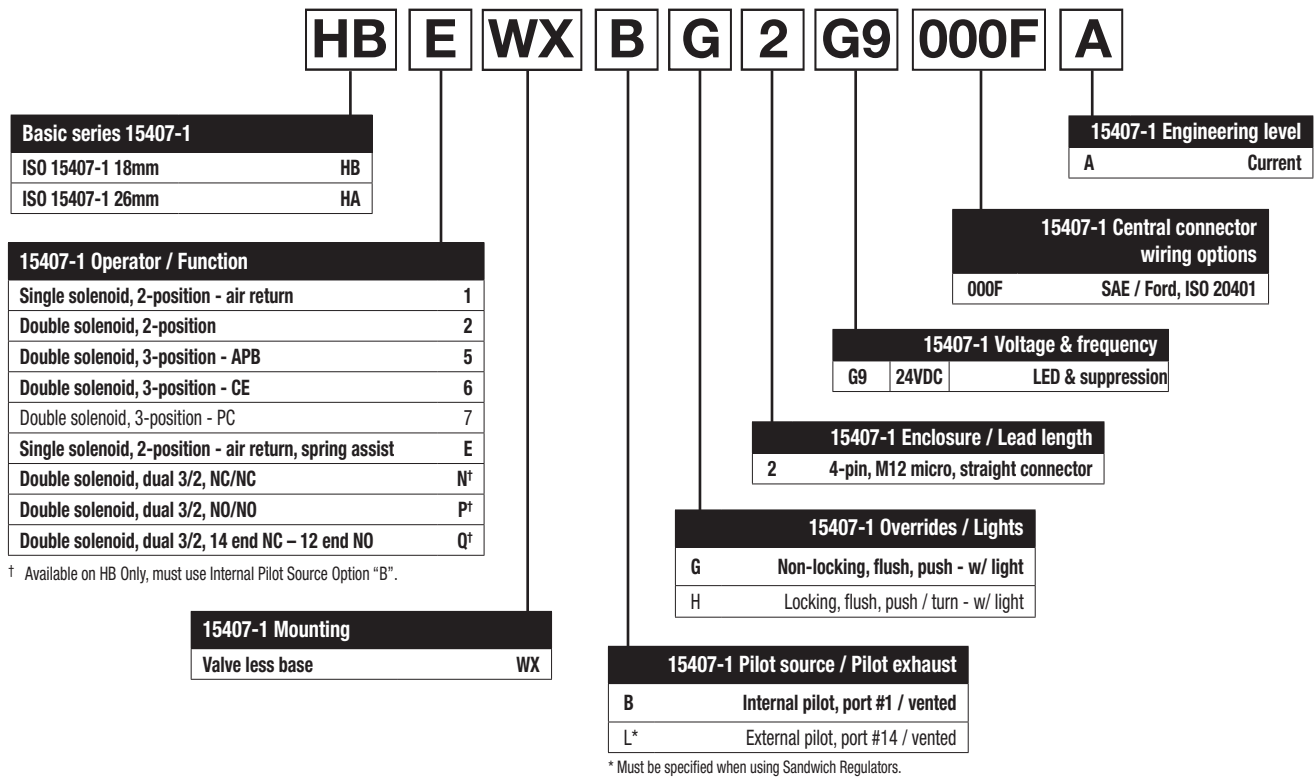

How To Order 15407-1 Non Plug-in Add-A-Fold Assemblies

1. List Add-A-Fold Assembly call out. This automatically includes the end plate kit assembly.
2. List complete Valve, Regulator, Flow Control and Base model number. List left to right, LOOKING AT THE CYLINDER PORTS on the #12 end of the manifold. The left most station is station 1. (If a blank station is needed, list the blanking plate part number and the individual manifold number in the station specified.)

Add-A-Fold Assembly Model Number

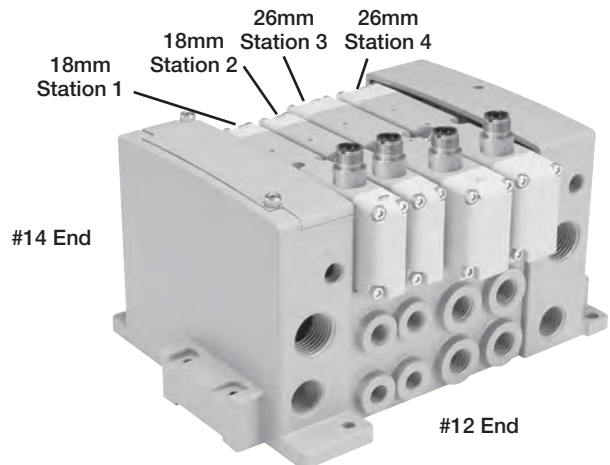
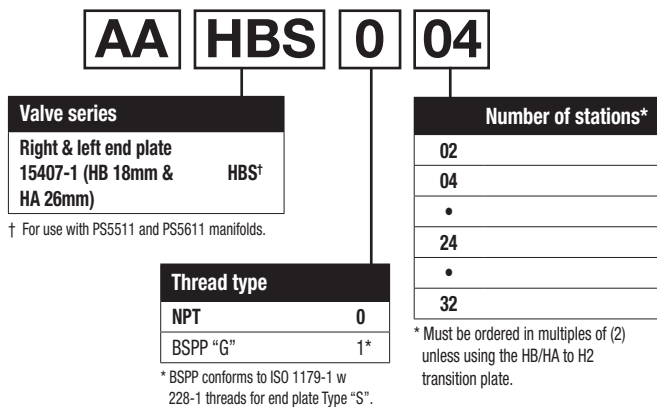

Example:
 4-Station Manifold with (2) 18mm and (2) 26mm Valves on Manifold Bases

Example

Application requires a 4-Station manifold. (Two 18mm + Two 26mm Stations)

Item	Qty.	Part No.	Location
01	1	AAHBS004	
02	1	1HB1WXBG2G9000FA	Station 1
03	1	1HB2WXBG2G9000FA	Station 2
04	1	1PS5611510P	Station 1 & 2
05	2	2HA1WXBG2G9000FA	Station 3 & 4
06	1	1PS5511510P	Station 3 & 4

NOTE: Construct manifold assemblies from left to right while looking at the ports. Valves must be ordered as External Pilot when using Sandwich Regulator.



For inventory, lead time, and kit lookup, visit www.pdnplu.com

Non Plug-in, 15407-1, Size 18mm (HB) & 26mm (HA) Manifold / Subbase Kits

PS561151 **0** **P**

Enclosures / Lead Length	
0	None, No Electrical Plug - 15407-1

Mounting Style / Port Size			
ISO 15407-1, 18mm, HB		15407-1, 26mm, HA	
Manifold with 1/8 NPT End Ports	PS561151	Subbase with 1/4 NPT Side Ports	PS551113
Manifold with 1/8 BSPP End Port	PS561152*	Subbase with 1/4 BSPP Side Ports	PS551114*
Manifold with 1/8 NPT Bottom / End Port	PS561161	Subbase with 1/4 NPT Bottom / Side Port	PS551123
Manifold with 1/8 BSPP Bottom / End Port	PS561162*	Subbase with 1/4 BSPP Bottom / Side Port	PS551124*
		Manifold with 1/4 NPT End Port	PS551153
		Manifold with 1/4 BSPP End Port	PS551154*
		Manifold with 1/4 NPT Bottom / End Port	PS551163
		Manifold with 1/4 BSPP Bottom / End Port	PS551164*

* BSPP Conforms to ISO 1179-1 w 228-1 Threads.

Subbase Kits

Manifold Kits



HA



HB



HA

Non-Plug-in, 15407-1, Size 18mm (HB) & 26mm (HA) End Plate Kits

PS563101 **0** **P**

Basic Series	
ISO 15407, Size HB, 18mm & HA, 26mm End Plate, Non-Collective Wiring	PS563101

Thread Type	
0	NPT
1*	BSPP "G"

* BSPP Conforms to ISO 1179-1 w 228-1 Threads.

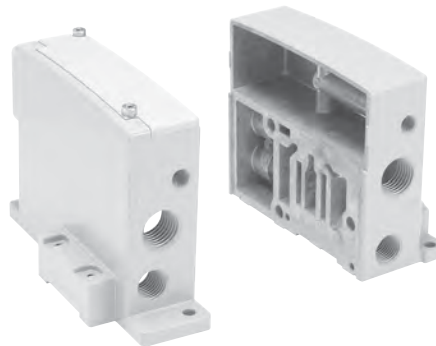

HB - HA Non-Collective Wiring End Plates



For inventory, lead times, and kit lookup, visit www.pdnplu.com

D104

Parker Hannifin Corporation
 Pneumatic Division
 Richland, Michigan
www.parker.com/pneumatics

D
 Subbase & Manual Valves
 H Series Micro
 Moduteflex Series
 H Series ISO
 Fieldbus Systems
 DX ISOMAX Series
 Valvair II Series

Non Plug-in, 15407-1, Sandwich Regulators

PS5637 1 6 6 P

Basic Series	
HB	
15407-1, 18mm, Non Plug-In	PS5637
HA	
15407-1, 26mm, Non Plug-In	PS5537

#2 Port Regulator / Gauge*	
5	2-60 PSIG w/Gauge
6	5-125 PSIG w/Gauge

* For Common Pressure Regulator Option, Regulator Gauge callout must be the same number for both Port #4 and Port #2. (Example: 166)

Regulator Function	
Common Pressure Regulator	1
Independent Pressure Regulator	2

#4 Port Regulator / Gauge*	
5	2-60 PSIG w/Gauge
6	5-125 PSIG w/Gauge

* For Common Pressure Regulator Option, Regulator Gauge callout must be the same number for both Port #4 and Port #2. (Example: 166)

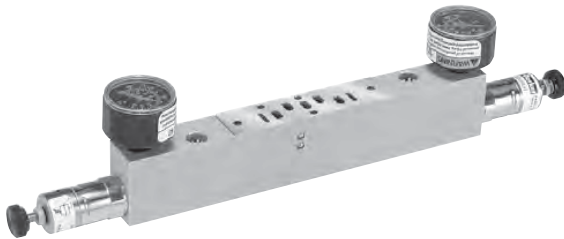

HB - 18mm
 (Independent Dual Port Regulator Shown)



HA - 26mm
 (Common Port Regulator Shown)

Ordering Components

- Manifold or Subbase Kit required.
- Sandwich Regulator Kit configured for Internal Pilot as standard.
- Order valve as External Pilot.

How to Configure Sandwich Regulator / Valve Combinations

Internal Pilot Configuration of Sandwich Regulator HA, HB

Pressure in Base Port 1 feeds regulator configured for Internal Pilot which feeds valve configured for External Pilot.



For inventory, lead time, and kit lookup, visit www.pdnplu.com

D105

Parker Hannifin Corporation
 Pneumatic Division
 Richland, Michigan
www.parker.com/pneumatics

D

Subbase & Manual Valves

H Series Micro

Moduflex Series

H Series ISO

Fieldbus Systems

DX ISOMAX Series

Valvair II Series

Non Plug-in, HB & HA Common Port Regulation

Provides adjustable regulated air pressure to the valve's #1 port which gives the same pressure to both the #2 and #4 port of the manifold or subbase. The regulator is always on the 14 end of the valve.

HB Common Port Regulator Shown - Single Solenoid, 14 Energized

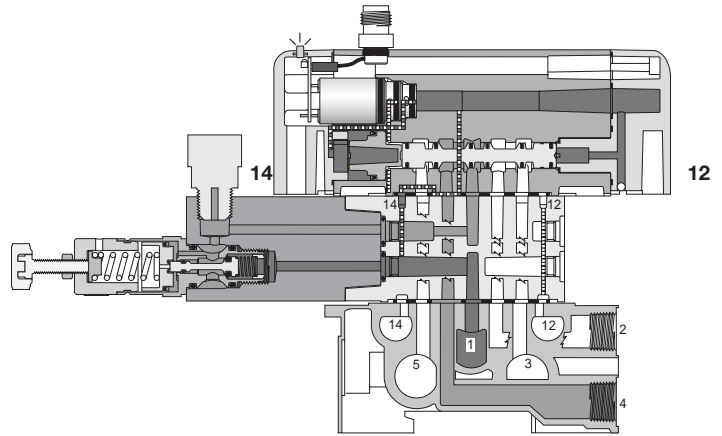
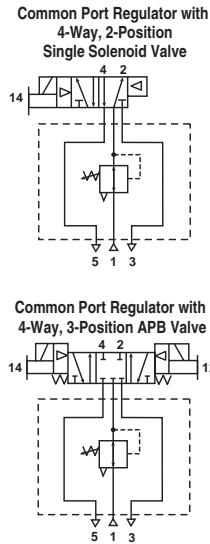

HB & HA Independent Dual Port Regulation

Dual Port Regulator

Provides regulated pressure to both ports. Pressure regulation can occur out of the #2 or #4 port of the valve.

HB Independent Dual Port Regulator Shown - Double Solenoid, 14 Energized

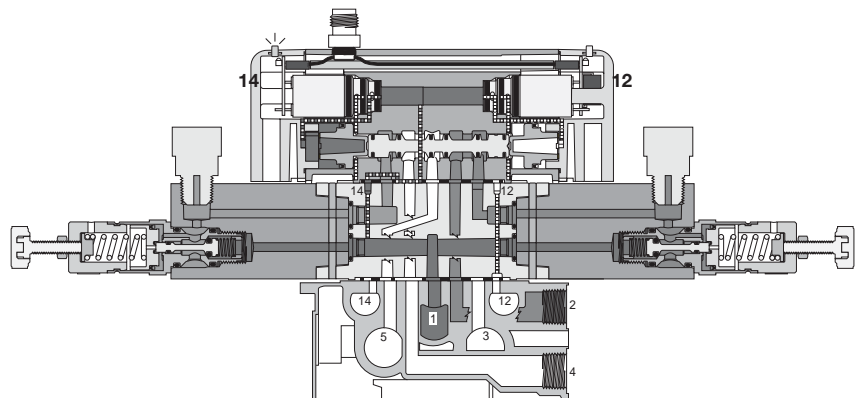
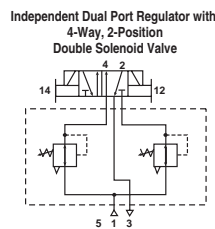

When using an Independent Pressure Sandwich Regulator, the cylinder outlet ports are reversed. The 12 end energizes the #4 port and the 14 end energizes the #2 port. The 3-Position CE and PC functions are also reversed. (See schematics on above.)

D	Subbase & Manual Valves
	H Series Micro
	Modulflex Series
	H Series ISO
	Fieldbus Systems
	DX ISOMAX Series
	Valvair II Series



For inventory, lead times, and kit lookup, visit www.pdnplu.com

Non Plug-in, 15407-1 Transition Plate Kits

PS562401 **0** **P**

Transition Plate Type*	
HA / HB to H2	PS562401

* Includes Left Hand and Right Hand End Plates.
 Use with PS5511 and PS5611 Manifolds Only.

Thread Type	
0	NPT
1*	BSPP "G"

* BSPP Conforms to ISO 1179-1 w 228-1
 Threads.

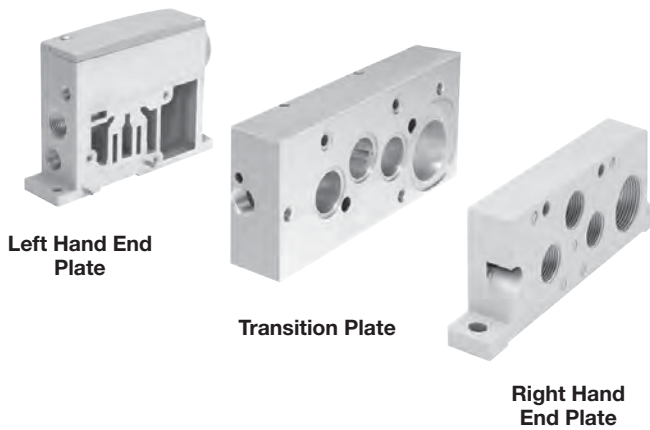

D

Subbase & Manual Valves

H Series Micro

Moduflex Series

H Series ISO

Fieldbus Systems

DX ISOMAX Series

Valvair II Series







For inventory, lead time, and kit lookup, visit www.pdnplu.com

D107

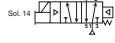
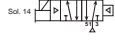
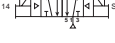
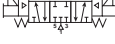
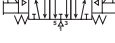
Parker Hannifin Corporation
 Pneumatic Division
 Richland, Michigan
www.parker.com/pneumatics

5599-1, Non Plug-in, Size 1 (H1) with Central Connectors

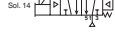
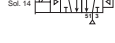
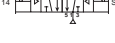
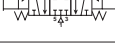
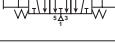
Symbol	Type	Cv	Operator	Voltage	Enclosure	Pilot	Non-locking	Locking
	4-way, 2-position, spring return	1.5	Single solenoid	24 VDC	4-pin, central M12 connector	Internal	H1EWXBG2B9000FD	H1EWXBH2B9000FD
						External	H1EWXXG2B9000FD	H1EWXXH2B9000FD
	4-way, 2-position, air return	1.5	Single solenoid	24 VDC	4-pin, central M12 connector	Internal	H11WXBG2B9000FD	H11WXBH2B9000FD
						External	H11WXXG2B9000FD	H11WXXH2B9000FD
	4-way, 2-position	1.5	Double solenoid	24 VDC	4-pin, central M12 connector	Internal	H12WXBG2B9000FD	H12WXBH2B9000FD
						External	H12WXXG2B9000FD	H12WXXH2B9000FD
	4-way, 3-position, all ports blocked	1.2	Double solenoid	24 VDC	4-pin, central M12 connector	Internal	H15WXBG2B9000FD	H15WXBH2B9000FD
						External	H15WXXG2B9000FD	H15WXXH2B9000FD
	4-way, 3-position, center exhaust	1.2	Double solenoid	24 VDC	4-pin, central M12 connector	Internal	H16WXBG2B9000FD	H16WXBH2B9000FD
						External	H16WXXG2B9000FD	H16WXXH2B9000FD
	4-way, 3-position, pressure center	1.2	Double solenoid	24 VDC	4-pin, central M12 connector	Internal	H17WXBG2B9000FD	H17WXBH2B9000FD
						External	H17WXXG2B9000FD	H17WXXH2B9000FD

Symbol	Type	Cv	Operator	Voltage	Enclosure	Pilot	Non-locking	Locking
	4-way, 2-position, spring return	1.5	Single solenoid	120 VAC	5-Pin, central 7/8" mini connector	Internal	H1EWXBG323000FD	H1EWXBH323000FD
						External	H1EWXXG323000FD	H1EWXXH323000FD
	4-way, 2-position, air return	1.5	Single solenoid	120 VAC	5-Pin, central 7/8" mini connector	Internal	H11WXBG323000FD	H11WXBH323000FD
						External	H11WXXG323000FD	H11WXXH323000FD
	4-way, 2-position	1.5	Double solenoid	120 VAC	5-Pin, central 7/8" mini connector	Internal	H12WXBG323000FD	H12WXBH323000FD
						External	H12WXXG323000FD	H12WXXH323000FD
	4-way, 3-position, all ports blocked	1.2	Double solenoid	120 VAC	5-Pin, central 7/8" mini connector	Internal	H15WXBG323000FD	H15WXBH323000FD
						External	H15WXXG323000FD	H15WXXH323000FD
	4-way, 3-position, center exhaust	1.2	Double solenoid	120 VAC	5-Pin, central 7/8" mini connector	Internal	H16WXBG323000FD	H16WXBH323000FD
						External	H16WXXG323000FD	H16WXXH323000FD
	4-way, 3-position, pressure center	1.2	Double solenoid	120 VAC	5-Pin, central 7/8" mini connector	Internal	H17WXBG323000FD	H17WXBH323000FD
						External	H17WXXG323000FD	H17WXXH323000FD

D
Subbase & Manual Valves
H Series Micro
Moduteflex Series
H Series ISO
Fieldbus Systems
DX ISOMAX Series
Valvair II Series

 Most popular.









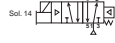
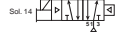
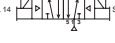

For inventory, lead times, and kit lookup, visit www.pdnplu.com

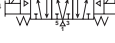
D108

Parker Hannifin Corporation
 Pneumatic Division
 Richland, Michigan
www.parker.com/pneumatics

5599-1, Non Plug-in, Size 1 (H1) with 3-Pin DIN Connectors

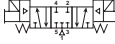
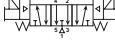
Symbol	Type	Cv	Operator	Voltage	Enclosure	Pilot	Non-locking	Locking
	4-way, 2-position, spring return	1.5	Single solenoid	24 VDC	3-pin DIN connector on coil	Internal	H1EWXBBL49D	H1EWXBBDL49D
						External	H1EWXXBL49D	H1EWXXDL49D
	4-way, 2-position, air return	1.5	Single solenoid	24 VDC	3-pin DIN connector on coil	Internal	H11WXBBL49D	H11WXBBDL49D
						External	H11WXXBL49D	H11WXXDL49D
	4-way, 2-position	1.5	Double solenoid	24 VDC	3-pin DIN connector on coil	Internal	H12WXBBL49D	H12WXBBDL49D
						External	H12WXXBL49D	H12WXXDL49D
	4-way, 3-position, all ports blocked	1.2	Double solenoid	24 VDC	3-pin DIN connector on coil	Internal	H15WXBBL49D	H15WXBBDL49D
						External	H15WXXBL49D	H15WXXDL49D
	4-way, 3-position, center exhaust	1.2	Double solenoid	24 VDC	3-pin DIN connector on coil	Internal	H16WXBBL49D	H16WXBBDL49D
						External	H16WXXBL49D	H16WXXDL49D
	4-way, 3-position, pressure center	1.2	Double solenoid	24 VDC	3-pin DIN connector on coil	Internal	H17WXBBL49D	H17WXBBDL49D
						External	H17WXXBL49D	H17WXXDL49D

Symbol	Type	Cv	Operator	Voltage	Enclosure	Pilot	Non-locking	Locking
	4-way, 2-position, spring return	1.5	Single solenoid	120 VAC	3-pin DIN connector on coil	Internal	H1EWXBBL53D	H1EWXBBDL53D
						External	H1EWXXBL53D	H1EWXXDL53D
	4-way, 2-position, air return	1.5	Single solenoid	120 VAC	3-pin DIN connector on coil	Internal	H11WXBBL53D	H11WXBBDL53D
						External	H11WXXBL53D	H11WXXDL53D
	4-way, 2-position	1.5	Double solenoid	120 VAC	3-pin DIN connector on coil	Internal	H12WXBBL53D	H12WXBBDL53D
						External	H12WXXBL53D	H12WXXDL53D
	4-way, 3-position, all ports blocked	1.2	Double solenoid	120 VAC	3-pin DIN connector on coil	Internal	H15WXBBL53D	H15WXBBDL53D
						External	H15WXXBL53D	H15WXXDL53D
	4-way, 3-position, center exhaust	1.2	Double solenoid	120 VAC	3-pin DIN connector on coil	Internal	H16WXBBL53D	H16WXBBDL53D
						External	H16WXXBL53D	H16WXXDL53D
	4-way, 3-position, pressure center	1.2	Double solenoid	120 VAC	3-pin DIN connector on coil	Internal	H17WXBBL53D	H17WXBBDL53D
						External	H17WXXBL53D	H17WXXDL53D

5599-1, Non Plug-in, Size 1 (H1)

	Single subbase	Description	3/8" NPT	3/8" BSPP
		Side ported base	PS4011150DP	PS4011160DP
	Manifold bases	Description	3/8" NPT	3/8" BSPP
		End ported bases	PS4011550DP	PS4011560CP
		Bottom / end ported bases	PS4011650CP	PS4011660CP
	End plate kits	Description	NPT port	BSPP port
		H1 Non-collective wiring end plates	PS4031010CP	PS4031011DP

 Most popular.



For inventory, lead time, and kit lookup, visit www.pdnplu.com

D109

Parker Hannifin Corporation
Pneumatic Division
Richland, Michigan
www.parker.com/pneumatics

D

Subbase & Manual Valves

H Series Micro

Modulflex Series







H Series ISO

Fieldbus Systems

DX ISOMAX Series

Valvair II Series

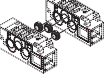
5599-1, Non Plug-in, Size 1 (H1) Accessories

Accessory	Description	Part number
 Sandwich regulator	Common pressure 5-125 PSIG w/ gauge	PS4037166CP
	Independent pressure 5-125 PSIG w/ gauge	PS4037266CP
 Blanking plate kit		PS4034CP
 Sandwich flow control		PS4042CP
Sandwich Flow Control and Common Port Sandwich Regulator may be sandwiched together on a manifold or subbase. The Sandwich Flow Control MUST be located between the manifold/subbase and the Common Port Sandwich Regulator.		
 Manifold to manifold gasket kits		PS4013P
 Manifold port isolation kit	Main galley (1, 3, 5)	PS4032CP
	Pilot galley	PS4033CP
 Auxiliary access plate kit	1/4" & 3/8"	PS403000CP
		NPT BSPP

D

Subbase & Manual Valves

H Series Micro

Modutflex Series

H Series ISO

Fieldbus Systems

DX ISOMAX Series

Valvair II Series

 Most popular.



For inventory, lead times, and kit lookup, visit www.pdnplu.com

D110

Parker Hannifin Corporation
 Pneumatic Division
 Richland, Michigan
www.parker.com/pneumatics

How To Order Non Plug-in Add-A-Fold Assemblies

1. List Add-A-Fold Assembly call out. This automatically includes the end plate kit assembly.
2. List complete Valve, Regulator, Flow Control and Base model number. List left to right, LOOKING AT THE CYLINDER PORTS on the #12 end of the manifold. The left most station is station 1. (If a blank station is needed, list the blanking plate part number and the individual manifold number in the station specified.)

Example

Application requires a 3-Station manifold with a valve, regulator on Station 3.

Item	Qty.	Part No.	Location
01	1	AAH1S003	
02	1	H11WXBG2B9000FD	Station 1
03	1	PS4011550CP	Station 1
04	1	H12WXBG2B9000FD	Station 2
05	1	PS4011550CP	Station 2
06	1	H12WXXG2B9000FD	Station 3
07	1	PS4037166CP	Station 3
08	1	PS4011550CP	Station 3

NOTE: Construct manifold assemblies from left to right while looking at the cylinder ports.

Valves must be ordered as External Pilot when using Sandwich Regulator.

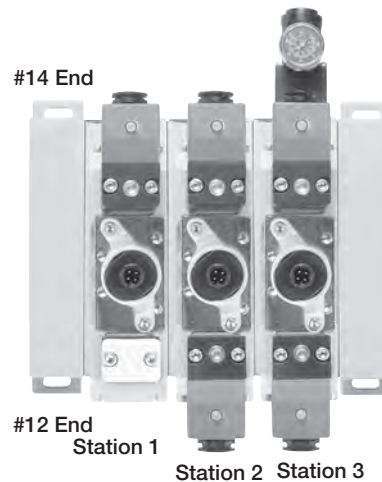

Example:
 3-Station Manifold with (3) H1 Valves
 on Manifold Bases
 and Regulator at Station 3

Add-A-Fold Assembly Model Number

AA	H1	S	0	03	
Valve series		End plate type		Transition plate	
Right & left end plate H1		Standard - non-collective wiring S		Blank No transition plate	
				C H1 to H2	
				D H1 to H3	
				Number of stations	
				01	
				02	
				03	
				04	
				•	
				•	
				24	



* BSPP Conforms to ISO 1179-1 w 228-1 Threads.

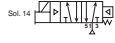
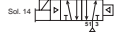
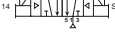
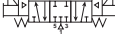
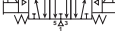
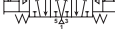

For inventory, lead time, and kit lookup, visit www.pdnplu.com

5599-1, Non Plug-in, Size 2 (H2) with Central Connectors

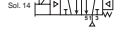
Symbol	Type	Cv	Operator	Voltage	Enclosure	Pilot	Non-locking	Locking
	4-way, 2-position, spring return	3.0	Single solenoid	24 VDC	4-pin, central M12 connector	Internal	H2EWXBG2B9000FD	H2EWXBH2B9000FD
						External	H2EWXXG2B9000FD	H2EWXXH2B9000FD
	4-way, 2-position, air return	3.0	Single solenoid	24 VDC	4-pin, central M12 connector	Internal	H21WXBG2B9000FD	H21WXBH2B9000FD
						External	H21WXXG2B9000FD	H21WXXH2B9000FD
	4-way, 2-position	3.0	Double solenoid	24 VDC	4-pin, central M12 connector	Internal	H22WXBG2B9000FD	H22WXBH2B9000FD
						External	H22WXXG2B9000FD	H22WXXH2B9000FD
	4-way, 3-position, all ports blocked	2.8	Double solenoid	24 VDC	4-pin, central M12 connector	Internal	H25WXBG2B9000FD	H25WXBH2B9000FD
						External	H25WXXG2B9000FD	H25WXXH2B9000FD
	4-way, 3-position, center exhaust	2.8	Double solenoid	24 VDC	4-pin, central M12 connector	Internal	H26WXBG2B9000FD	H26WXBH2B9000FD
						External	H26WXXG2B9000FD	H26WXXH2B9000FD
	4-way, 3-position, pressure center	2.8	Double solenoid	24 VDC	4-pin, central M12 connector	Internal	H27WXBG2B9000FD	H27WXBH2B9000FD
						External	H27WXXG2B9000FD	H27WXXH2B9000FD

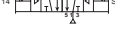
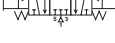
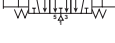
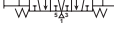
Symbol	Type	Cv	Operator	Voltage	Enclosure	Pilot	Non-locking	Locking
	4-way, 2-position, spring return	3.0	Single solenoid	120 VAC	5-Pin, central 7/8" mini connector	Internal	H2EWXBG323000FD	H2EWXBH323000FD
						External	H2EWXXG323000FD	H2EWXXH323000FD
	4-way, 2-position, air return	3.0	Single solenoid	120 VAC	5-Pin, central 7/8" mini connector	Internal	H21WXBG323000FD	H21WXBH323000FD
						External	H21WXXG323000FD	H21WXXH323000FD
	4-way, 2-position	3.0	Double solenoid	120 VAC	5-Pin, central 7/8" mini connector	Internal	H22WXBG323000FD	H22WXBH323000FD
						External	H22WXXG323000FD	H22WXXH323000FD
	4-way, 3-position, all ports blocked	2.8	Double solenoid	120 VAC	5-Pin, central 7/8" mini connector	Internal	H25WXBG323000FD	H25WXBH323000FD
						External	H25WXXG323000FD	H25WXXH323000FD
	4-way, 3-position, center exhaust	2.8	Double solenoid	120 VAC	5-Pin, central 7/8" mini connector	Internal	H26WXBG323000FD	H26WXBH323000FD
						External	H26WXXG323000FD	H26WXXH323000FD
	4-way, 3-position, pressure center	2.8	Double solenoid	120 VAC	5-Pin, central 7/8" mini connector	Internal	H27WXBG323000FD	H27WXBH323000FD
						External	H27WXXG323000FD	H27WXXH323000FD

5599-1, Non Plug-in, Size 2 (H2) with 3-Pin DIN Connectors

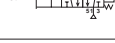
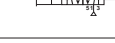
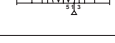
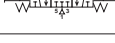
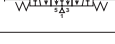
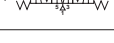
Symbol	Type	Cv	Operator	Voltage	Enclosure	Pilot	Non-locking	Locking
	4-way, 2-position, spring return	3.0	Single solenoid	24 VDC	3-pin DIN connector on coil	Internal	H2EWXBBL49D	H2EWXBCL49D
						External	H2EWXXBL49D	H2EWXXCL49D
	4-way, 2-position, air return	3.0	Single solenoid	24 VDC	3-pin DIN connector on coil	Internal	H21WXBBL49D	H21WXBCL49D
						External	H21WXXBL49D	H21WXXCL49D
	4-way, 2-position	3.0	Double solenoid	24 VDC	3-pin DIN connector on coil	Internal	H22WXBBL49D	H22WXBCL49D
						External	H22WXXBL49D	H22WXXCL49D
	4-way, 3-position, all ports blocked	2.8	Double solenoid	24 VDC	3-pin DIN connector on coil	Internal	H25WXBBL49D	H25WXBCL49D
						External	H25WXXBL49D	H25WXXCL49D
	4-way, 3-position, center exhaust	2.8	Double solenoid	24 VDC	3-pin DIN connector on coil	Internal	H26WXBBL49D	H26WXBCL49D
						External	H26WXXBL49D	H26WXXCL49D
	4-way, 3-position, pressure center	2.8	Double solenoid	24 VDC	3-pin DIN connector on coil	Internal	H27WXBBL49D	H27WXBCL49D
						External	H27WXXBL49D	H27WXXCL49D



 Most popular.

D
 Subbase & Manual Valves
 H Series Micro
 Modutrex Series
 H Series ISO
 Fieldbus Systems
 DX ISOMAX Series
 Valvair II Series



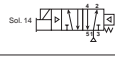
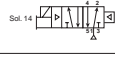
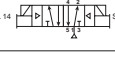
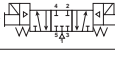
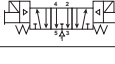

For inventory, lead times, and kit lookup, visit www.pdnplu.com





5599-1, Non Plug-in, Size 2 (H2) with 3-Pin DIN Connectors

Symbol	Type	Cv	Operator	Voltage	Enclosure	Pilot	Non-locking	Locking
	4-way, 2-position, spring return	3.0	Single solenoid	120 VAC	3-pin DIN connector on coil	Internal	H2EWXBBL53D	H2EWXBCL53D
						External	H2EWXXBBL53D	H2EWXXCL53D
	4-way, 2-position, air return	3.0	Single solenoid	120 VAC	3-pin DIN connector on coil	Internal	H21WXBBL53D	H21WXBCL53D
						External	H21WXXBBL53D	H21WXXCL53D
	4-way, 2-position	3.0	Double solenoid	120 VAC	3-pin DIN connector on coil	Internal	H22WXBBL53D	H22WXBCL53D
						External	H22WXXBBL53D	H22WXXCL53D
	4-way, 3-position, all ports blocked	2.8	Double solenoid	120 VAC	3-pin DIN connector on coil	Internal	H25WXBBL53D	H25WXBCL53D
						External	H25WXXBBL53D	H25WXXCL53D
	4-way, 3-position, center exhaust	2.8	Double solenoid	120 VAC	3-pin DIN connector on coil	Internal	H26WXBBL53D	H26WXBCL53D
						External	H26WXXBBL53D	H26WXXCL53D
	4-way, 3-position, pressure center	2.8	Double solenoid	120 VAC	3-pin DIN connector on coil	Internal	H27WXBBL53D	H27WXBCL53D
						External	H27WXXBBL53D	H27WXXCL53D

5599-1, Non Plug-in, Size 2 (H2)

Single subbase	Description	1/2" NPT	1/2" BSPP
	Side ported base	PS4111170CP	PS4111180CP
Manifold bases	Description	1/2" NPT	1/2" BSPP
	End ported bases	PS4111570CP	PS4111580CP
	Bottom / end ported bases	PS4111670CP	PS4111680CP
	Note: Manifolds include 2 pipe plugs		
End plate kits	Description	NPT port	BSPP port
	H2 Non-collective wiring end plates	PS4131010DP	PS4131011DP

5599-1, Non Plug-in, Size 2 (H2) Accessories

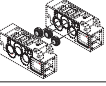
Accessory	Description	Part number
	Common pressure 5-125 PSIG w/ gauge	PS4137166CP
	Independent pressure 5-125 PSIG w/ gauge	PS4137266CP
	Blanking plate kit	PS4134CP
	Sandwich flow control	PS4142CP
	Sandwich Flow Control and Common Port Sandwich Regulator may be sandwiched together on a manifold or subbase. The Sandwich Flow Control MUST be located between the manifold/subbase and the Common Port Sandwich Regulator.	
	Manifold to manifold gasket kits	PS4113P
	Main galley (1, 3, 5)	PS4132CP
	Pilot galley	PS4033CP

 Most popular.



For inventory, lead time, and kit lookup, visit www.pdnplu.com

D113

Parker Hannifin Corporation
Pneumatic Division
Richland, Michigan
www.parker.com/pneumatics

D

Subbase & Manual Valves

H Series Micro

Modulflex Series

H Series ISO

Fieldbus Systems

DX ISOMAX Series

Valvair II Series

How To Order Non Plug-in Add-A-Fold Assemblies

1. List Add-A-Fold Assembly call out. This automatically includes the end plate kit assembly.
2. List complete Valve, Regulator, Flow Control and Base model number. List left to right, LOOKING AT THE CYLINDER PORTS on the #12 end of the manifold. The left most station is station 1. (If a blanking plate part number and the individual manifold number in the station specified.)

Example

Application requires a 3-Station manifold with a valve and regulator on Station 3.

Item	Qty.	Part No.	Location
01	1	AAH2S003	
02	1	H21WXBG2B9000FD	Station 1
03	1	PS4111570CP	Station 1
04	1	H22WXBG2B9000FD	Station 2
05	1	PS4111570CP	Station 2
06	1	H22WXXG2B9000FD	Station 3
07	1	PS4137166CP	Station 3
08	1	PS4111570CP	Station 3

NOTE: Construct manifold assemblies from left to right while looking at the cylinder ports.
 Valves must be ordered as External Pilot when using Sandwich Regulator.

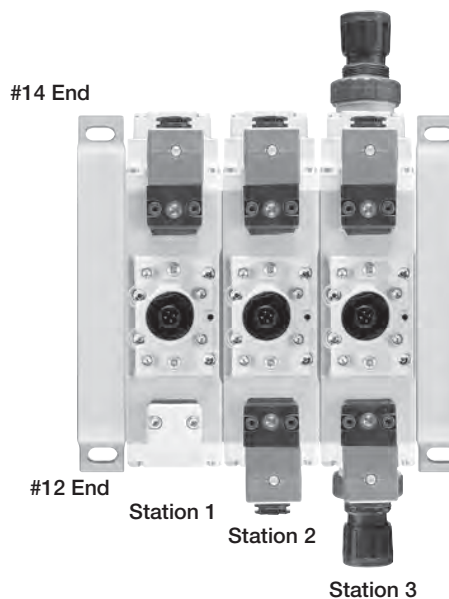

Example:
 3-Station Manifold with (3) H2 Valves on Manifold Bases and Regulator at Station 3

Add-A-Fold Assembly Model Number

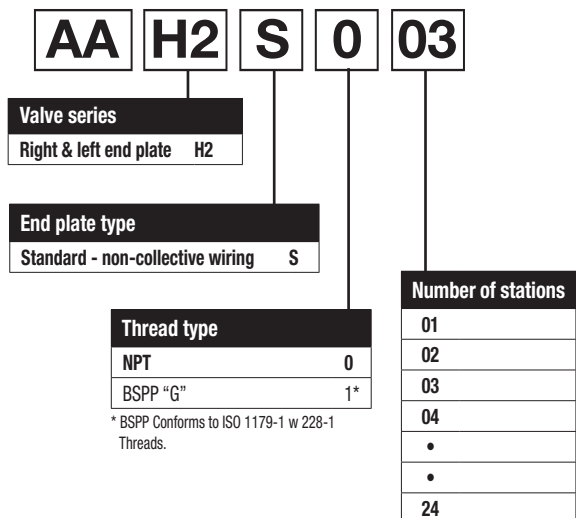



D	Subbase & Manual Valves
H Series Micro	Moduteflex Series
H Series ISO	
Fieldbus Systems	
DX ISOMAX Series	
Valvair II Series	

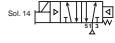
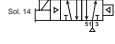
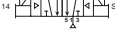
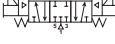
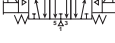
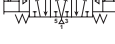

For inventory, lead times, and kit lookup, visit www.pdnplu.com

5599-1, Non Plug-in, Size 3 (H3) with Central Connectors

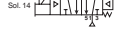
Symbol	Type	Cv	Operator	Voltage	Enclosure	Pilot	Non-locking	Locking
	4-way, 2-position, spring return	6.0	Single solenoid	24 VDC	4-pin, central M12 connector	Internal	H3EWXBG2B9000FD	H3EWXBH2B9000FD
						External	H3EWXG2B9000FD	H3EWXH2B9000FD
	4-way, 2-position, air return	6.0	Single solenoid	24 VDC	4-pin, central M12 connector	Internal	H31WXBG2B9000FD	H31WXBH2B9000FD
						External	H31WXXG2B9000FD	H31WXXH2B9000FD
	4-way, 2-position	6.0	Double solenoid	24 VDC	4-pin, central M12 connector	Internal	H32WXBG2B9000FD	H32WXBH2B9000FD
						External	H32WXXG2B9000FD	H32WXXH2B9000FD
	4-way, 3-position, all ports blocked	5.0	Double solenoid	24 VDC	4-pin, central M12 connector	Internal	H35WXBG2B9000FD	H35WXBH2B9000FD
						External	H35WXXG2B9000FD	H35WXXH2B9000FD
	4-way, 3-position, center exhaust	5.0	Double solenoid	24 VDC	4-pin, central M12 connector	Internal	H36WXBG2B9000FD	H36WXBH2B9000FD
						External	H36WXXG2B9000FD	H36WXXH2B9000FD
	4-way, 3-position, pressure center	5.0	Double solenoid	24 VDC	4-pin, central M12 connector	Internal	H37WXBG2B9000FD	H37WXBH2B9000FD
						External	H37WXXG2B9000FD	H37WXXH2B9000FD

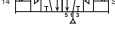
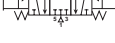
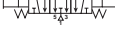
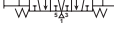
Symbol	Type	Cv	Operator	Voltage	Enclosure	Pilot	Non-locking	Locking
	4-way, 2-position, spring return	6.0	Single solenoid	120 VAC	5-Pin, central 7/8" mini connector	Internal	H3EWXBG323000FD	H3EWXBH323000FD
						External	H3EWXG323000FD	H3EWXH323000FD
	4-way, 2-position, air return	6.0	Single solenoid	120 VAC	5-Pin, central 7/8" mini connector	Internal	H31WXBG323000FD	H31WXBH323000FD
						External	H31WXXG323000FD	H31WXXH323000FD
	4-way, 2-position	6.0	Double solenoid	120 VAC	5-Pin, central 7/8" mini connector	Internal	H32WXBG323000FD	H32WXBH323000FD
						External	H32WXXG323000FD	H32WXXH323000FD
	4-way, 3-position, all ports blocked	5.0	Double solenoid	120 VAC	5-Pin, central 7/8" mini connector	Internal	H35WXBG323000FD	H35WXBH323000FD
						External	H35WXXG323000FD	H35WXXH323000FD
	4-way, 3-position, center exhaust	5.0	Double solenoid	120 VAC	5-Pin, central 7/8" mini connector	Internal	H36WXBG323000FD	H36WXBH323000FD
						External	H36WXXG323000FD	H36WXXH323000FD
	4-way, 3-position, pressure center	5.0	Double solenoid	120 VAC	5-Pin, central 7/8" mini connector	Internal	H37WXBG323000FD	H37WXBH323000FD
						External	H37WXXG323000FD	H37WXXH323000FD

5599-1, Non Plug-in, Size 3 (H3) with 3-Pin DIN Connectors

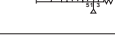
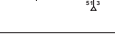
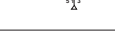
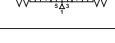
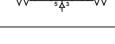
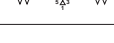
Symbol	Type	Cv	Operator	Voltage	Enclosure	Pilot	Non-locking	Locking
	4-way, 2-position, spring return	6.0	Single solenoid	24 VDC	3-pin DIN connector on coil	Internal	H3EWXBBL49D	H3EWXBCL49D
						External	H3EWXBL49D	H3EWXCL49D
	4-way, 2-position, air return	6.0	Single solenoid	24 VDC	3-pin DIN connector on coil	Internal	H31WXBBL49D	H31WXBCL49D
						External	H31WXXBL49D	H31WXXCL49D
	4-way, 2-position	6.0	Double solenoid	24 VDC	3-pin DIN connector on coil	Internal	H32WXBBL49D	H32WXBCL49D
						External	H32WXXBL49D	H32WXXCL49D
	4-way, 3-position, all ports blocked	5.0	Double solenoid	24 VDC	3-pin DIN connector on coil	Internal	H35WXBBL49D	H35WXBCL49D
						External	H35WXXBL49D	H35WXXCL49D
	4-way, 3-position, center exhaust	5.0	Double solenoid	24 VDC	3-pin DIN connector on coil	Internal	H36WXBBL49D	H36WXBCL49D
						External	H36WXXBL49D	H36WXXCL49D
	4-way, 3-position, pressure center	5.0	Double solenoid	24 VDC	3-pin DIN connector on coil	Internal	H37WXBBL49D	H37WXBCL49D
						External	H37WXXBL49D	H37WXXCL49D

 Most popular.



For inventory, lead time, and kit lookup, visit www.pdnplu.com

D115

Parker Hannifin Corporation
Pneumatic Division
Richland, Michigan
www.parker.com/pneumatics

D

Subbase & Manual Valves

H Series Micro

Modulflex Series





H Series ISO

Fieldbus Systems

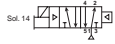
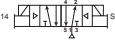

DX ISOMAX Series

Valvair II Series





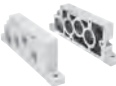

5599-1, Non Plug-in, Size 3 (H3) with 3-Pin DIN Connectors

Symbol	Type	Cv	Operator	Voltage		Pilot	Non-locking	Locking
	4-way, 2-position, spring return	6.0	Single solenoid	120 VAC	3-pin DIN connector on coil	Internal	H3EWXBBL53D	H3EWXBCL53D
						External	H3EWXXBL53D	H3EWXXCL53D
	4-way, 2-position, air return	6.0	Single solenoid	120 VAC	3-pin DIN connector on coil	Internal	H31WXBBL53D	H31WXBCL53D
						External	H31WXXBL53D	H31WXXCL53D
	4-way, 2-position	6.0	Double solenoid	120 VAC	3-pin DIN connector on coil	Internal	H32WXBBL53D	H32WXBCL53D
						External	H32WXXBL53D	H32WXXCL53D
	4-way, 3-position, all ports blocked	5.0	Double solenoid	120 VAC	3-pin DIN connector on coil	Internal	H35WXBBL53D	H35WXBCL53D
						External	H35WXXBL53D	H35WXXCL53D
	4-way, 3-position, center exhaust	5.0	Double solenoid	120 VAC	3-pin DIN connector on coil	Internal	H36WXBBL53D	H36WXBCL53D
						External	H36WXXBL53D	H36WXXCL53D
	4-way, 3-position, pressure center	5.0	Double solenoid	120 VAC	3-pin DIN connector on coil	Internal	H37WXBBL53D	H37WXBCL53D
						External	H37WXXBL53D	H37WXXCL53D

5599-1, Non Plug-in, Size 3 (H3)

Single subbase	Description	3/4" NPT	3/4" BSPP
	Side ported base	PS4211190CP	PS4211180CP
Manifold bases	Description	3/4" NPT	3/4" BSPP
	End ported bases	PS4211590CP	PS4211500CP
	Bottom / end ported bases	PS4211690CP	PS4211600CP
	Note: Manifolds include 2 pipe plugs		
End plate kits	Description	NPT port	BSPP port
	H3 Non-collective wiring end plates	PS4231010DP	PS4231011DP

5599-1, Non Plug-in, Size 3 (H3) Accessories

Accessory	Description	Part number
	Common pressure 5-125 PSIG w/ gauge	PS4237166CP
	Independent pressure 5-125 PSIG w/ gauge	PS4237266CP
	Blanking plate kit	PS4234CP
	Sandwich flow control	PS4242CP
	Sandwich Flow Control and Common Port Sandwich Regulator may be sandwiched together on a manifold or subbase. The Sandwich Flow Control MUST be located between the manifold/subbase and the Common Port Sandwich Regulator.	
	Manifold to manifold gasket kits	PS4213P
	Main galley (1, 3, 5)	PS4232CP
	Pilot galley	PS4033CP

 Most popular.

D
 Subbase & Manual Valves
 H Series Micro
 Moduteflex Series
 H Series ISO
 Fieldbus Systems
 DX ISOMAX Series
 Valvair II Series



For inventory, lead times, and kit lookup, visit www.pdnplu.com

D116

Parker Hannifin Corporation
 Pneumatic Division
 Richland, Michigan
www.parker.com/pneumatics

How To Order Non Plug-in Add-A-Fold Assemblies

1. List Add-A-Fold Assembly call out. This automatically includes the end plate kit assembly.
2. List complete Valve, Regulator, Flow Control and Base model number. List left to right, LOOKING AT THE CYLINDER PORTS on the #12 end of the manifold. The left most station is station 1. (If a blank station is needed, list the blanking plate part number and the individual manifold number in the station specified.)

Example

Application requires a 3-Station manifold with a valve and regulator on Station 3.

Item	Qty.	Part No.	Location
01	1	AAH3S003	
02	1	H31WXBG2B9000FD	Station 1
03	1	PS4211590CP	Station 1
04	1	H32WXBG2B9000FD	Station 2
05	1	PS4211590CP	Station 2
06	1	H32WXXG2B9000FD	Station 3
07	1	PS4237166CP	Station 3
08	1	PS4211590CP	Station 3

NOTE: Construct manifold assemblies from left to right while looking at the cylinder ports.
 Valves must be ordered as External Pilot when using Sandwich Regulator.

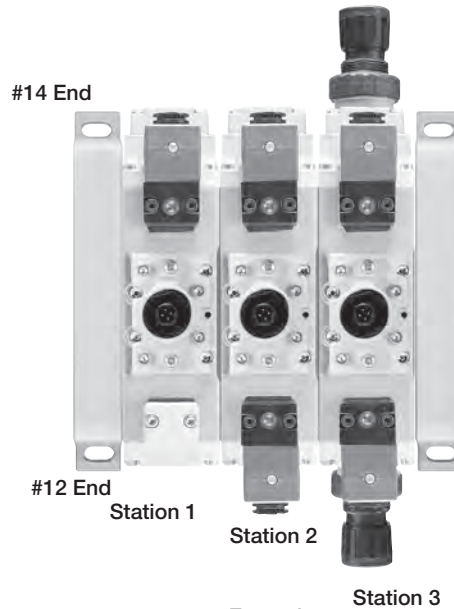

Example:
 3-Station Manifold with (3) H3 Valves
 on Manifold Bases and Regulator at Station 3

Add-A-Fold Assembly Model Number

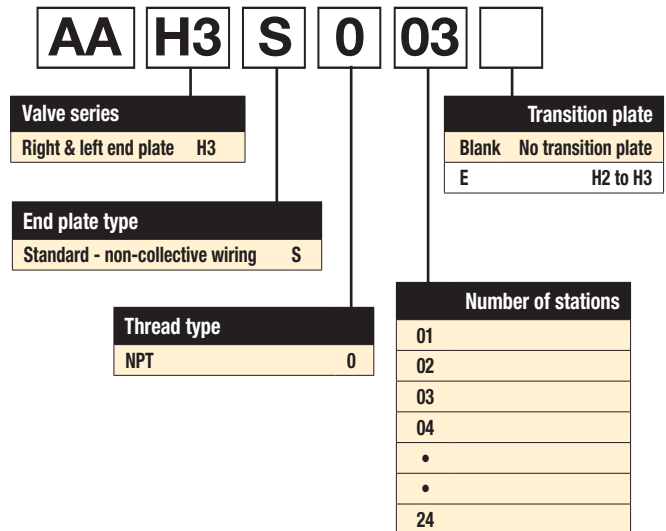

5599-1 Non Plug-in Transition Plate Kits

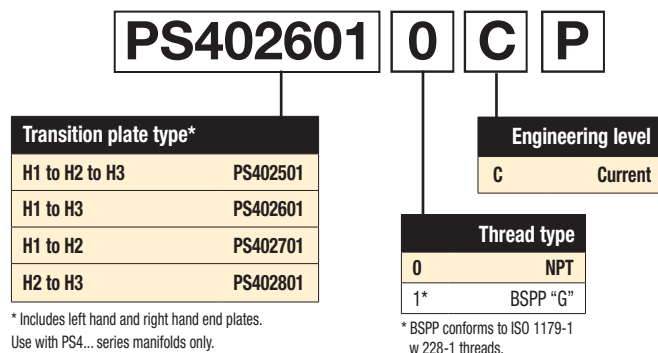

* Includes left hand and right hand end plates.
 Use with PS4... series manifolds only.

* BSPP conforms to ISO 1179-1
 w 228-1 threads.



Most popular.



For inventory, lead time, and kit lookup, visit www.pdnplu.com

D117

Parker Hannifin Corporation
 Pneumatic Division
 Richland, Michigan
www.parker.com/pneumatics

D

Subbase & Manual Valves

H Series Micro

Moduflex Series

H Series ISO

Fieldbus Systems

DX ISOMAX Series

Valvair II Series

Non Plug-in, 5599-1, Central Connector - Size 1, 2, & 3

H1 E WX B G 2B9 000F D

Basic series 5599-1	
ISO 5599-1 Size 1	H1
ISO 5599-1 Size 2	H2
ISO 5599-1 Size 3	H3

5599 -1 Engineering level	
D	Current

5599-1 Operator / Function	
Single solenoid, 2-position - air return	1
Double solenoid, 2-position	2
Double solenoid, 3-position - APB	5
Double solenoid, 3-position - CE	6
Double solenoid, 3-position - PC	7
Single solenoid, 2-position - air return, spring assist	E

5599-1 Central connector wiring options	
000C	Chrysler
000F*	SAE / Ford, ISO 20401
000G	General Motors

* Complies to ISO 20401 with Enclosure Lead Length "2".

5599-1 Mounting	
Valve less base	WX

5599-1 Pilot source / Pilot exhaust	
Internal pilot, port #1 / vented	B
External pilot, port #12 or #14 / vented	X*

* Must be specified when using Sandwich Regulators.

5599-1 Overrides / Lights	
Non-locking, flush, with light	G
Locking, flush, with light	H

Enclosure / Lead length / Voltage*				
	AC		DC	
	60Hz	50Hz		
1B9 [†]			24	3-pin, central mini connector
123 [†]	120	115		3-pin, central mini connector
2B9			24	4-pin, central M12 connector
3B9			24	5-pin, central mini connector
323	120	115		5-pin, central mini connector
619 [†]			24	2-pin, M12 connector on coil

* All coils include LED & suppression

[†] Operator function "1" or "E"

* Only available with wiring option "000F"

D
 Subbase & Manual Valves
 H Series Micro
 Modutefx Series
 H Series ISO
 Fieldbus Systems
 DX ISOMAX Series
 Valvair II Series

Non Plug-in, 5599-1, CNOMO - Size 1, 2, & 3

H1 E WX B B L53 D

Basic series 5599-1	
ISO 5599-1 Size 1	H1
ISO 5599-1 Size 2	H2
ISO 5599-1 Size 3	H3

5599-1 Engineering level	
D	Current

5599-1 Operator / Function	
Single solenoid, 2-position - air return	1
Double solenoid, 2-position	2
Double solenoid, 3-position - APB	5
Double solenoid, 3-position - CE	6
Double solenoid, 3-position - PC	7
Single solenoid, 2-position - air return, spring assist	E

Enclosure / Lead length / Voltage				
	AC		DC	
	60Hz	50Hz		
L42	24			3-pin, 30mm DIN 43650A with CNOMO connector
L45			12	3-pin, 30mm DIN 43650A with CNOMO connector
L49			24	3-pin, 30mm DIN 43650A with CNOMO connector
L53	120	115		3-pin, 30mm DIN 43650A with CNOMO connector
L57	240			3-pin, 30mm DIN 43650A with CNOMO connector
NXX				Valve less coil

5599-1 Mounting	
Valve less base	WX

5599-1 Pilot source / Pilot exhaust	
Internal pilot, port #1 / vented	B
External pilot, port #12 or #14 / vented	X*

* Must be specified when using Sandwich Regulators.

5599-1 Overrides / Lights	
B	Non-locking, flush, push - no light
C	Locking, flush, push / turn - no light

Most popular.



For inventory, lead times, and kit lookup, visit www.pdnplu.com

D118

Parker Hannifin Corporation
 Pneumatic Division
 Richland, Michigan
www.parker.com/pneumatics

Non Plug-in, 5599-1, Size 1, 2, & 3 Manifold / Subbase Kits

PS401155 0 D P

Engineering Level	
C	For H2 & H3
D	For H1

Enclosures / Lead Length	
0	None, No Electrical Plug - 5599-1

Mounting Base Style / Port Size		H1 Series		H2 Series		H3 Series	
Subbase: 3/8 NPT Side Ports	PS401115	Subbase: 1/2 NPT Side Ports	PS411117	Subbase: 3/4 NPT Side Ports	PS421119		
Subbase: 3/8 BSPP Side Ports	PS401116	Subbase: 1/2 BSPP Side Ports	PS411118*	Subbase: 3/4 BSPP Side Port	PS421110*		
Manifold: 3/8 NPT End Ports	PS401155	Manifold: 1/2 NPT End Port	PS411157	Manifold: 3/4 NPT End Port	PS421159		
Manifold: 3/8 BSPP End Ports	PS401156*	Manifold: 1/2 BSPP End Ports	PS411158*	Manifold: 3/4 BSPP End Port	PS421150*		
Manifold: 3/8 NPT Bottom / End Port	PS401165†	Manifold: 1/2 NPT Bottom / End Port	PS411167	Manifold: 3/4 NPT Bottom / End Port	PS421169		
Manifold: 3/8 BSPP Bottom / End Port	PS401166*†	Manifold: 1/2 BSPP Bottom / End Port	PS411168*	Manifold: 3/4 BSPP Bottom / End Port	PS421160*		

* BSPP Conforms to ISO 1179-1 w 228-1 Threads.

† #1 Bottom Port - 1/4".

Subbase Kits

Manifold Kits

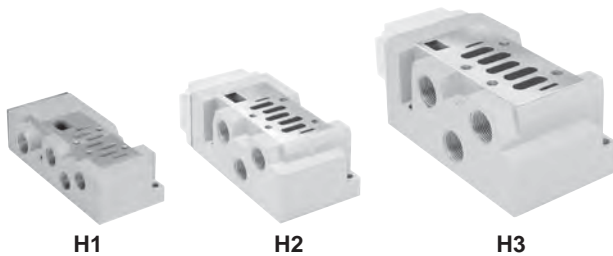

Non-Plug-in, 5599-1, End Plate Kits

PS403101 0 C P

Basic Series	
ISO 5599, Size 1	PS403101
ISO 5599, Size 2	PS413101
ISO 5599, Size 3	PS423101

Thread Type	
0	NPT
1*	BSPP "G"

* BSPP Conforms to ISO 1179-1 w 228-1 Threads.



H1 Non-Collective Wiring End Plates



For inventory, lead time, and kit lookup, visit www.pdnplu.com

D119

Parker Hannifin Corporation
 Pneumatic Division
 Richland, Michigan
www.parker.com/pneumatics

D

Subbase & Manual Valves

H Series Micro

Moduflex Series

H Series ISO

Fieldbus Systems

DX ISOMAX Series

Valvair II Series

Non Plug-in, 5599-1, Sandwich Regulators

PS4037 1 6 6 C P

Basic Series	
H1	
5599-1, Non Plug-in	PS4037
H2	
5599-1, Non Plug-in	PS4137
H3	
5599-1, Non Plug-in	PS4237

Regulator Function	
Common Pressure Regulator	1
Independent Pressure Regulator	2

#2 Port Regulator / Gauge*	
0**	Line By-Pass Plate
4	1-30 PSIG w/Gauge
5	2-60 PSIG w/Gauge
6	5-125 PSIG w/Gauge
D	Remote Pilot ISO 2 & 3 only

* For Common Pressure Regulator Option, Regulator Gauge callout must be the same number for both Port #4 and Port #2. (Example: 166)

** Pressure Line By-Pass Option can only be used with Independent Pressure Regulators.

#4 Port Regulator / Gauge*	
0**	Line By-Pass Plate
4	1-30 PSIG w/Gauge
5	2-60 PSIG w/Gauge
6	5-125 PSIG w/Gauge
D	Remote Pilot ISO 2 & 3 only

* For Common Pressure Regulator Option, Regulator Gauge callout must be the same number for both Port #4 and Port #2. (Example: 166)

** Pressure Line By-Pass Option can only be used with Independent Pressure Regulators.

BOLD OPTIONS ARE MOST POPULAR.

Ordering Components

- Sandwich Regulator Kit configured for Internal Pilot as standard.
- Order valve as External Pilot.

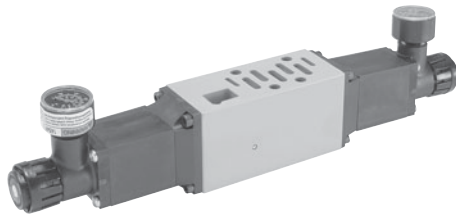

H1 - Size 1
 (Independent Dual Port Regulator Shown)

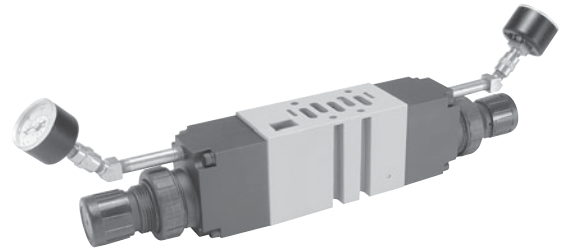

H2 - Size 2
 (Independent Dual Port Regulator Shown)

How to Configure Sandwich Regulator / Valve Combinations

Internal Pilot Configuration of Sandwich Regulator H1, H2 & H3

Pressure in Base Port 1 feeds regulator configured for Internal Pilot which feeds valve configured for External Pilot.

External Pilot Configuration of Sandwich Regulator H1, H2, H3

An External Pilot pressure in Port 12 or 14 of the base feeds thru the Sandwich Regulator 12 or 14 galley directly to the 12/14 pilot of the valve. This configuration takes an External Pilot from the 12 port of the base and passes it thru the regulator to feed the 12 galley of the valve.

Sandwich Regulator Cv Flow Chart*

	Common Pressure Code 166				Single Pressure 2 Code 206				Single Pressure 4 Code 260				Dual Pressure Code 266			
	1-2	1-4	2-3	4-5	1-2	1-4	2-3	4-5*	1-2	1-4	2-3	4-5*	1-2	1-4	2-3	4-5*
H1	0.62	0.61	1.28	1.18	0.73	0.96	0.96	0.93	0.34	0.70	0.94	0.98	0.52	0.48	0.86	0.88
H2	1.47	1.60	2.41	2.33	1.71	1.90	1.52	1.75	1.74	1.67	1.73	1.79	1.61	1.62	1.50	1.67
H3	2.37	2.39	4.30	4.47	2.37	2.81	2.75	3.01	2.65	2.59	2.68	2.74	2.43	2.41	3.16	3.04

* Regulator Port exhaust through Base Port 3.

Note: All Cv's calculated with regulator adjusted full open.



For inventory, lead times, and kit lookup, visit www.pdnplu.com

D120

Parker Hannifin Corporation
 Pneumatic Division
 Richland, Michigan
www.parker.com/pneumatics

D
 Subbase & Manual Valves
 H Series Micro
 Modutef Series
 H Series ISO
 Fieldbus Systems
 DX ISOMAX Series
 Valvair II Series

Non Plug-in, H1, H2, H3 Common Port Regulation

Provides adjustable regulated air pressure to the valve's #1 port which gives the same regulated pressure to both the #2 and #4 port of the manifold or subbase. The regulator is always on the 14 end of the valve.

H2 Common Port Regulator Shown - Double Solenoid, 14 Energized, Internal Pilot

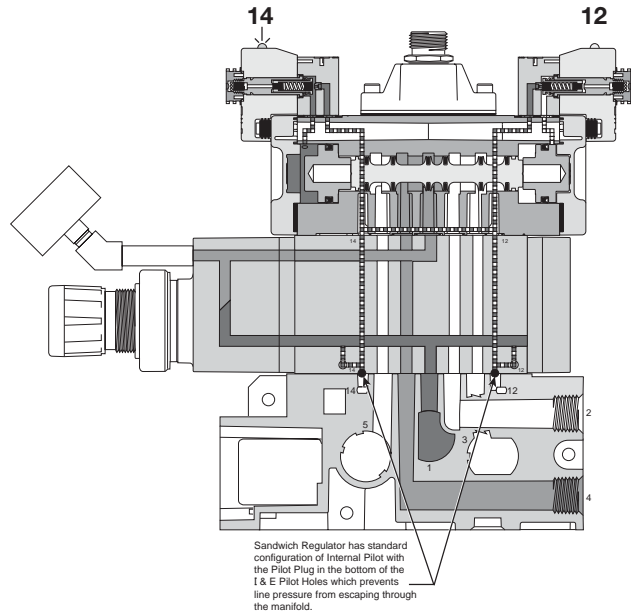
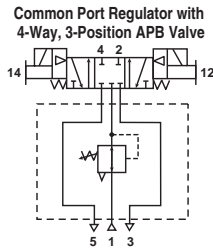
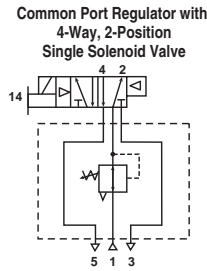

Non Plug-in, H1, H2, H3 Independent Port Regulation

Single Port Regulator

Provides regulated pressure to one of the ports and full line pressure to the other by use of the Line Pressure By-Pass Plate. Pressure regulation can occur out of the #4 port of the valve.

H1 Independent Port Regulator Shown - Double Solenoid, De-energized, Internal Pilot

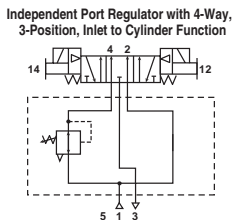
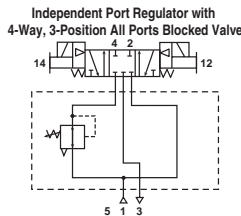

⚠ CAUTION: Requires 4-Way, 3-Position, Cylinder to Exhaust Valve

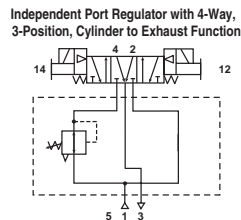

⚠ CAUTION: Requires 4-Way, 3-Position, Inlet to Cylinder Valve

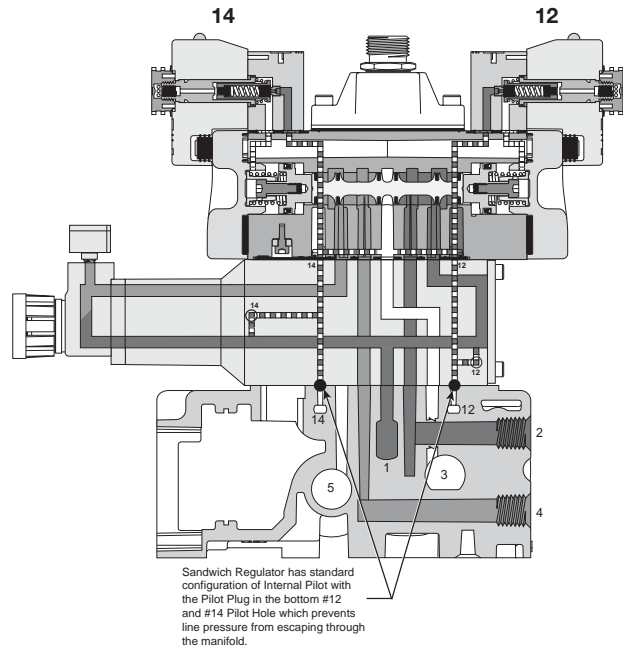

For inventory, lead time, and kit lookup, visit www.pdnplu.com

Non Plug-in, H1, H2, H3 Independent Dual Port Regulation

Dual Port Regulator

Provides regulated pressure to both ports. Pressure regulation can occur out of the #2 or #4 port of the valve.

H1 Independent Dual Port Regulator Shown - Double Solenoid, 14 Energized, Internal Pilot

Independent Dual Port Regulator with 4-Way, 2-Position Double Solenoid Valve

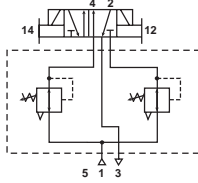

Independent Dual Port Regulator with 4-Way, 3-Position Double Solenoid Valve

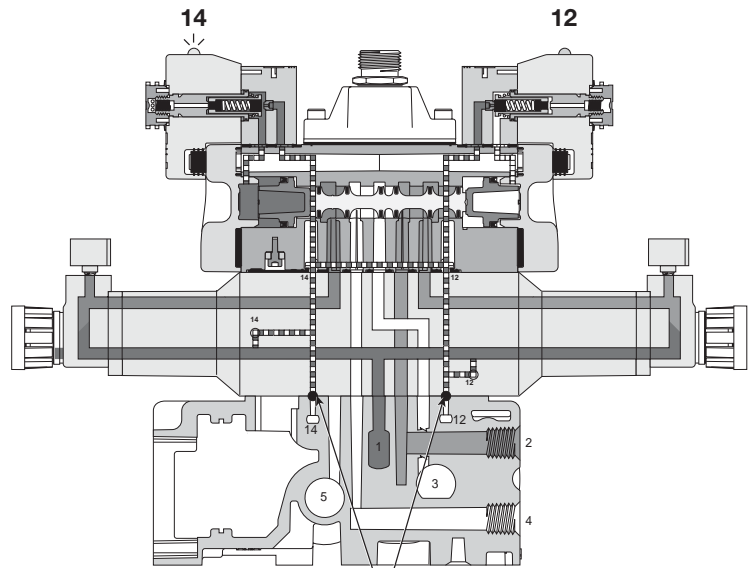
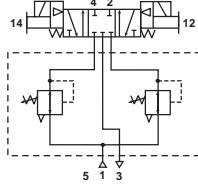

Sandwich Regulator has standard configuration of Internal Pilot with the Pilot Plug in the bottom #12 and #14 Pilot Hole which prevents line pressure from escaping through

When using an Independent Pressure Sandwich Regulator, the cylinder outlet ports are reversed. The 12 end energizes the #4 port and the 14 end energizes the #2 port. The 3-Position CE and PC functions are also reversed. (See schematics on above.)

D	Subbase & Manual Valves
	H Series Micro
	Modulflex Series
	H Series ISO
	Fieldbus Systems
	DX ISOMAX Series
	Valvair II Series



For inventory, lead times, and kit lookup, visit www.pdnplu.com

Remote Pilot, Size 18mm (HB), 26mm (HA), H1, H2, & H3

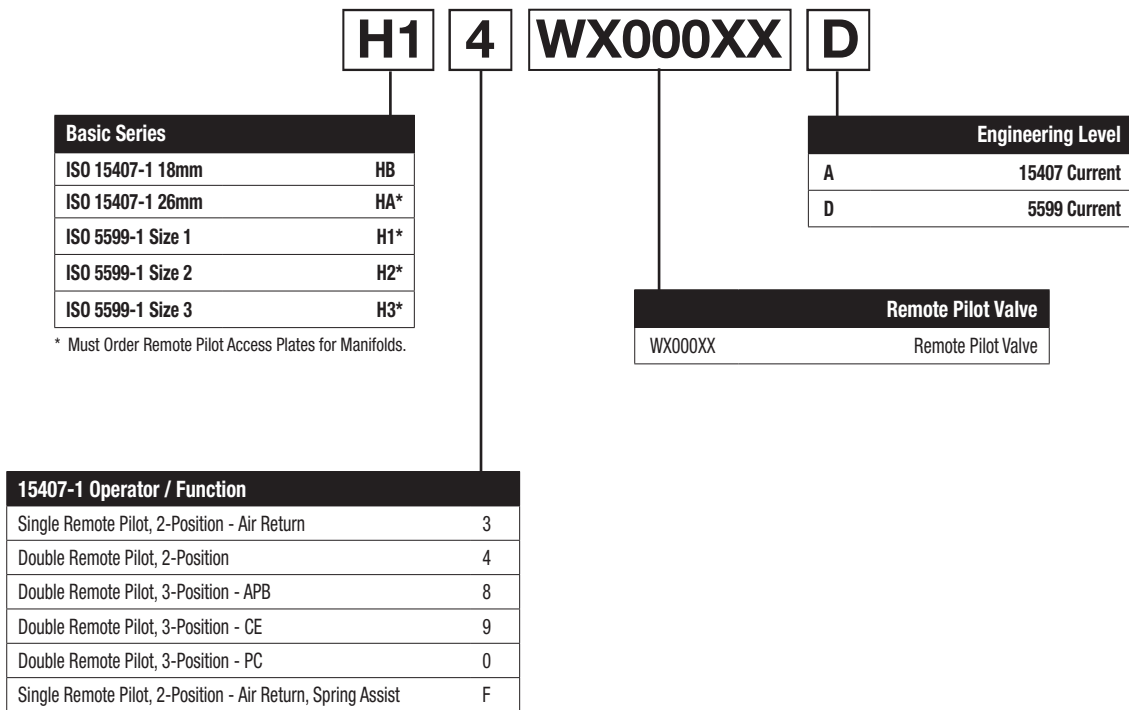

Note: For manifolds, end plates, and accessories, see 15407-1 & 5599-1 Non Plug-in valve section.

Note: HB 18mm Valve Remote Pilot Option only available with PL02 Individual Subbase Kits.

Remote Pilot Access Plate Kits

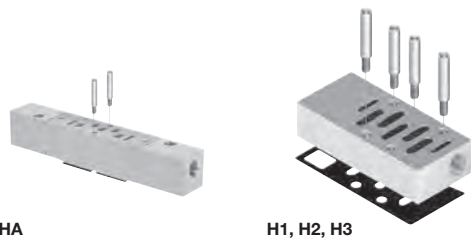

Size	Port size	NPT	BSPP "G"
HA	1/4"	PS551500P	PS551501P
H1	1/8"	PS401500CP	PS401501CP
H2	1/8"	PS411500CP	PS411501CP
H3	1/8"	PS421500CP	PS421501CP

Kit includes: Pilot Port Access Plate, Gasket and Mounting Studs.



For inventory, lead time, and kit lookup, visit www.pdnplu.com

Subbase & Manual Valves	D
H Series Micro	
Moduflex Series	
H Series ISO	
Fieldbus Systems	
DX ISOMAX Series	
Valvair II Series	

Flow Rating (Cv)

Valve size	Port size	2-Position		3-Position	
HB	1/8"	0.55 Cv, C = 1.5 NI/s x bar, b = 0.25, Qn = 390 l/min, Qmax = 648 l/min		0.50 Cv, C = 1.4 NI/s x bar, b = 0.25, Qn = 360 l/min, Qmax = 595 l/min	
HA	1/4"	1.1 Cv, C = 3.6 NI/s x bar, b = 0.30, Qn = 918 l/min, Qmax = 1518 l/min		1.0 Cv, C = 3.3 NI/s x bar, b = 0.30, Qn = 845 l/min, Qmax = 1395 l/min	
H1	3/8"	1.5 Cv, C = 5.0 NI/s x bar, b = 0.30, Qn = 1248 l/min, Qmax = 2070 l/min		1.2 Cv, C = 4.1 NI/s x bar, b = 0.30, Qn = 1000 l/min, Qmax = 1660 l/min	
H2	1/2"	3.0 Cv, C = 9.7 NI/s x bar, b = 0.35, Qn = 2520 l/min, Qmax = 4140 l/min		2.8 Cv, C = 9.0 NI/s x bar, b = 0.35, Qn = 2340 l/min, Qmax = 3860 l/min	
H3	3/4"	6.0 Cv, C = 18.7 NI/s x bar, b = 0.35, Qn = 5022 l/min, Qmax = 7848 l/min		5.0 Cv, C = 15.4 NI/s x bar, b = 0.35, Qn = 4185 l/min, Qmax = 6545 l/min	

Cv tested per ANSI / (NFPA) T3.21.3
 Flow tested According to ISO 6358.

Response Time (ms)**

Valve Size	Port Size	0 Cu. In. Chamber		## Cu. In. Chamber	
		Fill	Exhaust	Fill	Exhaust
Single Solenoid 2-Position - Air Return / Spring Assist					
HB	1/8"	28	30	141	154
HA	1/4"	24	26	77	124
H1	3/8"	39	41	159	210
H2	1/2"	78	81	219	310
H3	3/4"	90	93	244	320

HB (12), HA (25), H1 (50), H2 (100), H3 (200)

** With 100 PSIG supply, time (ms) required to fill from 0 to 90 PSIG and Exhaust from 100 PSIG to 10 PSIG measured from the instant of energizing or de-energizing 24VDC solenoid.

Tested per ANSI / (NFPA) T3.21.8

D

Operating Pressure

Maximum: 145 PSIG (1000 kPa)
Minimum:

Operator / Function	Internal Pilot	PSIG (Min. kPa) HB	PSIG (Min. kPa) HA	PSIG (Min. kPa) H1	PSIG (Min. kPa) H2	PSIG (Min. kPa) H3
1	Single Solenoid - 2-Position	30	25	25	25	35
2	Double Solenoid - 2-Position	(207)	(173)	(173)	(173)	(241)
3	Single Remote Pilot - 2-Position **	Vacuum	Vacuum	Vacuum	Vacuum	Vacuum
4	Double Remote Pilot - 2-Position**	Vacuum	Vacuum	Vacuum	Vacuum	Vacuum
5, 6, 7	Double Solenoid - 3-Position APB, CE, PC	35 (241)	35 (241)	35 (241)	50 (345)	50 (345)
8, 9, 0	Double Remote Pilot - 3-Position** APB, CE, PC	Vacuum	Vacuum	Vacuum	Vacuum	Vacuum
E	Single Solenoid Pilot - 2-Position Air Return / Spring Assist	30 (207)	30 (207)	35 (241)	45 (310)	45 (310)
F	Single Remote Pilot - 2-Position** Air Return / Spring Assist	30 (207)	N/A	N/A	N/A	N/A
N, P, Q	Double Solenoid - Dual 3/2 External Pilot*	*	*	*	*	*
All	H Series	Vacuum	Vacuum	Vacuum	Vacuum	Vacuum

* External Pilot Pressure / Remote Pilot Supply - Must meet or exceed minimum pilot pressure for internal pilot option. Not available on Operator / Function N, P, or Q.

** Must be equal to or greater than operating pressure.

Subbase & Manual Valves

H Series Micro

Modulflex Series

H Series ISO

Fieldbus Systems

DX ISOMAX Series

Valvair II Series



For inventory, lead times, and kit lookup, visit www.pdnplu.com

Minimum Operating Voltage

	HB	HA	H1	H2	H3
MOV (24VDC)	20.4	20.4	20.4	20.4	20.4
MOV (120VAC)	102*	102*	102	102	102

* 120VAC coils have a dropout voltage of 10VAC when used with solid state relays. A pull-down resistor may be necessary.

19-Pin Round Brad Harrison

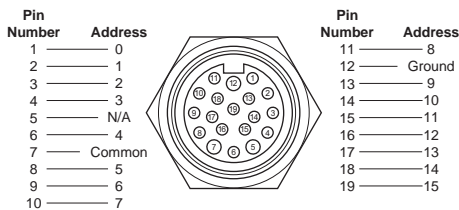

Face View - Male 19-Pin Connector

19-Pin Round Cable Specifications

Common Pin "7" is rated for 8 amps. Cable common wire must be greater than total amperage of solenoids on Add-A-Fold assembly.

Example: 8 station manifold, 16 solenoids, 120VAC - 16 x .039 amps = .63 total amp rating.

NEMA 4 rated with properly assembled NEMA 4 rated cable.

M23, 12-Pin Round Connector (Male)

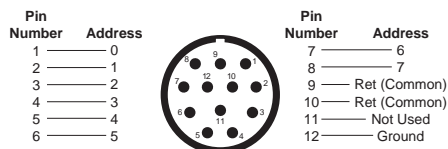

View into End Plate Connector - Male M23, 12-Pin

M23, 19-Pin Round Connector (Male)

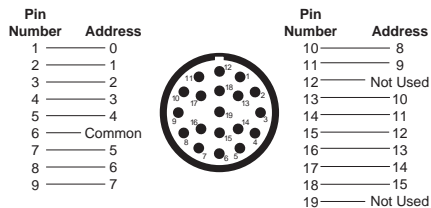

View into End Plate Connector - Male M23, 19-Pin

25-Pin, D-Sub Connector (Male)

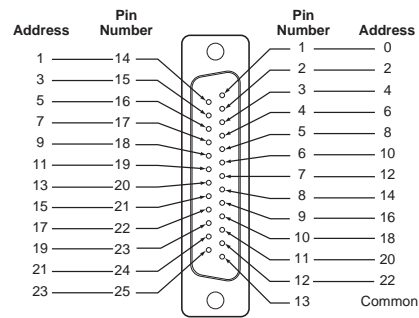

View into End Plate Connector - Male D-Sub, 25-Pin

25-Pin, D-Sub Cable (Female)

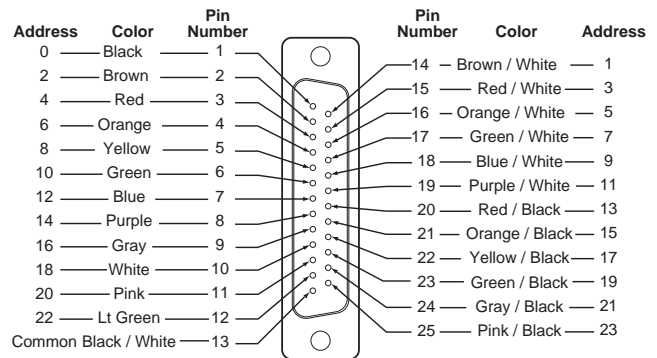

Description	Length	Part number
25-pin, D-sub cable, IP20	3 Meters	P8LMH25M3A
25-pin, D-sub cable, IP20	9 Meters	SCD259D
25-pin, D-sub cable, IP65	3 Meters	SCD253W
25-pin, D-sub cable, IP65	9 Meters	SCD259WE

D

Subbase & Manual Valves

H Series Micro

Moduflex Series

H Series ISO

Fieldbus Systems

DX ISOMAX Series

Valvair II Series



For inventory, lead time, and kit lookup, visit www.pdnplu.com

16-Point Terminal Strip

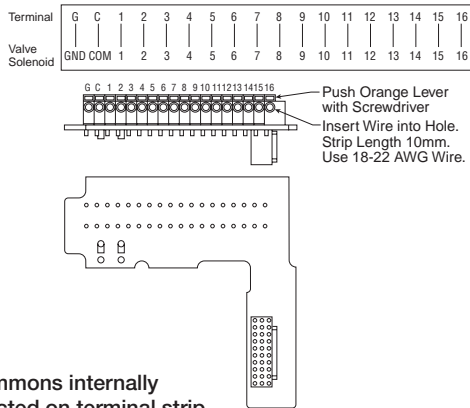

All commons internally connected on terminal strip

Manifold Wiring

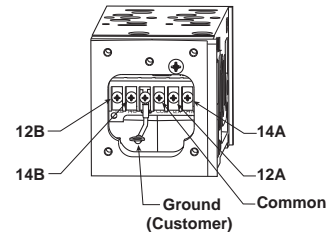

Electrical Connectors - Size 1, 2 & 3

5599-1 CNOMO

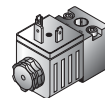

30mm 3-Pin ISO 4400 (DIN 43650A)

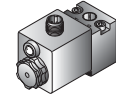

2-Pin M12 Euro

5599-1 AUTO



3-Pin Mini

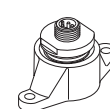

4-Pin Micro

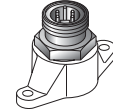

5-Pin Mini

5599-2

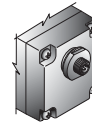

Manifold Auto Connector

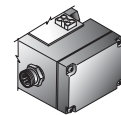

Subbase Auto Connector

Subbase Wiring

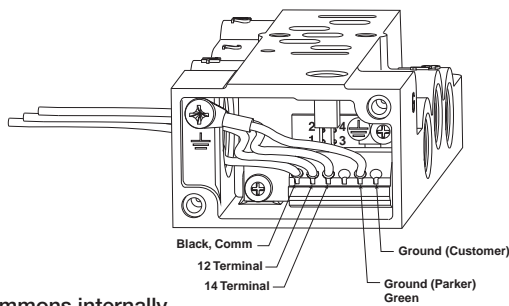

All commons internally connected on terminal strip

Connections

	14 Solenoid	12 Solenoid
Valves with Wires	Black Wires	Red Wires
Valves with Terminal Block (Will accept 18 to 24 Gauge Wires)	14 and Com Terminals	12 and Com Terminals

D
 Subbase & Manual Valves
 H Series Micro
 Modutlex Series
 H Series ISO
 Fieldbus Systems
 DX ISOMAX Series
 Valvair II Series



For inventory, lead times, and kit lookup, visit www.pdnplu.com

Automotive Connection – Wiring Options

'C' Chrysler Connection

5-Pin Male / Single Solenoid
 (Encl. Option 3, Auto Option C)

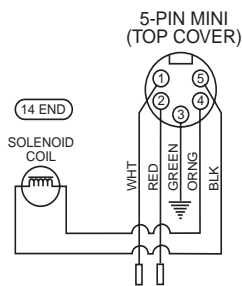

5-Pin Male / Double Solenoid
 (Encl. Option 3, Auto Option C)

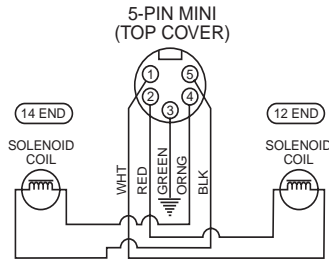

4-Pin Male / Single Solenoid
 (Encl. Option 2, Auto Option C)

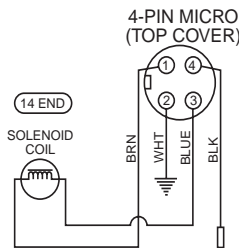

4-Pin Male / Double Solenoid
 (Encl. Option 2, Auto Option C)

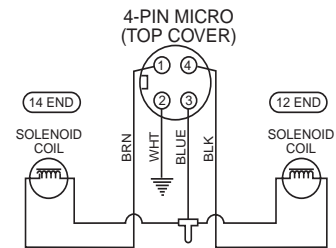

'F' SAE / Ford Wiring

5-Pin Male / Single Solenoid
 (Encl. Option 3, Auto Option F)

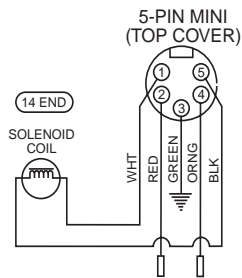

5-Pin Male / Double Solenoid
 (Encl. Option 3, Auto Option F)

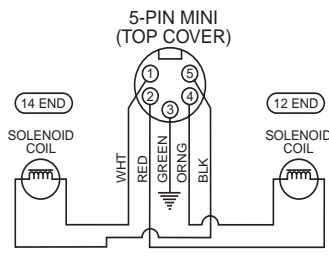

ISO 20401
4-Pin Male / Single Solenoid
 (Encl. Option 2, Auto Option F)

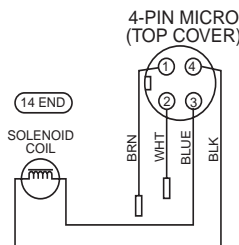

ISO 20401
4-Pin Male / Double Solenoid
 (Encl. Option 2, Auto Option F)

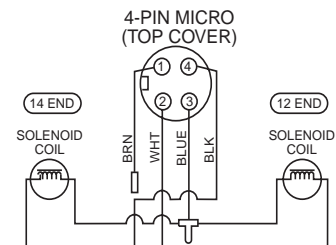

'G' GM Wiring

5-Pin Male / Single Solenoid
 (Encl. Option 3, Auto Option G)

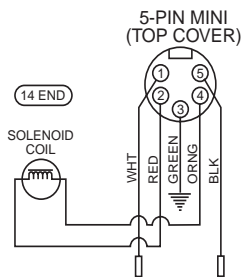

5-Pin Male / Double Solenoid
 (Encl. Option 3, Auto Option G)

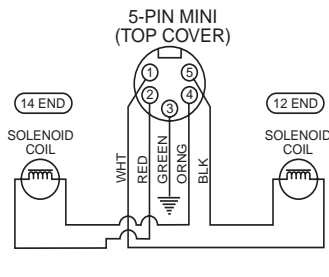

4-Pin Male / Single Solenoid
 (Encl. Option 2, Auto Option G)

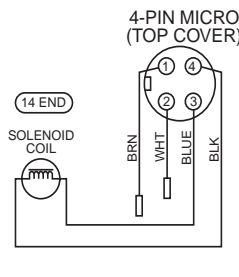

4-Pin Male / Double Solenoid
 (Encl. Option 2, Auto Option G)

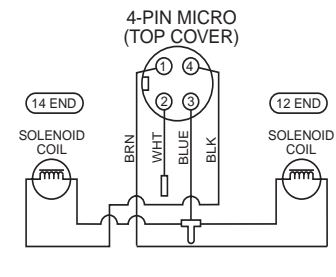

CNOMO Connection - Wiring Options

2-Pin Male / Single Solenoid
 (Encl. Option 6, Auto Option F)

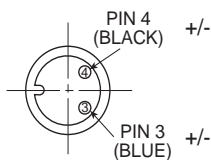

3-Pin Male / Single Solenoid
 (Encl. Option 1, Auto Options C, F & G)

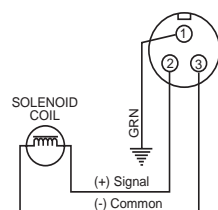

For inventory, lead time, and kit lookup, visit www.pdnplu.com

Maximum Number of Solenoids
(Maximum energized simultaneously)

HA & HB	Voltage code	25-pin D-sub	19-pin Brad Harrison	12-Pin M23	19-pin M23	Moduflex	H Series Fieldbus	Turck	
								16 Outputs	32 Outputs
24VDC	G9	24 (24)	16 (16)	8 (8)	16 (16)	16 (16)	32 (32)	16 (16)	32 (32)
120VAC*	23	24 (24)	16 (16)	8 (8)	16 (16)	N/A	N/A	N/A	N/A

H1, H2 & H3	Voltage code	25-pin D-sub	19-pin Brad Harrison	12-Pin M23	19-pin M23	Moduflex	H Series Fieldbus	Turck	
								16 Outputs	32 Outputs
12VDC	45	24 (13)	16 (13)	8 (8)	16 (13)	N/A	N/A	N/A	N/A
24VAC*	42	24 (24)	16 (16)	8 (8)	16 (16)	N/A	N/A	N/A	N/A
24VDC	B9	24 (20)	16 (16)	8 (8)	16 (16)	16 (16)	24 (21)	16 (16)	24 (21)
120VAC*	23	24 (24)	16 (16)	8 (8)	16 (16)	N/A	N/A	N/A	N/A

* Not CSA certified for 25-pin, D-sub option.

Female Electrical Connectors (IP65 Rated) 30mm, 3-Pin ISO 4400, (DIN 43650A)

Description	Connector with 6' (2m) cord	Connector
Unlighted	PS2028JCP	PS2028BP
Light – 6-48V, 50/60Hz; 6-48VDC	PS2032J79CP*	PS203279BP
Light – 120V/60Hz	PS2032J83CP*	PS203283BP
Light – 240V/60Hz	N/A	PS203283BP

* With surge suppression.

Engineering data:

Conductors: 2 poles plus ground; cable range (connector only): 8 to 10mm (0.31 To 0.39 inch); Contact spacing: 18mm

I/O Addressing Examples

HB & HA Example
Two Station Manifold Bases

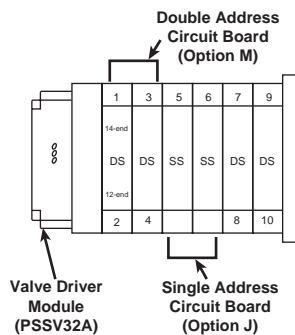

Notes: SS = Single Solenoid Valve
 DS = Double Solenoid Valve
 First output address the #14 end of the valve closest to the valve driver module.

H1, H2 & H3 Example:
Single Station Manifold Bases

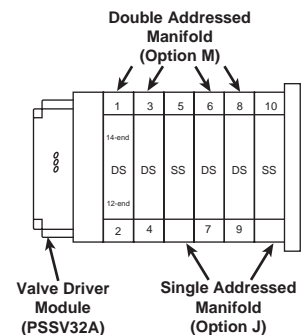

5599-2 & 5599-1 AUTO Solenoid Kits

Valve size	Voltage code	Coil kit number
	42 (24VAC)	PS404142P
	45 (12VDC)	PS404145P
H1, H2 & H3	B9 (24VDC)	PS4041B9P
	23 (120VAC)	PS404123P
	57 (240VAC)	PS404157P

Quantity 1

5599-1 CNOMO Solenoid Kits

Voltage code	3-pin, 30mm 'L' coil kit	2-pin, M12 Euro '6' coil kit
19	—	PS2828619P
42	P2FCA442	—
45	P2FCA445	—
49	P2FCA449	—
53	P2FCA453	—
57	P2FCA457	—

Quantity 1



For inventory, lead times, and kit lookup, visit www.pdnplu.com

D
 Subbase & Manual Valves
 H Series Micro
 Moduflex Series
 H Series ISO
 Fieldbus Systems
 DX ISOMAX Series
 Valvair II Series

Pilot Operator - CNOMO

Valve size		Kit number
H1, H2 & H3	Locking	PS4052CP
	Non-locking	PS4053CP

Manifold Hardware Kits – PS Series

Valve size	Kit number
HB	PS5612P
HA	PS5512P
H1	PS4012P
H2	PS4112P
H3	PS4212P

Quantity 12

Valve Bolt Kits

Valve size	Kit number
HB	PS5687P
HA	PS5587P
H1	PS4087DP
H2	PS4187DP
H3	PS4287DP

Quantity 12

Valve to Base Gasket Kits

Valve size	Standard	Remote pilot	Dual pressure #3	Dual pressure #5
HB	PS5605P*	—	—	—
HA	PS5505P*	—	—	—
H1	PS4005DP	PS4006DP	PS40D3DP	—
H2	PS4105DP	PS4106DP	PS41D3DP	PS41D5DP
H3	PS4205DP	PS4206DP	PS42D3DP	PS42D5DP

Quantity 1

* Quantity 10

Body Service Kits



Valve size	2-position	3-position		
		APB	CE	PC
HB	PS5601P	PS5602P	PS5603P	PS5604P
HA	PS5501P	PS5502P	PS5503P	PS5504P
H1	PS4001CP	PS4002CP	PS4003CP	PS4004CP
H2	PS4101CP	PS4102CP	PS4103CP	PS4104CP
H3	PS4201CP	PS4202CP	PS4203CP	PS4204CP

HB / HA Kit Includes: Spool assembly with seals.

H1, H2, H3 Kit Includes: Spool assembly with seals, all piston seals, return spring, pilot selector gasket, coil to end cap gasket.

Quantity 1

Pilot Select Gasket Kits

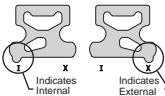
	Valve size	Part number
	HB	PS5605P
	HA	PS5505P
	H1, H2 & H3	PS4007P

Quantity 10

Regulator Kits

Valve size	Part number
H1	PS4039P
H2, H3	PS4139P

Manifold Hardware Kit – PJJ Series

Description	Part number
Bolt, Washer & Nut	DX02M2MB*

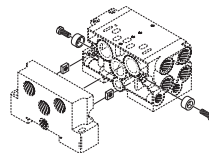

* Includes 10 Bolts, 10 Washers, 10 Nuts



For inventory, lead time, and kit lookup, visit www.pdnplu.com

Regulator & Flow Control Mounting Studs

Valve type	Type	Part number
HB	Flow Control & Regulator	PS5636P
HA	Flow Control & Regulator	PS5536P
H1	Flow Control	PS4036P
	Regulator	PS4040P
H2	Flow Control	PS4136P
	Regulator	PS4140P
H3	Flow Control	PS4236P
	Regulator	PS4240P

Quantity 12

Regulator Gauge Kits – Size H1, H2 & H3

Gauge type	Part number
1" Face Air - Standard	
0 to 60 PSIG	PS4051060BP
0 to 160 PSIG	PS4051160BP
1-1/2" Face Air - Large*	
0 to 60 PSIG	PS4053060BP
0 to 160 PSIG	PS4053160BP
1-1/2" Face Liquid*	
0 to 160 PSIG	PS4052160BP

* Includes brass pipe fitting extensions
Quantity 1

Regulator Spring Range Kits – Size H1, H2 & H3

Spring range	Valve size	Part number
0 to 30 PSIG	H1	PS4050030P
	H2, H3	PS4150030BP
2 to 60 PSIG	H1	PS4050060P
	H2, H3	PS4150060BP
5 to 125 PSIG	H1	PS4050125P
	H2, H3	PS4150125BP

Quantity 1

Regulator Conversion Kits – Size H1, H2 & H3

Valve size	Description	Part number
H1	Manual Bonnet Assembly (w/o Spring)	PS4045BP
	Air Pilot Bonnet Assembly	PS4047BP
	Independent By-Pass Plate	PS4048BP
H2, H3	Manual Bonnet Assembly (w/o Spring)	PS4145BP
	Air Pilot Bonnet Assembly	PS4147BP
	Independent By-Pass Plate	PS4148BP

Quantity 1

Pilot By-Pass Plate

Valve size	Part number
H1, H2, H3	PS4051P

Quantity 10

Valve Driver Module

Driver Module	Part number
32 Point Module – HB, HA, H1, H2, H3	PSSV32A*†
24 Output Cable – HB, HA	PS5624P †
25 - 32 Output Cable – HB, HA	PS5632P †
24 Output Cable – H1, H2, H3	PS4024P †



PSSV32A

* Reference Document E100P for Installation Instructions. See www.pdnplu.com

† H Series Fieldbus Add-A-Fold assemblies and end plate kits include a valve driver module (PSSV32A) and cable.

HB / HA 24 output manifolds require a PS5624P.

HB / HA 32 output manifolds require a PS5624P + PS5632P.

H1, H2, H3 manifolds require a PS4024P, allowing 21 outputs.

D

Subbase & Manual Valves

H Series Micro

Moduteflex Series

H Series ISO

Fieldbus Systems

DX ISOMAX Series

Valvair II Series



For inventory, lead times, and kit lookup, visit www.pdnplu.com

H Series ISO 15407-2, Plug-in, Size 18mm (HB)

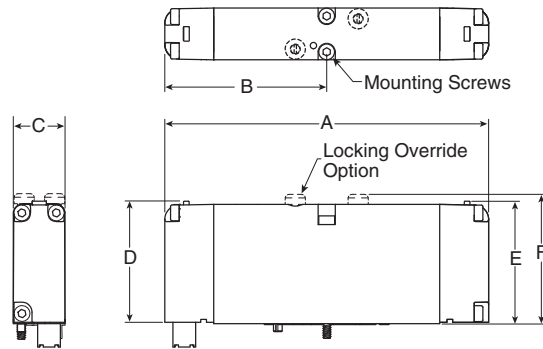

18mm Dimensions

A	B	C	D
4.43	2.22	.72	1.98
(113)	(56)	(18)	(50)

E	F
1.68	1.77
(43)	(45)

Inches (mm)

H Series ISO 15407-2, Plug-in, Size 26mm (HA)

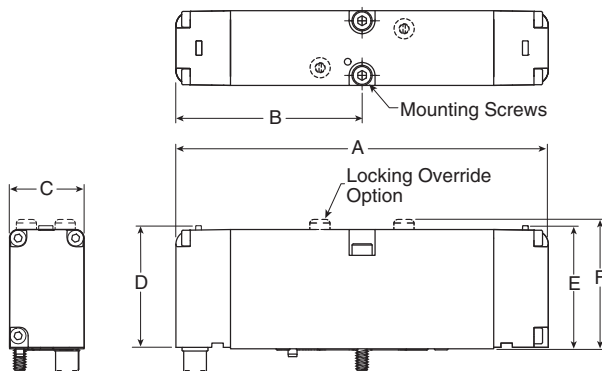

26mm Dimensions

A	B	C	D
5.10	2.55	1.02	1.98
(130)	(65)	(26)	(50)

E	F
1.68	1.77
(43)	(45)

Inches (mm)

H Series ISO 15407-1, Non Plug-in, Size 18mm (HB)

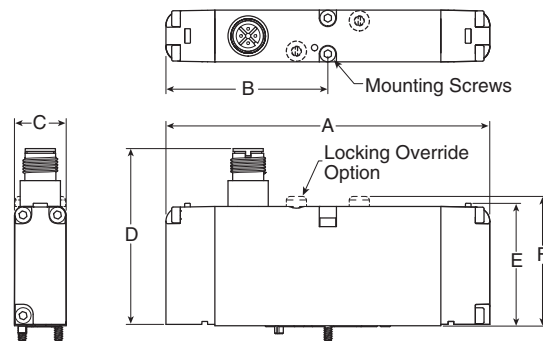

18mm Dimensions

A	B	C	D
4.43	2.22	.72	2.40
(113)	(56)	(18)	(61)

E	F
1.68	1.77
(43)	(45)

Inches (mm)

H Series ISO 15407-1, Non Plug-in, Size 26mm (HA)

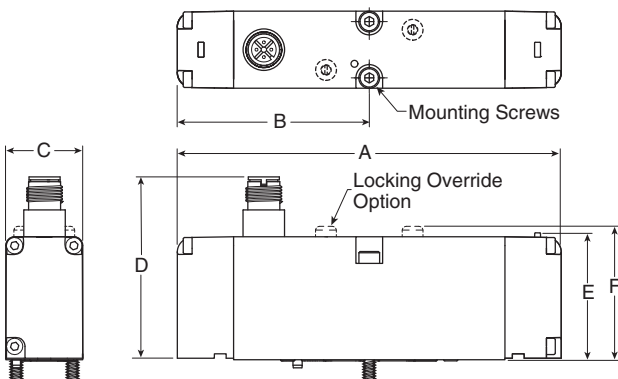

26mm Dimensions

A	B	C	D
5.10	2.55	1.02	2.40
(130)	(65)	(26)	(61)

E	F
1.68	1.77
(43)	(45)

Inches (mm)



For inventory, lead time, and kit lookup, visit www.pdnplu.com

D131

Parker Hannifin Corporation
 Pneumatic Division
 Richland, Michigan
www.parker.com/pneumatics

D	Subbase & Manual Valves
	H Series Micro
Moduflex Series	
H Series ISO	
Fieldbus Systems	
DX ISOMAX Series	
Valvair II Series	

H Series ISO 5599-2

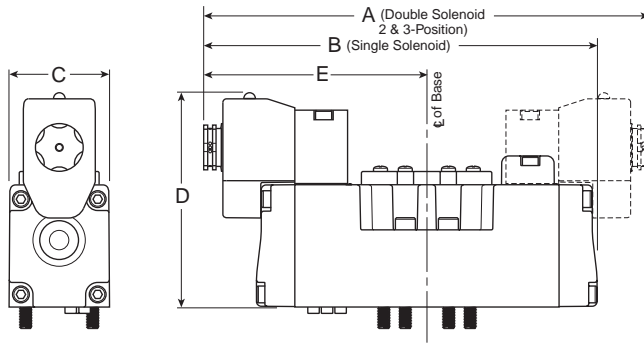

H1 Valves Shown

H1 Dimensions

A	A ₁	B	C
7.32 (186)	5.59 (142)	6.46 (164)	1.65 (42)
D	D ₁	D ₂	D ₃
3.54 (90)	4.29 (109)	4.29 (109)	2.50 (63.5)
D ₄	E	E ₁	
2.48 (63)	3.66 (93)	2.80 (71)	

Inches (mm)

H Series ISO 5599-1 Auto

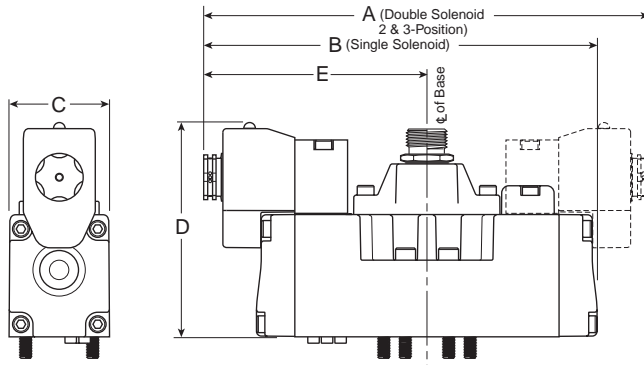

H2 Dimensions

A	A ₁	B	C
8.35 (212)	6.62 (168)	7.48 (190)	2.17 (55)
D	D ₁	D ₂	D ₃
4.05 (103)	4.80 (122)	4.57 (116)	2.99 (76)
E	E ₁		
4.17 (106)	3.31 (84)		

Inches (mm)

H Series ISO 5599-1 CNOMO

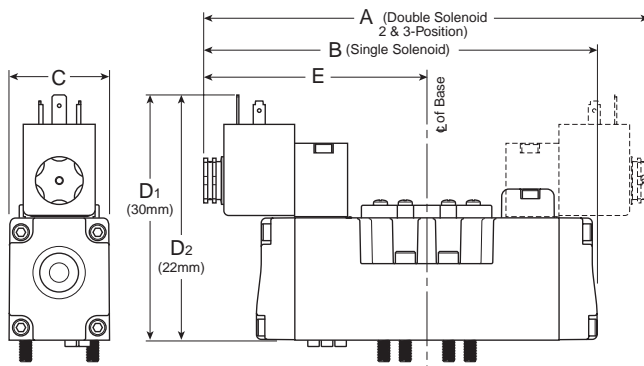

H3 Dimensions

A	A ₁	B	C
9.68 (246)	6.98 (177)	8.68 (220)	2.17 (55)
D	D ₁	D ₂	D ₃
4.05 (103)	4.80 (122)	4.57 (116)	2.99 (76)
E	E ₁		
4.74 (121)	3.49 (89)		

Inches (mm)

H Series ISO 5599-2 / 5599-1 Remote Pilot

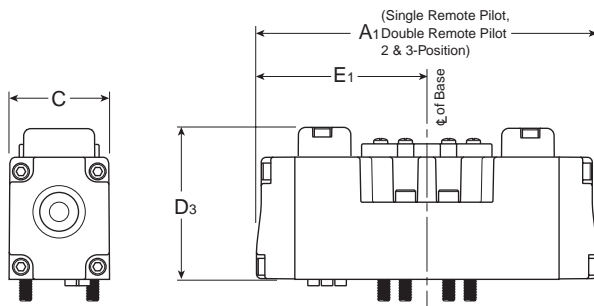

D

Subbase & Manual
Valves

H Series
Micro

Modulflex
Series

H Series
ISO

Fieldbus
Systems

DX ISOMAX
Series

Valvair II
Series



For inventory, lead times, and kit lookup, visit www.pdnplu.com

H Series ISO 15407-2 & 15407-1 Size 26mm (HA), Plug-in Subbases

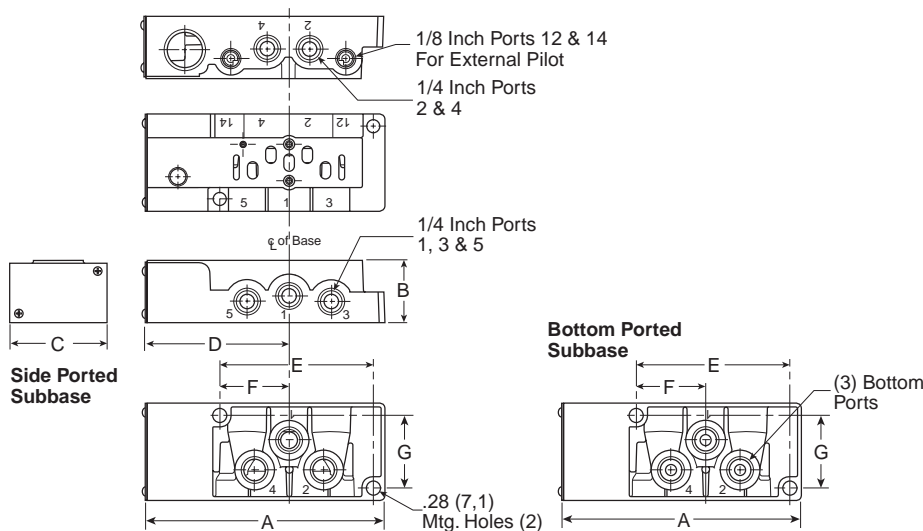

HA Dimensions

A	B	C	D
4.88 (124)	1.28 (32.5)	2.00 (50.8)	2.91 (74)
E	F	G	
1.43 (36.2)	3.16 (80.2)	1.49 (37.9)	

Inches (mm)

H Series ISO 15407-2 & 15407-1 Size 18mm (HB) & 26mm (HA), PS5611 & PS5511 Manifolds

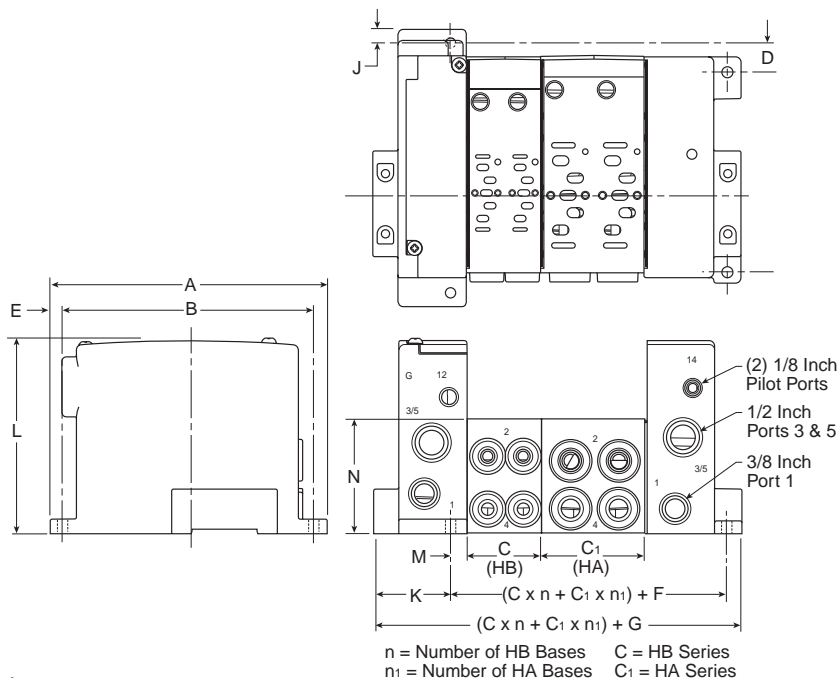

HB & HA Dimensions

A	B	C	C ₁	D	E
5.98 (152)	5.39 (137)	1.61 (40.8)	2.24 (56.8)	.63 (16)	.30 (7.5)
F	G	H	J	K	L
2.14 (54.4)	4.12 (104.6)	4.32 (109.8)	.15 (4)	1.68 (42.7)	4.17 (106)
M	N				
.33 (8.4)	2.48 (63)				

Inches (mm)

Note:
 See Fieldbus Section for the dimensions of manifolds utilizing the H Series Fieldbus, Turck, or Moduflex end plate type.

n = Number of HB Bases C = HB Series
 n₁ = Number of HA Bases C₁ = HA Series



For inventory, lead time, and kit lookup, visit www.pdnplu.com

D	Subbase & Manual Valves
H Series Micro	Moduflex Series
H Series ISO	Fieldbus Systems
DX ISOMAX Series	Valvair II Series

H Series ISO 5599-1 Size H1, PS4011 Subbase

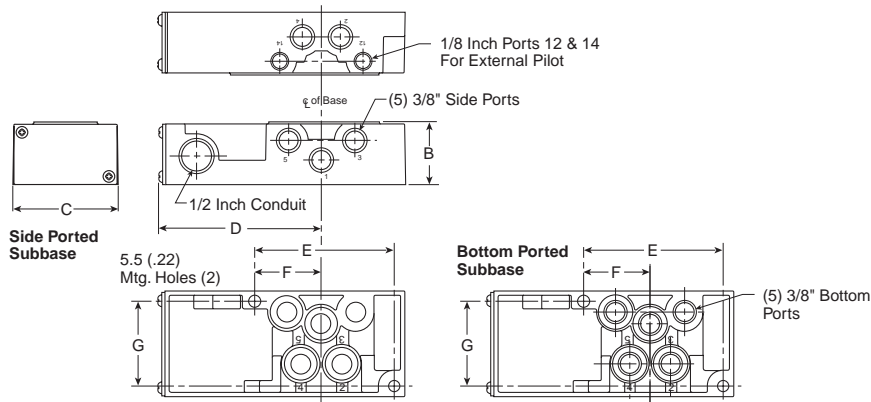

PS4011 Subbase Dimensions

A	B	C	D
5.83	1.48	2.50	3.86
(148)	(38)	(64)	(98)

E	F	G
3.29	1.57	2.00
(84)	(40)	(51)

Inches (mm)

H Series ISO 5599-1 Size H2, PS4111 Subbase

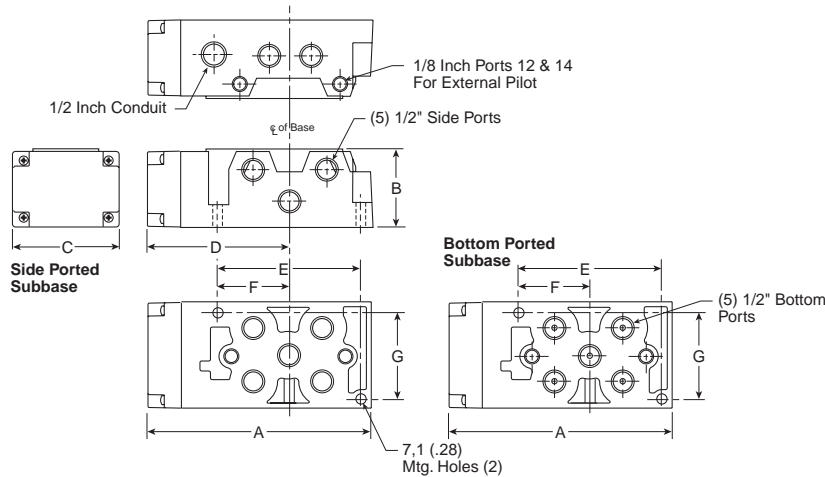

PS4111 Subbase Dimensions

A	B	C	D
6.69	2.33	3.15	4.25
(170)	(59)	(80)	(108)

E	F	G
4.21	2.07	2.56
(107)	(52)	(65)

Inches (mm)

H Series ISO 5599-1 Size H3, PS4211 Subbase

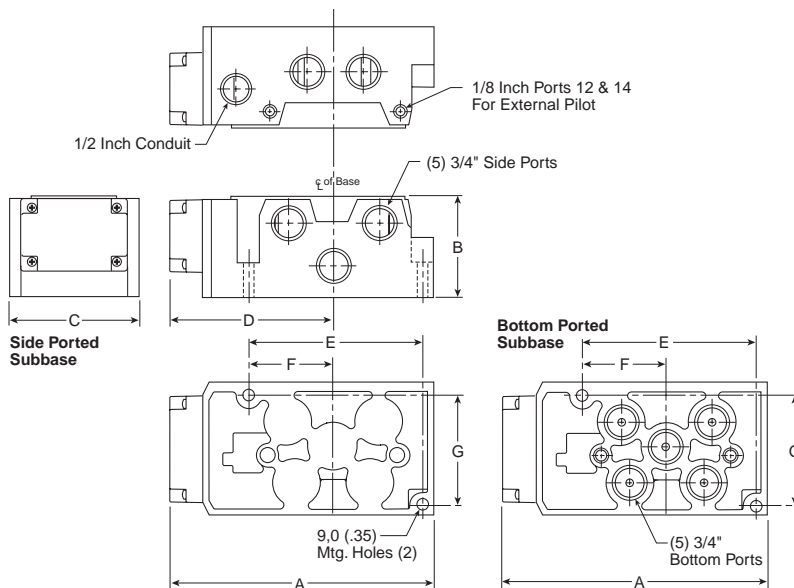

PS4211 Subbase Dimensions

A	B	C	D
7.90	2.96	3.90	4.92
(201)	(75)	(99)	(125)

E	F	G
5.14	2.50	3.24
(131)	(64)	(82)

Inches (mm)

D
 Subbase & Manual Valves
 H Series Micro
 Modutrex Series
 H Series ISO
 Fieldbus Systems
 DX ISOMAX Series
 Valvair II Series



For inventory, lead times, and kit lookup, visit www.pdnplu.com

D134

Parker Hannifin Corporation
 Pneumatic Division
 Richland, Michigan
www.parker.com/pneumatics

H Series ISO 5599 Size H1, PS4011 Manifold

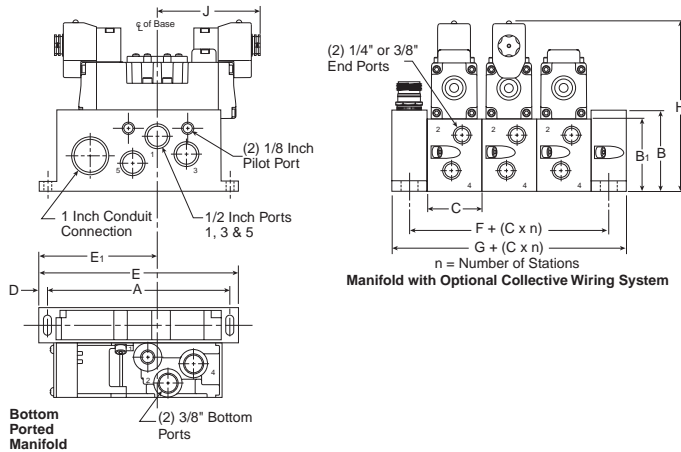

PS4011 Manifold Dimensions

A	B	B ₁	C	D
6.50 (165)	2.87 (73)	2.64 (67)	1.96 (50)	.33 (8)
E	E ₁	F	G	H
7.15 (182)	4.25 (108)	1.25 (32)	2.50 (63.5)	6.18 (157)
J	3.66 (93)			

Inches (mm)

H Series SO 5599 Size H2, PS4111 Manifold

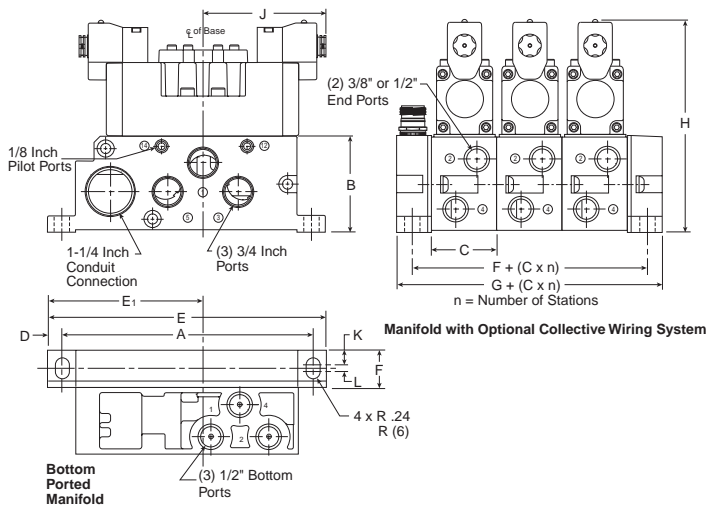

PS4111 Manifold Dimensions

A	B	C	D	E
8.46 (215)	3.35 (85)	2.20 (56)	.47 (12)	9.41 (239)
E ₁	F	G	H	J
5.28 (134)	1.26 (32)	2.60 (63)	7.40 (188)	4.17 (106)
K	L			
.65 (16.5)	.24 (6)			

Inches (mm)

H Series ISO 5599 Size H3, PS4211 Manifold

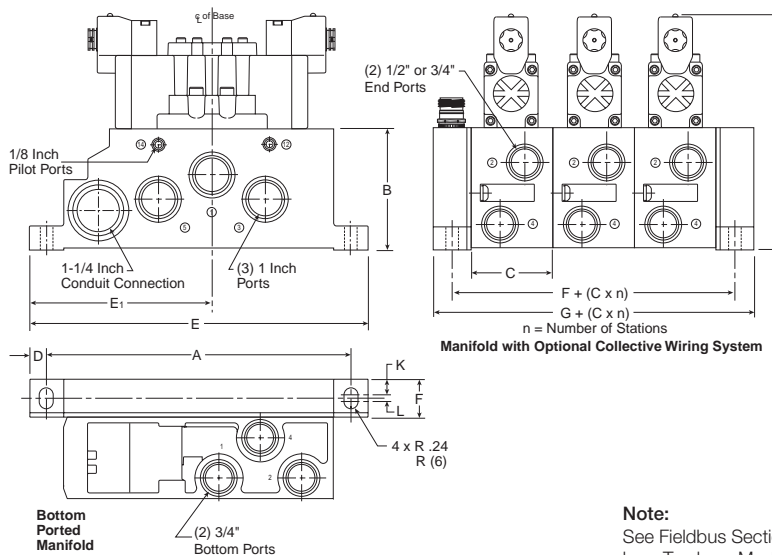

PS4211 Manifold Dimensions

A	B	C	D	E
10.41 (265)	4.13 (105)	2.80 (71)	.59 (15)	11.61 (295)
E ₁	F	G	H	
6.26 (159)	1.30 (33)	2.60 (63)	8.19 (208)	
K	L			
.53 (13.5)	.24 (6)			

Inches (mm)

Note:

See Fieldbus Section for the dimensions of manifolds utilizing the H Series Fieldbus, Turck, or Modflex end plate type.



For inventory, lead time, and kit lookup, visit www.pdnplu.com

D135

Parker Hannifin Corporation
 Pneumatic Division
 Richland, Michigan
www.parker.com/pneumatics

D

Subbase & Manual Valves

H Series Micro

Modflex Series

H Series ISO

Fieldbus Systems

DX ISOMAX Series

Valvair II Series

H Series ISO 15407 Sandwich Regulator

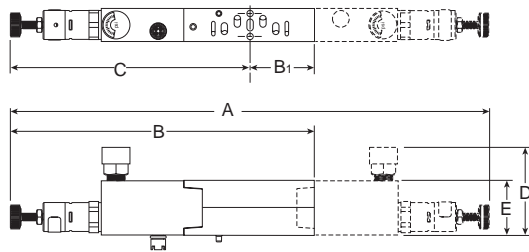

Series	Part number	A	B	B ₁	C	D	E
HB	PS5637	10.28 (261)	6.14 (156)	1.02 (26)	5.13 (130)	2.60 (66)	1.18 (30)
HA	PS5537	10.00 (254)	6.42 (163)	1.42 (36)	5.00 (127)	2.72 (69)	1.18 (30)

Inches (mm)

H Series ISO 5599, Size H1 Sandwich Regulator

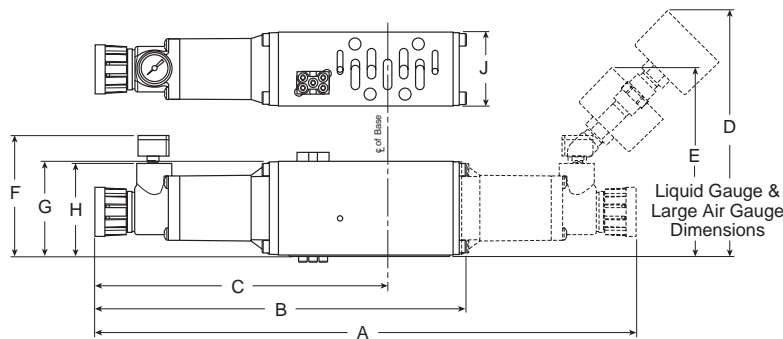

Series	Part number	A	B	C	D	E	F	G	H	J
H1	PS4037	11.84	8.13	6.40	5.45	4.25	2.85	2.09	2.05	1.63
	PS4038	(301)	(207)	(163)	(138)	(108)	(72)	(53)	(52)	(41)

Inches (mm)

H Series ISO 5599, Size H2 & H3 Sandwich Regulator

H2 Sandwich Regulator Shown

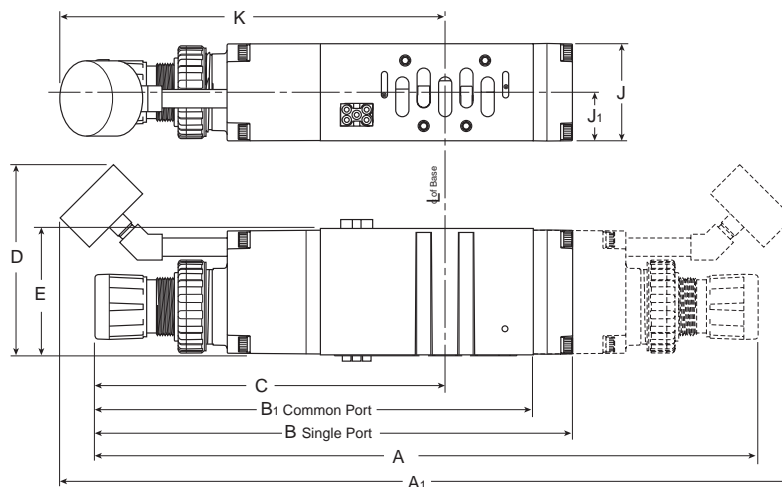

Series	Part number	A	A ₁	B	B ₁	C	D	E	J	J ₁	K
H2	PS4137	14.65	16.18	10.56	9.84	7.71	4.20	2.80	2.15	1.07	8.50
	PS4138	(372)	(411)	(268)	(250)	(196)	(107)	(71)	(55)	(27)	(216)
H3	PS4237	15.67	17.15	11.53	10.67	8.37	4.20	2.93	2.50	1.25	9.10
	PS4238	(398)	(436)	(293)	(271)	(213)	(107)	(75)	(64)	(32)	(231)

Inches (mm)

D
 Subbase & Manual Valves
 H Series Micro
 Moduteflex Series
 H Series ISO
 Fieldbus Systems
 DX ISOMAX Series
 Valvair II Series



For inventory, lead times, and kit lookup, visit www.pdnplu.com

D136

Parker Hannifin Corporation
 Pneumatic Division
 Richland, Michigan
www.parker.com/pneumatics

H Series ISO 15407, Size 18mm (HB) & 26mm (HA), Flow Control

HA Flow Control

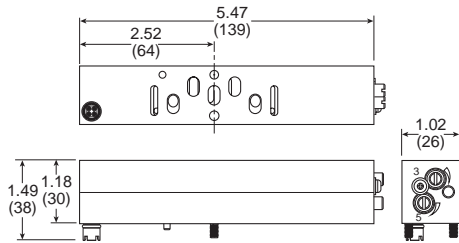

HB Flow Control

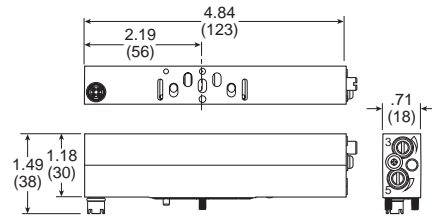

H Series ISO 5599, Size H1, H2 & H3, Flow Control

H1 Flow Control

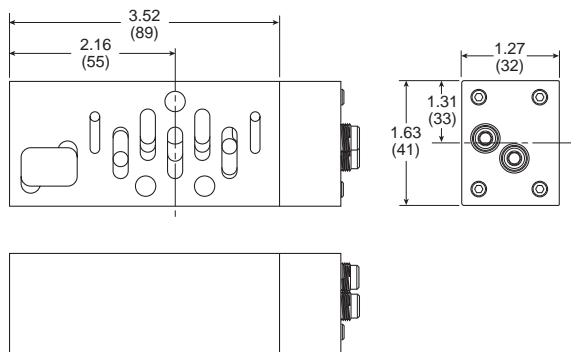

H2 Flow Control

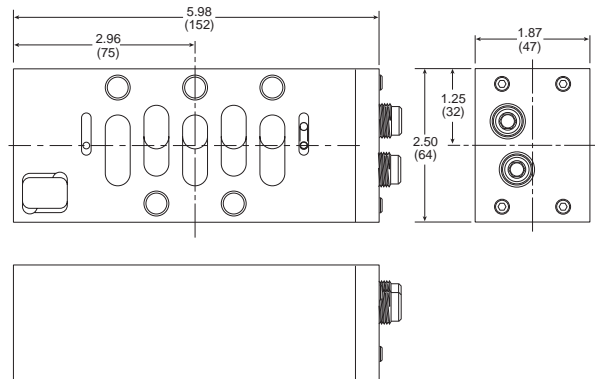

H3 Flow Control

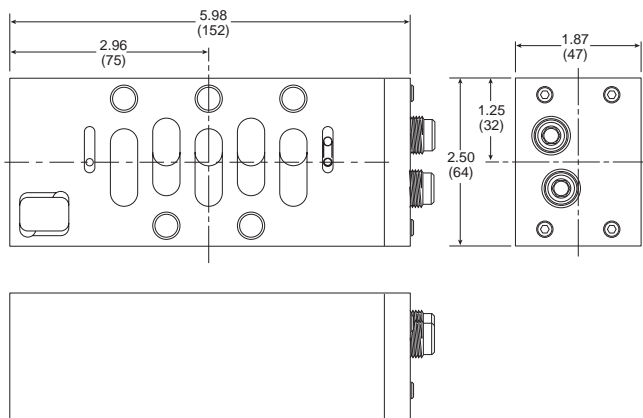

D

Subbase & Manual Valves

H Series Micro

Moduflex Series

H Series ISO

Fieldbus Systems

DX ISOMAX Series

Valvair II Series



For inventory, lead time, and kit lookup, visit www.pdnplu.com

Features

Fieldbus Systems

Fieldbus Offering

Valve series	Moduflex	H Series	Turck
Moduflex	X		
H Series Micro	X	X	X
H Series ISO	X	X	X

Protocol	Moduflex	H Series	Turck
IO-Link	X		
DeviceNet	X	X	X
Ethernet/IP		X	X
Profibus-DP	X	X	X
Profinet			X
Modbus/TCP			X
AS-i	X		
CANopen	X		X
Interbus-S	X		
ControlNet		X	

Options	Moduflex	H Series	Turck
Digital inputs / outputs*		X	X
Analog inputs / outputs		X	X
16 Solenoid control*	X		X
32 Solenoid control		X	X
Short circuit protection on inputs			X
Current sensing outputs			X
Bus expansion		X	
DeviceNet subnet			X
Programmable comm modules			X
Power over DeviceNet / CANopen			X
Preferred connectivity		X	
CANopen expansion			X

* Moduflex AS-i modules are available with 6 or 8 inputs and 6 or 8 solenoid outputs

The Moduflex Fieldbus System

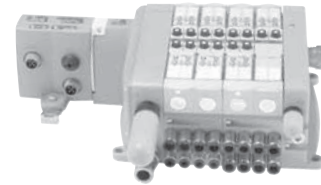

The H Series Fieldbus System

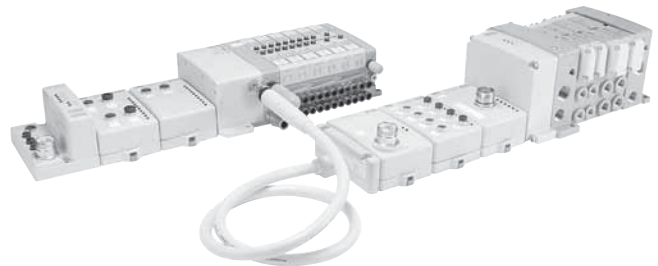

The Turck Fieldbus System

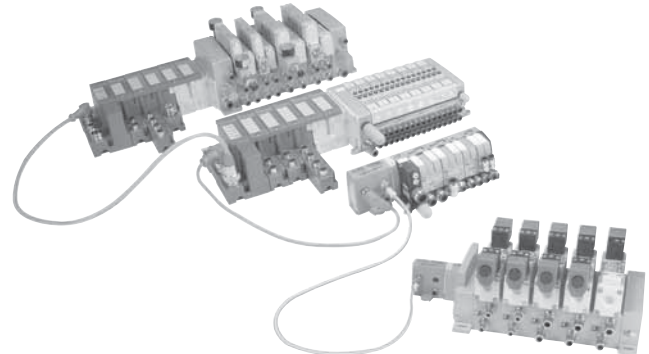

	Turck fieldbus	H Series Fieldbus	Moduflex
Solenoid control	Up to 32 solenoids on main valve manifold. DeviceNet Subnet Allows an additional 32 solenoids per node 63 nodes maximum. CANopen expansion Allows an additional 64 solenoids per expansion 5 expansions maximum.	Up to 32 solenoids on main valve manifold H Series Micro Bus Expansion Allows an additional 32 solenoids per expansion 3 expansions maximum 1 meter fixed cable length per expansion	Up to 24 solenoids on main valve manifold 19 Moduflex 24 H Micro 24 H Series ISO
I/O capabilities	256 maximum inputs and outputs directly connected to communication module. DeviceNet Subnet Allows an additional 256 I/O per node 63 nodes maximum Third party DeviceNet modules can be used CANopen expansion Allows an additional 64 I/O per expansion 5 expansions maximum Third party CANopen modules can be used	Maximum of 256 inputs and 256 outputs directly connected to the communication module, including H Series Micro Bus Expansion.	8 Inputs available on AS-i communication only.
Short circuit protection	SXG and diagnostic electronic modules have each point isolated. All other electronic modules are isolated from the backplane.	Devices must be fused between input / output and electronic module.	

Most popular.

D Subbase & Manual Valves H Series Micro Moduflex Series H Series ISO Fieldbus Systems DX ISOMAX Series Valvair II Series



For inventory, lead times, and kit lookup, visit www.pdnplu.com

D138

Parker Hannifin Corporation
 Pneumatic Division
 Richland, Michigan
www.parker.com/pneumatics

Features

The Moduflex Fieldbus System

Moduflex communication modules directly attach to the end plate. It offers a compact and low cost fieldbus solution.

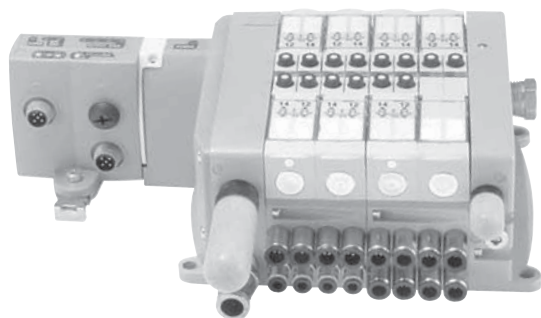

Moduflex Features

- Small, compact product design
- IO-Link Class A & B modules
- Broad protocol offering, including DeviceNet, Profibus, AS-i, CANopen, and InterBus
- Channel-level diagnostics (LED and Electronic)
- Inputs available with AS-i modules
- Horizontal and vertical mounting without derating
- 5g vibration
- Quick-disconnects for I/O and network connectivity
- Built-in panel grounding
- CE certification

Control for up to 24 solenoids

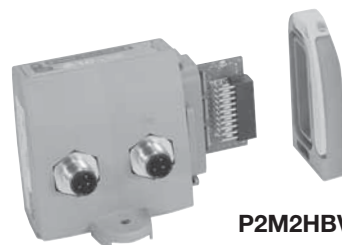

P2M2HBVL1240013
(Type A shown)

Control for up to 16 solenoids



P2M2HBVP11600
(Profibus shown)

Moduflex Communication Modules

IO-Link		Part number
Class A	3-Pin, Aux power 1 & 3	P2M2HBVL12400A13
	3-Pin, Aux power 4 & 3	P2M2HBVL12400A43
	3-Pin, Aux power 4 & 2	P2M2HBVL12400A42
Class B	5-Pin, Aux power 2 & 5	P2M2HBVL12400B25

Bus protocol	Part number
Profibus DP	P2M2HBVP21600
DeviceNet	P2M2HBVD21600
CANopen	P2M2HBVC21600
InterBus-S	P2M2HBVS11600

Most popular.



For inventory, lead time, and kit lookup, visit www.pdnplu.com

D	Subbase & Manual Valves
H Series Micro	Moduflex Series
H Series ISO	Fieldbus Systems
DX ISOMAX Series	Valvair II Series

“V” Series Valve Island
Electrical fieldbus head module for IO-Link

Electrical Module for 19 outputs (Moduflex Pilot Valves)
 (The last 5 outputs of this 24 DO module can't be used with Moduflex Valve)

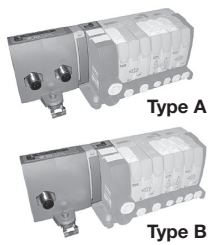

Description	IO-Link Class	M12 A coded Connector connection		Aux. Power Pinout	Weight (g)	Part number
		IO-Link	Aux. Power			
Moduflex IO-Link Communication Module	Class A	3 Pin's	3 Pin's	1 & 3	160	P2M2HBVL12400A13
		3 Pin's	3 Pin's	4 & 3	160	P2M2HBVL12400A43
		3 Pin's	5 Pin's	4 & 2	160	P2M2HBVL12400A42
	Class B	5 Pin's		2 & 5	140	P2M2HBVL12400B25
Power & Communication Cable						RKC 4.5T*-RSC 4.5T/S1587

IODD file can be downloaded from IODD Finder or the Moduflex web site:
<https://ioddfinder.io-link.com> or www.parker.com/pdn/io-link

Where * = 1, 2, 3, 4, 5, 10, 20 meter standard lengths

Moduflex Class A module with independent Auxiliary Power Supply

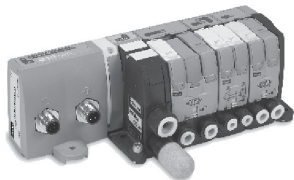

The Moduflex **IO-Link** Class A module can handle a Moduflex Valve bank having up to 19 pilot solenoid valves.

Thanks to its 2 x M12 A coded male connectors, it can be connected to any IO-Link Class A master and separately receive its auxiliary power supply for valves from an independent source.

The Moduflex **IO-Link** Class A module exists in 3 versions with the Auxiliary Power M12 connector pin out adapted to any sourcing through a standard M12 cable:

- P2M2HBVL12400A13 version: 24VDC / 0VDC on pins 1 & 3 – Standard version
- P2M2HBVL12400A43 version: 24VDC / 0VDC on pins 4 & 3 – Compatible with Siemens wiring
- P2M2HBVL12400A42 version: 24VDC / 0VDC on pins 4 & 2 – Compatible with Rockwell wiring and Turck

Moduflex Class B module

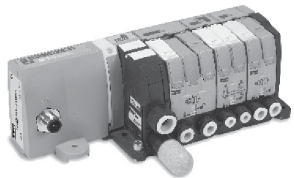

The Moduflex **IO-Link** Class B module can handle a Moduflex Valve bank having up to 19 pilot solenoid valves.

Thanks to its single M12 A coded male connectors, it can be connected to any IO-Link Class B master receiving its auxiliary power supply for valves on pins 2 & 5 from the only cable simplifying the connection.

- P2M2HBVL12400B25 version: 24VDC / 0VDC on pins 2 & 5

Diagnostic



The Moduflex **IO-Link** module offers a local diagnostic through 4 LED's located on the visible top side, showing:

- IO-Link com status
- Module error
- Output error
- Auxiliary power

Additional useful diagnostic information can be read by the PLC through the network simplifying diagnostic and allowing predictive maintenance (all details in the user manual).

Most popular.

Auxiliary power for safe supply

The Moduflex **IO-Link** module is compatible with SAFE power source for valve control.

For more details, refer to next page.

D
 Subbase & Manual Valves
 H Series Micro
 Moduflex Series
 H Series ISO
 Fieldbus Systems
 DX ISOMAX Series
 Valvair II Series



For inventory, lead times, and kit lookup, visit www.pdnplu.com

D139a

Parker Hannifin Corporation
 Pneumatic Division
 Richland, Michigan
www.parker.com/pneumatics

IO-Link module connection and diagnostic functions



IO-Link module connection

Standard male M12 – type A

Usage of standard manufactured cables available from your usual electrical supplier is recommended.

Note: Auxiliary power for solenoids can be wired allowing the user to turn outputs off while the communications remains on.

Configuration

IODD file can be downloaded from IODD Finder or the Moduflex web site:
<https://ioddfinder.io-link.com>
www.parker.com/pdn/io-link

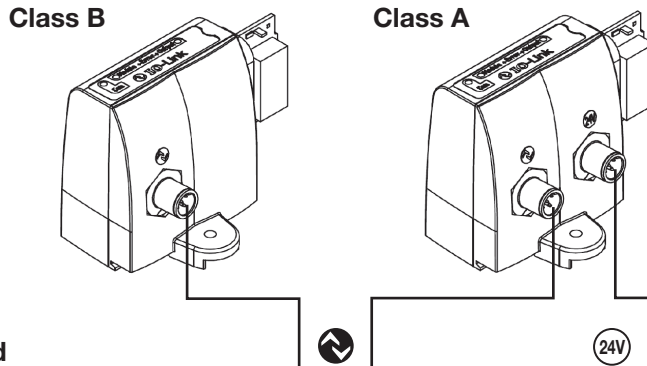

Legend

Symbol	Description
L+	IO-Link Power Supply "+"
L-	IO-Link Power Supply "-"
C/Q	IO-Link communication
Aux +	Auxiliary Power Supply 24 VDC
Aux -	Auxiliary Power Supply 0 VDC

M12 Pin's	Class A		
	3 Pin's	5 Pin's	
	P2M...A13	P2M...A43	P2M...A42
1	Aux +	Not used	Not used
2	-	-	Aux -
3	Aux -	Aux -	Not used
4	n.c.	Aux +	Aux +
5	-	-	Not used

Auxiliary Power Supply Compatibility

The Moduflex IO-Link Module can be powered from a 24VDC auxiliary source in PP or PM mode as grounds are isolated.

For compatibility with a safe output pulsed module, please refer to user manual document available on www.parker.com/pdn/io-link

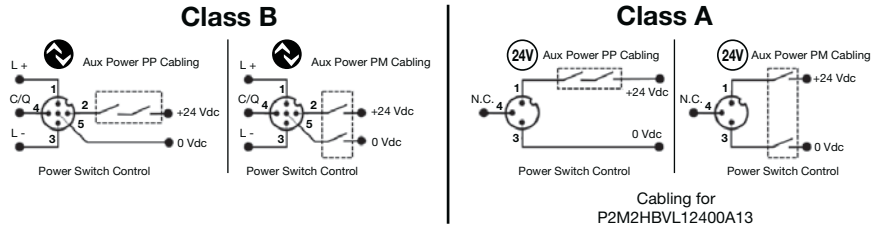

IO-Link module diagnostic functions

The Moduflex IO-Link module offers additional useful module status information:

- Solenoid overload or short circuit
- Auxiliary Voltage out of tolerance
- Cycle counter for each solenoid
- Module temperature

For more information on product technical information and module diagnostic functionalities, please refer to the User Manual available from the product web page:

www.parker.com/pdn/io-link

Green LED			Module – Error Red LED			Error – Output Red LED			Green LED		
LED Status	Description	Solving	LED Status	Description	Solving	LED Status	Description	Solving	LED Status	Description	Solving
OFF	IO-Link L+ / L- not powered	Check connection	OFF	Standard mode	NA	OFF	Standard mode	NA	OFF	AUX power failure	Check Auxiliary Power Supply
ON	IOL L+ / L- powered IO mode	Set IO-Link mode in IO-Link master	ON	24 VDC AUX power missing or any active malfunction	Check power supply or change module	ON	Any driver error (overload, over temperature, etc.)	Fix solenoid issue then acknowledge error	ON	Standard	NA
Blinking	IO-Link communication active	NA							Blinking	Aux Power is out of range, alarm level	Check Auxiliary Power Supply

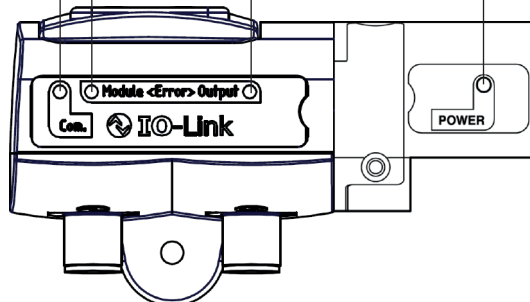

For inventory, lead time, and kit lookup, visit www.pdnplu.com

D139b

Parker Hannifin Corporation
 Pneumatic Division
 Richland, Michigan
www.parker.com/pneumatics

D

Subbase & Manual Valves

H Series Micro

Moduflex Series

H Series ISO

Fieldbus Systems

DX ISOMAX Series

Valvair II Series

Input Data

One byte of diagnostic input data is transferred from Moduflex to the IO-Link Master.

Process Input Data

7	6	5	4	3	2	1	0
Output Driver SPI Error	Output Driver Channel Error	Polyfuse Tripped	Temperature Warning	SPI Error	AUX Voltage Error	AUX Voltage Warning	Acknowledge Required

Output Data

Three bytes of process data are received by Moduflex from the IO-Link Master for control of solenoids.

Process Output Data (Byte 0)

7	6	5	4	3	2	1	0
EV8	EV7	EV6	EV5	EV4	EV3	EV2	EV1

Process Output Data (Byte 1)

7	6	5	4	3	2	1	0
EV16	EV15	EV14	EV13	EV12	EV11	EV10	EV9

Process Output Data (Byte 2)

7	6	5	4	3	2	1	0
EV24	EV23	EV22	EV21	EV20	EV19	EV18	EV17

Solenoid Pilots Addressing And Process Mapping

IO-Link Module addressing used with Moduflex Valve System

The Moduflex IO-Link module used with Moduflex Valve System can handle up to 19 pilot solenoid valves. Addressing will be done as shown below.

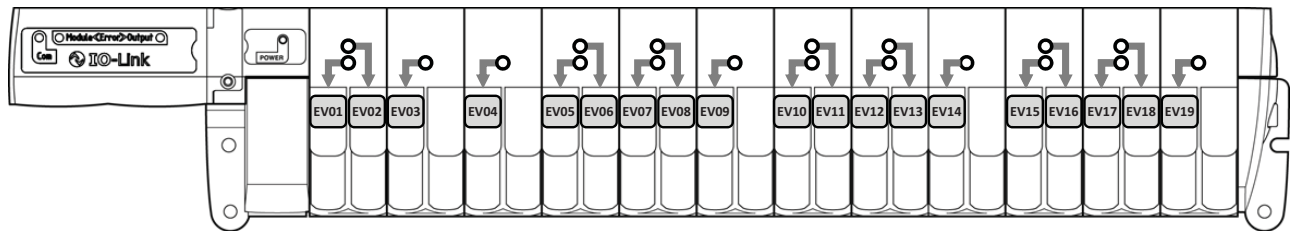

	7	6	5	4	3	2	1	0
PLC mapping Process output	Byte 0	EV08 EV01						
	Byte 1	EV16 EV09						
	Byte 2	EV24 EV17						

IO-Link Module Electrical Specifications

IO-Link Power Supply	According to IO-Link standard V1.1.2
Speed Communication	Com 2 – 38 kBd
Auxiliary Power Supply	20.4 VDC to 26.4 VDC
Current Limit per channel	150 mA
Max Current Limit	4 A
Polarity inversion	YES
Short Circuit Protection	YES
Operating Temperature	0°C to 55°C
Storage Temperature	-25°C to 70°C
Shock According to IEC	60068-2-27:2008
Vibration According to IEC	60068-2-6:2007
EMC According to IEC	61000-4-2 up to -4-6

Network diagnostic through Process mapping:

The Moduflex IO-Link module offers diagnostic data transmitted to the PLC through the master:

	7	6	5	4	3	2	1	0
PLC mapping Process input	Byte 0	Diag 7 Diag 0						

Diag bit	Error message	Detail
Diag 0.....	Fail-safe status	Acknowledgment required
Diag 1.....	Auxiliary voltage warning.....	Check auxiliary power
Diag 2.....	Auxiliary voltage failure.....	Check auxiliary power
Diag 3.....	Module failure	Module HS. must be replaced
Diag 4.....	Module over-temperature	
Diag 5.....	Module over-load	
Diag 6.....	Pilot Solenoid(s) short circuit	Solenoid must be replaced
Diag 7.....	Outputs stage failure	

For further details, refer to the User Manual: Can be downloaded from www.parker.com/pdn/io-link



For inventory, lead times, and kit lookup, visit www.pdnplu.com

D139c

Parker Hannifin Corporation
 Pneumatic Division
 Richland, Michigan
www.parker.com/pneumatics

D
 Subbase & Manual Valves
 H Series Micro
 Moduflex Series
 H Series ISO
 Fieldbus Systems
 DX ISOMAX Series
 Valvair II Series



P2M2HBVA10808A



P2M2HBVA10808B

Standard AS-i Protocol (up to 31 nodes)
Communication module for 8 solenoids max.
(2 nodes per module, 4 inputs, 4 solenoids per node)

Input / Output capability	Weight (oz)	Part number
0 inputs and 8 solenoid outputs	5.29	P2M2HBVA10800
8 (PNP) inputs on eight (M8) connectors and 8 solenoid outputs	7.05	P2M2HBVA10808A
8 (PNP) inputs on four (M12) connectors and 8 solenoid outputs	7.05	P2M2HBVA10808B

Fieldbus Accessories

	Protocol	Connector type	Part number
Power supply Field wireable connector	Profibus DP / InterBus-S / DeviceNet / CANopen	M12 type A female	P8CS1205AA
Line termination resistor	Profibus DP / DeviceNet / CANopen	M12 type B / M12 type A	P8BPA00MB / P8BPA00MA

AS-i Version 2.1 Protocol (up to 62 nodes)
Communication module for 6 solenoids max.
(2 nodes per module, 4 inputs, 3 solenoids per node)

Input / Output capability	Weight (oz)	Part number
0 inputs and 6 solenoid outputs	5.29	P2M2HBVA20600
8 (PNP) inputs on eight (M8) connectors and 6 solenoid outputs	7.05	P2M2HBVA20608A
8 (PNP) inputs on four (M12) connectors and 6 solenoid outputs	7.05	P2M2HBVA20608B

AS-i Bus Accessories

M12 Cable with Jack for Addressing

Length	Weight (oz)	Part number
1 m	3.53	P8LS12JACK

Most popular.

M12 (Male) Power Supply Connector

- 1 - 24VDC Module (Not Connected for DeviceNet and CANopen)
- 2 - Not Connected
- 3 - 0VDC Module and Solenoid
- 4 - 24VDC Solenoid
- 5 - Protected Earth (PE)

Profibus DP / DeviceNet / CANopen / InterBus-S

24VDC
 (As Seen On Module)

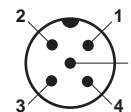

M12 Male Type A

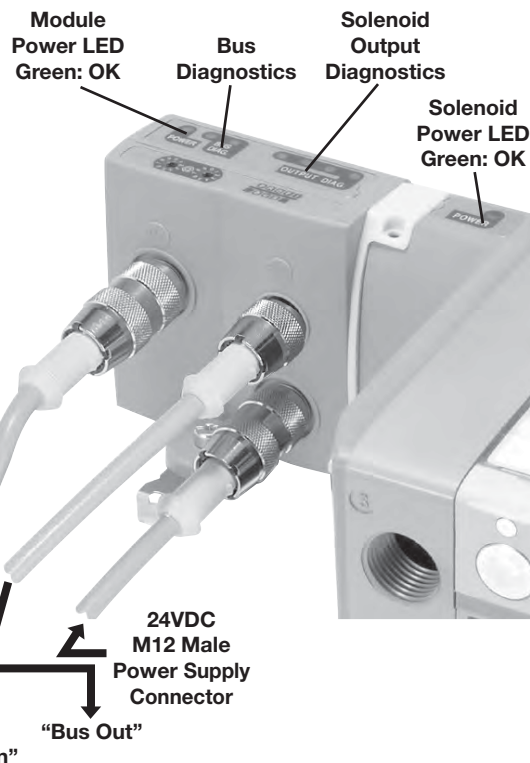

Connection

All communication modules have an M12 male connector for power supply.

Connector on Moduflex Modules are labeled. Bus Connectors are labeled "Bus In" and "Bus Out" while, Power Supply Connections are labeled "24VDC". Connect Fieldbus to "Bus In" and "Bus Out" and Power Supply to "24VDC".

Diagnostic

The two "power" indicators shown on the illustrations provide visual indication of the module and solenoid supply status.

Note: Output power to the solenoids can be wired to allow the user to turn the outputs off while allowing communications to remain on. This can be done by placing the user's Emergency Stop switch or other hard-wired control contact between Pin 1 and Pin 4. If this feature is not required, Pin 1 and Pin 4 should be wired together.

D

Subbase & Manual Valves

H Series Micro

Moduflex Series

H Series ISO

Fieldbus Systems

DX ISOMAX Series

Valvair II Series



For inventory, lead times, and kit lookup, visit www.pdnplu.com

Communication Module: Connections, Addressing, Diagnostic



Bus Cable Connections

Profibus DP standard male and female type B M12 connectors.

Line termination P8BPA00MB, is necessary on the “bus out” connector of the last station.

This module incorporates an Autobaud detect feature, eliminating the need to set switches.

Addressing

Use the GSD file on web site.

The rotary switches enable configuration of the decimal address.

Diagnostic

Diagnostic according to the module dialog shown on the illustration.

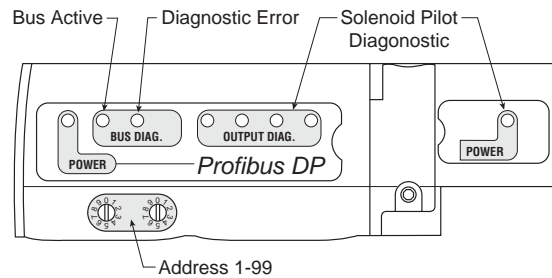
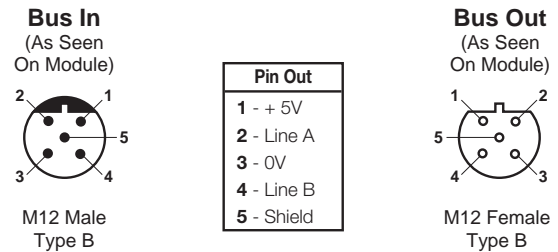

Bus Cable Connections

DeviceNet standard male and female type A M12 connectors.

Line termination P8BPA00MA, is necessary on the “bus out” connector of the last station.

Addressing

Use the EDS file on web site.

The rotary switches enable configuration of the node address (MAC ID) and the baud rate.

Diagnostic

Diagnostic according to the module dialog shown on the illustration.

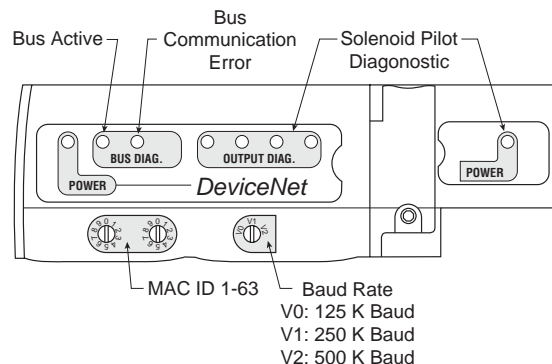
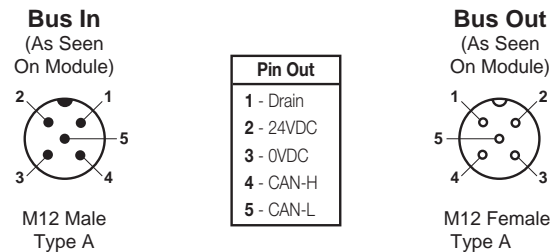

For inventory, lead time, and kit lookup, visit www.pdnplu.com

CANopen

Bus Cable Connections

CANopen standard male and female type A M12 connectors.

Line termination P8BPA00MA, is necessary on the “bus out” connector of the last station.

Addressing

Use the EDS file on web site.

The rotary switches enable configuration of the decimal address.

Diagnostic

Diagnostic according to the module dialog shown on the illustration.

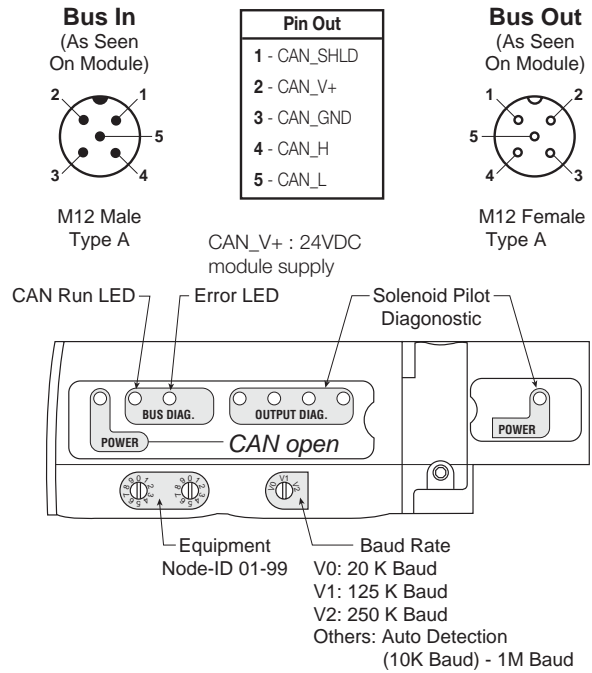

D
 Subbase & Manual Valves
 H Series Micro
 Moduflex Series
 H Series ISO
 Fieldbus Systems
 DX ISOMAX Series
 Valvair II Series

INTERBUS-S

Bus Cable Connections

The M23 connectors conform to “Interbus remote bus”.

This module operates at 500 kbps.

Addressing

InterBus-S is self addressing; therefore, it does not need any software or hardware configuration.

Diagnostic

Diagnostic according to the module dialog shown on the illustration.

This diagnostic conforms to the InterBus-S standard.

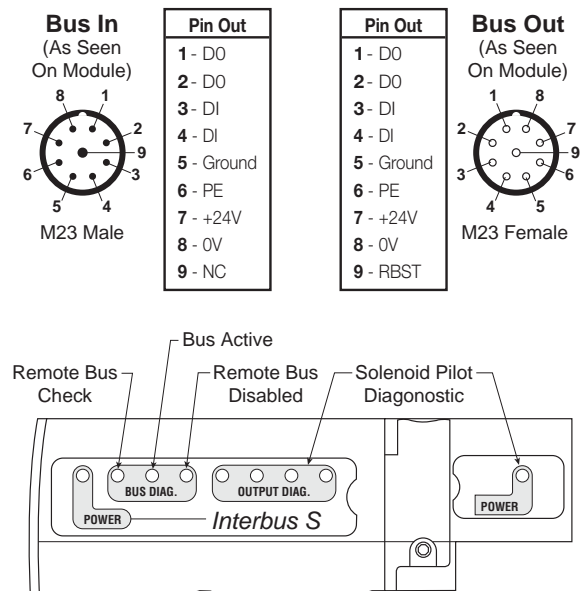

Note: For more details, please consult “Interbus remote bus” documentation.



For inventory, lead times, and kit lookup, visit www.pdnplu.com

AS-i Bus Communication Module: Addressing, Diagnostic, Input Wiring
Bus Addressing, First and Second Node

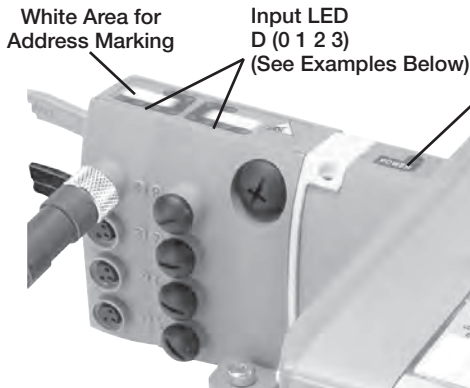
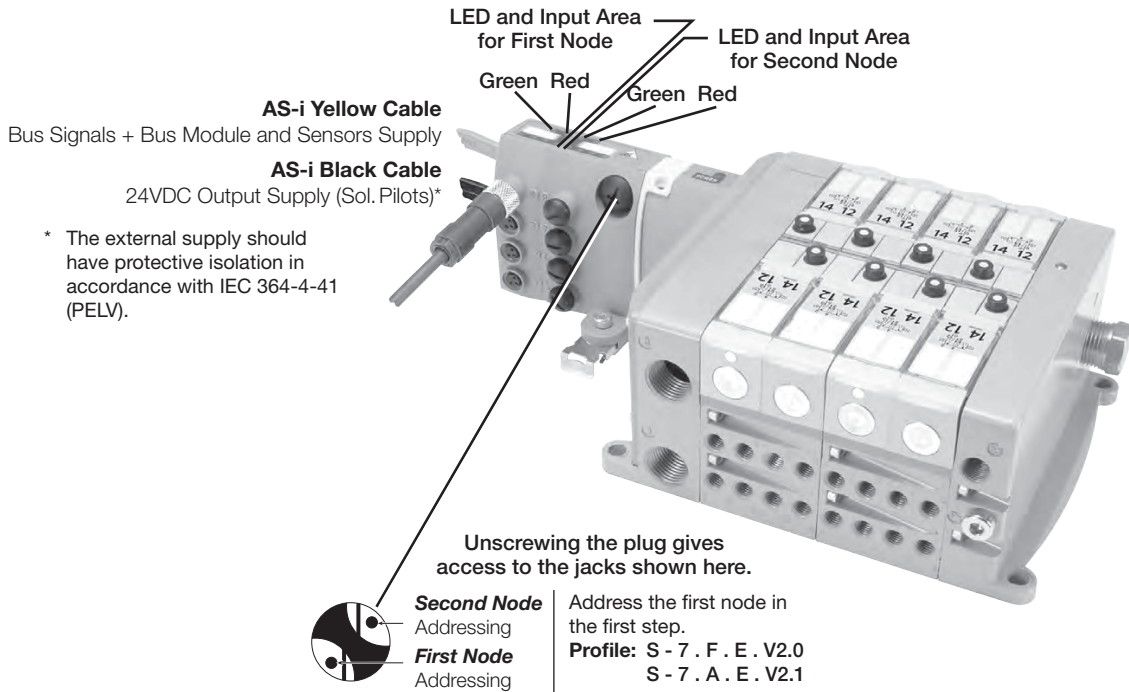

Bus Diagnostic

"Power" LED State		Off	Green	Red	
Power Supply		Sol. Pilot Supply	Normal Operation	Solenoid Overload	
First Node LEDs State		Second Node LEDs State		System Condition	
Green LED	Red LED	Green LED	Red LED		
★	○	★	○	Normal Operation	
○	○	○	○	No Module + Sensor Supply	
○	⚙	○	⚙	Input Overload	
○	★	○	⚙	No AS-i Communication	
⚙	★	○	⚙	Address First Node = 0	
★	○	⚙	★	Address Second Node = 0	

★ ON ○ OFF ⚙ BLINK

Input Wiring

Physical Input (I, II, III, IV) = D (0 1 2 3) First Node,
 Physical Input (V, VI, VII, VIII) = D (0 1 2 3) Second Node.

Examples: Physical Input III = Logical Input 6.2,
 Physical Input V = Logical Input 7.0.

M8 Female Connectors

Pin Out

- 1 - 24VDC / AS-i
- 3 - 0VDC / AS-i
- 4 - Input

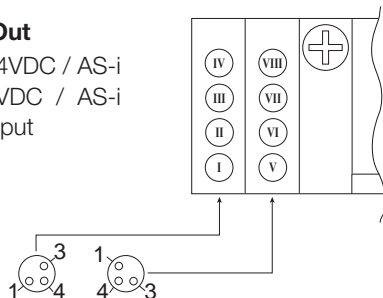

M12 Female Connectors

Pin Out

- 1 - 24VDC / AS-i
- 2 - Second Input
- 3 - 0VDC / AS-i
- 4 - First Input
- 5 - Not Connected

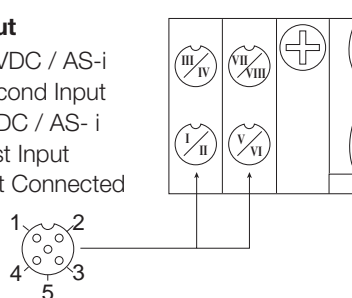

Note: With only one node, the inputs II and IV are connected to the connections on the right.



For inventory, lead time, and kit lookup, visit www.pdnplu.com

D143

Parker Hannifin Corporation
 Pneumatic Division
 Richland, Michigan
www.parker.com/pneumatics

D

Subbase & Manual Valves

H Series Micro

Moduflex Series

H Series ISO

Fieldbus Systems

DX ISOMAX Series

Valvair II Series

Solenoid Pilot Diagnostic Common to All Device Bus Modules

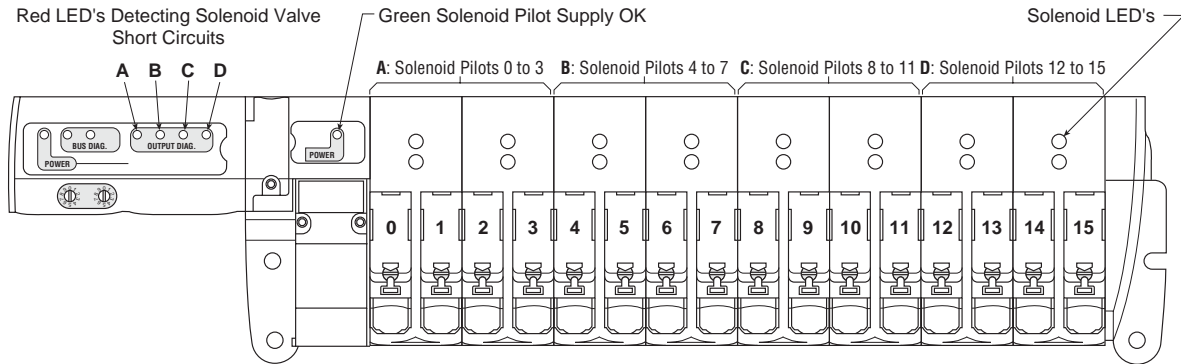

Inside the communication module, solenoid valve control is protected against short-circuits with the following visual indication provided:

- The red LEDs with code, shown above, detect solenoid valve short-circuits.
- Supply is OK when the solenoid pilot power supply indicator is green.

D
 Subbase & Manual Valves
 H Series Micro
 Moduflex Series
 H Series ISO
 Fieldbus Systems
 DX ISOMAX Series
 Valvair II Series

Bus Cable Protection

Shield Connections for Profibus DP, DeviceNet and CANopen

To provide protection against electro-magnetic interferences, the bus cables are shielded. The "bus in" and "bus out" connectors each include a pin for connecting the cable shield. It is safer to connect the shield to the protected earth (PE) at both ends of the bus. Within the communication module, provision is made to enable shield continuity by connecting the two shield pins.

The protected earth must be connected locally on each module for CE accordance.

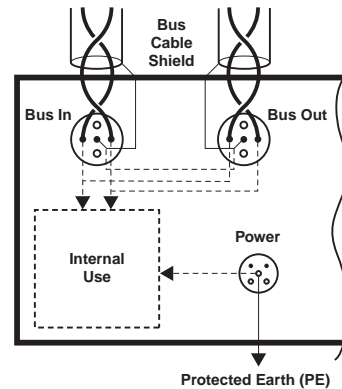

For inventory, lead times, and kit lookup, visit www.pdnplu.com

Solenoid Pilot Diagnostic Common to All Moduflex Fieldbus Modules

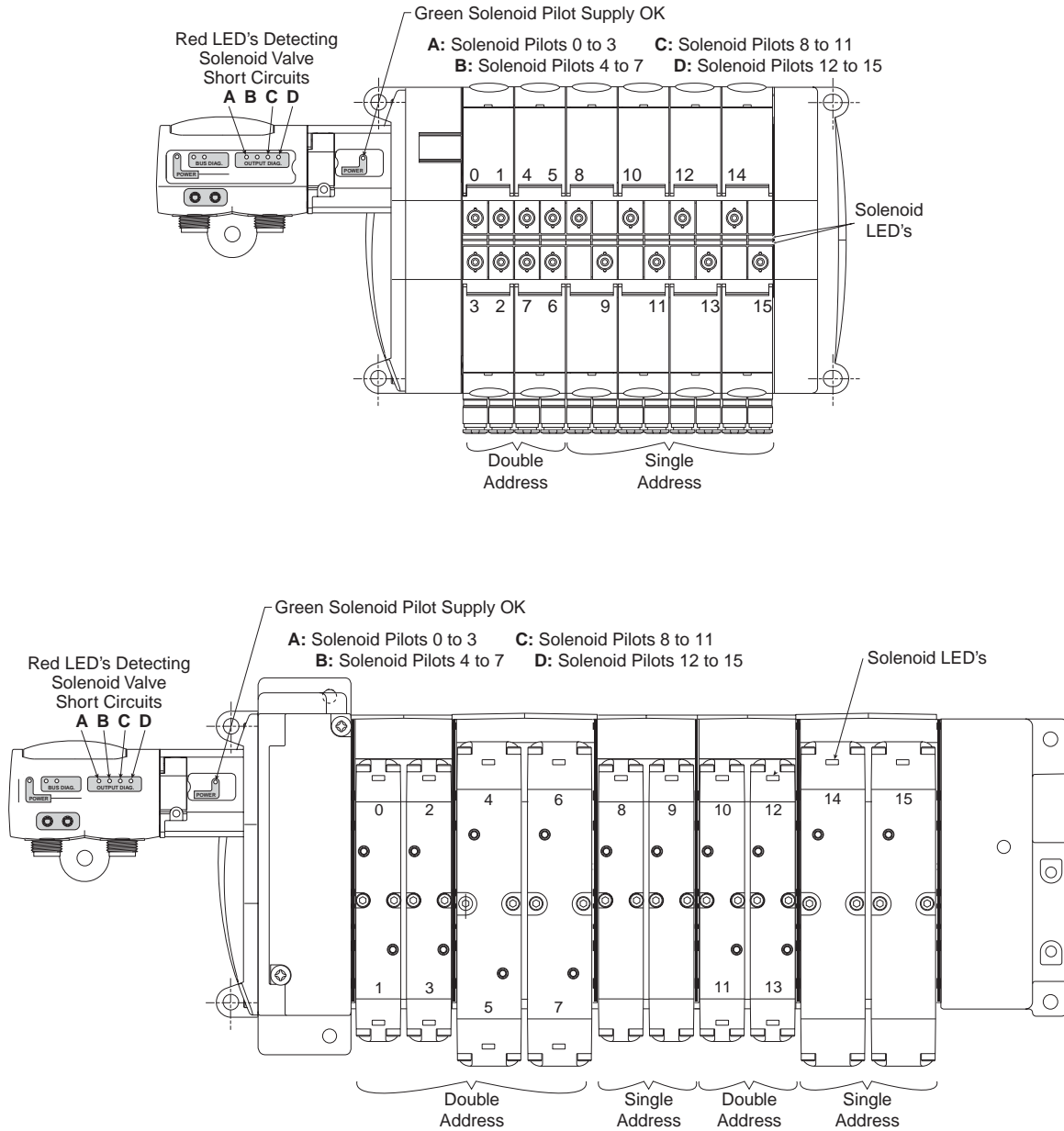

Inside the communication module, solenoid valve control is protected against short-circuits with the following visual indication provided:

- The red LEDs with code, shown above, detect solenoid valve short-circuits.
- Supply is OK when the solenoid pilot power supply indicator is green.



For inventory, lead time, and kit lookup, visit www.pdnplu.com

D145

Parker Hannifin Corporation
 Pneumatic Division
 Richland, Michigan
www.parker.com/pneumatics

D

Subbase & Manual Valves

H Series Micro

Moduflex Series

H Series ISO

Fieldbus Systems

DX ISOMAX Series

Valvair II Series

Serial Bus Specifications

All Buses	EMC / CE Mark	According to EN 61 000-6-2	EN 50081-2
AS-i Bus	AS-i Line	According to EN 50295	
	Solenoid Pilot Voltage	24VDC	
	Module Consumption	max. 70 mA (2 nodes)	
	Max. Supply for All Inputs	240 mA (including internal input consumption)	
	Internal Input Consump.	9 mA for each active input	
	Inputs	According to IEC 1131-2 class 2	
	Certification	These products have been developed according to the association complete specification (v.2.11) and to the slave profiles S-7.FE or S-B.FE	
	Bus Line	According to each bus specification	
	Module Voltage	20 to 30VDC	
	Solenoid Pilot Voltage	24VDC	
Device Bus	Module Consumption	Profibus DP max. 1.5W	DeviceNet / CANopen max. 1.5W InterBus-S max. 2W
	Outputs	Overload protection	
	Certification	DeviceNet: Compliant to Composite Test Revision 17, Test Suite: M002	
		Profibus-DP: Compliant to Test Specifications for Profibus DP Slaves, Version 2.0, February 2000, based on EN 50170-2 at Siemens AG in Furth.	
		InterBus-S: This product has passed the relevant tests in accordance with the Interbus conformance requirements Certified No. 385.	

I/O Tables Common to All Device Bus Modules

Input Data Table

Byte	Bit 0	Bit 1	Bit 2	Bit 3	Bit 4	Bit 5	Bit 6	Bit 7
0	Discrete Input 0 (Diagnostic LED 0-3)	Discrete Input 1 (Diagnostic LED 4-7)	Discrete Input 2 (Diagnostic LED 8-11)	Discrete Input 3 (Diagnostic LED 12-15)	—	—	—	—

Output Data Table

Byte	Bit 0	Bit 1	Bit 2	Bit 3	Bit 4	Bit 5	Bit 6	Bit 7
0	Discrete Output 0	Discrete Output 1	Discrete Output 2	Discrete Output 3	Discrete Output 4	Discrete Output 5	Discrete Output 6	Discrete Output 7
1	Discrete Output 8	Discrete Output 9	Discrete Output 10	Discrete Output 11	Discrete Output 12	Discrete Output 13	Discrete Output 14	Discrete Output 15

D
 Subbase & Manual Valves
 H Series Micro
 Moduflex Series
 H Series ISO
 Fieldbus Systems
 DX ISOMAX Series
 Valvair II Series



For inventory, lead times, and kit lookup, visit www.pdnplu.com

H Series ISO & H Series Fieldbus System

- A complete fieldbus communication offering for all H Series ISO and H Series Micro valves.
- CSA, C-US and CE certifications (as marked).

I/O Configuration

- Centralized H Series Fieldbus system.
- Pneumatics and I/O are in close proximity to one another.
- I/O density per module = 8 or 16.

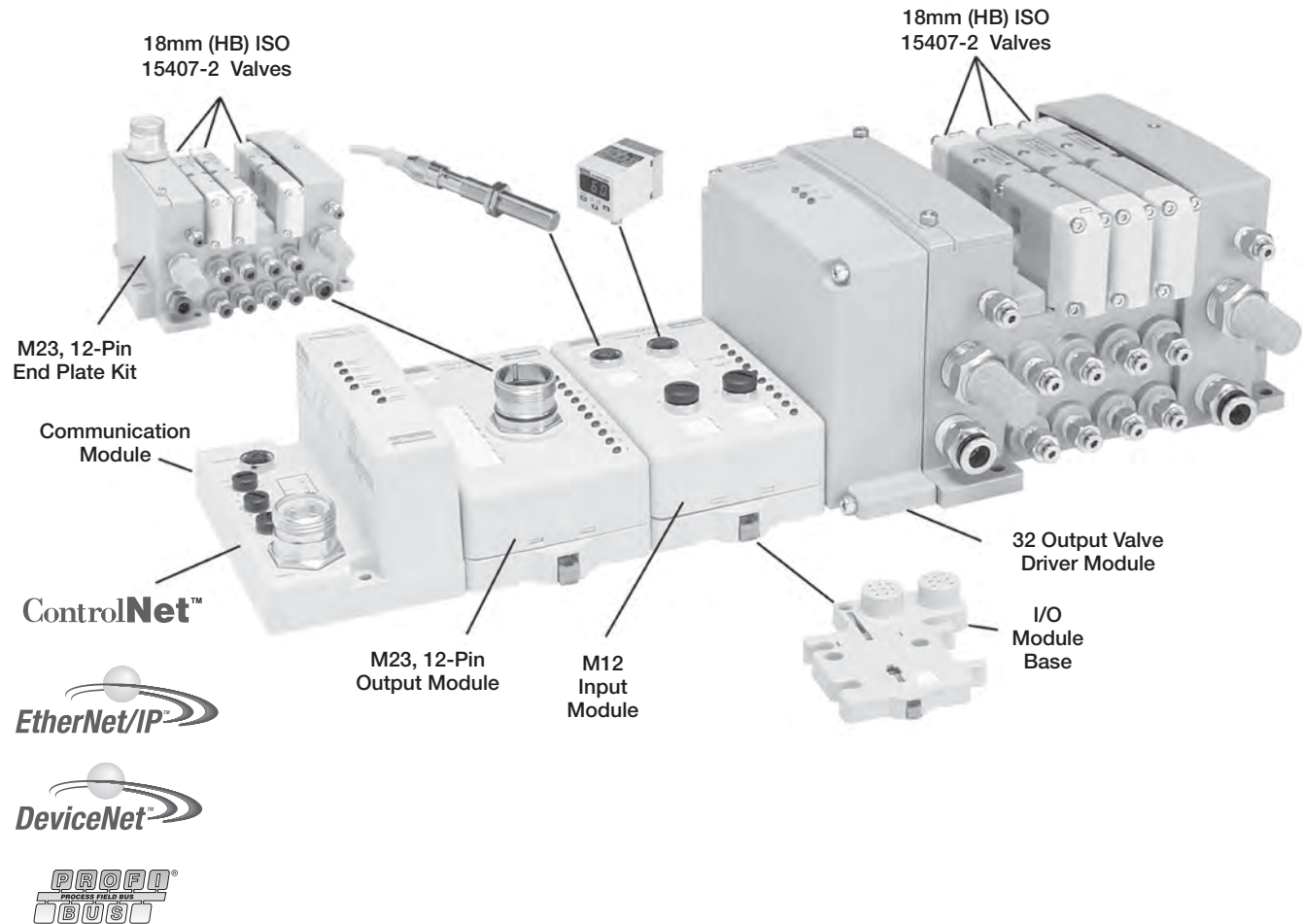

D	Subbase & Manual Valves
H Series Micro	H Series ISO
Fieldbus Systems	Moduflex Series
DX ISOMAX Series	Valvair II Series

H Series ISO & H Series Fieldbus System

- A complete fieldbus communication offering for all H Series ISO and H Series Micro valves.
- CSA, C-US and CE certifications (as marked).

I/O Configuration

- Decentralized H Series Fieldbus system.
- Pneumatics and I/O are not in close proximity with one another.
- M23, 12-Pin or 19-Pin output extension to an H Series ISO valve island.
- 25-Pin, D-Sub output extension to an H Series ISO valve island.
- I/O density per module = 8 or 16.

D	Subbase & Manual Valves
	H Series Micro
	Modutlex Series
	H Series ISO
	Fieldbus Systems
	DX ISOMAX Series
	Valvair II Series

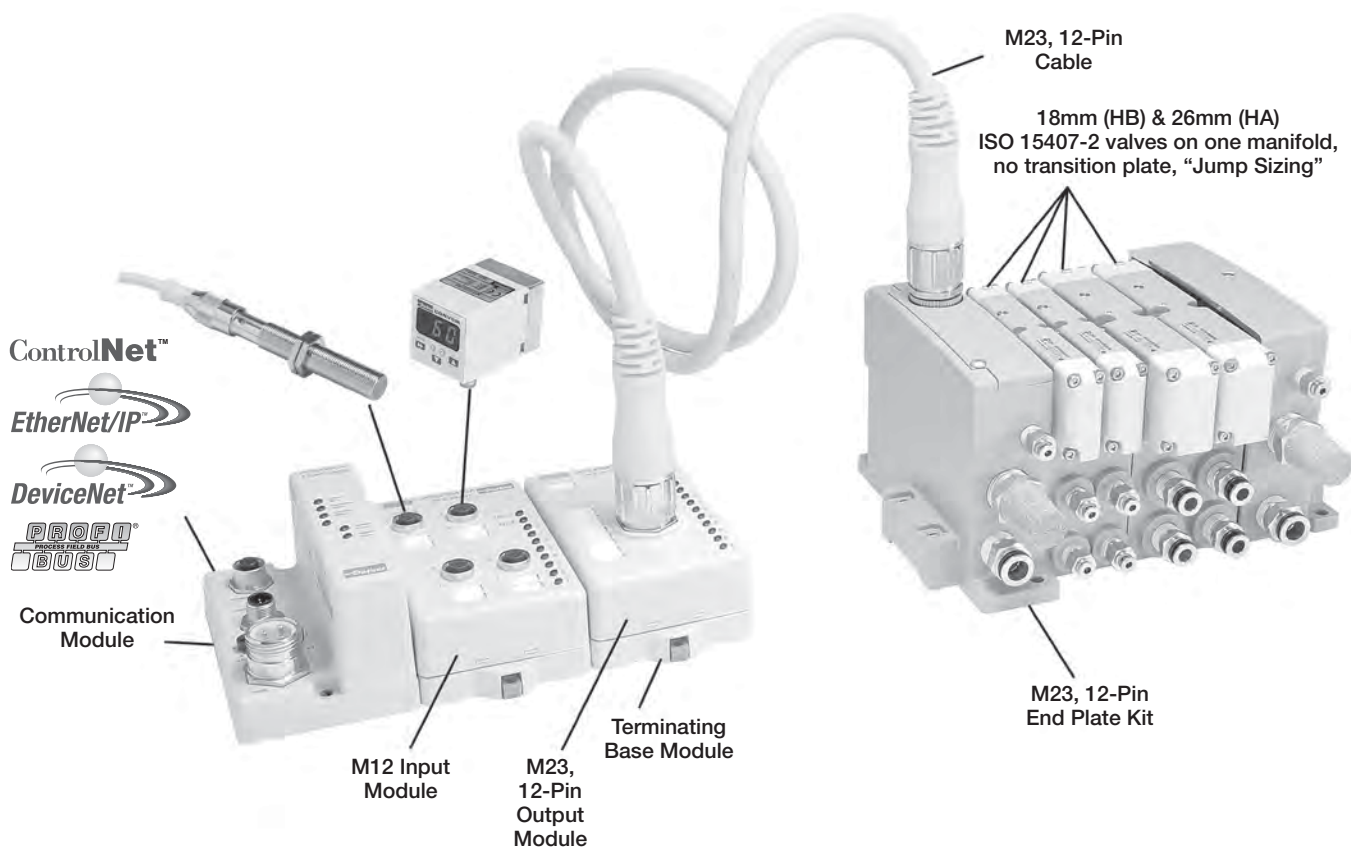

For inventory, lead times, and kit lookup, visit www.pdnplu.com

D148

Parker Hannifin Corporation
 Pneumatic Division
 Richland, Michigan
www.parker.com/pneumatics

H Series ISO & H Series Fieldbus System

- A complete fieldbus communication offering for all H Series ISO and H Series Micro valves.
- CSA, C-US and CE certifications (as marked).

I/O Configuration

- Decentralized H Series Fieldbus system.
- Pneumatics and I/O are not in close proximity with one another.
- M23, 12-Pin or 19-Pin output extension to an H Series ISO valve island.
- Separate output and input clusters using a bus extender cable.
- Separate output and input power using a power extension module.
- 25-Pin, D-Sub output extension to an H Series ISO valve island.
- I/O density per module = 8 or 16.

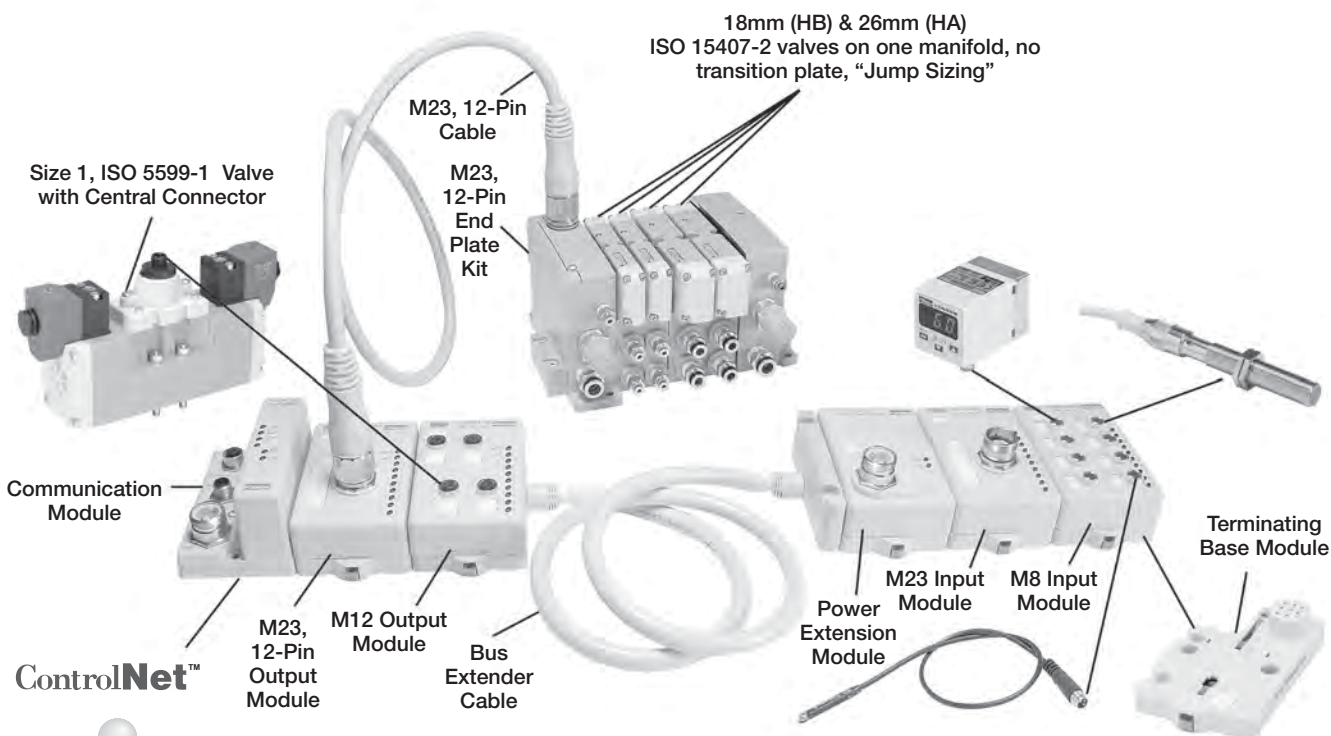

ControlNet™

EtherNet/IP™

DeviceNet™

PROFIBUS
 PROCESS FIELD BUS

D	Subbase & Manual Valves
H Series Micro	H Series ISO
Fieldbus Systems	DX ISOMAX Series
Valvair II Series	



For inventory, lead time, and kit lookup, visit www.pdnplu.com

Features

The H Series Fieldbus System

H Series Fieldbus has four major components:

- Valve driver module provide control for 32 solenoids on a manifold, with bus extension providing connectivity to 3 more manifolds
- I/O modules provide the field interface, system-interface circuitry, and bases for mounting
- Communication modules provide the network-interface circuitry
- Power distribution module provide 5 additional power inputs to the H Series Fieldbus system

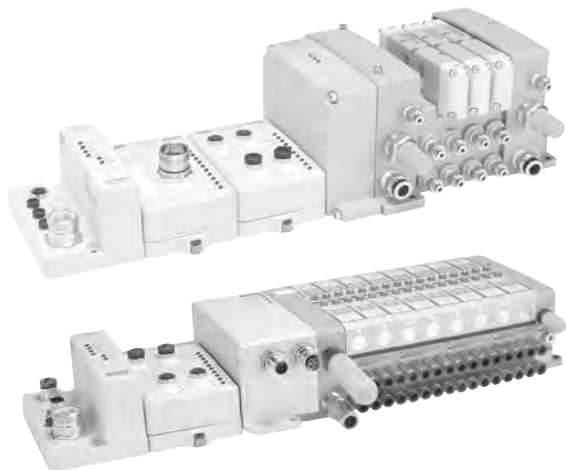

Subbase & Manifold Valve Products H Series Fieldbus System

H Series Fieldbus Features

- Highly modular design (4pt – 16pt modularity)
- Broad application coverage
- Channel-level diagnostics (LED)
- Channel-level alarm and annunciation (electronic)
- Channel-level open-wire detection with electronic feedback
- Parameter-level explicit messaging
- Horizontal and vertical mounting without derating
- 5g vibration
- Electronic and mechanical keying
- Robust backplane design
- Quick-disconnects for I/O and network connectivity
- Built-in panel grounding
- Color-coded module labels
- UL, C-UL, and CE certifications (as marked)
- Highly reliable structural integrity
- Optical isolation between field and system circuits

D

Subbase & Manual
Valves

Communications Module



Protocol	Part number
DeviceNet™	PSSCDM18PA (7/8" Mini) or PSSCDM12A (M12)
ControlNet™	PSSCCNA
Ethernet I/P™	PSSCENA
Profibus-DP®	PSSCPBA

PSSCENA

All Modules IP67 Certified
Reference the following documents for installation instructions.
DeviceNet - E101P, PSS-UM001A; Control Net - E103P
Ethernet I/P - E104P; Profibus-DP - E102P

H Series
Micro

Moduteflex
Series

Digital Inputs



PSSN16M12A



PSSN8M8A

I/O modules	Voltage	Part number
16 digital inputs M12, 5-pin used with PNP sourcing input device	10 to 28.8VDC	PSSN16M12A
8 digital inputs M12, 5-pin used with PNP sourcing input device	10 to 28.8VDC	PSSN8M12A
8 digital inputs M12, 5-pin used with NPN sinking input device	10 to 28.8VDC	PSSP8M12A
8 digital inputs M8, 3-pin used with PNP sourcing input device	10 to 28.8VDC	PSSN8M8A
8 digital inputs M23, 12-pin used with PNP sourcing input device	10 to 28.8VDC	PSSN8M23A

H Series
ISO

Fieldbus
Systems

DX ISOMAX
Series

Reference E106P document for installation instructions.

Most popular.





For inventory, lead times, and kit lookup, visit www.pdnplu.com

D150

Parker Hannifin Corporation
Pneumatic Division
Richland, Michigan
www.parker.com/pneumatics

Valvair II
Series

Digital Outputs

	I/O modules	Voltage	Part number
 PSST16D25A	16 digital outputs M23, 19-pin used with PNP sourcing outputs*	10 to 28.8VDC	PSST16M23A
	16 digital outputs D-sub, 25-pin used with PNP sourcing outputs*	10 to 28.8VDC	PSST16D25A
	16 digital outputs M12, 5-pin used with PNP sourcing outputs*	10 to 28.8VDC	PSST16M12A
 PSST16M12A	8 digital outputs M12, 5-pin used with PNP sourcing outputs*	10 to 28.8VDC	PSST8M12A
	8 digital outputs M8, 3-pin used with PNP sourcing outputs*	10 to 28.8VDC	PSST8M8A
 PSSTR4M12A	4 digital output, high watt relay M12, 5-pin used with PNP sourcing outputs (2 Amp) [§]	24VDC	PSSTR4M12A
	8 digital outputs M23, 12-pin used with PNP sourcing outputs*	10 to 28.8VDC	PSST8M23A

All modules IP67 certified
Reference the following documents for installation instructions.
⁺ E107P
[§] E109P
 See www.pdnplu.com

Analog Inputs

	I/O modules	Voltage	Part number
 PSSNACM12A	2 Analog inputs voltage M12, 5-pin [†]	-10 to 10VDC or 0 to 10VDC	PSSNAVM12A
	2 Analog inputs current M12, 5-pin [†]	4 to 20mA or 0 to 20mA	PSSNACM12A

All modules IP67 certified
[†] Reference E110P document for installation instructions.
 See www.pdnplu.com

Analog Outputs

	I/O modules	Voltage	Part number
 PSSTACM12A	2 Analog outputs voltage M12, 5-pin**	0 to 10V ± 10V	PSSTAVM12A
	2 Analog outputs current M12, 5-pin**	4 to 20mA or 0 to 20mA	PSSTACM12A

All modules IP67 certified
^{**} Reference E111P document for installation instructions.
 See www.pdnplu.com

Terminating Base Module

	Base module	Part number
 PSSTERM	Termination base for stand alone units	PSSTERM

Used as the last terminating module for a stand alone H Series Fieldbus assembly.

 Most popular.



For inventory, lead time, and kit lookup, visit www.pdnplu.com

Power Extender Module

	Extender module	Part number
	24VDC field power module	PSSSE24A

A Power Extender Module must be used on every 14th module in H Series Fieldbus assembly.
 Reference document E105P and PSS-SG001 for configuration instructions.
 See www.pdnplu.com

Bus Extender Cable

	Description	Voltage	Part number
	1 Meter Cable*	24VDC	PSSEXT1
	3 Meter Cable*	24VDC	PSSEXT3

* Requires a PSSSE24 Power Extender Module
 IP67 certified
 Reference E117P document for installation instructions.
 See www.pdnplu.com

H Series Micro Bus Extender Cable

	Description	Voltage	Part number
	1 Meter Cable*	24VDC	PSSVEXT1

* IP67 certified.

Replacement Base Module

	Description	Part number
	Base Module	PSSBASE

D

Subbase & Manual Valves

H Series Micro

Modulflex Series

H Series ISO

Fieldbus Systems

DX ISOMAX Series

Valvair II Series

 Most popular.



For inventory, lead times, and kit lookup, visit www.pdnplu.com

Using Bus Extender Cables

Example #1:

H Series ISO with Standard Bus Extender Cable

- Separate the communication module and a portion of the I/O from other I/O and the valve manifold.
- Commonly used when overall length is restricted.
- PSSSE24A is needed on the extension. No 24VDC connector needed on the H Series Fieldbus end plate.
- Can be used with H Series ISO and H Series Micro valves.



Example #2:

H Series Micro with Bus Extension on Valve Driver Module – No additional I/O at the Extension

- Add up to three additional valve manifolds without adding another communication module.
- No PSSSE24A is needed on the Extension when the Valve Driver Module with 24VDC Connector is used.
- Commonly used when many valves are required.
- Bus expansion only available with H Series Micro valves.

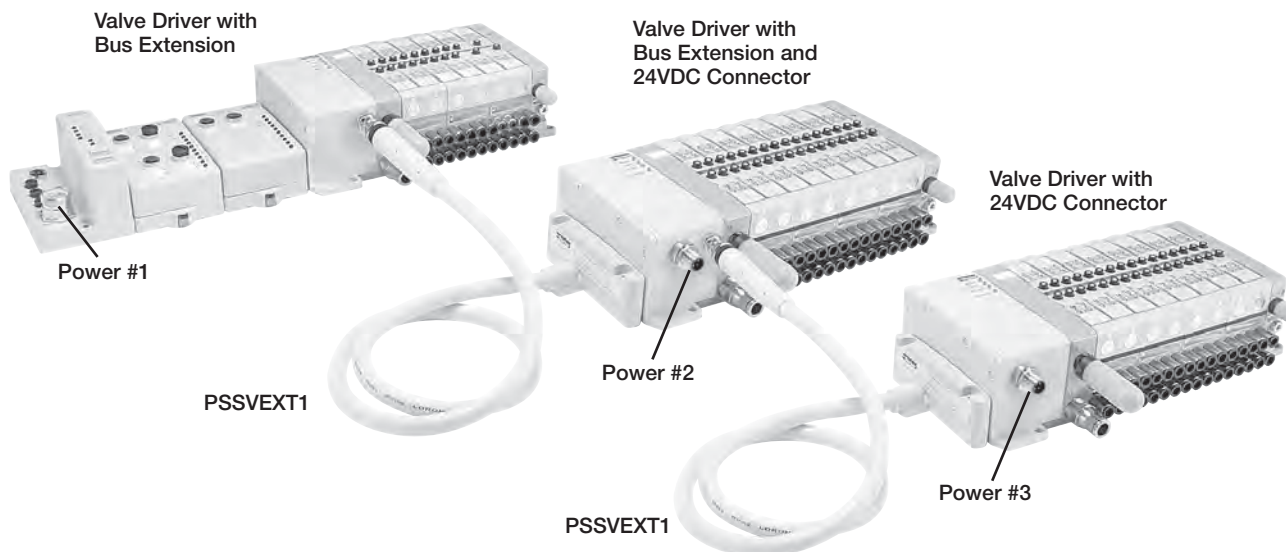

D
Subbase & Manual Valves
H Series Micro
Moduflex Series
H Series ISO
Fieldbus Systems
DX ISOMAX Series
Valvair II Series



For inventory, lead time, and kit lookup, visit www.pdnplu.com

Using Bus Extender Cables (continued)

Example #3:

H Series Micro with Bus Extension on Valve Driver – With I/O at Extension

- Add up to three additional valve manifolds without adding another communication module.
- PSSSE24A is needed on the Extension. No 24VDC Connector needed on the H Series Fieldbus end plate.
- Commonly used when many valves are required, and each location requires additional I/O.
- Bus expansion only available with H Series Micro.

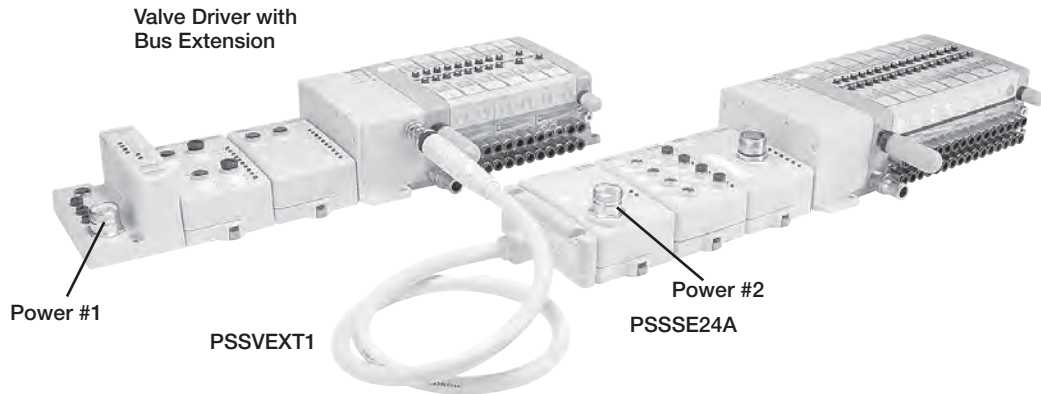

Example #4:

H Series Micro with Bus Extension on Valve Driver Module – With I/O at the Extension and larger H Series ISO Valve Manifold

- Add up to two additional H Series Micro valve manifolds and one H Series ISO valve manifold without adding another communication module.
- PSSSE24A is needed on the Extension.
- H Series ISO valve manifold must be the last manifold on the Extension
- Commonly used when many valves are required, and each location requires additional I/O.
- Bus expansion only available with H Series Micro. H Series ISO manifold must be the last manifold in the system.

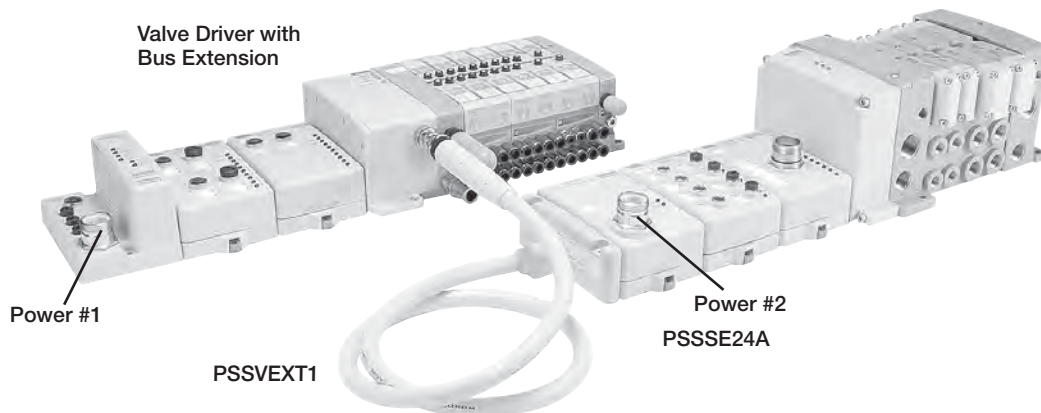

D	Subbase & Manual
Valves	H Series Micro
Modulflex Series	H Series ISO
Fieldbus Systems	DX ISOMAX Series
Valvair II Series	



For inventory, lead times, and kit lookup, visit www.pdnplu.com

Digital I/O Modules

Choose digital I/O modules when you need:

- **Input Modules.** An input module responds to an input signal in the following manner:
 - Input filtering limits the effect of voltage transients caused by contact bounce and/or electrical noise. If not filtered, voltage transients could produce false data. All input modules use input filtering.
 - Optical isolation shields logic circuits from possible damage due to electrical transients.
 - Logic circuits process the signal.
 - An input LED turns on or off indicating the status of the corresponding input device.
- **Output Modules.** An output module controls the output signal in the following manner:
 - Logic circuits determine the output status.
 - An output LED indicates the status of the output signal.
 - Optical isolation separates module logic and bus circuits from field power.
 - The output driver turns the corresponding output on or off.
- **Surge Suppression.** Most output modules have built-in surge suppression to reduce the effects of high-voltage transients. However, we recommend that you use an additional suppression device if an output is being used to control inductive devices, such as:
 - Relays
 - Motor starters
 - Solenoids
 - Motors

Additional suppression is especially important if your inductive device is in series with, or parallel to, hard contacts such as:

 - Push buttons
 - Selector switches

The digital I/O modules support:

- A wide variety of voltage interface capabilities
- Isolated and non-isolated module types
- Point-level output fault states
- Choice of direct-connect or rack-optimized communications
- Field-side diagnostics on select modules

Connector types are indicated by the catalog number. For example, the PSSN8M12A has an M12 connector.

Digital DC Input Modules

	PSSN8M8A PSSN8M12A PSSN8M23A	PSSN16M12A	PSSP8M12A
Number of Inputs	8 PNP Sourcing	16 PNP Sourcing	8 NPN Sinking
Keyswitch Position	1		
Voltage, On-State Input, Nom.	24VDC		
Voltage, On-State Input, Min.	10VDC		
Voltage, On-State Input, Max.	28.8VDC		
Input Delay Time, ON to OFF	0.5 ms hardware + (0...65 ms selectable)*		
Current, On-State Input, Min.	2 mA		
Current, On-State Input, Max.	5 mA		
Current, Off-State Input, Max.	1.5 mA		
Bus Power Current (mA)	75		
Power Dissipation, Max.	1.0 W @ 28.8VDC		

* Input ON-to-OFF delay time is the time from a valid input signal to recognition by the module.

Digital DC Output Modules

	PSST8M8A PSST8M12A PSST8M23A	PSST16M223A PSST16D25A PSST16M12A
Number of Outputs	8 PNP sourcing	16 PNP Sourcing
Keyswitch Position	1	
Voltage, On-State Output, Nom.	24VDC	
Voltage, On-State Output, Min.	10VDC	
Voltage, On-State Output, Max.	28.8VDC	
Output Current Rating, Max.	3.0 A per module, 1.0 A per channel	
Bus Power Current (mA)	75	
Power Dissipation, Max.	1.2 W @ 28.8VDC	

Relay Output Module

	PSSTR4M12A
Number of Outputs	4 Form A (N.O.) relays, isolated
Key switch Position	7
Output Delay Time, ON to OFF, Max.	26 ms*
Contact Resistance, Initial	30 mΩ
Current Leakage, Off-State Output, Max.	1.2 mA and bleed resistor thru snubber circuit @ 240V ac
Output Current Rating, Max	8.0 A per module, 2.0 A per channel
Bus Power Current (mA)	90
Power Dissipation, Max.	0.5 W

*Time from valid output off signal to relay de-energization by module.



For inventory, lead time, and kit lookup, visit www.pdnplu.com

Analog I/O Modules

The H Series Fieldbus analog modules support: on-board, channel-level data alarming (four set-points per channel); scaling to engineering units; channel-level diagnostics (electronic bits and LEDs); and integer format.

Choose analog I/O modules when you need:

- **Individually configurable channels** to use the module(s) with a variety of sensors.
- **On-board scaling** to eliminate the need to scale the data in the controller. Controller processing time and power are preserved for more important tasks, such as I/O control, communications, or other user-driven functions.
- **On-line configuration.** Modules can be configured in the RUN mode using the programming software or the control program. This allows you to change configuration while the system is operating. For example, the input filter for a particular channel could be changed, or a channel could be disabled based on a batch condition. To use this feature, the controller and network interface must also support this feature.
- **Over- and under-range detections and indications.** This eliminates the need to test values in the control program, saving valuable processing power of the controller. In addition, since alarms are handled by the module, the response is faster and only a single bit per channel is monitored to determine if an error condition has occurred.

- **Ability to direct output device operation during an abnormal condition.** Each channel of the output module can be individually configured to hold its last value or assume a user-defined value on a fault condition. This feature allows you to set the condition of your analog devices, and therefore your control process, which may help to ensure a reliable shutdown.
- **Ability to individually enable and disable channels.** Disabling unused channels improves module performance.
- **Selectable input filters** This lets you select the filter frequencies for each channel that best meets the performance needs of your application based on environmental limitations. Lower filter settings provide greater noise rejection and resolution. Higher filter settings provide faster performance. Note: The analog modules provide four input filter selections.
- **Selectable response to broken input sensor.** This feature provides feedback to the controller that a field device is not connected or operating properly. This lets you specify corrective action based on the bit or channel condition.
- **High accuracy.** The modules share a high accuracy rating of ±0.1% of full-scale accuracy at 25 °C.

Analog Input Modules

	PSSNACM12A	PSSNAVM12A
Number of inputs	2	2
Key switch position	3	3
Input signal range	4...20 mA 0...20 mA	-10 to 10VDC 0 to 10VDC
Input resolution, bits	16 bits - over 21 mA 0.32 µA/cnt	15 bits plus sign 320 µV/cnt in unipolar or bipolar mode
Absolute accuracy, current input	0.1% Full Scale @ 25°C*†	—
Absolute accuracy, voltage input	—	0.1% Full Scale @ 25°C*†
Input step response, per channel	70 ms @ Notch = 60 Hz (default) 80 ms @ Notch = 50 Hz 16 ms @ Notch = 250 Hz 8 ms @ Notch = 500 Hz	70 ms @ Notch = 60 Hz (default) 80 ms @ Notch = 50 Hz 16 ms @ Notch = 250 Hz 8 ms @ Notch = 500 Hz
Input conversion type	Delta Sigma	Delta Sigma
Bus power current (mA)	75	75
Power dissipation, max.	0.6 W @ 28.8VDC	0.6 W @ 28.8VDC

* Includes offset, gain, non-linearity and repeatability error terms.

† Analog input modules support these configurable parameters and diagnostics: open-wire with LED and electronic reporting; four-alarm and annunciation set-points; calibration mode and electronic reporting; under and over-range and electronic reporting; channel signal range and update rate and on-board scaling; filter-type; channel update rate.

Analog Output Modules

	PSSTACM12A	PSSTAVM12A
Number of outputs	2	2
Key switch position	4	4
Output signal range	4...20 mA 0...20 mA	-10 to 10VDC 0 to 10VDC
Output resolution, bits	13 bits - over 21 mA 2.5 µA/cnt	14 bits (13 plus sign) 1.28 mV/cnt in unipolar or bipolar mode
Absolute accuracy, current output	0.1% Full Scale @ 25°C*†	—
Absolute accuracy, voltage output	—	0.1% Full Scale @ 25°C*†
Step response to 63% of FS,	24 µs	— Current Output
Step response to 63% of FS,	—	20 µs Voltage Output
Output conversion rate	16 µs	20 µs
Bus power current (mA)	75	75
Power dissipation, max.	1.0 W @ 28.8VDC	1.0 W @ 28.8VDC

* Includes offset, gain, non-linearity and repeatability error terms.

† Analog output modules support these configurable parameters and diagnostics: open-wire with LED and electronic reporting (PSSTACM12A only); fault mode; idle mode; alarms; channel signal range and on-board scaling.

D

Subbase & Manual
Valves

H Series
Micro

Modulflex
Series

H Series
ISO

Fieldbus
Systems

DX ISOMAX
Series

Valvair II
Series



For inventory, lead times, and kit lookup, visit www.pdnplu.com

Valve Driver Modules

The PSSV32A and PSSVM32A valve driver modules provide an interface between the H Series Fieldbus serial bus system and the valve assembly. These modules will always be the last on the H Series Fieldbus serial bus, and control 32 digital outputs at 24VDC. Depending on the valve selection, a valve driver module can control up to 32 single solenoid valves or 16 double solenoid valves.

PSSV32A is used with H Series ISO valves and PSSVM32A is used with H Series Micro valves.

Specifications

	PSSV32A and PSSVM32A
Outputs per Module	32, PNP sourcing
Voltage Drop, On-State Output, Maximum	0.2VDC
Voltage, Off-State Output, Maximum	28.8VDC
Voltage, On-State Output, Maximum	28.8VDC
Minimum	10VDC
Nominal	24VDC
Output Current Rating	200 mA per channel, not to exceed 6.0 A per module
Output Surge Current, Maximum	0.5 A for 10 ms, repeatable every 3 seconds
Current Leakage, Off-State Output, Maximum	0.1 mA
Current, On-State Output Minimum	200 mA per channel
Output Delay Time OFF to ON, Maximum ¹	0.1 ms
Output Delay Time, ON to OFF, Maximum ¹	0.1 ms
External DC Power Supply Voltage Range	10 to 28.8VDC
External DC Power Supply Voltage Nominal	24VDC

1. OFF to ON or ON to OFF delay is time from a valid output "on" or "off" signal to output energization or de-energization.

Select the Appropriate Power Supply

Part number	Power supply Input voltage, Nom.	Operating Voltage range	Maximum continuous current draw	Power supply Inrush current, Max.	Input Overvoltage Protection	Power supply Interruption Protection
PSSCDM12A	24VDC	10...28.8VDC	10 A	6 A for 10 ms	Reverse polarity protected	Output voltage will stay within specifications when input drops out for max. load.
PSSCDM18PA						
PSSCCNA						
PSSCENA						
PSSCPBA						
PSSSE24A						

D

Subbase & Manual Valves

H Series Micro

Modulflex Series

H Series ISO

Fieldbus Systems

DX ISOMAX Series

Valvair II Series



For inventory, lead time, and kit lookup, visit www.pdnplu.com

Power Extender Module

The PSSSE24A expansion power unit passes 24VDC field power to the I/O modules to the right of it. This unit extends the backplane bus power and creates a new field voltage partition segment for driving field devices for up to 13 I/O modules. The expansion power unit separates field power from I/O modules to the left of the unit, effectively providing functional and logical partitioning for:

- Separating field power between input and output modules
- Separating field power to the analog and digital modules
- Grouping modules to perform a specific task or function

You can use multiple expansion power units with any of the communication adapters to assemble a full system. If you are using the PSSCDM12A adapter, you may use a PSSSE24A expansion power unit to add additional modules. For example, if you had a 36 module system with a PSSCDM12A adapter, you would have at least two or more PSSSE24A expansion power units to provide more bus power current for modules to the right of the supply.

- 1.3A of additional bus power
- Starts new voltage distribution
- Partitioning for E-Stop wiring

PSSSE24A Current Derating for Mounting

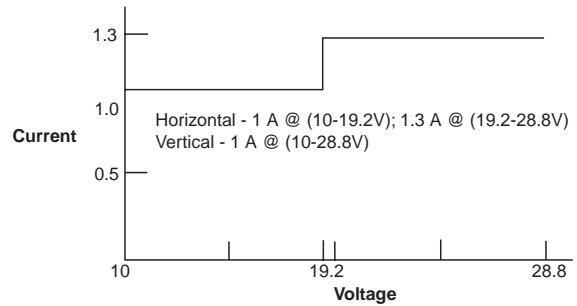

Power Distribution General Specifications

	PSSSE24A
Power Supply Requirements	Note: In order to comply with CE Low Voltage Directives (LVD), you must use a Safety Extra Low Voltage (SELV) or a Protected Extra Low Voltage (PELV) power supply to power this adapter
Field Side Power Requirements	24VDC (+20% = 28.8VDC max.) @ 400 mA
Inrush Current, Max.	6 A for 10 ms
Input Overvoltage Protection	Reverse polarity protected
Power Supply Interruption Protection	Output voltage will stay within specifications when input drops out for 10 ms at 10V with max. load
Power Supply Input Voltage, Nom.	24VDC
Operating Voltage Range	10...28.8VDC
Power Consumption, Max.	9.8 W @ 28.8VDC
Power Dissipation, Max.	3.0 W @ 28.8VDC
Thermal Dissipation, Max.	10.0 BTU/hr @ 28.8VDC
Isolation Voltage	1250V rms
Bus Power Supply Current, Max.	1.5 A
Field Power Supply Current, Max.	10 A

D
 Subbase & Manual
 Valves
 H Series
 Micro
 Moduteflex
 Series
 H Series
 ISO
 Fieldbus
 Systems
 DX ISOMAX
 Series
 Valvair II
 Series



For inventory, lead times, and kit lookup, visit www.pdnplu.com

Power Distribution Options for H Series ISO

H Series Fieldbus Communication and I/O Modules

An auxiliary 24VDC power supply from the communication module provides power to the backplane bus power and I/O module field power. You can connect up to 13 I/O modules with a maximum of 10 A field power, using the auxiliary power.

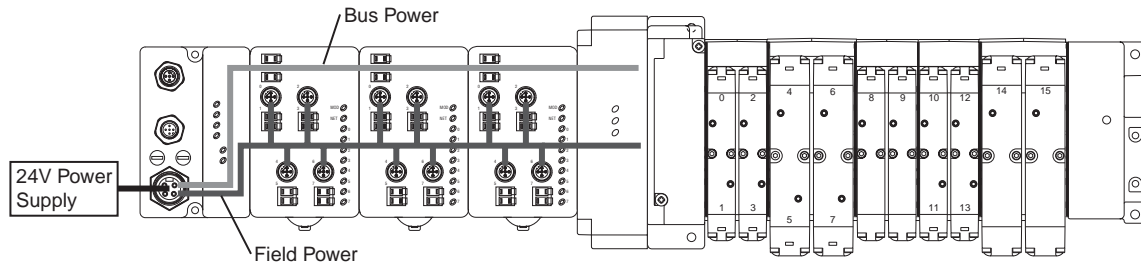

H Series Fieldbus System with 24VDC Expansion Power Unit (PSSSE24A)

The auxiliary power from the communication module supports up to 13 I/O modules with a maximum of 10 A field power. The 24VDC Power Extender Module (PSSSE24A) extends the backplane bus power and I/O Module field power to support up to 13 more I/O modules. Connect additional Power Extender Modules to expand the I/O assembly up to the maximum of 63 I/O modules. This secondary 24VDC connector on the PSSSE24A can be wired into an Emergency Stop circuit.

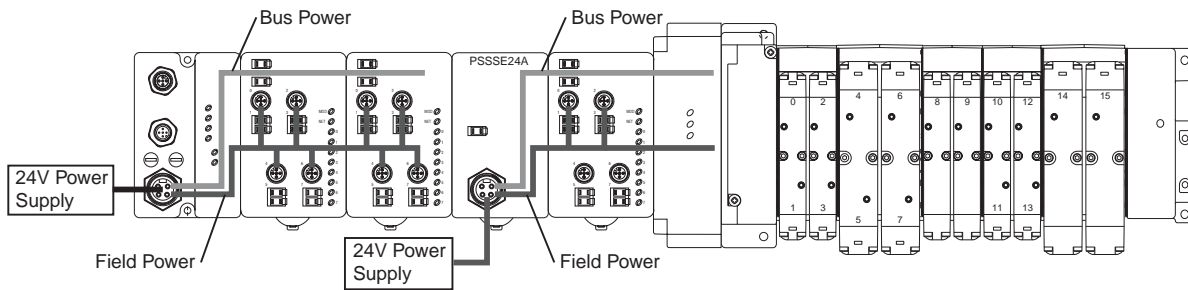

D

Subbase & Manual Valves

H Series Micro

Moduflex Series

H Series ISO

Fieldbus Systems

DX ISOMAX Series

Valvair II Series



For inventory, lead time, and kit lookup, visit www.pdnplu.com

Additional Power Distribution Options for H Series Micro

H Series Fieldbus Communication Module and Valve Driver Module with 24VDC Connector

The 24VDC power supply from the Communication Adaptor provides power to the backplane bus power and I/O module field power for up to 13 modules and an adapter with a maximum of 10 A Field Power. In this configuration, backplane bus power and I/O module field power are supplied to the input and output modules. The communication module only supplies backplane bus power to the Valve Driver Module, as the H Series Micro with 24VDC Connector separates the field power from the rest of the network. This secondary 24VDC Connector on the Valve Driver Module supplies Field Power to the valves, and can be wired into an Emergency Stop Circuit.

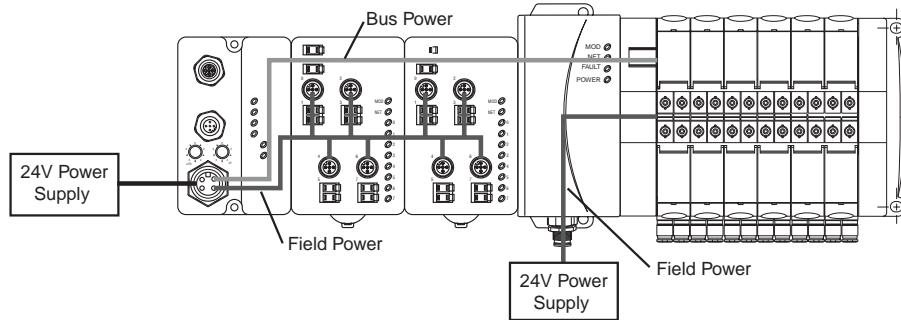

H Series Fieldbus Communication and I/O Modules

The 24VDC power supply from the communication module provides power to the backplane bus power and I/O module field power. You can connect up to 13 modules and an adapter with a maximum of 10 A field power, using this power source.

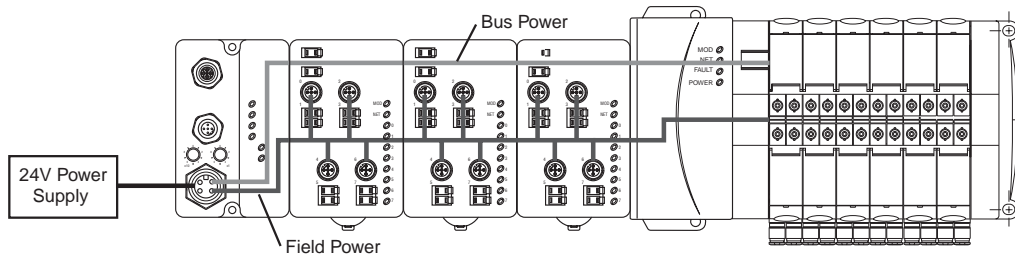

H Series Fieldbus Communication and I/O Modules

The 24VDC power supply from the communication module provides power to the backplane bus power and I/O module field power. You can connect up to 13 modules and an adapter with a maximum of 10 A field power, using this power source.

The 24VDC Power Extender Module (PSSSE24A) extends the backplane bus power and I/O module field power to support up to 13 more modules. Connect additional Power Extender Modules to expand the assembly up to the maximum of 63 I/O modules. The Valve Driver Module is the last module on the system, and will draw bus power and field power from the PSSSE24A to the left of it. This secondary 24VDC connector on the PSSSE24A can be wired into an Emergency Stop circuit.

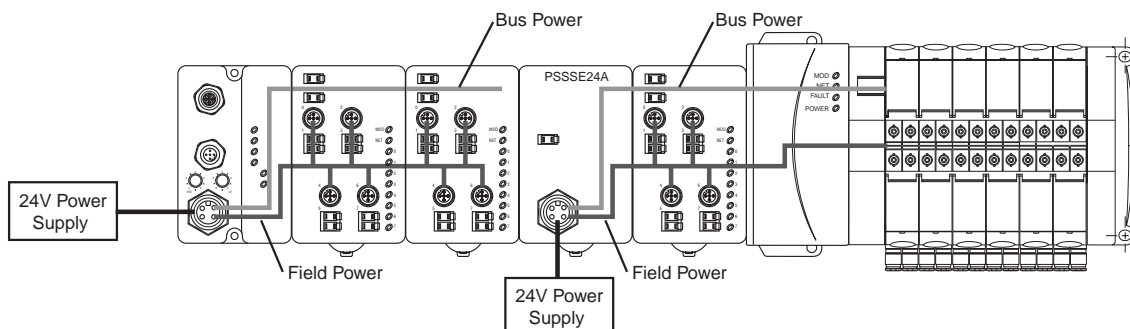

D	H Series Fieldbus Communication and I/O Modules
Subbase & Manual Valves	H Series Fieldbus Communication and I/O Modules
H Series Micro	H Series Fieldbus Communication and I/O Modules
Modulflex Series	H Series Fieldbus Communication and I/O Modules
H Series ISO	H Series Fieldbus Communication and I/O Modules
Fieldbus Systems	H Series Fieldbus Communication and I/O Modules
DX ISOMAX Series	H Series Fieldbus Communication and I/O Modules
Valvair II Series	H Series Fieldbus Communication and I/O Modules



For inventory, lead times, and kit lookup, visit www.pdnplu.com

D160

Parker Hannifin Corporation
 Pneumatic Division
 Richland, Michigan
www.parker.com/pneumatics

Power Distribution Options for H Series Micro (Continued)

H Series Fieldbus Communication Module with Bus Extension Connector and I/O Modules

The 24VDC power supply from the communication module provides power to the backplane bus power and I/O module field power. You can connect up to 13 modules and an adapter with a maximum of 10 A field power, using this power source. The H Series Micro with Bus Extension Connector carries backplane bus power and communication down to another H Series Fieldbus Assembly through the PSSVEXT1 cable. If additional H Series Fieldbus Input and Output Modules or H Series ISO valve manifold is used on this extension, a PSSSE24A Power Extender Module is required to provide Field Power. If the extension is attached directly to an H Series Micro Manifold, Field Power can be supplied directly by using the 24VDC Connector option.

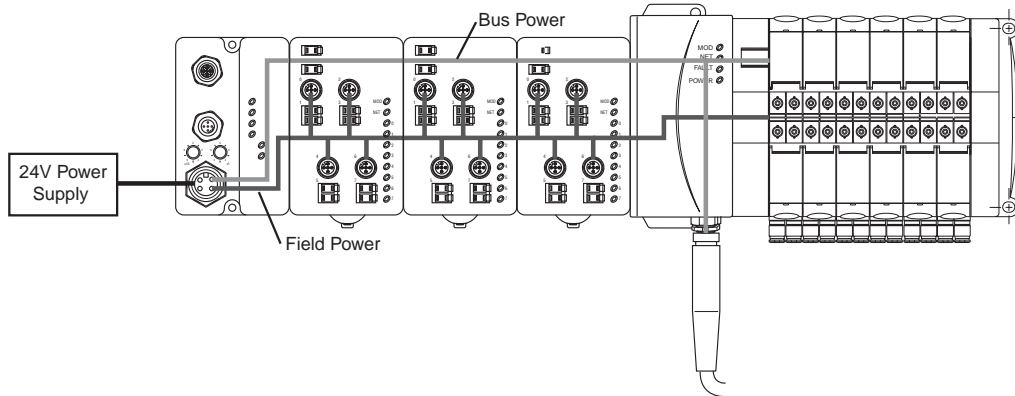

H Series Fieldbus Communication Module with 24VDC and Bus Extension Connectors and I/O Modules

The 24VDC power supply from the communication module provides power to the backplane bus power and I/O module field power. In this configuration, bus power and field power are supplied to the input and output modules. The communication module only supplies bus power to the Valve Driver Module, as the 24VDC Connector separates the Field Power from the rest of the network. This secondary 24VDC connector on the Valve Driver Module supplies field power to the valves, and can be wired into an Emergency Stop Circuit. The Bus Extension Connector carries bus power and communication down to another H Series Fieldbus Assembly through the PSSVEXT1 cable. If additional H Series Fieldbus input and output modules or H Series ISO valve manifold is used on this extension, a PSSSE24A Power Extender Module is required to provide field power. If the extension is attached directly to an H Series Micro Manifold with 24VDC Connector, field power can be supplied directly by using the 24VDC Connector option.

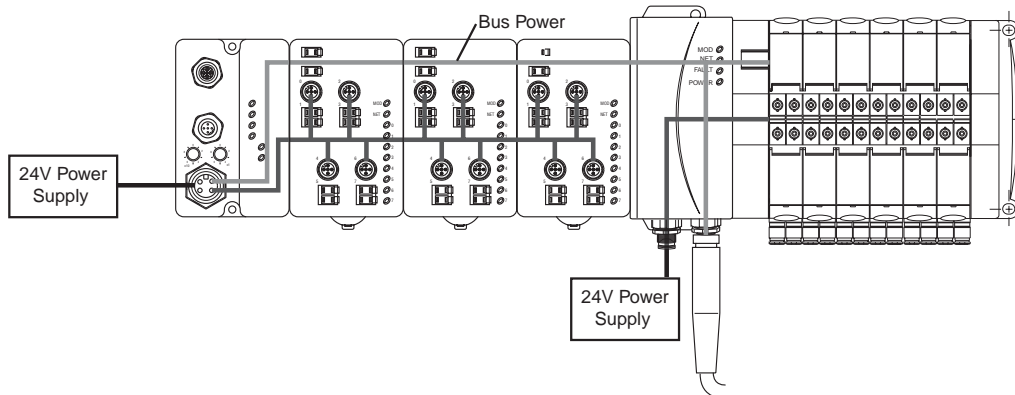

D

Subbase & Manual Valves

H Series Micro

Moduflex Series

H Series ISO

Fieldbus Systems

DX ISOMAX Series

Valvair II Series



For inventory, lead time, and kit lookup, visit www.pdnplu.com

Placing H Series Fieldbus Modules

Maximum Size Layout

Part number	Bus power supply	Maximum I/O modules with 24VDC backplane current at 75 mA each	Maximum I/O modules with expansion power supplies
PSSCDM12A on DeviceNet	1000	Up to 13	63
PSSCDM18PA on DeviceNet			
PSSCCNA on ControlNet			
PSSCENA on EtherNet/IP			
PSSCPBA on PROFIBUS			
PSSSE24A Expansion Power	Horizontal mounting: 1A @ 10...19.2V input; 1.3A @ 19.2...28.8V input Vertical mounting: 1A @ 10...28.8V input		

Power Supply Distance Rating

Modules are placed to the right of the power supply. Each H Series Fieldbus module can be placed in any of the slots to the right of the power supply until the usable backplane current of that supply has been exhausted. A Communication Module provides 1 A current to the PointBus. The Power Extend Module, PSSSE24A, provides up to 1.3 A and I/O modules require from 75 mA (typical for the digital and analog I/O modules) up to 90 mA or more.

Current Requirements

Part number	PointBus current requirements
PSSN8xxx	75 mA
PSSP8xxx	
PSST8xxx	
PSSN16xxx	90 mA
PSST16xxx	
PSSTR4MRA	75 mA
PSSNACM12A	
PSSTACM12A	
PSSNAVM12A	
PSSTAVM12A	
PSSV32A	
PSSVM32A	

D

Subbase & Manual Valves

H Series Micro

Modulflex Series

H Series ISO

Fieldbus Systems

DX ISOMAX Series

Valvair II Series



For inventory, lead times, and kit lookup, visit www.pdnplu.com

Related Documentation

Additional user documentation presents information according to the tasks you perform and the programming environment you use. Refer to the table below for information on H Series Fieldbus products.

H Series Fieldbus Related Publications*

	Part number	Description	Instruction sheet*
General Information	—	Industrial Automation Wiring and Grounding Guidelines	E115P
	—	Safety Guidelines for the Application, Installation and Maintenance of Solid State Control	E116P
Communication Interfaces	PSSCDM12A	H Series Fieldbus DeviceNet Adapter Module, Drop or Pass-through, with male and female M12 connectors	E101P, Installation Instructions PSS-UM001, User Manual
	PSSCDM18PA	H Series Fieldbus DeviceNet Adapter Module, Drop or Pass-through, with male and female M18 connectors	
	PSSCCNA	H Series Fieldbus Redundant ControlNet Adapter Module	E103P, Installation Instructions
	PSSCENA	H Series Fieldbus Ethernet/IP 10/100 Mbps Adapter Module	E104P, Installation Instructions
	PSSCPBA	H Series Fieldbus PROFIBUS Adapter Module	E102P, Installation Instructions
Valve Driver Module	PSSV32A, PSSVM32A	32 Point Valve Driver Module	E100P
DC I/O	PSSN16M12A	24VDC 16 Sink Input w/8 M12 connectors, 2 points per connector	
	PSSN8M8A	24VDC 8 Sink Input w/8 M8 connectors	
	PSSN8M12A	24VDC 8 Sink Input w/4 M12 connectors, 2 points per connector	E106P
	PSSN8M23A	24VDC 8 Sink Input w/1 M23 connector	
	PSSP8M12A	24VDC 8 Source Input w/4 M12 connectors, 2 points per connector	
	PSST16M23A	24VDC 16 Source Output w/1 M23	
	PSST16D25A	24VDC 16 Source Output w/1 25-Pin, D-Sub	
	PSST16M12A	24VDC 16 Source Output w/8 M12	E107P
	PSST8M8A	24VDC 8 Source Output w/1 M23	
	PSST8M12A	24VDC 8 Source Output w/4 M12	
Analog	PSSNACM12A	24VDC Analog Current Input w/ 2 M12 connectors	E110P
	PSSNAVM12A	24VDC 2 Analog Voltage Input w/ 2 M12 connectors	
	PSSTACM12A	24VDC Analog Current Output w/ 2 M12 connectors	E111P
	PSSTAVM12A	24VDC Analog Voltage Output w/ 2 M12 connectors	
Power Unit	PSSSE24A	24VDC Expansion Power Supply	E105P
Relay Output	PSSSTR4M12A	4 from A isolated (normally open) electromechanical relays	E109P

* Publications are electronic versions only. To make copies of these publications, go to: www.pdnplu.com

D

Subbase & Manual Valves

H Series Micro

Modulflex Series

H Series ISO

Fieldbus Systems

DX ISOMAX Series

Valvair II Series



For inventory, lead time, and kit lookup, visit www.pdnplu.com

Features

The Turck Fieldbus System

H Series Fieldbus has four major components:

- **Valve driver module** provide control for either 16 or 32 solenoids on a manifold
- **I/O modules** provide the field interface and system-interface circuitry
- **Communication modules** provide the network-interface circuitry
- **Power distribution module** provide 5 additional power inputs to the Turck system

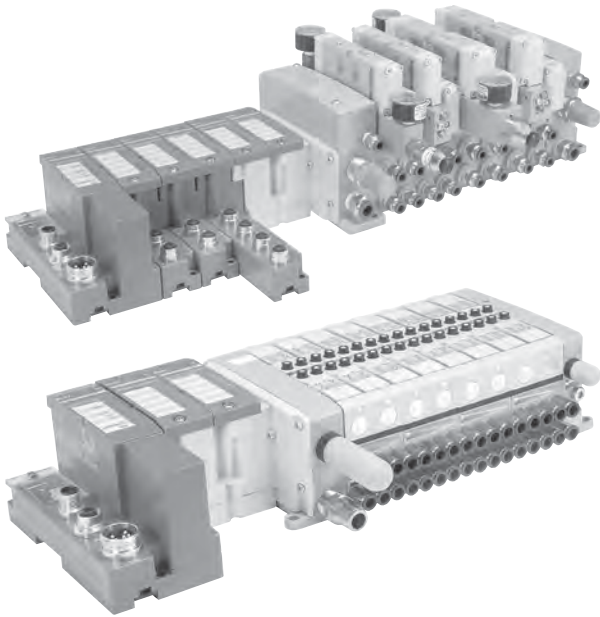

Subbase & Manifold Valve Products Turck Fieldbus System

Turck Features

- Highly modular design (4pt – 16pt modularity)
- Broad application coverage
- Channel-level diagnostics (LED and electronic)
- Channel-level alarm and annunciation (electronic)
- Channel-level open-wire detection with electronic feedback
- Channel-level short-circuit detection with electronic feedback
- Horizontal and vertical mounting without derating
- 5g vibration
- Electronic and mechanical keying
- Robust backplane design
- Quick-disconnects for I/O and network connectivity
- Built-in panel grounding
- Color-coded module labels
- UL, C-UL, and CE certifications (as marked)
- Highly reliable structural integrity
- Optical isolation between field and system circuits

D

Subbase & Manual
Valves

H Series
Micro

Modulflex
Series

H Series
ISO

Fieldbus
Systems

DX ISOMAX
Series

Valvair II
Series



For inventory, lead times, and kit lookup, visit www.pdnplu.com

D164

Parker Hannifin Corporation
Pneumatic Division
Richland, Michigan
www.parker.com/pneumatics

Turck Fieldbus System

- A complete fieldbus communication offering for all H Series ISO and H Series Micro valves.
- CSA, C-US and CE certifications (as marked).

I/O Configuration

- Centralized Turck Fieldbus system.
- Pneumatics and I/O are in close proximity with one another.
- M23, 12-Pin or 19-Pin output extension to an additional H Series valve island.
- I/O density per module = 4, 8 or 16.



Modbus/TCP™

CANopen

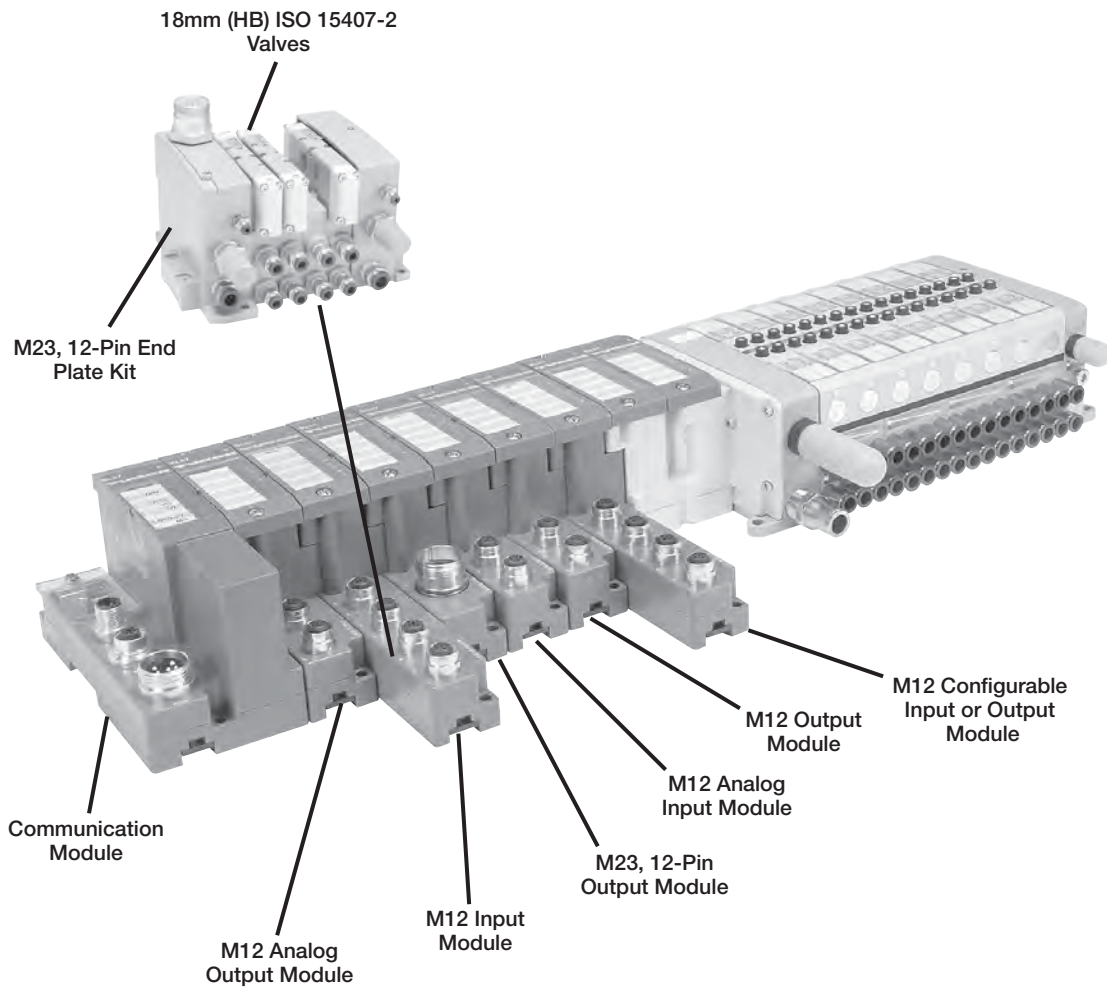

Configure / Program any module with RS232, or directly through Ethernet for any module with an Ethernet physical layer.



D

Subbase & Manual Valves

H Series Micro

Moduflex Series

H Series ISO

Fieldbus Systems

DX ISOMAX Series

Valvair II Series



For inventory, lead time, and kit lookup, visit www.pdnplu.com

D165

Parker Hannifin Corporation
 Pneumatic Division
 Richland, Michigan
www.parker.com/pneumatics

Turk Fieldbus System

- A complete fieldbus communication offering for all H Series ISO and H Series Micro valves.
- CSA, C-US and CE certifications (as marked).

I/O Configuration

- Complete control of all I/O and valves with stand alone control.
- Additional I/O and valves connected over DeviceNet with BL Remote Subnet.
- BL Remote connection to Moduflex and Turk fieldbus DeviceNet equipped communication modules.
- I/O density per module = 4, 8 or 16.

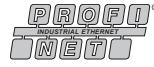

Modbus/TCP™

CANopen

D	Subbase & Manual Valves
	H Series Micro
Moduflex Series	H Series ISO
Fieldbus Systems	DX ISOMAX Series
Valvair II Series	

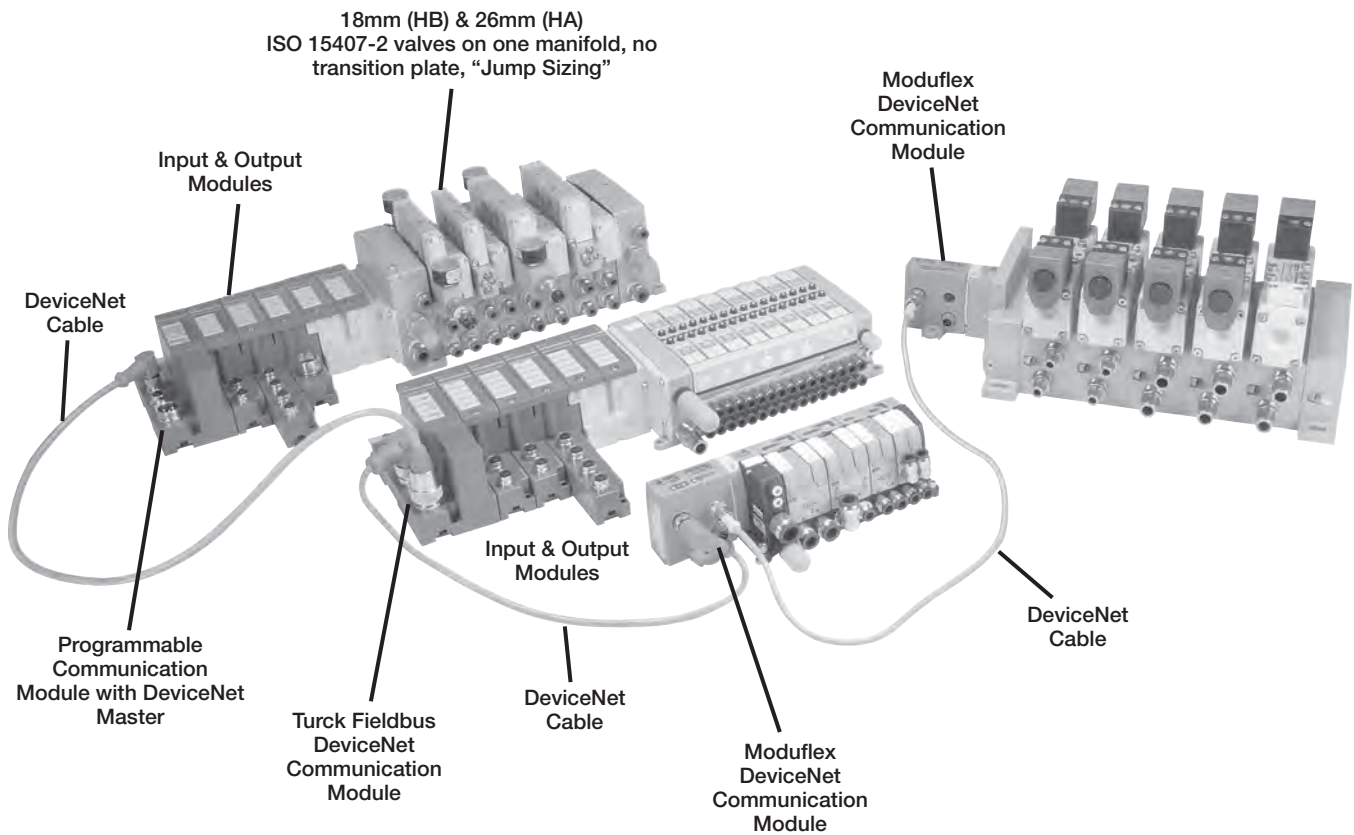

For inventory, lead times, and kit lookup, visit www.pdnplu.com

D166

Parker Hannifin Corporation
 Pneumatic Division
 Richland, Michigan
www.parker.com/pneumatics

Communications Module

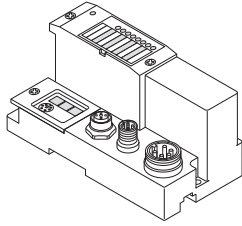

BL67 communication modules are the heart of a BL67 station. They are designed to connect the modular fieldbus nodes to the higher level fieldbus (PROFIBUS-DP, DeviceNet™, CANopen, Ethernet).

All BL67 electronic modules communicate over the internal module bus with the communication modules. The communication module structures the data and sends them clustered via fieldbus nodes to the higher control system.

This way all I/O modules can be configured independently of the fieldbus system.

Electronic Module

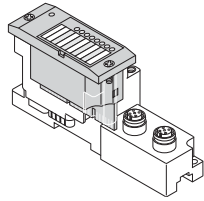

BL67 electronic modules are inserted into the passive base modules from above and then simply affixed with two screws. Maintenance is extremely simplified due to the separation of connection level and module electronics.

Moreover, flexibility is enhanced because the base modules provide different types of connectors. Voltage supply for the electronic modules is either provided via the communication modules or a Power Extender module. Power Extender modules can be used to create galvanically isolated potential groups.

Base Module

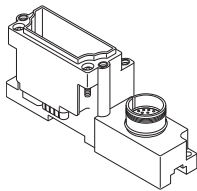

BL67 base modules are aligned one by one to the right of the communication module and are tightened each with two screws, either with the communication modules or with the previous module. A DIN rail is not required. This way a compact and stable unit is created which can be mounted directly on the machine.

The base modules serve for connection of the field devices and are available with different connection types (M8, M12, M23 and 7/8).

A BL67 system can be extended to a total length of 1 m, comprising of a communication module for PROFIBUS-DP, DeviceNet™/ CANopen or Ethernet and a maximum of 32 modules.

System supply: The power supply for the BL67 system is either derived separately for Profibus-DP and Ethernet communication modules or directly from the DeviceNet™ / CANopen cable for the DeviceNet™ / CANopen communication module.

Power Extender modules can be inserted anywhere in the BL67 station. They provide isolated field voltage for the I/O modules mounted to their right.

Thus Power Extender modules can also be used to create different potential groups.

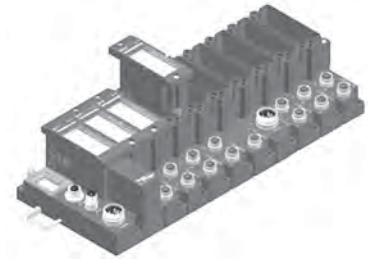

Maximum System Extension

Module type	PROFIBUS DP		DeviceNet		CANopen		ModbusTCP		EtherNet/IP		PROFIBUS NET		
	Number of chan.	Number of mod.	Number of chan.	Number of mod.	Number of chan.	Number of mod.	Number of chan.	Number of mod.	Number of chan.	Number of mod.	Number of chan.	Number of mod.	
Digital inputs	4 DI	128	32	128	32	128	32	128	32	128	32	128	32
	8 DI	256	32	256	32	256	32	256	32	256	32	256	32
Digital outputs	4 DO	128	32	128	32	128	32	128	32	128	32	128	32
	8 DO	256	32	256	32	256	32	256	32	256	32	256	32
	16 DO	512	32	512	32	512	32	512	32	512	32	512	32
Analog inputs	2AI	64	32	64	32	64	32	64	32	64	32	64	32
	4AI	112	28	124	31	124	31	128	32	128	32	128	32
	2 AI-PT	56	28	64	32	64	32	64	32	64	32	64	32
	2 AI-TC	64	32	64	32	64	32	64	32	64	32	64	32
Analog outputs	2 AO-I	38	19	64	32	64	32	64	32	64	32	64	32
	2 AO-V	38	19	50	25	50	25	50	25	50	25	50	25



For inventory, lead time, and kit lookup, visit www.pdnplu.com

BL67-GW-DN

DeviceNet Communication
 Module with Power over
 the Network

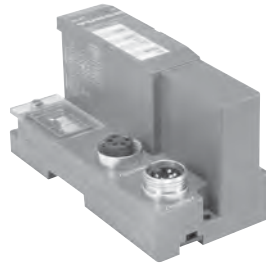

7/8 Mini bus in wiring,
 view into male connector

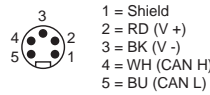

7/8 Mini bus out wiring,
 view into female connector

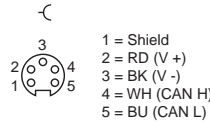

Turck Fieldbus System with up to 256 inputs, outputs, and 32 solenoids per H Series Micro or H Series ISO manifold. Digital inputs / outputs, analog inputs / outputs, serial interface, and counter modules are available. DeviceNet communication speeds selectable between 120, 250, 500 kbps, and CANopen communication speeds are selectable between 10 kbps up to 1 Mbps. Addressing for either module can be selected via rotary switches or set through software.

With the Power over the Network feature, it is only necessary to connect one cable to the communication module. For networks requiring additional power, a Bus Power Tee can be installed to combine separate network and power feeds into the communication module. See the Cables and Cordsets section for additional information.

BL67-GW-CO

CANopen Communication
 Module



M12 A-code bus out Wiring,
 view into female connector

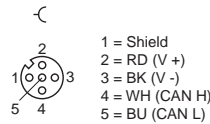

M12 A-code bus In Wiring,
 view into male connector

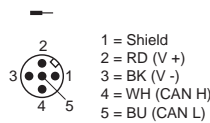

7/8 Mini Power in wiring,
 view into male connector

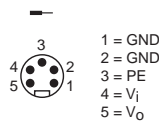

Turck Fieldbus System with up to 256 inputs, outputs, and 32 solenoids per H Series Micro or H Series ISO manifold. Digital inputs / outputs, analog inputs / outputs, serial interface, and counter modules are available. CANopen communication speeds are selectable between 10 kbps up to 1 Mbps, and addressing can be selected via rotary switches or set through software.

BL67-GW-DPV1

Profibus Communication
 Module

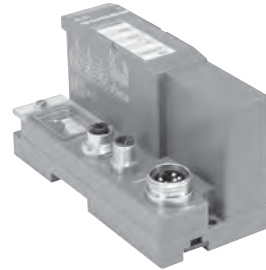

M12 B-code bus out Wiring,
 view into female connector

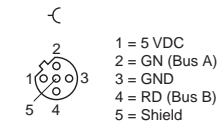

M12 B-code bus In Wiring,
 view into male connector

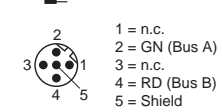

7/8 Mini Power in wiring,
 view into male connector

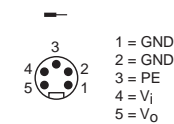

Turck Fieldbus System with up to 256 inputs, outputs, and 32 solenoids per H Series Micro or H Series ISO manifold. Digital inputs / outputs, analog inputs / outputs, serial interface, and counter modules are available. Profibus communication speeds are selectable between 9.6 kbps up to 12 Mbps, and addressing can be selected via rotary switches or set through software.

BL67-GW-EN

ModbusTCP, EtherNet / IP, and ProfiNet

BL67-GW-EN-PN

Profinet Communication Module

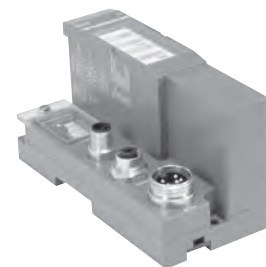

M12 D-code
 Ethernet in Wiring,
 view into female connector

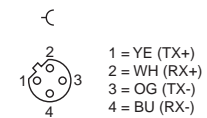

7/8 Mini Power in wiring,
 view into male connector

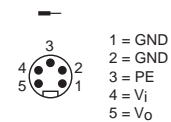

Turck Fieldbus System with up to 256 inputs, outputs, and 32 solenoids per H Series Micro or H Series ISO manifold. Digital inputs / outputs, analog inputs / outputs, serial interface, and counter modules are available. Communication speeds of 10/100 Mbps, and addressing can be selected via rotary switches, BOOTP, DHCP, or through software.

D	Subbase & Manual
	Valves
H Series	Micro
	Modulflex Series
H Series	ISO
	Fieldbus Systems
DXISOMAX Series	
	Valvair II Series



For inventory, lead times, and kit lookup, visit www.pdnplu.com

BL67-GW-EN-DN

Modbus / TCP Communication Module with DeviceNet Subnet

BL67-GW-EN-IP-DN

Ethernet / IP Communication Module with DeviceNet Subnet



DeviceNet OUT

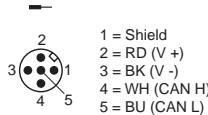

M12 D-code Ethernet in Wiring, view into female connector

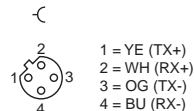

7/8 Mini Power in wiring, view into male connector

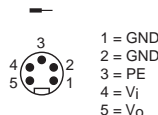

With BL Remote DeviceNet Subnet functionality, each communication module has its own DeviceNet master which provides a connection for 63 DeviceNet nodes with additional inputs, outputs, and solenoid control. BL Remote DeviceNet Subnet is independent of the main fieldbus network, and is not visible to the master PLC.

BL67-PG-EN-DN

Modbus / TCP Programmable Communication Module with DeviceNet Subnet

BL67-PG-EN-IP-DN

Ethernet / IP Programmable Communication Module with DeviceNet Subnet

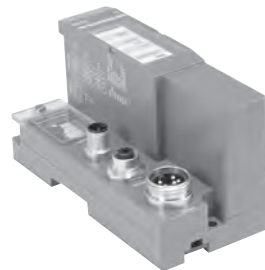

DeviceNet OUT

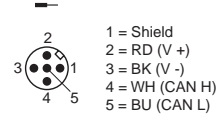

M12 D-code Ethernet in Wiring, view into female connector

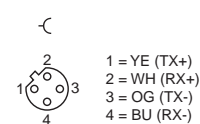

7/8 Mini Power in wiring, view into male connector

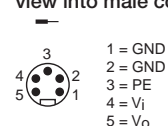

Communication modules are equipped with a built in standalone controller which is programmed according to IEC61131-3 with CoDeSys. Each module has 512KB Program memory with 32 bit RISC processor, and can run 1000 instructions in less than 1 ms. These fieldbus equipped modules are optimized to interface with PLC's with fieldbus capability or act as standalone controllers that need to interface with other fieldbus equipped devices.

With BL Remote DeviceNet Subnet functionality, each communication module has its own DeviceNet master which provides a connection for 63 DeviceNet nodes with additional inputs, outputs, and solenoid control. BL Remote DeviceNet Subnet is independent of the main fieldbus network, and is not visible to the master PLC.

BL67-PG-DP

Profibus Programmable Communication Module

BL67-PG-EN

Modbus / TCP Programmable Communication Module

BL67-PG-EN-IP

Ethernet / IP Programmable Communication Module



Profibus Wiring

M12 B-code bus out Wiring, view into female connector

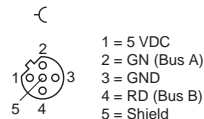

M12 B-code bus in Wiring, view into female connector

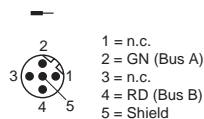

Ethernet Wiring

M12 D-code Ethernet in Wiring, view into female connector

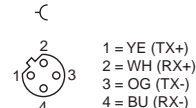

7/8 Mini Power in wiring, view into male connector Common to modules

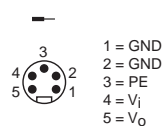

Communication modules are equipped with a built in standalone controller which is programmed according to IEC61131-3 with CoDeSys. Each module has 512KB Program memory with 32 bit RISC processor, and can run 1000 instructions in less than 1 ms. These fieldbus equipped modules are optimized to interface with PLC's with fieldbus capability or act as standalone controllers that need to interface with other fieldbus equipped devices.



For inventory, lead time, and kit lookup, visit www.pdnplu.com

D	Subbase & Manual Valves
	H Series Micro
D	Modulflex Series
	H Series ISO
D	Fieldbus Systems
	DX ISOMAX Series
D	Valvair II Series

D
 Subbase & Manual Valves
 H Series Micro
 Modulflex Series
 H Series ISO
 Fieldbus Systems
 DX ISOMAX Series
 Valvair II Series

Base Modules													
	BL67-B-4M8	BL67-B-8M8	BL67-B-1M12	BL67-B-1M12-8	BL67-B-2M12	BL67-B-2M12-P	BL67-B-4M12	BL67-B-4M12-P	BL67-B-1M23	BL67-B-1M23-19	BL67-B-1RSM	BL67-B-1RSM-4	BL67-1RSM-VO
Power Extender Modules													
BL67-PF-24VDC											✓	✓	✓
Digital Input Modules													
BL67-4DI-P	✓				✓	✓	✓		✓				
BL67-8DI-P		✓					✓	✓	✓				
BL67-4DI-PD	✓				✓	✓	✓		✓				
BL67-8DI-PD		✓					✓	✓	✓				
BL67-4DI-N	✓				✓	✓	✓		✓				
BL67-8DI-N		✓					✓	✓	✓				
Digital Output Modules													
BL67-4DO-0.5A-P	✓				✓	✓	✓		✓				
BL67-4DO-2A-P	✓				✓	✓	✓		✓				
BL67-8DO-0.5A-P		✓					✓	✓	✓				
BL67-16DO-0.1A-P										✓			
BL67-4DO-2A-N	✓				✓	✓	✓		✓				
BL67-8DO-0.5A-N		✓					✓	✓	✓				
Relay Output Modules													
BL67-8DO-R-NO								✓					
Digital Input / Output Modules													
BL67-4DI4DO-PD		✓					✓	✓	✓				
Configurable Digital Input / Output Modules													
BL67-8XSG-PD		✓					✓	✓	✓				
Analog Input Modules													
BL67-2AI-I					✓								
BL67-2AI-V					✓								
BL67-4AI-V/I							✓						
BL67-2AI-PT					✓								
BL67-2AI-TC					✓								
Analog Output Modules													
BL67-2AO-I					✓								
BL67-2AO-V					✓								
Technology Modules													
BL67-1RS232			✓	✓					✓				
BL67-1RS485/422			✓	✓					✓				
BL67-1SSI				✓					✓				
BL67-1CNT/ENC				✓					✓				
BL67-1CVI			✓										
BL Ident® RFID Modules													
BL67-2RFID-A					✓								
BL67-2RFID-S					✓								



For inventory, lead times, and kit lookup, visit www.pdnplu.com

D170

Parker Hannifin Corporation
 Pneumatic Division
 Richland, Michigan
www.parker.com/pneumatics

System Supply via the Module Bus

The number of BL67 modules that can be powered by the communication module, depends on the nominal current draw of all the modules in the system. The total bus power current consumption of the installed BL67 modules may not exceed 1.5 A. The total field power current for inputs may not exceed 4 A, and the total field power for outputs may not exceed 8 A for DeviceNet and CANopen with power over the network, or 10A for all other communication modules.

When using the software PACTware, the menu item <Station - Verify> will automatically generate an error message if the system supply via the module bus is not reliably ensured.

Nominal Current Consumption

The following table shows the nominal current consumption of the various BL67 modules:

Modules	Bus Power Current (mA)	Field Power for Inputs ¹⁾ (mA)	Field Power for Outputs (mA)
PROFIBUS-DP Communication Module	0		150
DeviceNet™ Communication Module	0		150
CANopen Communication Module	0		150
Ethernet Communication Module	0		150
Valve Driver with 16 Outputs	30		< 109 mA (Plus Load Current)
Valve Driver with 32 Outputs	60		< 218 mA (Plus Load Current)
BL67-PF-24VDC	30		9
BL67-4DI-P	30	< 49 mA	
BL67-4DI-N	30	< 10 mA	
BL67-4DI-PD	30	< 109 mA	
BL67-8DI-P	30	< 49 mA	
BL67-8DI-N	30	< 10 mA	
BL67-8-DI-PD	30	< 109 mA	
BL67-4DO-0.5A-P	30		< 109 mA (Plus Load Current)
BL67-4DO-2A-P	30		< 109 mA (Plus Load Current)
BL67-4DO-2A-N	30		< 109 mA (Plus Load Current)
BL67-8DO-0.5A-P	30		< 109 mA (Plus Load Current)
BL67-8DO-0.5A-N	30		< 109 mA (Plus Load Current)
BL67-16DO-0.1A-P	30		< 109 mA (Plus Load Current)
BL67-4DI4DO-PD	30		< 109 mA (Plus Load Current)
BL67-8XSG-PD	30		< 109 mA (Plus Load Current)
BL67-8DO-R-NO	30		< 109 mA (Plus Load Current)
BL67-2AI-V	35	< 22 mA	
BL67-2AI-I	35	< 22 mA	
BL67-4AI-I/V	35	< 22 mA	
BL67-2AI-TC	35	< 40 mA	
BL67-2AI-PT	45	< 58 mA	
BL67-2AO-I	40		< 62 mA
BL67-2AO-V	60		< 67 mA
BL67-1RS232	140	< 90 mA	
BL67-1RS485/422	60	< 42 mA	
BL67-1SSI	50	< 39 mA	
BL67-1CNT/ENC	30	< 109 mA	
BL67-1CVI	30	< 109 mA	





1) Is limited to 4 A by means of the integrated short-circuit protection.







For inventory, lead time, and kit lookup, visit www.pdnplu.com

Digital Input Modules

I/O modules	Voltage	Part number
 8 PNP input module	7 to 30 VDC	BL67-8DI-P
8 PNP input module, with diagnostics	7 to 30 VDC	BL67-8DI-PD
8 NPN input module	24 VDC	BL67-8DI-N





Base module	Part number
 8 x M8, 3 pole, female	BL67-B-8M8
 4 x M12, 5 pole, female, A-code	BL67-B-4M12
 4 x M12, 5 pole, female, A-code	BL67-B-4M12-P
 1 x M23, 12 pole, female	BL67-B-1M23

I/O modules	Voltage	Part number
4 PNP input module	7 to 30 VDC	BL67-4DI-P
4 PNP input module, with diagnostics	7 to 30 VDC	BL67-4DI-PD
4 NPN input module	24 VDC	BL67-4DI-N





Base module	Part number
 4 x M8, 3 pole, female	BL67-B-4M8
 2 x M12, 5 pole, female, A-code	BL67-B-2M12
 2 x M12, 5 pole, female, A-code	BL67-B-2M12-P
 4 x M12, 5 pole, female, A-code	BL67-B-4M12
 1 x M23, 12 pole, female	BL67-B-1M23

Digital Output Modules

I/O modules	Output current	Part number
 8 PNP output module	0.5 amps per channel	BL67-8DO-0.5A-P
8 NPN output module	0.5 amps per channel	BL67-8DO-0.5A-N

Base module	Part number
 8 x M8, 3 pole, female	BL67-B-8M8
 4 x M12, 5 pole, female, A-code	BL67-B-4M12
 4 x M12, 5 pole, female, A-code	BL67-B-4M12-P
 1 x M23, 12 pole, female	BL67-B-1M23

I/O modules	Output Current	Part number
4 PNP output module	0.5 amps per channel	BL67-4DO-0.5A-P
4 PNP output module	2 amps per channel	BL67-4DO-2A-P
4 PNP output module	4 amps per channel	BL67-4DO-4A-P
4 NPN output module	2 amps per channel	BL67-4DO-2A-N

Base module	Part number
 4 x M8, 3 pole, female	BL67-B-4M8
 2 x M12, 5 pole, female, A-code	BL67-B-2M12
 2 x M12, 5 pole, female, A-code	BL67-B-2M12-P
 4 x M12, 5 pole, female, A-code	BL67-B-4M12
 1 x M23, 12 pole, female	BL67-B-1M23

 Most popular.



For inventory, lead times, and kit lookup, visit www.pdnplu.com

D
 Subbase & Manual Valves
 H Series Micro
 Moduteflex Series
 H Series ISO
 Fieldbus Systems
 DX ISOMAX Series
 Valvair II Series

Digital Output Modules

I/O modules	Output current	Part number
16 PNP output module	0.14 amps per channel	BL67-16DO-0.1A-P

Base module	Part number
 1 x M23, 19 pole, female	BL67-B-1M23-19

Relay Output Modules

I/O modules	Output current	Part number
8 normally open relays	0.14 amps per channel	BL67-8DO-R-NO

Base module	Part number
 4 x M12, 5 pole, female, A-code	BL67-B-4M12-P

Analog Input Modules

I/O modules	Input type	Part number
4 configurable current or voltage analog input module	4 to 20 mA or 0 to 20 mA -10 to +10 VDC or 0 to +10 VDC	BL67-4AI-V/I

Base module	Part number
 4 x M12, 5 pole, female, A-code	BL67-B-4M12

I/O modules	Input type	Part number
2 Current analog input module	4 to 20 mA or 0 to 20 mA	BL67-2AI-I
2 Voltage analog input module	-10 to +10 VDC or 0 to +10 VDC	BL67-2AI-V
2 Temperature analog input module	PT100, PT200, PT500, PT1000, Ni100, Ni1000	BL67-2AI-PT
2 Temperature analog input module	Type B, E, J, K, N, R, S, T	BL67-2AI-TC

Base module	Part number
 2 x M12, 5 pole, female, A-code	BL67-B-2M12

 Most popular.

Combination Input / Output Modules

I/O modules	Input voltage & output current	Part number
4 PNP output 4 PNP input module, with diagnostics	7 to 30 VDC 0.5 Amps	BL67-4DI4DO-PD
8 PNP configurable input or output module, with diagnostics	7 to 30 VDC 0.5 Amps	BL67-8XSG-PD

Base module	Part number
 8 x M8, 3 pole, female	BL67-B-8M8

Base module	Part number
 4 x M12, 5 pole, female, A-code	BL67-B-4M12

Base module	Part number
 4 x M12, 5 pole, female, A-code	BL67-B-4M12P

Analog Output Modules

I/O modules	Input type	Part number
4 Voltage analog output module	-10 to +10 VDC or 0 to +10 VDC	BL67-4AO-V

Base module	Part number
 4 x M12, 5 pole, female, A-code	BL67-B-4M12

I/O modules	Input type	Part number
2 Current analog output module	4 to 20 mA or 0 to 20 mA	BL67-2AO-I
2 Voltage analog output module	-10 to +10 VDC or 0 to +10 VDC	BL67-2AO-V



Base module	Part number
 2 x M12, 5 pole, female, A-code	BL67-B-2M12



For inventory, lead time, and kit lookup, visit www.pdnplu.com

Combination Analog Input / Output Modules

I/O modules	Output current	Part number
4 configurable input and 4 configurable output current or voltage analog module	4 to 20 mA or 0 to 20 mA -10 to +10 VDC or 0 to +10 VDC	BL67-4AI4AO-V/I

Base module	Part number
 8 x M8, 3 pole, female	BL67-B-8M8
 4 x M12, 5 pole, female, A-code	BL67-B-4M12

CANopen Subnet Module

Extender module	Capacity	Part number
1 CANopen connection	64 bits of inputs or outputs	BL67-1CVI

Base module	Part number
 1 x M12, 5 pole, female, A-code	BL67-B-1M12



IO-Link Module

Extender module	Part number
4 Master Channels	BL67-4IOL

Base module	Part number
 4 x M12, 5 pole, female, A-code	BL67-B-4M12

Power Extender Module

Extender module	Current capacity	Part number
24 VDC field power module	10 amps input	BL67-PF-24VDC

Base module	Part number
 5 Pole mini connector to supply bus power and field power	BL67-B-1RSM
 5 Pole mini connector to field power only	BL67-B-1RSM-VO
 4 Pole mini connector to supply bus power and field power	BL67-B-1RSM-4



 Most popular.

I/O modules	Output current	Part number
2 configurable input and 2 configurable output current or voltage analog module	4 to 20 mA or 0 to 20 mA -10 to +10 VDC or 0 to +10 VDC	BL67-2AI2AO-V/I

Base module	Part number
 8 x M8, 3 pole, female	BL67-B-8M8



Serial Interface Module

Extender module	Capacity	Part number
1 RS232 serial interface	300 to 115200 bps	BL67-1RS232
1 RS485 or 422 serial interface	300 to 115200 bps	BL67-1RS485/422

Base module	Part number
 1 x M12, 5 pole, female, A-code	BL67-B-1M12
 1 x M12, 8 pole, female, A-code	BL67-B-1M12-8
 1 x M23, 12 pole, female	BL67-B-1M23

SSI and Counting Modules

Extender module	Capacity	Part number
1 SSI sensor interface	65 kbps up to 1 Mbps	BL67-1SSI
1 counter interface	Up to 250 kHz	BL67-1CNT/ENC

Base module	Part number
 1 x M12, 8 pole, female, A-code	BL67-B-1M12-8
 1 x M23, 12 pole, female	BL67-B-1M23

D

Subbase & Manual
Valves

H Series
Micro

Modulflex
Series

H Series
ISO

Fieldbus
Systems

DX ISOMAX
Series

Valvair II
Series



For inventory, lead times, and kit lookup, visit www.pdnplu.com

Digital PNP Input Modules

DC Input Module	BL67-4DI-P	BL67-8DI-P	BL67-4DI-PD	BL67-8DI-PD
Number of inputs	4	8	4	8
Sensor requirement	PNP Sourcing		PNP Sourcing	
Voltage, on-state input, nom.	24 VDC		24 VDC	
Field power for inputs current consumption	49 mA		109 mA	
Bus power current consumption	30 mA		30 mA	
Low level signal voltage	<4.5 V		<4.5 V	
High level signal voltage	7...30V		7...30V	
Low level signal current	<1.5 mA		<1.5 mA	
High level signal current	2.1...3.7 mA		2.1...3.7 mA	
Type of diagnostics	Group Diagnostics		Channel Diagnostics	
Short circuit protection	Group Protection		Channel Protection	
Input delay	0.25 ms		0.25; 2.5 ms	

PNP (Sourcing)

PNP input modules provide sourcing capabilities. When the input field device is passing, current flows from the input device into the Turck input module.

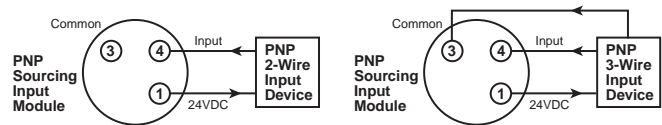

Digital NPN Input Modules

Digital DC Input Module	BL67-4DI-N	BL67-8DI-N
Number of inputs	4	8
Sensor requirement	NPN Sinking	NPN Sinking
Voltage, on-state input, nom.	24 VDC	24 VDC
Field power for inputs current consumption	10 mA	10 mA
Bus power current consumption	30 mA	30 mA
Low level signal voltage	>7 V	>7 V
High level signal voltage	<5 V	<5 V
Low level signal current	<2.5 mA	<1.2 mA
High level signal current	>3 mA	>1.5 mA
Type of diagnostics	Group Diagnostics	Group Diagnostics
Short circuit protection	Group Protection	Group Protection
Input delay	0.25 ms	0.25 ms

NPN (Sinking)

NPN input modules provide sinking capabilities. When the input field device is passing, current out of the Turck input module into the field input device.

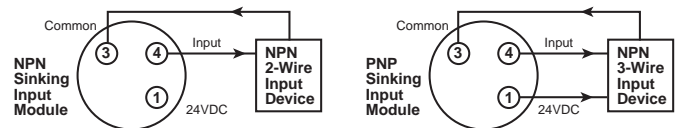

For inventory, lead time, and kit lookup, visit www.pdnplu.com

Digital PNP Output Modules

Digital DC Output Module	BL67-4DO-0.5A-P	BL67-8DO-0.5A-P	BL67-4DO-2A-P	BL67-16DO-0.1A-P
Number of outputs	4	8	4	16
Sensor requirement	PNP Sourcing	PNP Sourcing	PNP Sourcing	PNP Sourcing
Output voltage	24 VDC	24 VDC	24 VDC	24 VDC
Field power for outputs current consumption	109 mA (Plus load current)	109 mA (Plus load current)	109 mA (Plus load current)	109 mA (Plus load current)
Bus power current consumption	30 mA	30 mA	30 mA	30 mA
Output current per channel	0.5 A	0.5 A	2.0A	0.1 A
Output delay	3 ms	3 ms	3 ms	3 ms
Load type	Resistive, Inductive, Lamp Load	Resistive, Inductive, Lamp Load	Resistive, Inductive, Lamp Load	Resistive, Inductive
Load resistance, resistive	>48 Ohm	>48 Ohm	>12 Ohm	>250 Ohm
Load resistance, inductive	<1.2 H	<1.2 H	<1.2 H	<1.2 H
Lamp load	< 3W	< 3W	< 10W	< 10W
Switching frequency, resistive	<200 Hz	<200 Hz	<200 Hz	<200 Hz
Switching frequency, inductive	< 2 Hz	< 2 Hz	< 2 Hz	< 2 Hz
Switching frequency, lamp load	< 20 Hz	< 20 Hz	< 20 Hz	< 20 Hz
Short-circuit protection	Group Protection	Group Protection	Group Protection	Group Protection
Diagnostic bits	4	8	4	16

PNP (Sourcing)

PNP input modules provide sourcing capabilities. When the input field device is passing, current flows from the input device into the Turck input module.

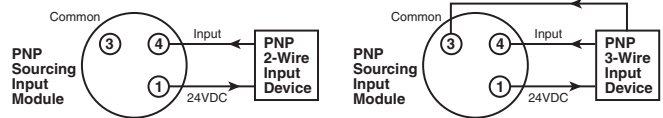

Digital NPN Output Modules

Digital DC Output Module	BL67-8DO-0.5A-N	BL67-4DO-2A-N
Number of outputs	8	4
Sensor requirement	NPN Sinking	NPN Sinking
Output voltage	24 VDC	24 VDC
Field power for outputs current consumption	109 mA (Plus load current)	109 mA (Plus load current)
Bus power current consumption	30 mA	30 mA
Output current per channel	0.5 A	2.0 A
Output delay	3 ms	3 ms
Load type	Resistive, Inductive, Lamp Load	Resistive, Inductive, Lamp Load
Load resistance, resistive	>48 Ohm	>48 Ohm
Load resistance, inductive	<1.2 H	<1.2 H
Lamp load	< 3W	< 3W
Switching frequency, resistive	<200 Hz	<200 Hz
Switching frequency, inductive	< 2 Hz	< 2 Hz
Switching frequency, lamp load	< 20 Hz	< 20 Hz
Short-circuit protection	Group Protection	Group Protection
Diagnostic bits	4	8

NPN (Sinking)

NPN input modules provide sinking capabilities. When the input field device is passing, current out of the Turck input module into the field input device.

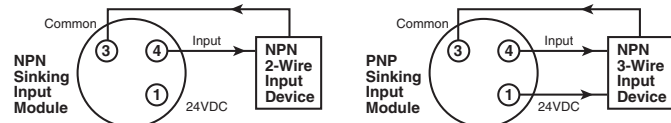

D
 Subbase & Manual Valves
 H Series Micro
 Modutefx Series
 H Series ISO
 Fieldbus Systems
 DX ISOMAX Series
 Valvair II Series



For inventory, lead times, and kit lookup, visit www.pdnplu.com

Relay Output Modules

Relay Output Module	BL67-8DO-R-NO
Number of outputs	8
Output type	Relay
Output voltage	24 VDC
Field power for outputs current consumption	109 mA (Plus load current)
Bus power current consumption	30 mA
Output current per channel	100 mA
Output delay	3 ms
Load type	Resistive, TTL logic
Switching resistor	<31 Ohm
Switching frequency, resistive	<200 Hz
Short-circuit protection	None

Combination Digital Modules

Combination Input and Output Modules	BL67-4DI4DO-PD	BL-67-8XSG-PD
Number of outputs	4	Configurable 0 to 8
Number of inputs	4	Configurable 0 to 8
Total channels	8	8
Sensor requirement	PNP Sourcing	PNP Sourcing
Voltage, on-state input, nom.	24 VDC	24 VDC
Output voltage	24 VDC	24 VDC
Field power for outputs current consumption	109 mA	109 mA
Bus power current consumption	30 mA	30 mA
Input low level signal voltage	<4.5 V	<4.5 V
Input high level signal voltage	7...30V	7...30V
Input low level signal current	<1.5 mA	<1.5 mA
Input high level signal current	2.1...3.7 mA	2.1...3.7 mA
Input delay	0.25; 2.5 ms	0.25; 2.5 ms
Output current per channel	0.5 A	0.5 A
Output delay	3 ms	3 ms
Load type	Resistive, Inductive, Lamp Load	Resistive, Inductive, Lamp Load
Load resistance, resistive	>48 Ohm	>48 Ohm
Load resistance, inductive	<1.2 H	<1.2 H
Lamp load	< 3W	< 3W
Switching frequency, resistive	<200 Hz	<200 Hz
Switching frequency, inductive	< 2 Hz	< 2 Hz
Switching frequency, lamp load	< 20 Hz	< 20 Hz
Short-circuit protection	Channel Protection	Channel Protection
Diagnostic bits	8	12

D

Subbase & Manual Valves

H Series Micro

Moduflex Series

H Series ISO

Fieldbus Systems

DX ISOMAX Series

Valvair II Series



For inventory, lead time, and kit lookup, visit www.pdnplu.com

D177

Parker Hannifin Corporation
 Pneumatic Division
 Richland, Michigan
www.parker.com/pneumatics

Analog Input Modules

Analog Input Module	BL67-2AI-I	BL67-2AI-V	BL67-4AI-V/I
Number of inputs	2	2	4
Nominal voltage	24 VDC	24 VDC	24 VDC
Field power for inputs current consumption	22 mA	22 mA	22 mA
Bus power current consumption	35 mA	35 mA	35 mA
Analog input type	0/4...20mA	-10/0...+10 VDC	0/4...20mA or -10/0...+10 VDC
Input resistance	<0.125 kOhm	<98.5 kOhm	<0.125 kOhm or <98.5 kOhm
Maximum limiting frequency	50 Hz		20 Hz
Fault limit @ 23 degree C	<0.2%		<0.3%
Repeatability	0.05%	0.05%	0.05%
Temperature coefficient (ppm/degree c of full scale)	<300	<150	<300
Resolution	16 Bit	16 Bit	16 Bit
Measuring principle	Sigma Delta	Sigma Delta	Sigma Delta
Measured value display	16 bit signed integer, 12 bit full range left justified	16 bit signed integer, 12 bit full range left justified	16 Bit signed integer, 12 bit full range left justified
Diagnostic bits	16		32

Temperature Inputs

Analog Input Module	BL67-2AI-PT	BL67-2AI-TC
Number of inputs	2	2
Nominal voltage	24 VDC	24 VDC
Field power for inputs current consumption	58 mA	40 mA
Bus power current consumption	45 mA	35 mA
Temperature input type	PT100, PT200, PT500, PT1000, Ni100, Ni1000	B, E, J, K, N, R, S, T
Voltage resolution	n/a	+/- 50mV; <2uV
Fault limit @ 23 degree C	<0.2%	<0.2%
Repeatability	0.05%	0.05%
Temperature coefficient (ppm/degree c of full scale)	<300	<300
Resolution	16 Bit	16 Bit
Measured value display	16 bit signed integer, 12 bit full range left justified	16 bit signed integer, 12 bit full range left justified
Diagnostic bits	16	16

D
Subbase & Manual Valves
H Series Micro
Modutrex Series
H Series ISO
Fieldbus Systems
DX ISOMAX Series
Valvair II Series



For inventory, lead times, and kit lookup, visit www.pdnplu.com

D178

Parker Hannifin Corporation
 Pneumatic Division
 Richland, Michigan
www.parker.com/pneumatics

Analog Input Modules

Analog Input Module	BL67-2AO-I	BL67-2AO-V
Number of inputs	2	2
Nominal voltage	24 VDC	24 VDC
Field power for outputs current consumption	62 mA	67 mA
Bus power current consumption	40 mA	60 mA
Analog output type	0/4...20mA	-10/0...+10 VDC
Output current per channel	n/a	250 mA
Load resistance, resistive	<0.45 kOhm	> 1kOhm
Load resistance, inductive	<1 mH	n/a
Load resistance, capacitive	n/a	> 1 uF
Transmission frequency	<200 Hz	<100 Hz
Fault limit @ 23 degree C	<0.2%	<0.2%
Repeatability	0.05%	0.05%
Temperature coefficient (ppm/degree c of full scale)	<150	<300
Resolution	16 bit	16 bit
Measured value display	16 bit signed integer, 12 bit full range left justified	16 bit signed integer, 12 bit full range left justified

Combination Analog Modules

Analog Combination Module	BL67-4AI4AO-V/I	BL67-2AI2AO-V/I
Number of analog inputs	4	2
Number of analog outputs	4	2
Nominal voltage	24 VDC	24 VDC
Field power for outputs current consumption	67 mA	67 mA
Bus power current consumption	60 mA	60 mA
Analog input type	0/4...20mA or -10/0...+10 VDC	0/4...20mA or -10/0...+10 VDC
Input resistance	0.065 or 225 kOhm	0.065 or 225 kOhm
Maximum limiting frequency	20 Hz	20 Hz
Fault limit @ 23 degree c	<0.3%	<0.3%
Repeatability	0.05%	0.05%
Temperature coefficient (ppm/degree c of full scale)	<300	<300
Resolution	16 bit	16 bit
Measuring principle	Sigma Delta	Sigma Delta
Measured value display	16 bit signed integer, 12 bit full range left justified	16 bit signed integer, 12 bit full range left justified
Analog output type	-10/0...+10 VDC	-10/0...+10 VDC
Output current per channel	250 mA	250 mA
Load resistance, resistive	>1 kOhm	>1 kOhm
Load resistance, capacitive	<1 uF	<1 uF
Transmission frequency	<100 Hz	<100 Hz
Fault limit @ 23 degree C	<0.3%	<0.3%
Repeatability	0.05%	0.05%
Temperature coefficient (ppm/degree c of full scale)	<300	<300
Resolution	16 bit	16 bit
Measured value display	16 bit signed integer, 12 bit full range left justified	16 bit signed integer, 12 bit full range left justified
Diagnostic bits	8	4

D

Subbase & Manual Valves

H Series Micro

Moduflex Series

H Series ISO

Fieldbus Systems

DX ISOMAX Series

Valvair II Series



For inventory, lead time, and kit lookup, visit www.pdnplu.com

D179

Parker Hannifin Corporation
 Pneumatic Division
 Richland, Michigan
www.parker.com/pneumatics

Power Extender Module

Power Extender Module	BL67-PF-24VDC
Nominal voltage	24 VDC
Field power for outputs current consumption	9 mA
Bus power current consumption	30 mA
Supply for field power for inputs current	4.0 A
Supply for field power for outputs current	10 A
Diagnostic bits	3

RS232 Interface

RS232 Interface	BL67-1RS232
Number of channels	1
Field power for inputs current consumption	90 mA
Bus power current consumption	140 mA
Transmission level active (u rs1)	-15 to -3 VDC
Transmission level inactive (urso)	3 to 15 VDC
Common-mode range (ugl)	-7 to 12 VDC
Transmission signals	RxD, TxD, RTS, CTS
Data buffer received	128 Byte
Send data buffer	64 Byte
Connection type	Full Duplex
Transmission rate	300 to 115200 bps
Parameter	Transmission Rate, Diagnostics, Data Bits, Stop Bits, XON - Character, XOFF - Character, Parity, Flow Control
Cable length	15 m
Diagnostic bits	8

RS485 / 422 Interface

RS485/422 Interface	BL67-1RS485/422
Number of channels	1
Field power for inputs current consumption	42 mA
Bus power current consumption	60 mA
Transmission signals	RxD, TxD
Connection type	2 Wire Half Duplex or 4 Wire Full Duplex
Transmission rate	300 to 115200 bps
Parameter	RS485/422, Transmission Rate, Diagnostics, Data Bits, Stop Bits, XON - Character, XOFF - Character, Parity, Flow Control
Cable length	1000 m
Line impedence	120 Ohm
Bus termination	External
Diagnostic bits	8

D
 Subbase & Manual
 Valves
 H Series
 Micro
 Modutefx
 Series
 H Series
 ISO
 Fieldbus
 Systems
 DXISOMAX
 Series
 Valvair II
 Series



For inventory, lead times, and kit lookup, visit www.pdnplu.com

D180

Parker Hannifin Corporation
 Pneumatic Division
 Richland, Michigan
www.parker.com/pneumatics

SSI Sensor Interface

SSI Sensor Interface	BL67-1SSI
Number of channels	1
Field power for inputs current consumption	39 mA
Bus power current consumption	50 mA
Transmission signals	CL, D
Connection type	4 Wire Full Duplex (Clock Output/Signal Input)
Transmission rate	62.5 kbps up to 1 Mbps
Parameter	Transmission Rate, Diagnostics, Data Format (Binary / GRAY coded), Data Fram Bits (1-32), Number of Invalid Bits (LSB: 0-15, MSB 0-7)
Cable length	30 m
Diagnostic bits	8

Counting Module

Counting Module	BL67-1CNT/ENC
Number of channels	1
Field power for inputs current consumption	109 mA
Bus power current consumption	30 mA
Input type	PNP
Output type	PNP
Output current per channel	0.5 A
Output delay	2 ms
Load type	Resistive
Frequency measurement	Up to 250 kHz
Speed measurement	Factor Configurable
Period duration measurement	2 usec
Upper count limit	0x80000000 up to 0xFFFFFFFF
Lower count limit	0x80000000 up to 0xFFFFFFFF
Short circuit protection	Channel Protection

CANopen Expansion Module

CANopen Expansion Module	BL67-1CVI
Number of channels	1
Field power for inputs current consumption	109 mA
Bus power current consumption	30 mA
Transmission signals	CAN High, CAN Low
Connection type	CANopen
Transmission speed	10 kbps up to 1 Mbps
Parameter	Transmission Rate, Diagnostics, Bus Termination, Range of I/O Data
Bus termination	Internal
Diagnostic bits	48
Max number of CANopen nodes	8
Max processing data per module	8 Byte
Max data per node	4 Byte



For inventory, lead time, and kit lookup, visit www.pdnplu.com

D181

Parker Hannifin Corporation
 Pneumatic Division
 Richland, Michigan
www.parker.com/pneumatics

D

Subbase & Manual Valves

H Series Micro

Moduflex Series

H Series ISO

Fieldbus Systems

DX ISOMAX Series

Valvair II Series

Power Distribution Options for Turck Fieldbus

Turck Communication and I/O Modules - DeviceNet and CANopen, Power over Network

The 24VDC power supply pins from the DeviceNet or CANopen network connection on the communication module provides a single power circuit. This circuit provides 1.5 A bus power, 4 A field power for inputs and 8A field power for outputs.

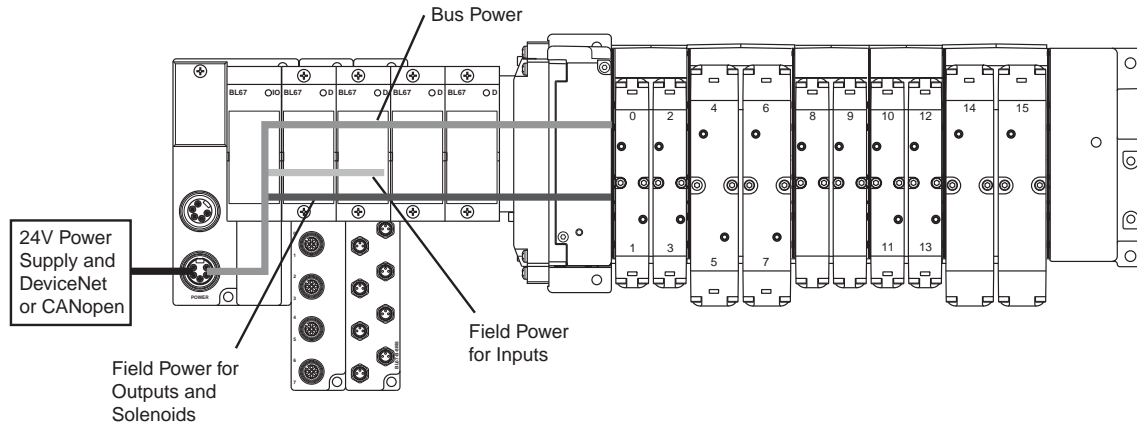

Turck Communication and I/O Modules - Ethernet/IP, Modbus/TCP, Profinet, Profibus, and CANopen

An auxiliary 24VDC power supply from the communication module provides power across two separate circuits. The first circuit provides 1.5 A bus power and 4 A field power for inputs. The second circuit provides 10A field power for outputs which can be wired to an e-stop circuit to kill all outputs.

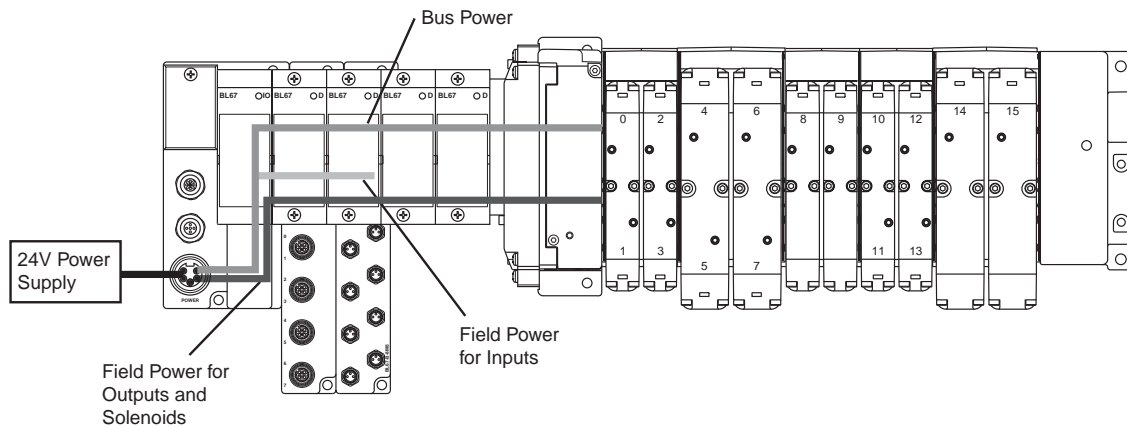

D	Subbase & Manual
Valves	H Series Micro
Series	Modulflex Series
H Series	ISO
Fieldbus Systems	DX ISOMAX Series
Valvair II Series	



For inventory, lead times, and kit lookup, visit www.pdnplu.com

Power Distribution Options for Turck Fieldbus (continued)

24VDC Power Extender Module (BL67-PF-24VDC) with Base Module BL67-B-1RSM

This configuration creates an auxiliary 24VDC power supply and provides power across two separate circuits, regardless of the communication module used. The first circuit provides 4 A field power for inputs. The second circuit provides 10A field power for outputs which can be wired to an e-stop circuit to kill all outputs and solenoids to the right of the module. The 1.5 A bus power is uninterrupted, and is still supplied from the communication module.

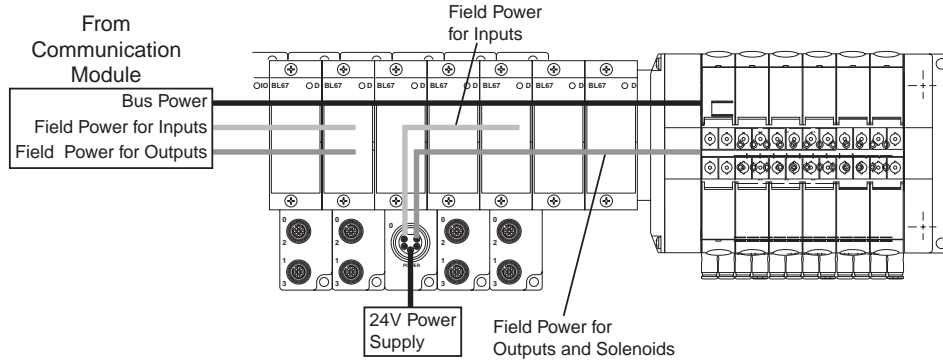

24VDC Power Extender Module (BL67-PF-24VDC) with Base Module BL67-B-1RSM-4

This configuration creates an auxiliary 24VDC power supply and provides power across one circuit, regardless of the communication module used. This circuit provides 4 A field power for inputs and 10A field power for outputs. The 1.5 A bus power is uninterrupted, and is still supplied from the communication module.

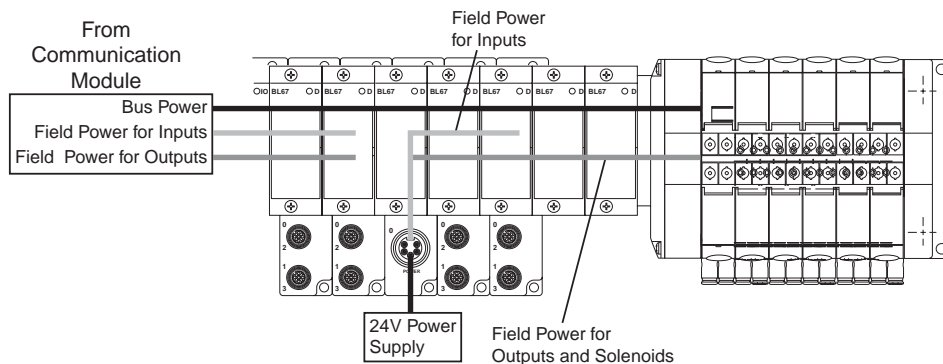

24VDC Power Extender Module (BL67-PF-24VDC) with Base Module BL67-B-1RSM-VO

This configuration creates an auxiliary 24VDC power supply and provides power across one circuit, regardless of the communication module used. This circuit provides 10A field power for outputs which can be wired to an e-stop circuit to kill all outputs and solenoids to the right of the module. The 1.5 A bus power and 4 A field power for inputs are uninterrupted, and are still supplied from the communication module.

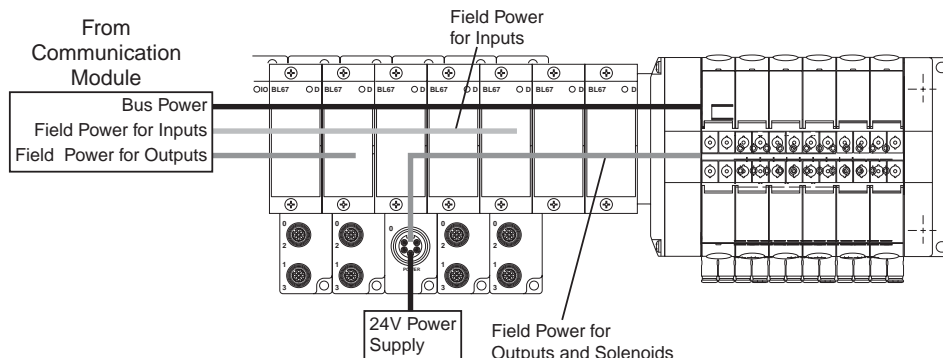

For inventory, lead time, and kit lookup, visit www.pdnplu.com

D183

Parker Hannifin Corporation
 Pneumatic Division
 Richland, Michigan
www.parker.com/pneumatics

D

Subbase & Manual Valves

H Series Micro

Moduflex Series

H Series ISO

Fieldbus Systems

DX ISOMAX Series

Valvair II Series

7/8" Mini Power Cables

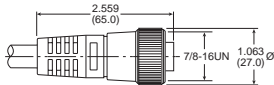
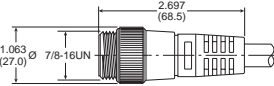
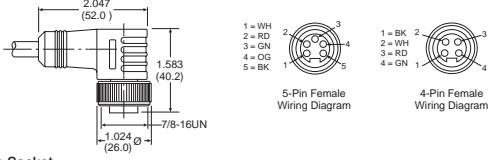
	Description	Part number
 RKM Female Socket	4-pin female to flying lead cable, 5 meters, TPE	RKM 46-5M/S1587
	5-pin female to flying lead cable, 5 meters, TPE	RKM 56-5M/S1587
 RSM Male Pins	4-pin male to female cable, TPE	RSM RKM 46-x/S1587
	5-pin male to female cable, TPE	RSM RKM 56-x/S1587
 WKM Female Socket	4-pin right angle female to flying lead cable, 5 meters, TPE	WKM 46-5M/S1587
	5-pin right angle female to flying lead cable, TPE	WKM 56-5M/S1587
	Where x = 2, 4, 5, 6, 8, 10 meter standard lengths	

Power Tee

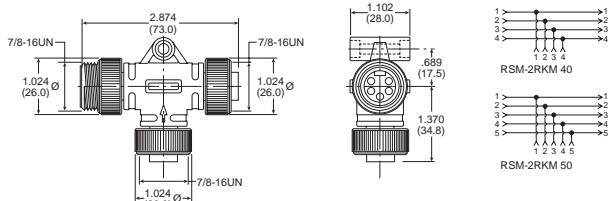
	Description	Part number
	4-pin Male to 2 female sockets	RSM-2RKM 40
	5-pin Male to 2 female sockets	RSM-2RKM 50

M12 A-code Cables

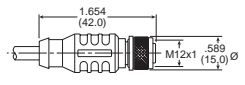
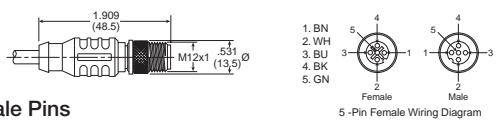
	Description	Part number
 RKC Female Sockets	4-pin female to flying lead cable, PVC	RKC 4.4T-1
	4-pin male to flying lead cable, PVC	RSC 4.4T-*
 RSC Male Pins	4-pin male to female cable, PVC	RKC 4.4T-*/-RSC 4.4T
	5-pin female to flying lead cable, TPE	RKC 4.5T-*/S1587
	5-pin male to flying lead cable, TPE	RSC 4.5T-4/S1587
	5-pin male to female cable, TPE	RKC 4.5T-*/-RSC 4.5T/S1587
	Where * = 1, 2, 3, 4 meter standard lengths	

M8 Cables

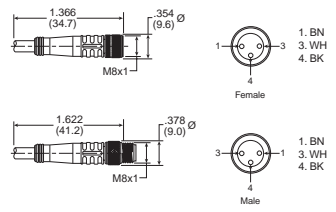
	Description	Part number
	3-pin female to flying lead cable, PUR	PKG 3M-4/S90
	3-pin male to flying lead cable, PUR	PSG 3M-*/S90
	3-pin male to female cable, PUR	PKG 3M-*/-PSG 3M/S90
	Where * = 1, 2, 3, 4 meter standard lengths	

 Most popular.

D
 Subbase & Manual Valves
 H Series Micro
 Moduteflex Series
 H Series ISO
 Fieldbus Systems
 DX ISOMAX Series
 Valvair II Series



For inventory, lead times, and kit lookup, visit www.pdnplu.com

D184

Parker Hannifin Corporation
 Pneumatic Division
 Richland, Michigan
www.parker.com/pneumatics

M23 Cables

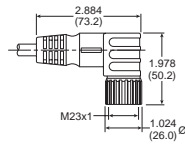
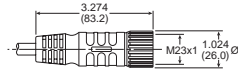

Description	Part number
12-pin, double ended female thread with male pins and female socket, PUR. Pinout optimized for H Series Fieldbus.	CSCM CKCM 12-11-x/S90
19-pin, double ended female thread with male pins and female socket, PUR. Pinout optimized for H Series Fieldbus.	CSM CKM 19-19-x/S90
19-pin, 90° double ended female thread with male pins and female socket, PUR. Pinout optimized for turck fieldbus.	CSWM CKWM 19-19-x/CS12852

Where x = 1, 2, 3, 4 meter standard lengths

Profibus Cables

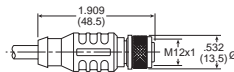
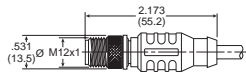

Description	Part number
M12 Male to M12 Female, PUR	RSSW RКСW 455-xM

Where x = 2, 4, 5, 6, 8, 10 meter standard lengths

RSSW Side, Male Pins

RКСW Side, Female Sockets

Profibus Terminating Resistor

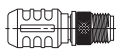

Male Pins

Description	Part number
M12 male pin terminating resistor	P8BPA00MB

Ethernet Cables

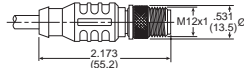
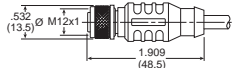

RKSD Side, Female Sockets

RSSD Side, Male Pins

Description	Part number
M12 female to M12 male, PUR	RSSD RKSD 443-xM
RJ45 to M12 male, PUR	RSSD RJ45S 443-2M

Where x = 2, 5, 10, 15, 20, 30 meter standard lengths

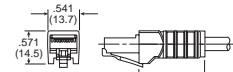

RJ45S Side

25-pin, D-Sub Cable (Female)

Description	Length	Part number
25-pin, D-sub cable, IP20	3 meters	P8LMH25M3A
25-pin, D-sub cable, IP20	9 meters	SCD259D
25-pin, D-sub cable, IP65	3 meters	SCD253W
25-pin, D-sub cable, IP65	9 meters	SCD259WE

Most popular.



For inventory, lead time, and kit lookup, visit www.pdnplu.com

DeviceNet and CANopen Cables

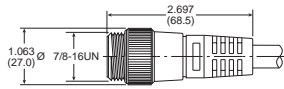

RSM Side, 7/8 Mini with Male Pins

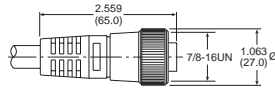

RKM Side, 7/8 Mini with Male Pins

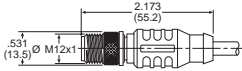

RSC Side, Male Pins

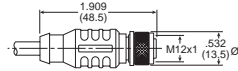

RKC Side, Female Sockets

Description	Part number
7/8" mini male to 7/8" mini female, PUR	RSM RKM 5711-xM
7/8" mini male to M12 female, PUR	RSM RKC 5711-xM
M12 male to M12 female, PUR	RSC RKC 5711-xM
M12 male to 7/8" mini female, PUR	RSC RKM 5711-xM

Where x = 2, 4, 5, 6, 8, 10 meter standard lengths

Bus Power Tee

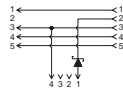
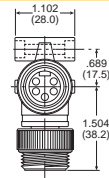
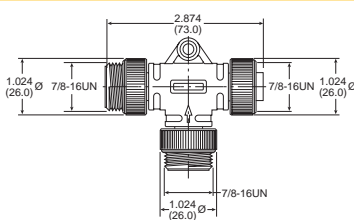

Description	Part number
Bus power tee	RSM RKM 57 WSM 40 PST

For systems not equipped with Power over network, combines separate network and power feeds into the communication module. Includes reverse current protection

DeviceNet and CANopen Terminating Resistor

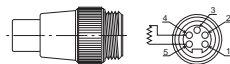

RSM 57-TR2

Male Pins

Description	Part number
7/8" Mini Male Pin Terminating Resistor	RSM 57-TR2
M12 Male Pin Terminating Resistor	P8BPA00MA

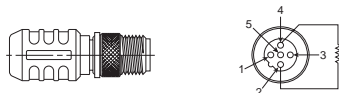

P8BPA00MB

Male Pins

Most popular.



For inventory, lead times, and kit lookup, visit www.pdnplu.com

D
 Subbase & Manual Valves
 H Series Micro
 Modutefx Series
 H Series ISO
 Fieldbus Systems
 DX ISOMAX Series
 Valvair II Series

19-Pin Round Brad Harrison

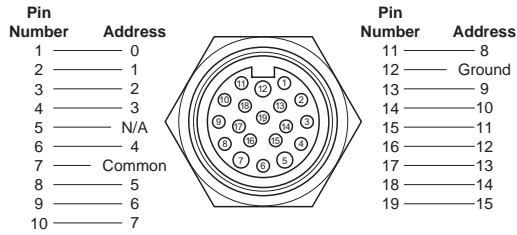

Face View - Male 19-Pin Connector

19-Pin Round Cable Specifications

Common Pin "7" is rated for 8 amps. Cable common wire must be greater than total amperage of solenoids on Add-A-Fold assembly.

Example: 8 station manifold, 16 solenoids,
 120VAC - 16 x .039 amps = .63 total amp rating.

NEMA 4 rated with properly assembled NEMA 4 rated cable.

25-Pin, D-Sub Connector (Male)

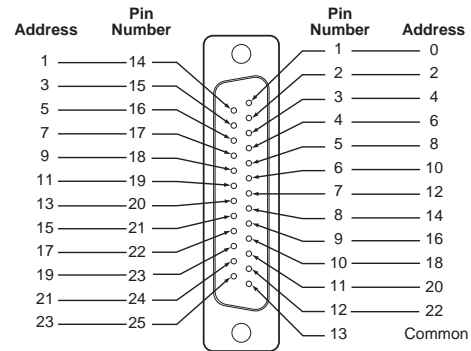

View into End Plate Connector - Male D-Sub, 25-Pin

M23, 12-Pin Round Connector (Male)

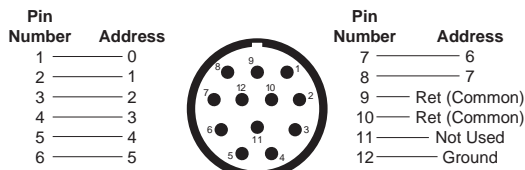

Face View - Male 12-Pin Connector

M23, 19-Pin Round Connector (Male)

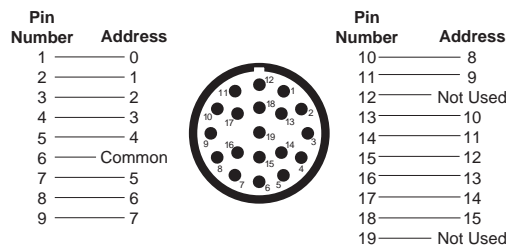

View into End Plate Connector - Male M23, 19-Pin

25-Pin, D-Sub Cable (Female)

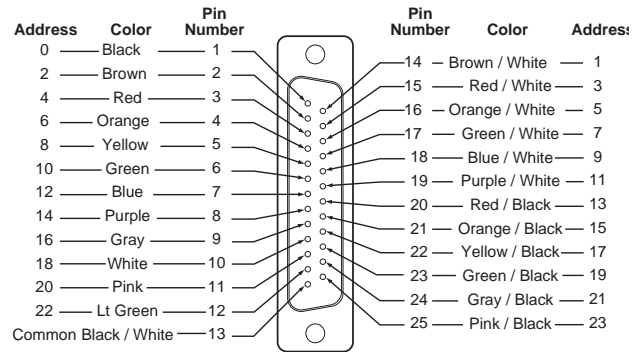

 Most popular.



For inventory, lead time, and kit lookup, visit www.pdnplu.com

		Modulflex					H Series Fieldbus				Turck Fieldbus					
		AS-i	CANopen	DeviceNet	Interbus	Profibus	ControlNet	DeviceNet	EtherNet	Profibus	CANopen	DeviceNet	Ethernet/IP	Modbus/TCP	Profibus	Profinet
Rockwell Automation	PLC-5™			X								X				
	SLC 500™			X								X	X			
	1756 Logix™			X								X	X			
	1769-L32C, -35CR			X			X	X	X			X	X			
	1769 CompactLogix™			X			X	X	X			X	X			
	SoftLogix5800™			X			X	X	X			X	X			
	FlexLogix™			X			X	X	X			X	X			
	1789 ControlLogix™			X			X	X	X			X	X			
Siemens	SIMATIC S7-200	X				X				X					X	
	SIMATIC S7-300	X				X				X					X	
	SIMATIC S7-400					X				X					X	X
	SIMATIC S7-1200					X				X					X	X
Omron	SYSMAC One			X								X				
	SYSMAC CJ1			X								X				
	SYSMAC CJ2			X								X				
	SYSMAC CP1			X								X				
	SYSMAC CS1			X								X				
	SYSMAC CQM1H			X								X				
	SYSMAC Alpha			X								X				
	SYSMAC CVM1/CV			X								X				
	SYSMAC CPM			X								X				
Schneider	Modicon Premium		X		X	X				X	X		X	X	X	
	Quantum	X			X							X	X			
	M340™	X	X							X		X	X			
	Momentum™											X	X			
Automation Direct	Productivity 3000			X								X				
	DirectLogic 05			X								X				
	DirectLogic 06			X								X				
	DirectLogic 105			X								X				
	DirectLogic 205			X								X	X	X		
	DirectLogic 305			X								X	X	X		
	DirectLogic 405			X								X	X	X		

Note: Confirm manufacturers specifications to ensure product compatibility.

D
Subbase & Manual Valves
H Series Micro
Modulflex Series
H Series ISO
Fieldbus Systems
DX ISOMAX Series
Valvair II Series



For inventory, lead times, and kit lookup, visit www.pdnplu.com

D188

Parker Hannifin Corporation
 Pneumatic Division
 Richland, Michigan
www.parker.com/pneumatics

Basic Systems

- Up to 24 solenoids per manifold
- Discretely wired solenoids - Optimized for PLCs with onboard Inputs and Outputs
- 25-Pin D-Sub, 19-Pin Brad Harrison or M23, or 12-Pin M23 connectors available.

Centralized Application

Valves Inside Control Cabinet

- Valves located near machine control
- Applications with caustic wash down, hazardous areas, or extreme temperatures

Advantages

- Highest degree of environmental protection
- One location for all control devices
- Small size requires minimal cabinet space
- Eliminates junction boxes required for valves
- Eliminates conduit runs for valves

Decentralized Application

Valves Outside Control Cabinet

- Valves located near application - Ready for machine mounting
- IP65 rating suitable for dusty and wet environments

Advantages

- Reduces control cabinet size
- Reduces tubing length and improves pneumatic response time
- Eliminates pneumatic bulk fittings on control cabinet

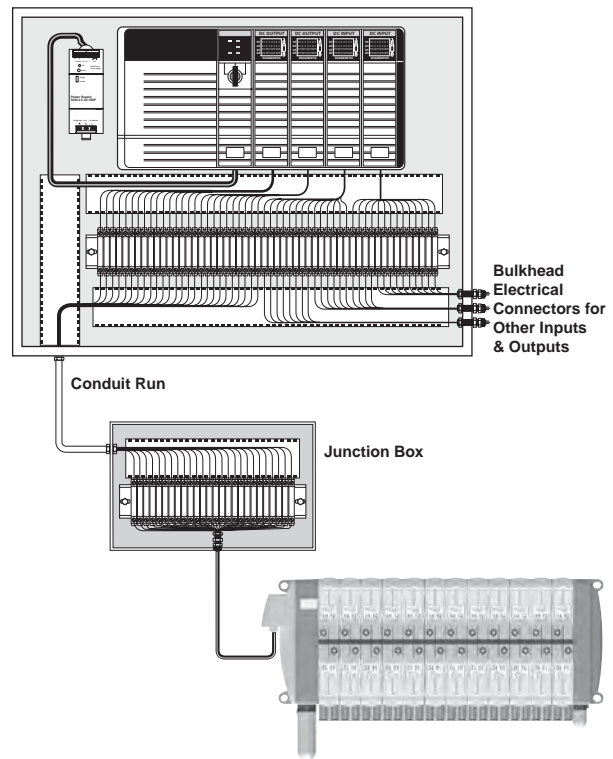
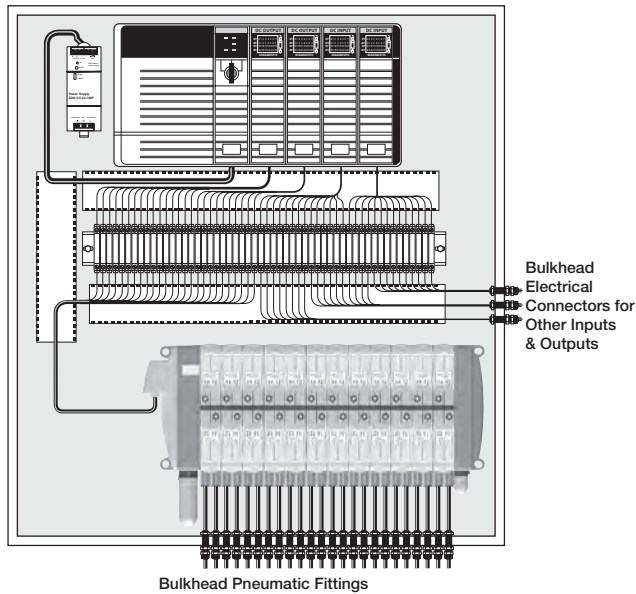

D

Subbase & Manual Valves

H Series Micro

Moduflex Series

H Series ISO

Fieldbus Systems

DX ISOMAX Series

Valvair II Series



For inventory, lead time, and kit lookup, visit www.pdnplu.com

Basic Systems: Moduflex Fieldbus

- Up to 16 solenoids per manifold
- Fieldbus equipped manifolds – optimized for PLCs with fieldbus capability
- Routinely used on medium sized machines
- Connectivity to Moduflex, H Series Micro and H Series ISO valves.

Centralized Application

Valves Inside Control Cabinet

- Valves located near machine control
- Applications with caustic wash down, hazardous areas, or extreme temperatures
- Additional inputs and outputs are not directly attached to valve manifold

Advantages

- Highest degree of environmental protection
- One location for all control devices
- Small size requires minimal cabinet space
- Eliminates terminal strips and wire ways for valves
- Greatly reduces wiring time
- Eliminates junction boxes for valves
- Eliminates conduit runs for valves

Decentralized Application

H Series Micro Outside Control Cabinet

- Valves located near application - Ready for machine mounting
- IP65 rating suitable for dusty and wet environments
- Additional inputs and outputs are not directly attached to valve manifold

Advantages

- Smallest control cabinet
- Reduces tubing length and improves pneumatic response time
- Eliminates pneumatic bulk fittings on control cabinet
- Many fieldbus nodes can be attached to the network with little incremental cost – valve manifolds, inputs, outputs and other devices.
- Eliminates terminal strips and wire ways for valves
- Greatly reduces wiring time
- Eliminates junction boxes for valves
- Eliminates conduit runs for valves

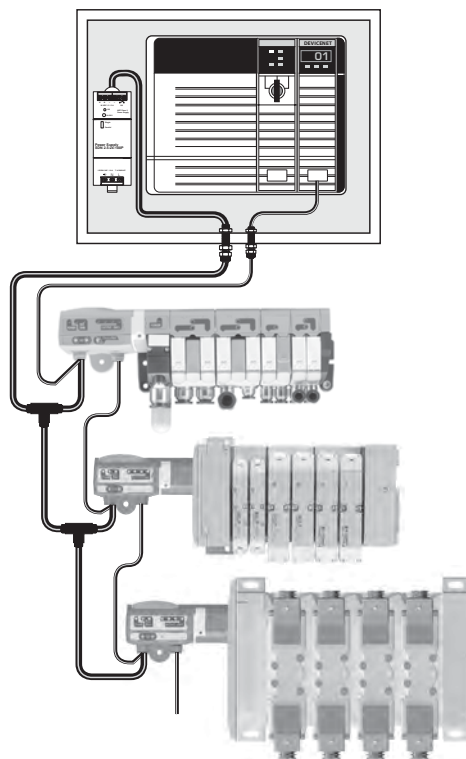
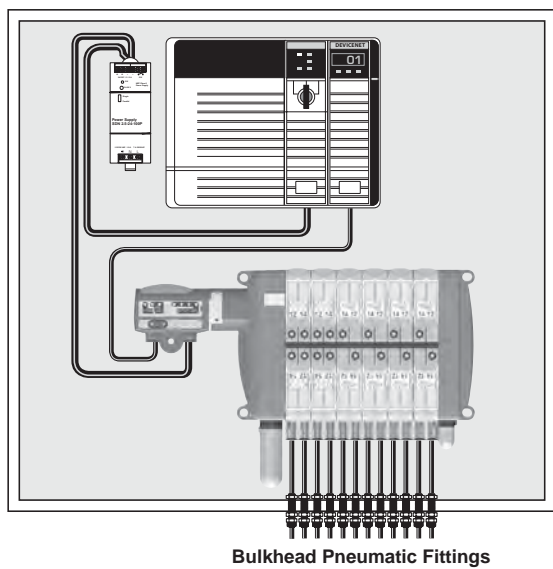

D	Subbase & Manual Valves
H Series Micro	Moduflex Series
H Series ISO	Fieldbus Systems
DX ISOMAX Series	Valvair II Series



For inventory, lead times, and kit lookup, visit www.pdnplu.com

Complete Fieldbus Systems: H Series Fieldbus System

- Up to 32 Solenoids per Manifold
- With H Series Micro Bus Extension Functionality, 4 Manifolds with up to 32 Solenoids each can be connected on the same Node
- Add Inputs and Outputs to the H Series Fieldbus Network
- Fieldbus equipped Manifolds – optimized for PLC's with Fieldbus capability
- Connectivity to H Series Micro and H Series ISO valves

Centralized Application

Valves Inside Control Cabinet

- H Series Fieldbus System with Inputs and Outputs
- Valves located near machine control
- Applications with caustic wash down, hazardous areas, or extreme temperatures
- Additional inputs and outputs are directly attached to valve manifold

Advantages

- Handle All I/O from One Node
- Eliminate PLC Input / Output Cards
- Up to 128 Solenoids per Node with Bus Extension Cables
- Up to 256 Inputs and 256 Outputs per H Series Fieldbus Node
- Analog Inputs / Outputs available
- Highest degree of environmental protection
- One location for all control devices
- Eliminates terminal strips and wire ways
- Greatly reduces wiring time

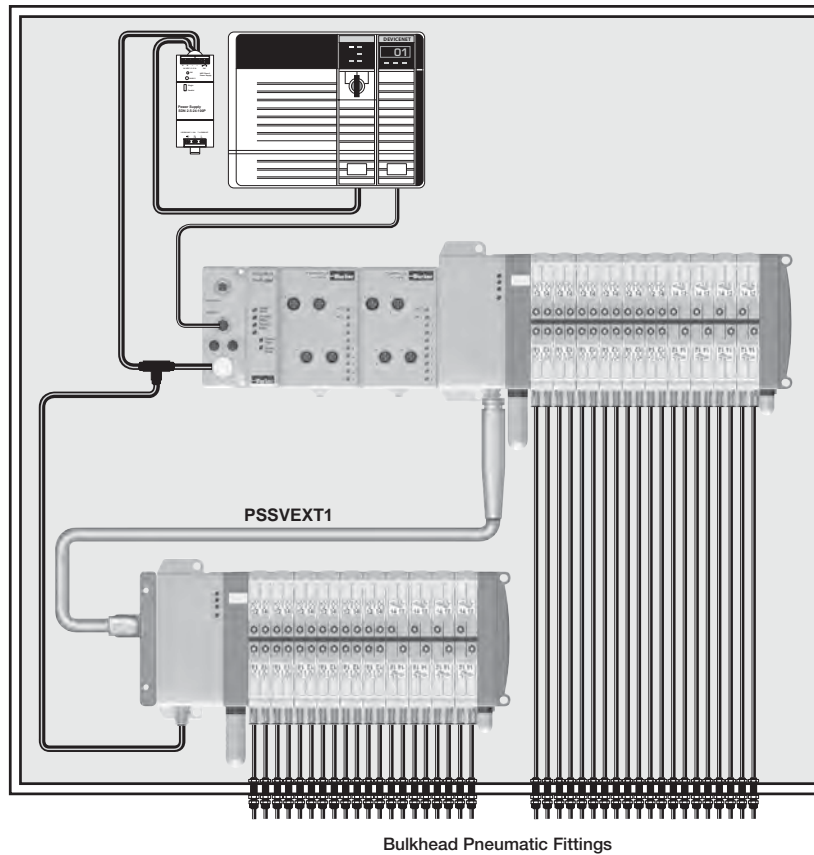

For inventory, lead time, and kit lookup, visit www.pdnplu.com

D191

Parker Hannifin Corporation
 Pneumatic Division
 Richland, Michigan
www.parker.com/pneumatics

D

Subbase & Manual Valves

H Series Micro

Moduflex Series

H Series ISO

Fieldbus Systems

DX ISOMAX Series

Valvair II Series

Complete Fieldbus Systems: H Series Fieldbus System

- Up to 32 Solenoids per Manifold
- With H Series Micro Bus Extension Functionality, 4 Manifolds with up to 32 Solenoids each can be connected on the same Node
- Add Inputs and Outputs to the H Series Fieldbus Network
- Fieldbus equipped Manifolds – optimized for PLC's with Fieldbus capability
- Connectivity to H Series Micro and H Series ISO valves

Decentralized Application

Valves Outside Control Cabinet

- H Series Fieldbus System with Inputs and Outputs
- Valves located near application - Ready for machine mounting
- IP65 rating suitable for dusty and wet environments
- Additional inputs and outputs are directly attached to valve manifold

Advantages

- Handle All I/O from One Node
- Eliminate PLC Input / Output Cards
- Up to 128 Solenoids per Node with Bus Extension Cables
- Up to 256 Inputs and 256 Outputs per H Series Fieldbus Nodes
- Analog Inputs / Outputs available
- Smallest control cabinet
- Reduces tubing length and improves pneumatic response time
- Eliminates pneumatic bulk fittings on control cabinet
- Many fieldbus nodes can be attached to the network with little incremental cost – valve manifolds, inputs, outputs and other devices.
- Eliminates terminal strips and wire ways
- Greatly reduces wiring time
- Eliminates junction boxes for all inputs and outputs
- Eliminates conduit runs for all inputs and outputs

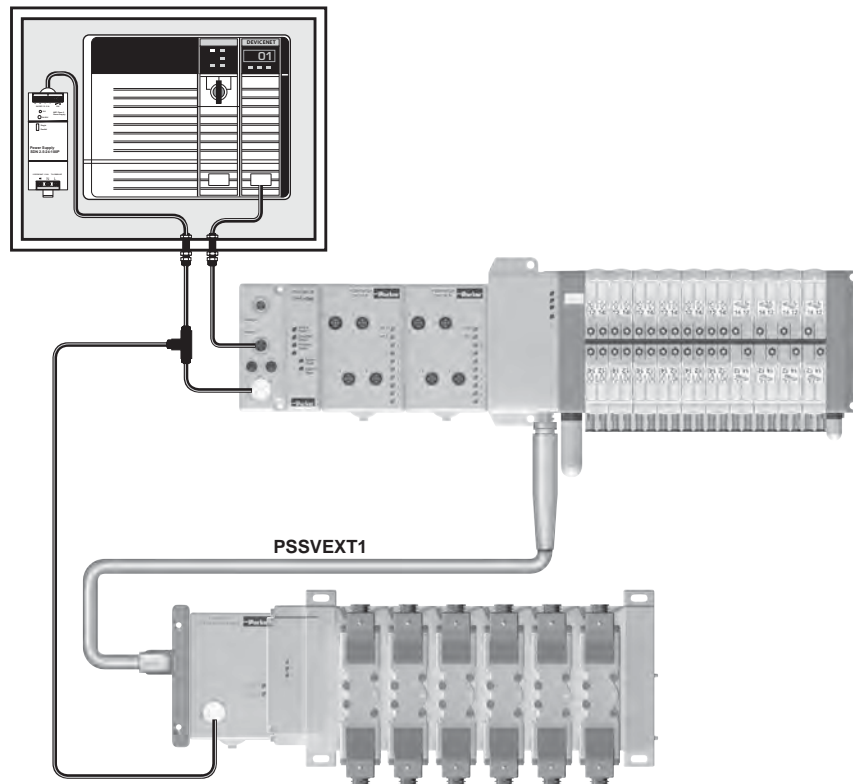

D	Subbase & Manual
Valves	H Series Micro
Modulflex Series	H Series ISO
Fieldbus Systems	DX ISOMAX Series
Valvair II Series	



For inventory, lead times, and kit lookup, visit www.pdnplu.com

Complete Fieldbus Systems: Turck Fieldbus System

General Product Features

- Turck Fieldbus System with up to 256 inputs / outputs and 32 Solenoids per manifold
- Digital inputs / outputs, analog inputs / outputs, serial interface, counter modules, and RFID modules available
- Connectivity to H Series Micro and H Series ISO valves system

Advantages

- Handle all I/O from one node; eliminate PLC input / output cards
- Fieldbus equipped manifolds – optimized for PLC's with fieldbus capability
- Eliminates junction boxes, terminal strips, and conduit runs for all inputs and outputs, greatly reducing wiring time

Centralized Application

Valves Inside Control Cabinet

- Valves located near machine control
- Applications with caustic wash down, hazardous areas, or extreme temperatures

Advantages

- Highest degree of environmental protection
- One location for all control devices
- Small size requires minimal cabinet space

Decentralized Application

Valves Outside Control Cabinet

- Valves located near application - ready for machine mounting
- IP65 rating suitable for dusty and wet environments

Advantages

- Smallest control cabinet
- Reduces tubing length and improves response time
- Eliminates pneumatic bulk fittings on control cabinet



Modbus/TCP™
CANopen

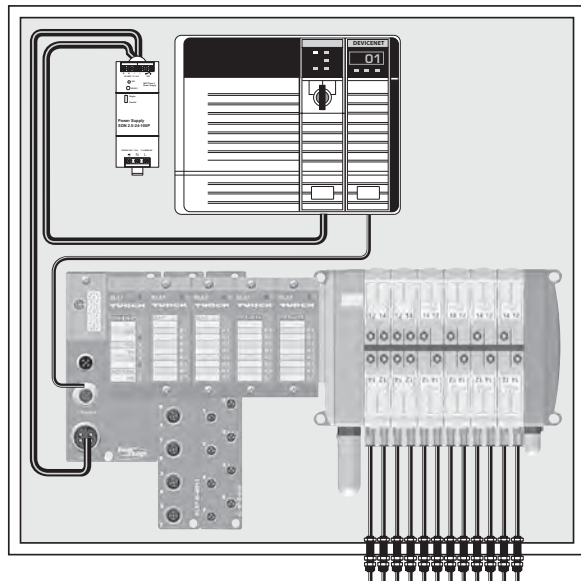

Bulkhead Pneumatic Fittings

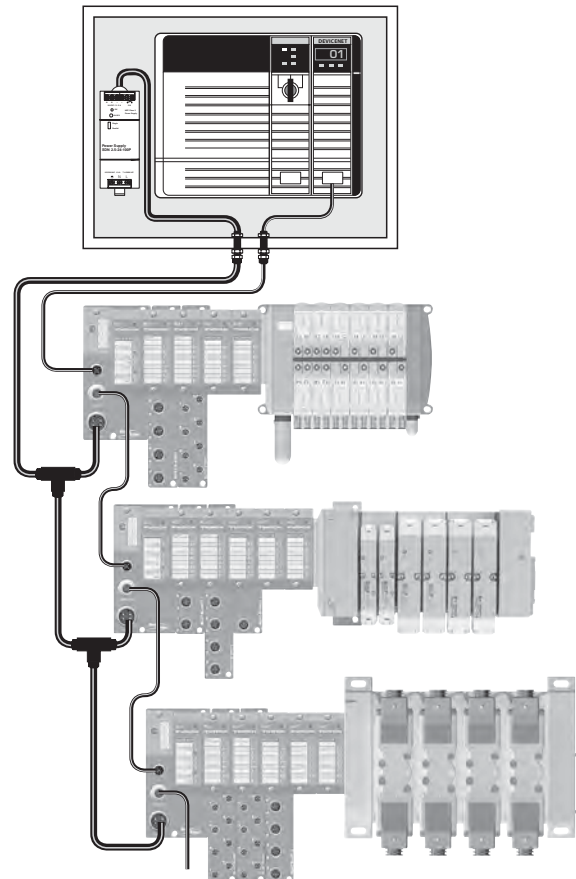

For inventory, lead time, and kit lookup, visit www.pdnplu.com

Complete Fieldbus Systems: Turck Fieldbus System with CANopen Expansion

General Product Features

- Turck Fieldbus System with up to 256 inputs / outputs and 32 Solenoids per manifold
- Digital inputs / outputs, analog inputs / outputs, serial interface, counter modules, and RFID modules available
- Connectivity to H Series Micro and H Series ISO valves

CANopen Expansion Features

- Using a CANopen Interface module, a CANopen subnet is created within the BL67 network, controlling an additional 64 inputs, outputs, or solenoids.
- The CANopen subnet is independent of the main fieldbus network, and is not visible to the master PLC.
- Additional Moduflex CANopen modules can be attached to the CANopen subnet to provide a connection for 16 solenoids each.
- Other 3rd party CANopen devices can also be used on this network, within the 64 bit CANopen Expansion limit.

System Advantages

- Handle all I/O from one node; eliminate PLC input / output cards
- Fieldbus equipped manifolds – optimized for PLC’s with fieldbus capability
- Several CANopen fieldbus nodes can be attached to the network – valve manifolds, inputs, outputs or other devices
- CANopen expansion allows additional devices to be attached to the system without a CANopen scanner card
- Eliminates junction boxes, terminal strips, and conduit runs for all inputs and outputs, greatly reducing wiring time

Centralized Application

Valves Inside Control Cabinet

- Valves located near machine control
- Applications with caustic wash down, hazardous areas, or extreme temperatures

Advantages

- Highest degree of environmental protection
- One location for all control devices
- Small size requires minimal cabinet space

Decentralized Application

Valves Outside Control Cabinet

- Valves located near application - ready for machine mounting
- IP65 rating suitable for dusty and wet environments

Advantages

- Smallest control cabinet
- Reduces tubing length and improves response time
- Eliminates pneumatic bulk fittings on control cabinet

D
 Subbase & Manual Valves
 H Series Micro
 Moduflex Series
 H Series ISO
 Fieldbus Systems
 DX ISOMAX Series
 Valvair II Series

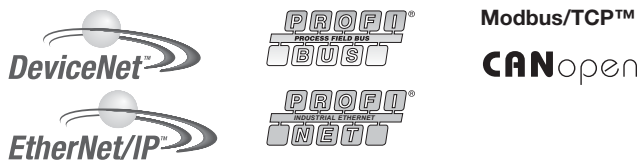

Modbus/TCP™
CANopen

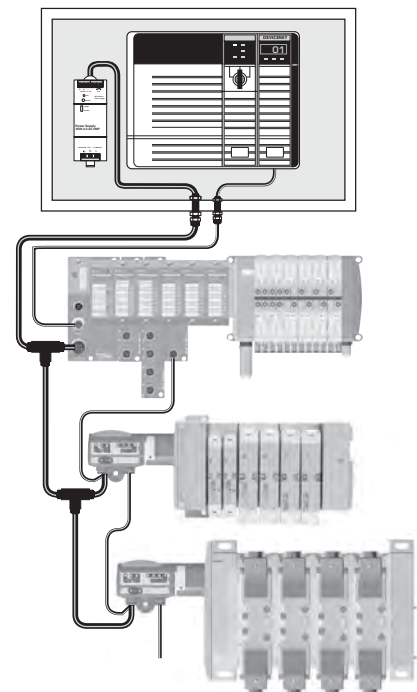
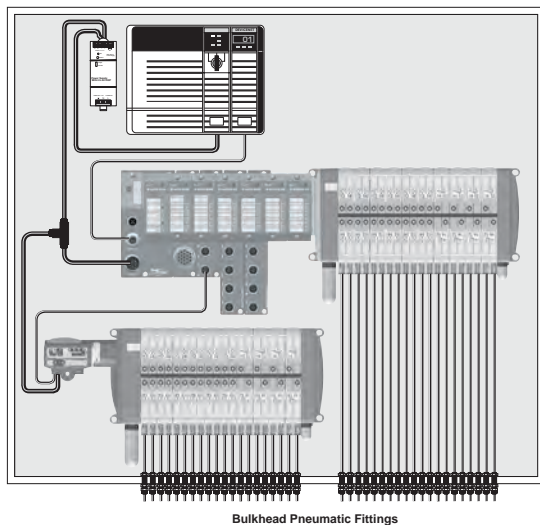

For inventory, lead times, and kit lookup, visit www.pdnplu.com

Complete Fieldbus Systems: Turck Fieldbus System with BL Remote DeviceNet Subnet

General Product Features

- Turck Fieldbus System with up to 256 inputs / outputs and 32 Solenoids per manifold
- Digital inputs / outputs, analog inputs / outputs, serial interface, counter modules, and RFID modules available
- Connectivity to H Series Micro and H Series ISO valves

BL Remote DeviceNet Subnet Features

- With BL Remote DeviceNet Subnet functionality, each communication module has its own DeviceNet master which provides a connection for 63 DeviceNet nodes with additional inputs, outputs, and solenoid control
- BL Remote DeviceNet Subnet is independent of the main fieldbus network, and is not visible to the master PLC
- Moduflex DeviceNet modules can be attached to the subnet to provide a connection for 16 solenoids each
- Turck DeviceNet modules can be attached to the subnet to provide a connection for 16 or 32 solenoids each and inputs and outputs up to the 256 input and output limitation

System Advantages

- Handle all I/O from one node; eliminate PLC input / output cards
- Fieldbus equipped manifolds – optimized for PLC's with fieldbus capability
- Many DeviceNet nodes can be attached to the network – valve manifolds, inputs, outputs or other devices
- Eliminates junction boxes, terminal strips, and conduit runs for all inputs and outputs, greatly reducing wiring time

Centralized Application

Valves Inside Control Cabinet

- Valves located near machine control
- Applications with caustic wash down, hazardous areas, or extreme temperatures

Advantages

- Highest degree of environmental protection
- One location for all control devices
- Small size requires minimal cabinet space

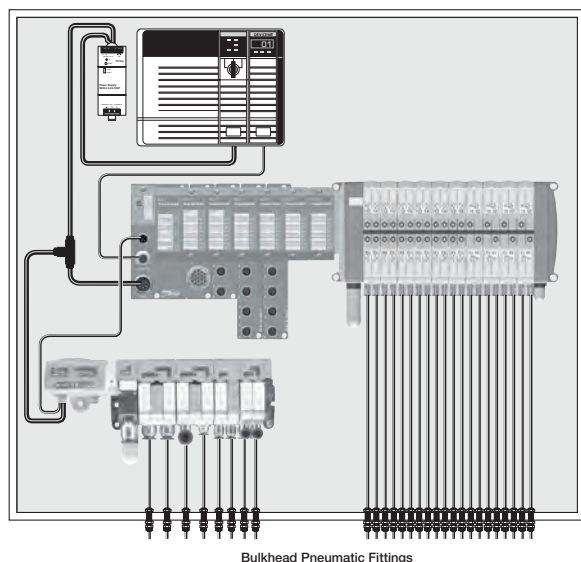

Decentralized Application

Valves Outside Control Cabinet

- Valves located near application, ready for machine mounting
- IP65 rating suitable for dusty and wet environments

Advantages

- Smallest control cabinet
- Reduces tubing length and improves response time
- Eliminates pneumatic bulk fittings on control cabinet

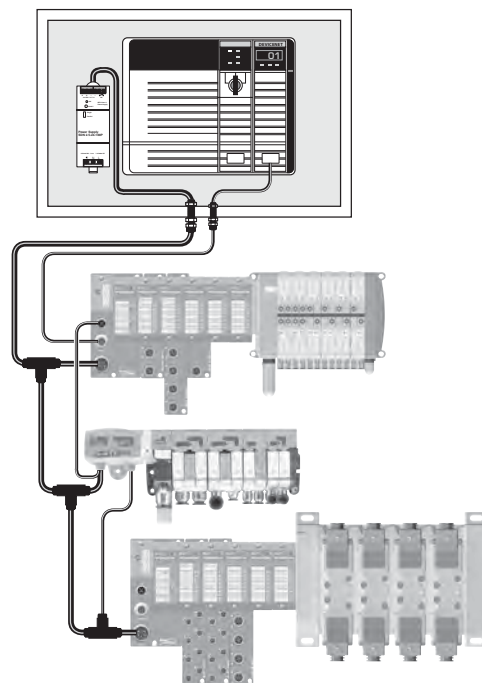

Complete Fieldbus Systems: Turck Fieldbus System with Stand Alone Control

General Product Features

- Turck Fieldbus System with up to 256 inputs / outputs and 32 Solenoids per manifold
- Digital inputs / outputs, analog inputs / outputs, serial interface, counter modules, and RFID modules available
- Connectivity to H Series Micro and H Series ISO valves

Stand Alone Control Features

- Communication modules equipped with standalone control – programmed according to IEC61131-3 with CoDeSys
- 512KB Program memory with 32 bit RISC processor
- Run 1000 instructions in less than 1 ms
- Fieldbus equipped manifolds – optimized for PLC’s with fieldbus capability or standalone controllers that need to interface with other devices

System Advantages

- Handle all I/O and control with one system; eliminate the PLC when used as the main controller for smaller machines
- Reduces programming and bandwidth requirements on large machines with a master PLC controller by handling local I/O and interfacing with the PLC over the fieldbus network
- Fieldbus equipped manifolds provide connectivity to other fieldbus devices
- Eliminates junction boxes, terminal strips, and conduit runs for all inputs and outputs, greatly reducing wiring time

Centralized Application Valves

Inside Control Cabinet

- Valves attached to the machine control
- Applications with caustic wash down, hazardous areas, or extreme temperatures

Advantages

- Highest degree of environmental protection
- One location for all control devices

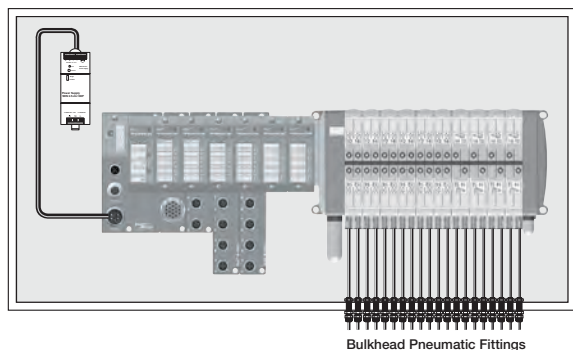

Decentralized Application

Valves Outside Control Cabinet

- Valves and machine control located near application, ready for machine mounting
- IP65 rating suitable for dusty and wet environments

Advantages

- No control cabinet needed when used as the main controller
- Reduces tubing length and improves response time
- Eliminates pneumatic bulk fittings on control cabinet

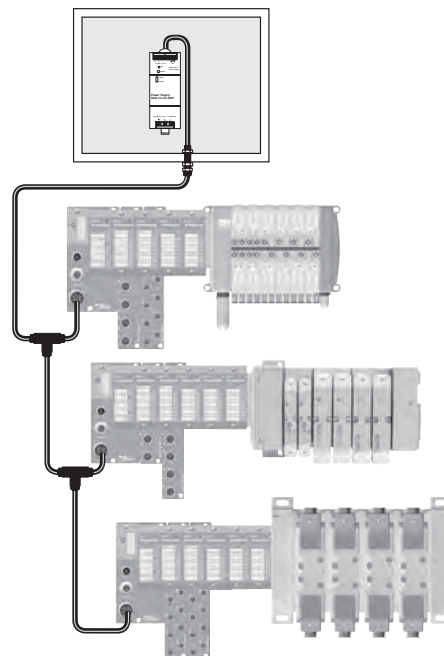

D	Subbase & Manual Valves
	H Series Micro
	Modutlex Series
	H Series ISO
	Fieldbus Systems
	DX ISOMAX Series
	Valvair II Series



For inventory, lead times, and kit lookup, visit www.pdnplu.com

H Series Fieldbus with H Series ISO Valves

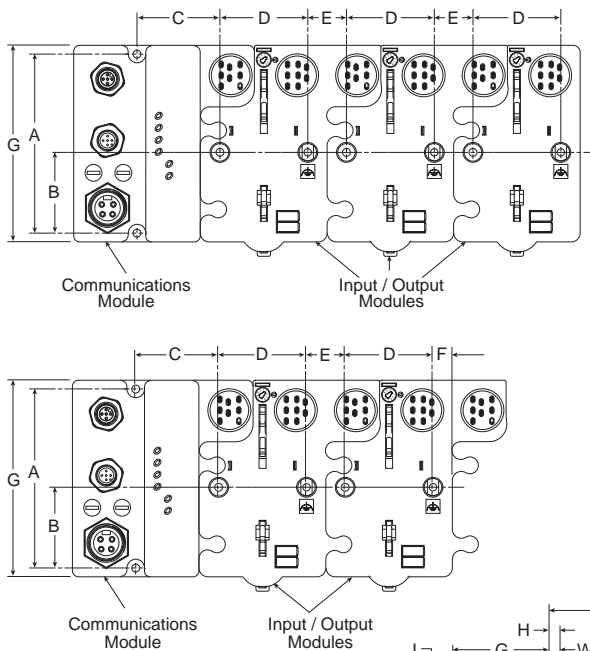

Dimensions

A	B	C	D
4.00 (102)	1.80 (46)	1.90 (48)	2.00 (50)
E	F	G	
.87 (22)	.43 (11)	4.41 (112)	

Inches (mm)

HB - HA Dimensions

G	H	H ₁	J	K
2.68 (68)	.33 (8.4)	1.80 (45.8)	.15 (4)	4.32 (110)
L	M	P	W	W ₁
.63 (16)	5.39 (137)	5.98 (152)	1.61 (40.8)	2.24 (56.8)

Inches (mm)

H1 Dimensions

G	H	J	K	P
2.20 (56)	.63 (15.9)	.33 (8.5)	6.50 (165)	7.17 (182)
W				
1.93 (49)				

Inches (mm)

H2 Dimensions

G	H	J	K	P
2.28 (58)	.63 (16)	.47 (12)	8.46 (215)	9.41 (239)
W				
2.20 (56)				

Inches (mm)

H3 Dimensions

G	H	J	K	P
2.52 (64)	.65 (16.5)	.59 (15)	10.43 (265)	11.61 (295)
W				
2.80 (71)				

Inches (mm)

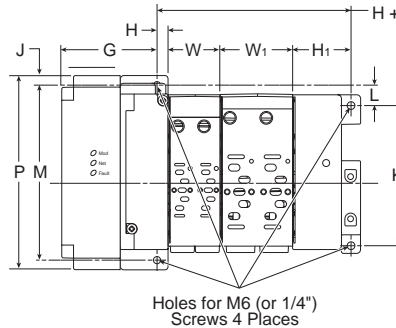

$H + H_1 + (W \times n + W_1 \times n_1)$
 n = Number of 18mm HB Bases
 n₁ = Number of 26mm HA Bases
 W = Width of 18mm HB Bases
 W₁ = Width of 26mm HA Bases

HB - HA Manifold Assembly

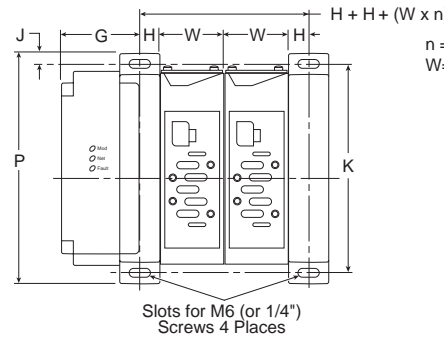

$H + H + (W \times n)$
 n = Number of H1 Bases
 W = Width of H1 Bases

H1 Manifold Assembly

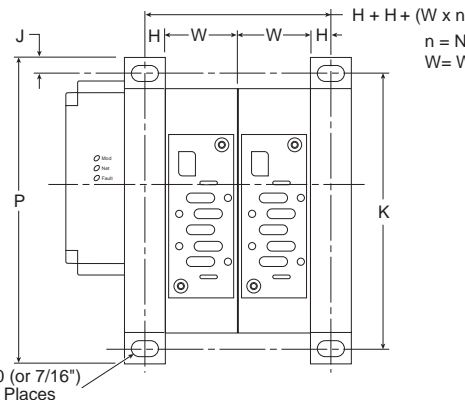

$H + H + (W \times n)$
 n = Number of H2 / H3 Bases
 W = Width of H2 / H3 Bases

H2 - H3 Manifold Assembly

D

Subbase & Manual Valves

H Series Micro

Moduflex Series

H Series ISO

Fieldbus Systems

DX ISOMAX Series

Valvair II Series



For inventory, lead time, and kit lookup, visit www.pdnplu.com

H Series Fieldbus with H Series ISO Valves

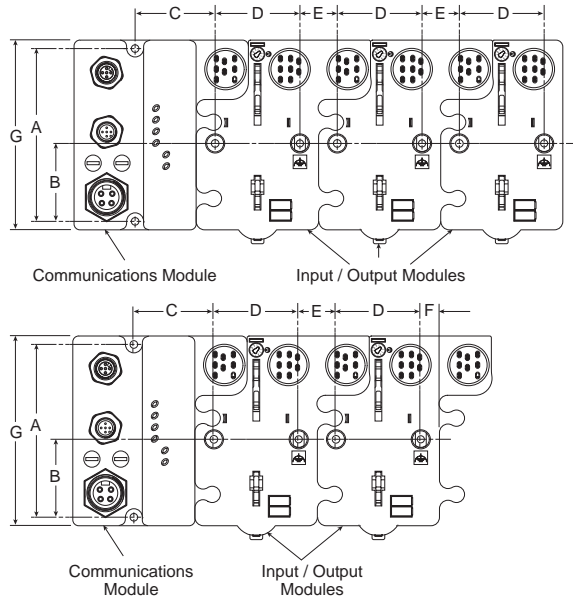

A	B	C	D
4.00 (102)	1.80 (46)	1.90 (48)	2.00 (50)

E	F	G
.87 (22)	.43 (11)	4.41 (112)

Inches (mm)

D Subbase & Manual Valves
 H Series Micro
 Modulflex Series
 H Series ISO
 Fieldbus Systems
 DX ISOMAX Series
 Valvair II Series

HB - HA Manifold Assembly

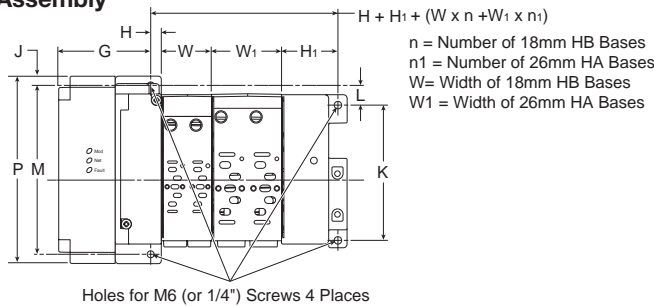

HB - HA Dimensions

G	H	H₁	J	K
2.68 (68)	.33 (8.4)	1.80 (45.8)	.15 (4)	4.32 (110)

L	M	P	W	W₁
.63 (16)	5.39 (137)	5.98 (152)	1.61 (40.8)	2.24 (56.8)

Inches (mm)

H1 Manifold Assembly

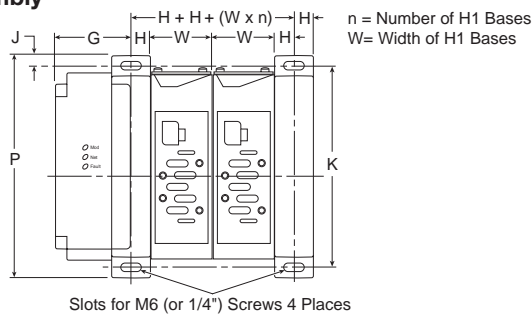

H1 Dimensions

G	H	J	K	P
2.20 (56)	.63 (15.9)	.33 (8.5)	6.50 (165)	7.17 (182)

W
1.93 (49)

Inches (mm)

H2 Dimensions

G	H	J	K	P
2.34 (59.5)	.65 (16.5)	.47 (12)	8.46 (215)	9.41 (239)

W
2.20 (56)

Inches (mm)

H3 Dimensions

G	H	J	K	P
2.34 (59.5)	.65 (16.5)	.59 (15)	10.43 (265)	11.61 (295)

W
2.80 (71)

Inches (mm)

H2 - H3 Manifold Assembly

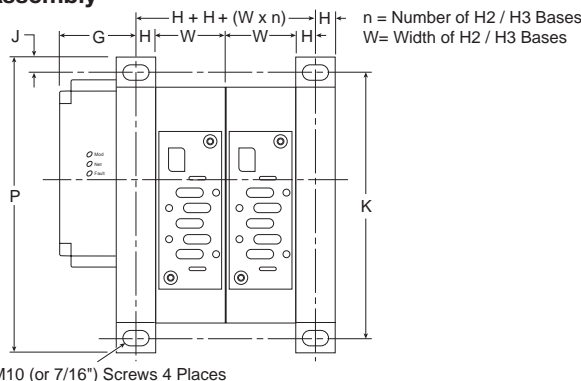

For inventory, lead times, and kit lookup, visit www.pdnplu.com

Turck with H Series ISO Valves

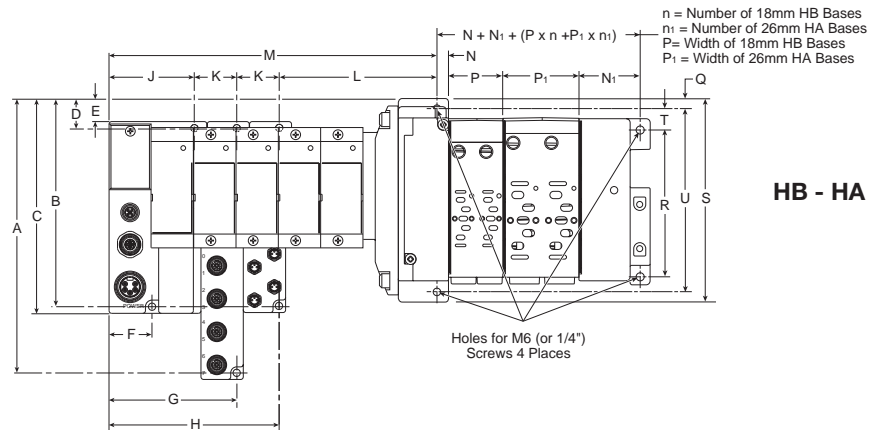

HB - HA Manifold Assembly

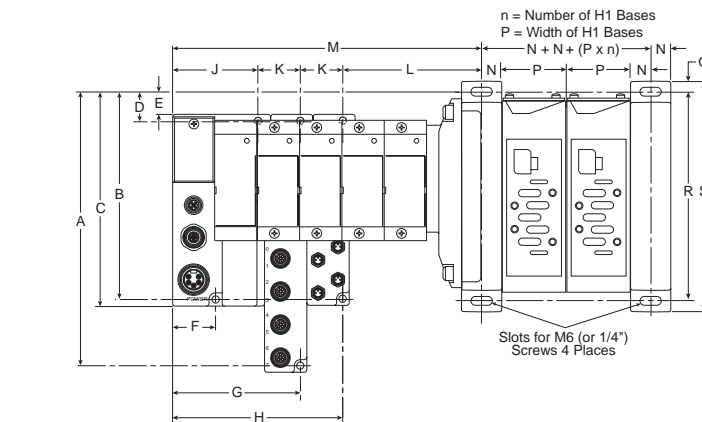

H1 Manifold Assembly

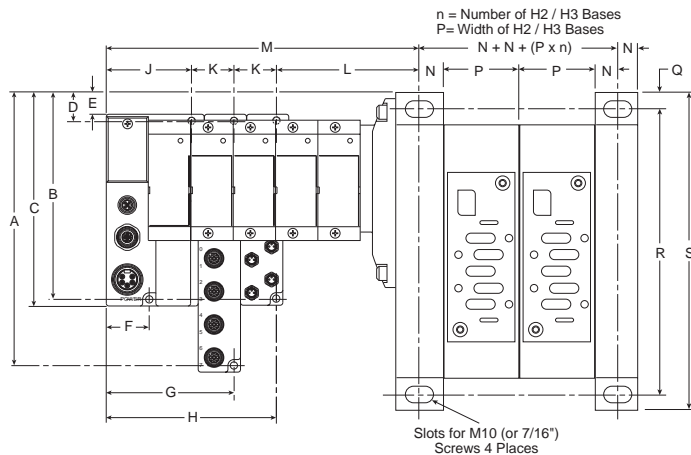

H2 - H3 Manifold Assembly

	A	B	C	D	E	F	G	H	J	K	L	M	N	N ₁	P	P ₁	Q	R	S	T	U
HA / HB	8.05 (204.5)	6.08 (154.5)	6.28 (159.5)	0.75 (19.5)	0.57 (14.5)	1.28 (32.5)	3.79 (96.5)	5.06 (128.5)	2.53 (64.5)	1.26 (32)	4.75 (120.8)	See note 1	.33 (8.4)	1.80 (45.8)	1.61 (40.8)	2.24 (56.8)	.15 (4)	4.32 (110)	5.98 (152)	.63 (16)	5.39 (137)
H1	8.53 (216.7)	6.56 (166.7)	6.76 (171.7)	1.25 (31.7)	1.05 (26.7)	1.28 (32.5)	3.79 (96.5)	5.06 (128.5)	2.53 (64.5)	1.26 (32)	4.27 (108.5)	See note 1	.63 (15.9)	—	1.93 (49)	—	.33 (8.5)	6.50 (165)	7.17 (182)	—	—
H2	8.38 (212.9)	6.41 (162.9)	6.61 (167.9)	1.10 (27.9)	.90 (22.9)	1.28 (32.5)	3.79 (96.5)	5.06 (128.5)	2.53 (64.5)	1.26 (32)	4.34 (110)	See note 1	.65 (16.5)	—	2.20 (56)	—	.47 (12)	8.46 (215)	9.41 (239)	—	—
H3	8.62 (218.9)	6.65 (168.9)	6.85 (173.9)	1.33 (33.9)	1.14 (28.9)	1.28 (32.5)	3.79 (96.5)	5.06 (128.5)	2.53 (64.5)	1.26 (32)	4.34 (110)	See note 1	.65 (16.5)	—	2.80 (71)	—	.59 (15)	10.43 (265)	11.61 (295)	—	—

Note 1: $M = J + L + n_2 \times K$, where n_2 = Number of Turck input / output modules
 Inches (mm)



For inventory, lead time, and kit lookup, visit www.pdnplu.com

D199

Parker Hannifin Corporation
 Pneumatic Division
 Richland, Michigan
www.parker.com/pneumatics

D

Subbase & Manual Valves

H Series Micro

Modulflex Series

H Series ISO

Fieldbus Systems

DX ISOMAX Series

Valvair II Series

Turk with H Series Micro Valves

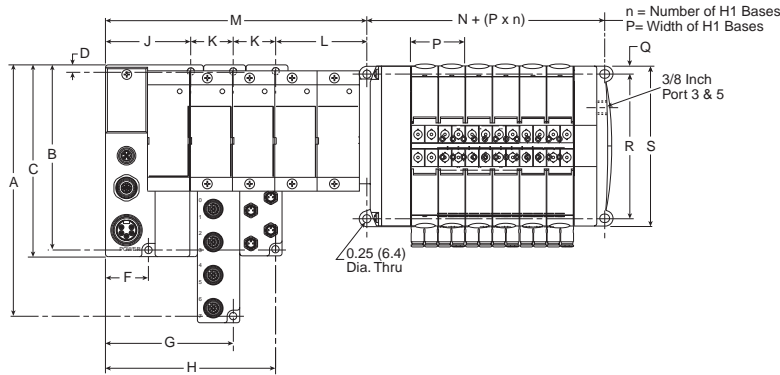

A	B	C	D	F	G	H	J	K	L	M	N	P	Q	R	S
7.48	5.51	5.71	0.20	1.28	3.79	5.06	2.53	1.26	2.54	See note 1	2.28	1.65	.19	4.41	4.88
(190)	(140)	(145)	(5)	(32.5)	(96.5)	(128.5)	(64.5)	(32)	(64)		(58)	(42)	(4.9)	(112)	(124)

Note 1: $M = J + L + n_2 \times K$, where n_2 = Number of Turk input / output modules
 Inches (mm)

D
 Subbase & Manual Valves
 H Series Micro
 Moduflex Series
 H Series ISO
 Fieldbus Systems
 DX ISOMAX Series
 Valvair II Series

Moduflex Adapter, Side Ported

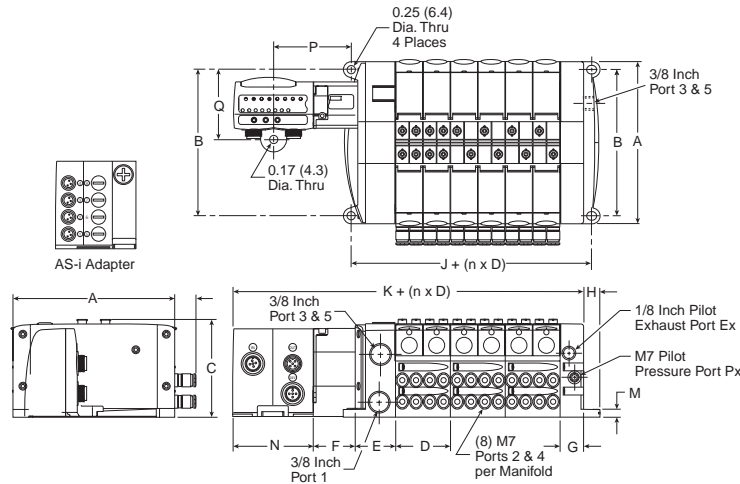

A	B	C	D	E	F	G	H	J	K	M	N	P	Q
4.88	4.41	2.95	1.65	1.22	1.28	0.71	0.49	2.28	6.10	0.24	2.40	2.36	2.07
(124.0)	(112.0)	(75.0)	(42.0)	(31.0)	(32.5)	(18.0)	(12.5)	(58.0)	(155.0)	(6.1)	(61.0)	(60.0)	(52.5)

Inches (mm)



For inventory, lead times, and kit lookup, visit www.pdnplu.com

D200

Parker Hannifin Corporation
 Pneumatic Division
 Richland, Michigan
www.parker.com/pneumatics

H Series Fieldbus with H Series Micro Valves

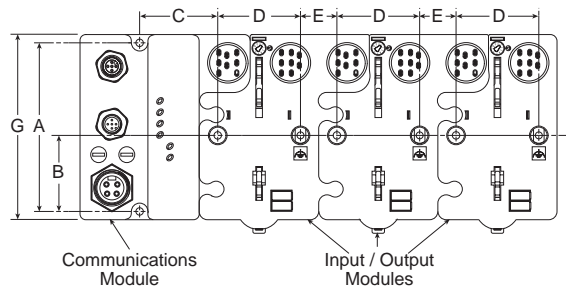

A	B	C	D
4.00 (102)	1.80 (46)	1.90 (48)	2.00 (50)
E	F	G	
.87 (22)	.43 (11)	4.41 (112)	

Inches (mm)

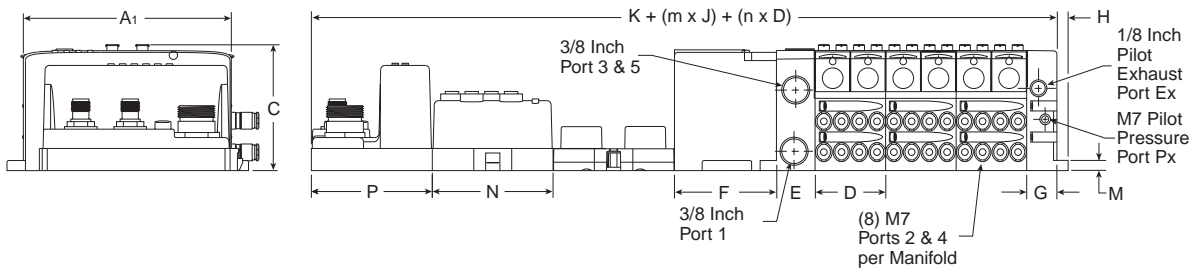
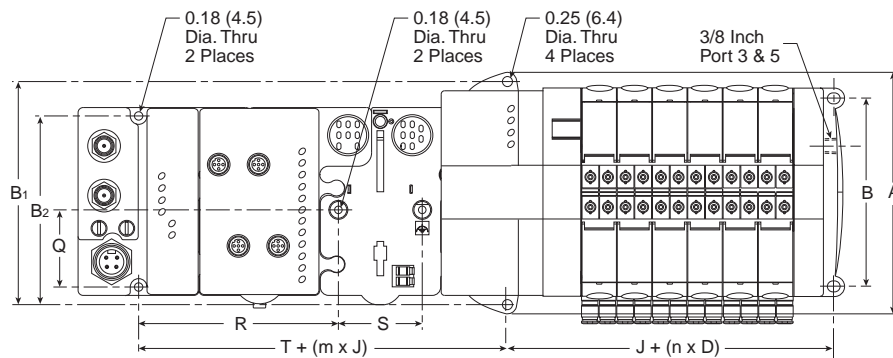
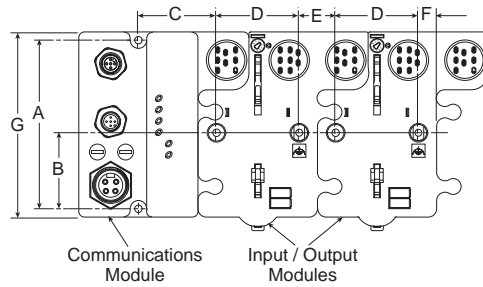

A	A ₁	B	B ₁	B ₂	C	D	E	F	G
5.67 (144.0)	4.88 (124.0)	4.41 (112.0)	5.24 (133.0)	4.02 (102.0)	2.95 (75.0)	1.65 (42.0)	0.91 (23.0)	2.40 (61.0)	0.71 (18.0)
H	J	K	M	N	P	Q	R	S	T
0.49 (12.5)	2.72 (69.0)	7.32 (186.0)	0.24 (6.1)	2.83 (72.0)	2.83 (72.0)	1.81 (46.0)	4.72 (120.0)	2.01 (51.0)	2.01 (51.0)

Inches (mm)

n = Number of Manifolds
 m = Number of Modules



For inventory, lead time, and kit lookup, visit www.pdnplu.com

D201

Parker Hannifin Corporation
 Pneumatic Division
 Richland, Michigan
www.parker.com/pneumatics

D

Subbase & Manual Valves

H Series Micro

Modulflex Series

H Series ISO

Fieldbus Systems

DX ISOMAX Series

Valvair II Series

Moduflex with H Series ISO Valves

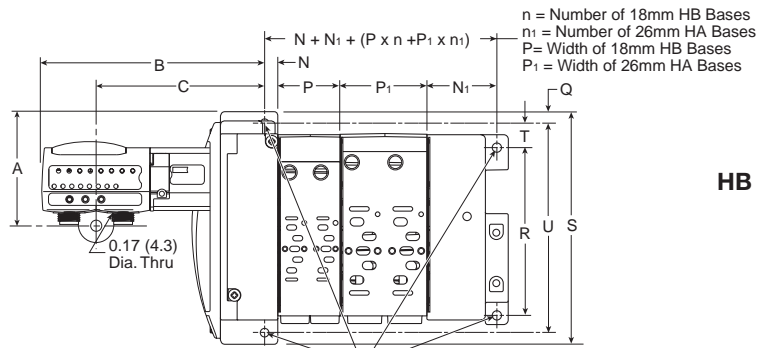

HB - HA Manifold Assembly

Holes for M6 (or 1/4")
 Screws 4 Places

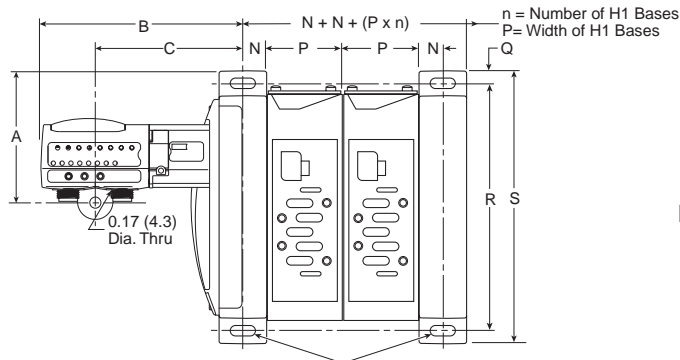

H1 Manifold Assembly

Slots for M6 (or 1/4")
 Screws 4 Places

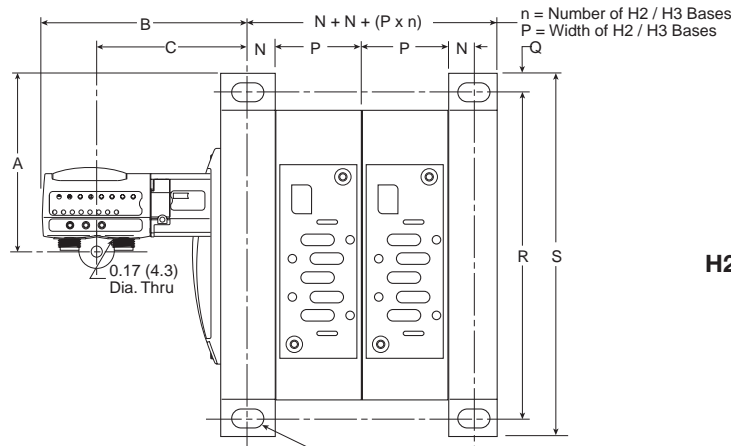

H2 - H3 Manifold Assembly

Slots for M10 (or 7/16")
 Screws 4 Places

	A	B	C	N	N ₁	P	P ₁	Q	R	S	T	U
HA / HB	2.75 (69.8)	5.61 (142.5)	4.40 (111.8)	.33 (8.4)	1.80 (45.8)	1.61 (40.8)	2.24 (56.8)	.15 (4)	4.32 (110)	5.98 (152)	.63 (16)	5.39 (137)
H1	3.23 (82)	6.33 (160.9)	5.13 (130.2)	.63 (15.9)	—	1.93 (49)	—	.33 (8.5)	6.50 (165)	7.17 (182)	—	—
H2	3.08 (78.2)	6.40 (161.5)	5.19 (131.8)	.65 (16.5)	—	2.20 (56)	—	.47 (12)	8.46 (215)	9.41 (239)	—	—
H3	3.31 (84.2)	6.40 (161.5)	5.19 (131.8)	.65 (16.5)	—	2.80 (71)	—	.59 (15)	10.43 (265)	11.61 (295)	—	—

Inches (mm)

D
 Subbase & Manual Valves
 H Series Micro
 Moduflex Series
 H Series ISO
 Fieldbus Systems
 DX ISOMAX Series
 Valvair II Series



For inventory, lead times, and kit lookup, visit www.pdnplu.com

D202

Parker Hannifin Corporation
 Pneumatic Division
 Richland, Michigan
www.parker.com/pneumatics

DX ISOMAX Series

The ISOMAX range of directional control valves complies with ISO 15407-1 and VDMA 24563 for sizes 02 and 01 and ISO 5599-1 for sizes 1, 2 and 3. ISOMAX provides flows from 0.55 Cv to 4.15 Cv.

The ISOMAX range includes valves for pneumatic and electrical actuation with a wide choice of subbases and manifolds to suit different application needs.

All ISOMAX products use high-tech ceramic switching technology providing:

Excellent reliability

- Long life in excess of 100 million operations*
- Operates with lubricated or non-lubricated air
- Low sensitivity to air quality changes

High performance

- Slide valve concept allows high flow / size ratio and short response time due to short slide stroke and low friction

Stable long lasting performances

- Low friction switching: minimum wear of the valve member / seal assembly

Valves fitted with switchable selector to give internal or external pilot supply

Corrosion free and modern design

Vacuum operation

Dual pressure

* Refer to our warranty conditions.

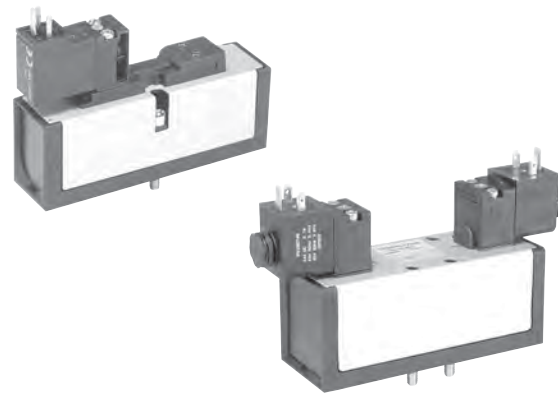

Operating information

Operating Pressure: Vacuum to 145 PSIG (10 bar)

Function		M.O.P (PSIG)
20, 21, 22, 23	2-position, spring return	36
50, 51, 53, 54	2-position, air return	30
04, 05, 06, 08	2-position	15
09, 11, 12, 27	3-position, CE	45
16, 18, 19, 25	3-position, APB	45

Working temperatures: -10°C to 60°C (14°F to 140°F)

Storage temperatures: -20°C to 70°C (-4°F to 158°F)

Material specifications

Body	Polyamide reinforced fiberglass
Casing	Anodized aluminum
End plates	Painted zinc plated steel
Function selector	Polyamide reinforced fiberglass
Screws	Zinc plated steel
Seals	Nitrile
Seat	Ceramic
Springs	Stainless steel
Top cover seals	Polyester
Valve members	Self lubricating acetal
Valve plate	Zinc

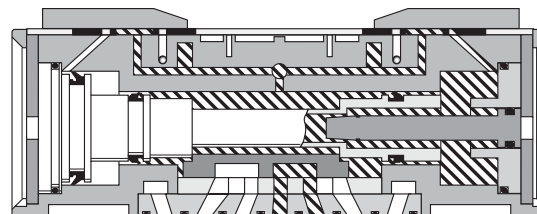
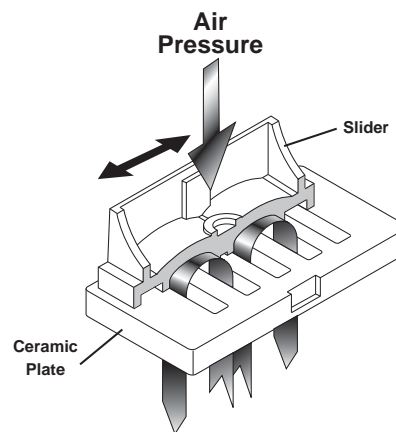
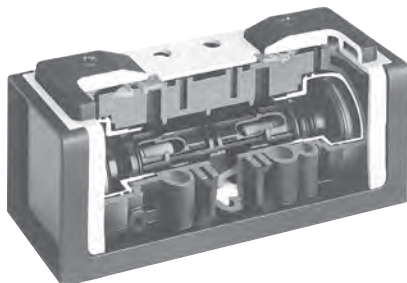

Pressure Exhaust

Remote Pilot



For inventory, lead time, and kit lookup, visit www.pdnplu.com

D203

Parker Hannifin Corporation
Pneumatic Division
Richland, Michigan
www.parker.com/pneumatics

D

Subbase & Manual Valves

H Series Micro

Moduflex Series



H Series ISO

Fieldbus Systems



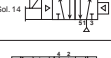
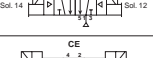
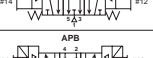

DX ISOMAX Series

Valvair II Series

DX02 ISO Solenoid Valves



Symbol	Type	Cv	Operator	Pilot	Override	24 VDC	120 VAC
	4-way, 2-position, spring return	0.55	Single solenoid	Internal	Non-locking	DX02-621-951M	DX02-621-951J
	4-way, 2-position, air return	0.55	Single solenoid	Internal	Non-locking	DX02-651-951M	DX02-651-951J
	4-way, 2-position	0.55	Double solenoid	Internal	Non-locking	DX02-606-951M	DX02-606-951J
	4-way, 3-position, center exhaust	0.4	Double solenoid	Internal	Non-locking	DX02-611-951M	DX02-611-951J
	4-way, 3-position, all ports blocked	0.4	Double solenoid	Internal	Non-locking	DX02-616-951M	DX02-616-951J

DX02 ISO Remote Pilot Valves

Symbol	Type	Cv	Operator	Pilot	Part number
	4-way, 2-position, spring return	0.55	Single remote pilot	Remote	DX02-421-60
	4-way, 2-position, air return	0.55	Single remote pilot	Remote	DX02-451-60
	4-way, 2-position	0.55	Double remote pilot	Remote	DX02-406-60
	4-way, 3-position, center exhaust	0.4	Double remote pilot	Remote	DX02-411-60
	4-way, 3-position, all ports blocked	0.4	Double remote pilot	Remote	DX02-416-60

Torque Specifications
DX02: 15 to 25 in-lbs (1.69 to 2.82 Nm)
DX01: 20 to 30 in-lbs (2.26 to 3.39 Nm)

DX02 Series Accessories

Accessory	Description	Part number
Sandwich regulator 	Common pressure	2-60 PSIG w/ gauge PS5637155DXP
	Common pressure	5-125 PSIG w/ gauge PS5637166DXP
	Independent pressure	2-60 PSIG w/ gauge PS5637255DXP
	Independent pressure	5-125 PSIG w/ gauge PS5637266DXP
Gauge adapter kit	Includes 1/8" coupling and long nipple	PS5651160P
Sandwich supply module	1/8" NPT	PS562600P
	1/8" BSPP	PS562601P
Sandwich exhaust module	1/8" NPT	PS562700P
	1/8" BSPP	PS562701P
2 Station manifold bases 	Description	1/8" NPT
	End ported bases	PS5611510P PS5611520P
End plate kit 	Description	NPT port
	Non-collective wiring end plate	PS5631010P PS5631011P

 Most popular.



For inventory, lead times, and kit lookup, visit www.pdnplu.com

D204

Parker Hannifin Corporation
Pneumatic Division
Richland, Michigan
www.parker.com/pneumatics

D
 Subbase & Manifold Valves
 H Series Micro
 Moduteflex Series
 H Series ISO
 Fieldbus Systems
 DX ISOMAX Series
 Valvair II Series

DX01 ISO Solenoid Valves

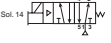
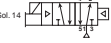
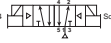
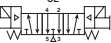
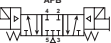

Symbol	Type	Cv	Operator	Pilot	Override	24 VDC	120 VAC
 Sol. 14	4-way, 2-position, spring return	0.75	Single solenoid	Internal	Non-locking	DX01-621-951M	DX01-621-951J
 Sol. 14	4-way, 2-position, air return	0.75	Single solenoid	Internal	Non-locking	DX01-651-951M	DX01-651-951J
 Sol. 14	4-way, 2-position	0.75	Double solenoid	Internal	Non-locking	DX01-606-951M	DX01-606-951J
 Sol. 14	4-way, 3-position, center exhaust	0.5	Double solenoid	Internal	Non-locking	DX01-611-951M	DX01-611-951J
 Sol. 14	4-way, 3-position, all ports blocked	0.5	Double solenoid	Internal	Non-locking	DX01-616-951M	DX01-616-951J

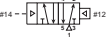
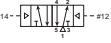
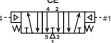
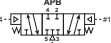
DX01 ISO Remote Pilot Valves

Symbol	Type	Cv	Operator	Pilot	Part number
 #14	4-way, 2-position, spring return	0.75	Single remote pilot	Remote	DX01-421-60
 #14	4-way, 2-position, air return	0.75	Single remote pilot	Remote	DX01-451-60
 #14	4-way, 2-position	0.75	Double remote pilot	Remote	DX01-406-60
 #14	4-way, 3-position, center exhaust	0.5	Double remote pilot	Remote	DX01-411-60
 #14	4-way, 3-position, all ports blocked	0.5	Double remote pilot	Remote	DX01-416-60

Torque Specifications
 DX02: 15 to 25 in-lbs (1.69 to 2.82 Nm)
 DX01: 20 to 30 in-lbs (2.26 to 3.39 Nm)

DX01 Series Accessories

Accessory	Description	Part number
Sandwich regulator 	Common pressure	2-60 PSIG w/ gauge PS5537155DXP
	Common pressure	5-125 PSIG w/ gauge PS5537166DXP
	Independent pressure	2-60 PSIG w/ gauge PS5537255DXP
	Independent pressure	5-125 PSIG w/ gauge PS5537266DXP
Gauge adapter kit	Includes 1/8" coupling and long nipple	PS5651160P
Remote pilot access plate kit	1/4" NPT	PS551500P
	1/4" BSPP	PS551501P
Sandwich supply module	1/4" NPT	PS552600P
	1/4" BSPP	PS552601P
Sandwich exhaust module	1/4" NPT	PS552700P
	1/4" BSPP	PS552701P
Manifold to manifold gasket kits	Used with manifold PJLP02	DX01M2MGSKT
Manifold hardware kit	Includes 10 bolts, 10 washers, 10 nuts	DX02M2MB
2 Station manifold bases 	Description	1/4" NPT 1/4" BSPP
	End ported bases	PS5511530P PS5511540P
End plate kit 	Description	NPT port BSPP port
	Non-collective wiring end plate	PS5631010P PS5531011P

 Most popular.



For inventory, lead time, and kit lookup, visit www.pdnplu.com

D205

Parker Hannifin Corporation
 Pneumatic Division
 Richland, Michigan
www.parker.com/pneumatics

D

Subbase & Manual Valves

H Series Micro

Modulflex Series

H Series ISO

Fieldbus Systems

DX ISOMAX Series

Valvair II Series

Model Number

DX02 - 6 06 - 95 1 M

Basic Series	
ISO 15407-1 (18mm)	DX02
ISO 15407-1 (26mm)	DX01

Pilot	
Air Operated Remote Pilot	4
Solenoid Operated	6

Voltage & Frequency			
	AC		DC
	60Hz	50Hz	
J	120	110	
M			24
Blank	Remote Pilot		

Function	
Internal Pilot Supply / Captured Exhaust 12	
2-Position, Spring Return	21
2-Position, Air Return	51
2-Position	06
3-Position, CE	11
3-Position, APB	16
External Pilot 14 Supply / Captured Exhaust 12*	
2-Position, Spring Return	23
2-Position, Air Return	54
2-Position	05
3-Position, CE	09
3-Position, APB	19
Internal Pilot Supply / Vented Exhaust	
2-Position, Spring Return	20
2-Position, Air Return	50
2-Position	04
3-Position, CE	27
3-Position, APB	25
External Pilot Supply / Vented Exhaust*	
2-Position, Spring Return	22
2-Position, Air Return	53
2-Position	08
3-Position, CE	12
3-Position, APB	18

Override	
Blank	Remote Pilot
1	Non-Locking, Flush
3	Locking, Flush

Operator	
60	None, Remote Pilot Valve
95	15mm, 3-Pin, DIN 43650C

* Must be specified when using Sandwich Regulators.

Note: DX02 18mm Valve Remote Pilot Option only available with PL02 Individual Subbase Kits

- D
- Subbase & Manual Valves
- H Series Micro
- Modulflex Series
- H Series ISO
- Fieldbus Systems
- DX ISOMAX Series
- Valvair II Series



For inventory, lead times, and kit lookup, visit www.pdnplu.com

D206

Parker Hannifin Corporation
 Pneumatic Division
 Richland, Michigan
www.parker.com/pneumatics

15407-1, DX02 & DX01 Manifold / Subbase Kits

PS5511 13 0 P

Basic Series	
ISO 15407-1 DX02	PS5611
ISO 15407-1 DX01	PS5511

Enclosures / Lead Length	
0	None, No Electrical Plug - 15407-1

Mounting Style / Port Size	
DX02	
Manifold with 1/8 NPT End Ports	51
Manifold with 1/8 BSPP End Port	52
Manifold with 1/8 NPT Bottom / End Port	61
Manifold with 1/8 BSPP Bottom / End Port	62
DX01	
Subbase with 1/4 NPT Side Ports	13
Subbase with 1/4 BSPP Side Ports	14
Subbase with 1/4 NPT Bottom / Side Port	23
Subbase with 1/4 BSPP Bottom / Side Port	24
Manifold with 1/4 NPT End Port	53
Manifold with 1/4 BSPP End Port	54
Manifold with 1/4 NPT Bottom / End Port	63
Manifold with 1/4 BSPP Bottom / End Port	64

Subbase Kits

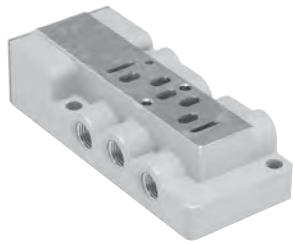

DX01 Series Subbase

Manifold Kits

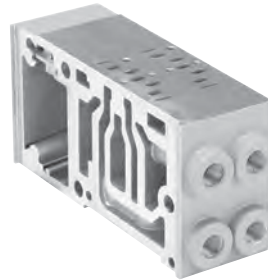

DX02 Series 2-Station Manifold



DX01 Series 2-Station Manifold



For inventory, lead time, and kit lookup, visit www.pdnplu.com

D207

Parker Hannifin Corporation
 Pneumatic Division
 Richland, Michigan
www.parker.com/pneumatics

D

Subbase & Manual Valves

H Series Micro

Moduflex Series

H Series ISO

Fieldbus Systems

DX ISOMAX Series

Valvair II Series

15407-1, DX02 & DX01 End Plate Kits

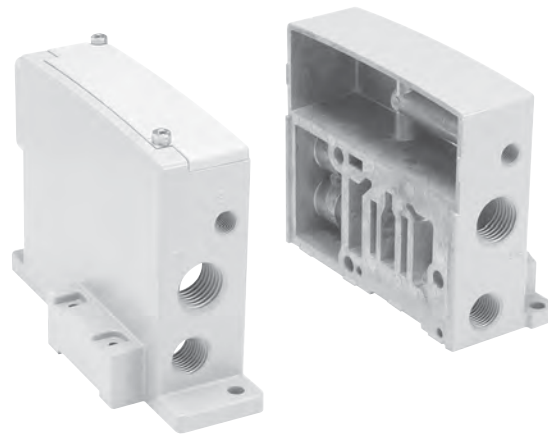
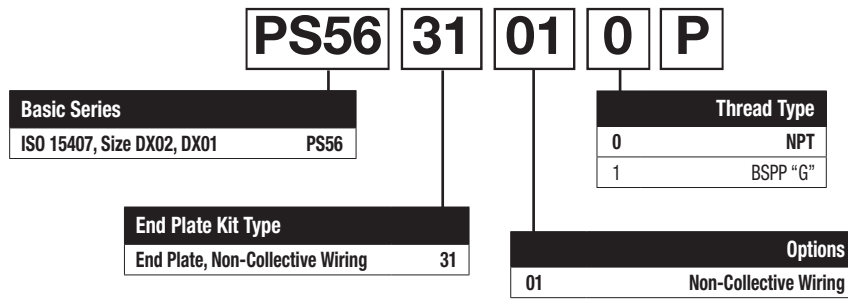

DX02 - DX01 Non-Collective Wiring End Plates

D
Subbase & Manual Valves
H Series Micro
Modulflex Series
H Series ISO
Fieldbus Systems
DX ISOMAX Series
Valvair II Series



For inventory, lead times, and kit lookup, visit www.pdnplu.com

D208

Parker Hannifin Corporation
 Pneumatic Division
 Richland, Michigan
www.parker.com/pneumatics

Sandwich Regulators Features

- Remote Air Pilot Operated for hard-to-reach pressure control.
- Unregulated Pilot Pressure to valve for consistent valve shifting regardless of pressure adjustment.

PS5637 1 6 6 DX P

Basic Series	
DX02	
15407-1, 18mm	PS5637
DX01	
15407-1, 26mm	PS5537

Regulator Function	
Common Pressure Regulator	1
Independent Pressure Regulator	2

#2 Port Regulator / Gauge*	
5	2-60 PSIG w/Gauge
6	5-125 PSIG w/Gauge

* For Common Pressure Regulator Option, Regulator Gauge callout must be the same number for both Port #4 and Port #2. (Example: 166)

#4 Port Regulator / Gauge*	
5	2-60 PSIG w/Gauge
6	5-125 PSIG w/Gauge

* For Common Pressure Regulator Option, Regulator Gauge callout must be the same number for both Port #4 and Port #2. (Example: 166)

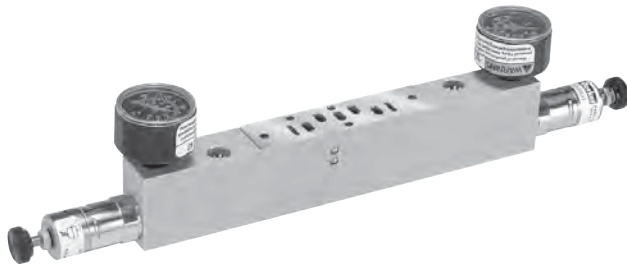

DX02
 (Independent Dual Port Regulator Shown)



DX01
 (Common Port Regulator Shown)

Remote Pilot Access Plate Kit

Size	Port size	Part number	
		NPT	BSPP
26mm DX01	1/8"	PS551500P	PS551501P



For inventory, lead time, and kit lookup, visit www.pdnplu.com

How To Order 15407-1 Non Plug-in Add-A-Fold Assemblies

1. List Add-A-Fold Assembly call out. This automatically includes the end plate kit assembly.
2. List complete Valve, Regulator, Flow Control and Base model number. List left to right, LOOKING AT THE CYLINDER PORTS on the #12 end of the manifold. The left most station is station 1. (If a blank station is needed, list the blanking plate part number and the individual manifold number in the station specified.)

Add-A-Fold Assembly Model Number

AA HBS 0 04

Valve series	
Right & left end plate 15407-1 (HB 18mm & HA 26mm)	HBS†

† For use with PS5511 and PS5611 manifolds.

Thread type	
NPT	0
BSPP "G"	1*

* BSPP conforms to ISO 1179-1 w
 228-1 threads for end plate Type "S".

Number of stations*	
02	
04	
•	
24	
•	
32	

* Must be ordered in multiples of (2)
 unless using the HB/HA to H2
 transition plate.

Example

Application requires a 4-Station manifold.
 (Two 18mm + Two 26mm Stations)

Item	Qty.	Part No.	Location
01	1	AAHBS004	
02	1	DX02-651-951M	Station 1
03	1	DX02-651-951M	Station 2
04	1	PS5611510P	Station 1 & 2
05	2	DX01-606-951M	Station 3 & 4
06	1	PS5511510P	Station 3 & 4

NOTE: Construct manifold assemblies from left to right while looking at the ports.
 Valves must be ordered as External Pilot when using Sandwich Regulator.

D

Subbase & Manual Valves

H Series Micro

Modulflex Series

H Series ISO

Fieldbus Systems

DX ISOMAX Series

Valvair II Series



For inventory, lead times, and kit lookup, visit www.pdnplu.com

DX02 Series Subbase & Manifolds

Single Subbase

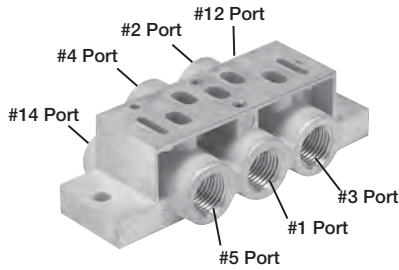

Side ported base
18mm DX02

1/8" NPT	1/8" BSPP
PL02-01-80	PL02-01-70

Note: Can be used for external, single, or double remote pilot.

2 Station Manifold Bases

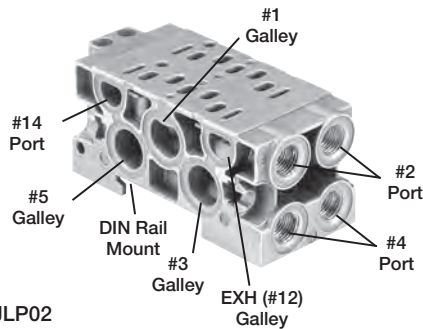

End ported bases
18mm DX02

1/8" NPT	1/8" BSPP
PJLP02-201-80	PJLP02-201-70

Note: Can be used for external pilot, not remote pilot. Gaskets and assembly hardware included.

PJLP02

End Plate Kit

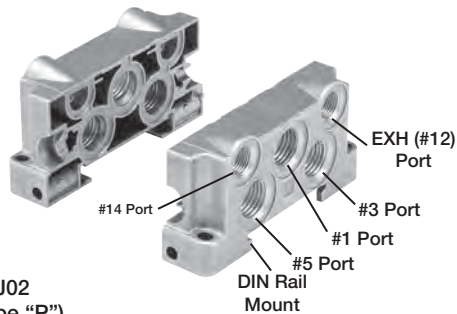

Side ported two station
manifold base
18mm DX02

1/8" NPT port	1/8" BSPP port
PEJ02-02-80*	PEJ02-02-70

*Note: Put a vent or muffler in "EXH" port when capturing pilot exhaust pressure with a solenoid valve. (See gasket selector page for details. Gaskets and assembly hardware included. Torque Specifications: 25 to 35 in-lbs (2.82 to 3.95 Nm)

PEJ02
(Type "P")

Most popular.



For inventory, lead time, and kit lookup, visit www.pdnplu.com

D211

Parker Hannifin Corporation
Pneumatic Division
Richland, Michigan
www.parker.com/pneumatics

D

Subbase & Manual
Valves

H Series
Micro

Moduflex
Series

H Series
ISO

Fieldbus
Systems

DX ISOMAX
Series

Valvair II
Series

DX01 Series Subbase & Manifolds

Single Subbase

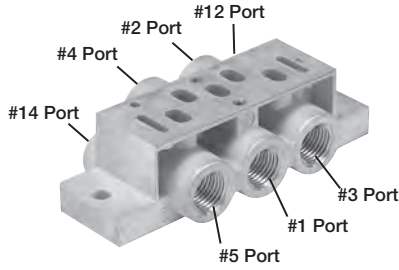

Side ported base
26mm DX01

Part number

1/4" NPT	1/4" BSPP
PL01-02-80	PL01-02-70

Note: Can be used for external, single, or double remote pilot.

2 Station Manifold Bases

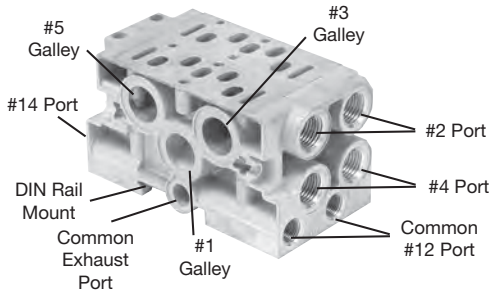

End ported bases
26mm DX01

1/4" NPT	1/4" BSPP
PJLP01-202-80	PJLP01-202-70

Note: Can be used for single remote pilot using the #14 Port and external pilot. Gaskets and assembly hardware included.

PJLP01

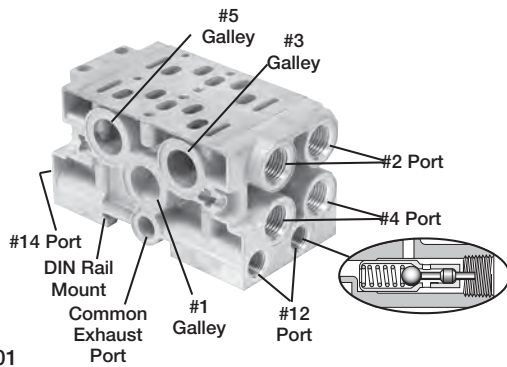

End ported bases
26mm DX01

1/4" NPT	1/4" BSPP
PJL01-202-80	PJL01-202-70

Notes: #12 ports work independently when plunger is not depressed by a plug. When a plug is inserted in #12 Port along with the captured pilot exhaust gasket selector option, pilot exhaust is sent to the Common Exhaust Port. Do Not plug exhaust, insert a vent of muffler.

Gaskets and assembly hardware included.

Can be used for external, single or double remote pilot.

PJL01

End Plate Kit

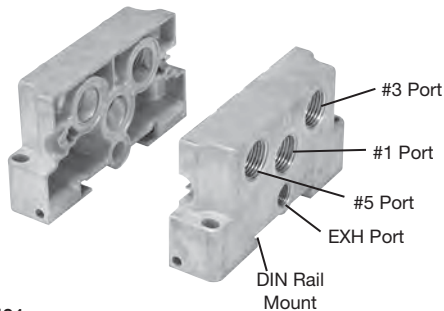

Side ported two station
manifold base
26mm DX01

1/4" NPT port	1/4" BSPP port
PEJ01-03-80*	PEJ01-03-70

* Use with PJLP01 or PJL01

Notes: Put a vent or muffler in "EXH" port when capturing pilot exhaust pressure with a solenoid valve. See page J18 for gasket selector details. Gaskets and assembly hardware included. Torque Specifications: 25 to 35 in-lbs (2.82 to 3.95 Nm)

PEJ01

Most popular.



For inventory, lead times, and kit lookup, visit www.pdnplu.com

D212

Parker Hannifin Corporation
Pneumatic Division
Richland, Michigan
www.parker.com/pneumatics

D
 Subbase & Manual
 Valves
 H Series
 Micro
 Modutefx
 Series
 H Series
 ISO
 Fieldbus
 Systems
 DX ISOMAX
 Series
 Valvair II
 Series

#14 End

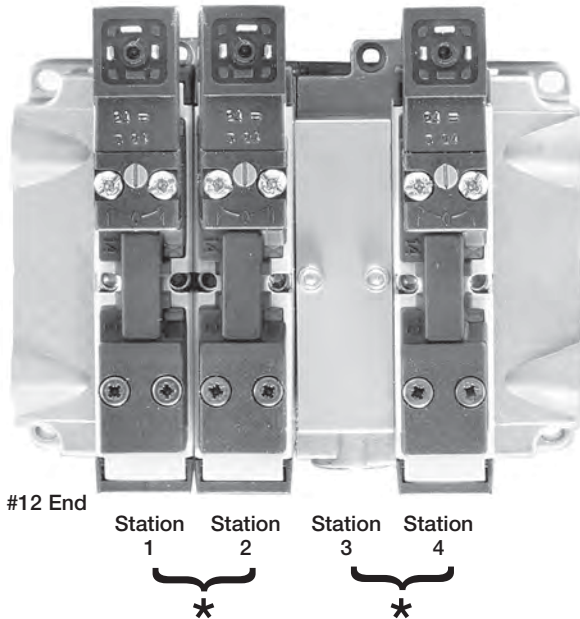

* Each Manifold has two (2) Stations
 (Even number of Stations Required)

How To Order Add-A-Fold Assemblies

1. List Add-A-Fold Assembly call out. This automatically includes the end plate kit assembly.
2. List complete valve/base model number. List left to right, looking at the cylinder ports on the #12 end of the manifold. The left most station is station 1.

(If a blank station is needed, list the blanking plate part number and the individual manifold number in the station specified.)

Model Number

AA 02U 0 04

Valve Series	
Right & Left End Plate 15407-1, DX01	01U†
Right & Left End Plate 15407-1, DX02	02U*
Right & Left End Plate 15407, DX01 & DX02	HBS*

* Common End Plates for DX01 & DX02. For use with PS5 Manifolds.

** For use with PJLP02 Manifolds.

† For use with PJLP01 or PJL01 Manifolds.

Number of Stations*	
02	2 Stations
04	4 Stations
•	
24	24 Stations
•	
32†	32 Stations

* Must be ordered in multiples of 2.

† Maximum Number.

Port Type	
0	NPT
1	BSPP "G"

Example: Application requires a 3-Valve manifold.

Qty.	Part No.
1	AA02U004
1	DX02-651-951M Valve Station 1
1	DX02-651-951M Valve Station 2
1	PJLP02-201-80.....Base Station 1 & 2
1	DX02BLK Valve Station 3
1	DX02-651-951M Valve Station 4
1	PJLP02-201-80.....Base Station 3 & 4

Note: DX02 Manifolds cannot be used for remote pilot.



For inventory, lead time, and kit lookup, visit www.pdnplu.com

D213

Parker Hannifin Corporation
 Pneumatic Division
 Richland, Michigan
www.parker.com/pneumatics

D

Subbase & Manual Valves

H Series Micro

Moduflex Series

H Series ISO

Fieldbus Systems

DX ISOMAX Series

Valvair II Series

Intermediate Air Supply Base



Size	Port size	Part number
18mm DX02	1/8" NPT	D02P-01-80
26mm DX01	1/4" NPT	D01P-02-80

Notes: Gasket & Mounting Bolts included.
Torque Specifications
Size 02: 15 to 25 in-lbs (1.69 to 2.82 Nm)
Size 01: 20 to 30 in-lbs (2.26 to 3.39 Nm)

Manifold Port Isolation Disc

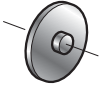

Size		Part number
18mm DX02	Common Pressure	D02BD0
26mm DX01	Common Pressure	D01BD0

Notes: 3 Discs per Kit.
Used on PJJ Manifolds.

Blanking Plate



Size		Part number
18mm DX02	Common Pressure	PS5634P
26mm DX01	Common Pressure	PS5534P

Notes: Gasket & Mounting Bolts included.
Torque Specifications
Size 02: 15 to 25 in-lbs (1.69 to 2.82 Nm)
Size 01: 20 to 30 in-lbs (2.26 to 3.39 Nm)

Sandwich Flow Control Features



DX02
18mm Shown

Size	Part number
18mm DX02	PS5642P
26mm DX01	PS5542P

- Both adjustment screws are located on the 12 end of the unit.
- Sandwich Flow Control mounts with its own studs, which means the valve uses standard bolts for mounting.
- Sandwich Flow Control is not to be used as a shut off device and is not bubble tight when needles are fully turned down.

Manifold to Manifold Gasket Kits

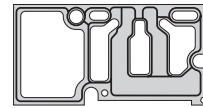

PS561AP

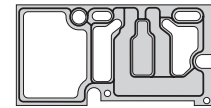

PS561BP

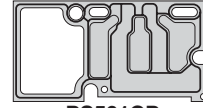

PS561CP



PS561DP



DX02M2MGSKT (PJLP02)



DX01M2MGSKT (PJLP01)

Size	Standard	Blocked #1 Port	Blocked #1, 3, 5 Ports	Blocked #3, 5 Ports
DX02* DX01*	PS561AP	PS561BP	PS561CP	PS561DP
DX02	DX02M2MGSKT (PJLP02)			
DX01	DX01M2MGSKT (PJLP01)			

* Gaskets used with PS5611 & PS5511 Manifolds.

Manifold Hardware Kits

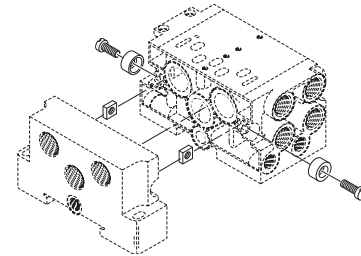

Description	Part number
Bolt, Washer & Nut*	DX02M2MB**
Tie Rods for PS5611 Manifold (Qty. 12)	PS5612P
Tie Rods for PS5511 Manifold (Qty. 12)	PS5512P

* Includes 10 Bolts, 10 Washers, 10 Nuts

** Use this number for both sizes, PJLP02 & PJLP01.



Torque Specifications: 25 to 35 in-lbs (2.82 to 3.95 Nm)

D
 Subbase & Manual Valves
 H Series Micro
 Modutrex Series
 H Series ISO
 Fieldbus Systems
 DX ISOMAX Series
 Valvair II Series



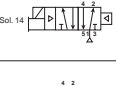

For inventory, lead times, and kit lookup, visit www.pdnplu.com

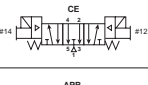
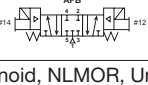
DX1 ISO Solenoid Valves



Symbol	Type	Cv	Operator	Pilot	Override	24 VDC	120 VAC
 Sol. 14	4-way, 2-position, spring return	1.15	Single solenoid	Internal	Non-locking	DX1-621-BL49	DX1-621-BL53
					Locking	DX1-621-CL49	DX1-621-CL53
 Sol. 14	4-way, 2-position, air return	1.15	Single solenoid	Internal	Non-locking	DX1-651-BL49	DX1-651-BL53
					Locking	DX1-651-CL49	DX1-651-CL53
 Sol. 14	4-way, 2-position	1.15	Double solenoid	Internal	Non-locking	DX1-606-BL49	DX1-606-BL53
					Locking	DX1-606-CL49	DX1-606-CL53
 #14	4-way, 3-position, center exhaust	0.75	Double solenoid	Internal	Non-locking	DX1-611-BL49	DX1-611-BL53
					Locking	DX1-611-CL49	DX1-611-CL53
 #14	4-way, 3-position, all ports blocked	0.75	Double solenoid	Internal	Non-locking	DX1-616-BL49	DX1-616-BL53
					Locking	DX1-616-CL49	DX1-616-CL53

30mm 3-Pin Solenoid, NLMOR, Unlighted, Internal Pilot, Valve Less Base

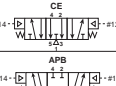
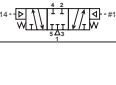
DX1 ISO Remote Pilot Valves

Symbol	Type	Cv	Operator	Pilot	Part number
 #14	4-way, 2-position, spring return	1.15	Single remote pilot	Remote	DX1-421-60
					DX1-451-60
 #14	4-way, 2-position, air return	1.15	Double remote pilot	Remote	DX1-406-60
					DX1-411-60
 #14	4-way, 3-position, center exhaust	0.75	Double remote pilot	Remote	DX1-416-60
					DX1-416-60
 #14	4-way, 3-position, all ports blocked	0.75	Double remote pilot	Remote	DX1-416-60
					DX1-416-60

DX1 Series Subbase & Manifolds

Single subbase	Description	3/8" NPT	3/8" BSPP
	Side ported base	PS4011150DP	PS4011160DP
Manifold bases	Description	3/8" NPT	3/8" BSPP
	End ported bases	PS4011550DP	PS4011560CP
	Bottom / End ported bases	PS4011650CP	PS4011660CP
End plate kits	Description	NPT port	BSPP port
	DX1 non-collective wiring end plates	PS4031010CP	PS4031011DP

5599-1, DX1 Accessories

Accessories	Description	Part number
Sandwich regulator 	Common pressure	5-125 PSIG w/ gauge PS4037166CP
	Independent pressure	5-125 PSIG w/ gauge PS4037266CP
Manifold to manifold gasket kit		PS4013P
Auxiliary access plate kit	1/4" & 3/8"	NPT PS403000CP
		BSPP PS403001CP

 Most popular.



For inventory, lead time, and kit lookup, visit www.pdnplu.com

D215

Parker Hannifin Corporation
Pneumatic Division
Richland, Michigan
www.parker.com/pneumatics

D

Subbase & Manual Valves

H Series Micro

Modulflex Series



H Series ISO

Fieldbus Systems

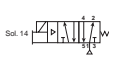

DX ISOMAX Series

Valvair II Series

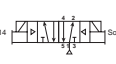
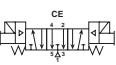
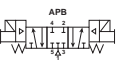

DX2 ISO Valves

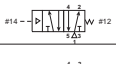
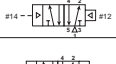
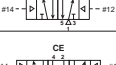
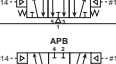
Symbol	Type	Cv	Operator	Pilot	Override	24 VDC	120 VAC
	4-way, 2-position, spring return	2.5	Single solenoid	Internal	Non-locking	DX2-621-BL49	DX2-621-BL53
					Locking	DX2-621-CL49	DX2-621-CL53
	4-way, 2-position, air return	2.5	Single solenoid	Internal	Non-locking	DX2-651-BL49	DX2-651-BL53
					Locking	DX2-651-CL49	DX2-651-CL53
	4-way, 2-position	2.5	Double solenoid	Internal	Non-locking	DX2-606-BL49	DX2-606-BL53
					Locking	DX2-606-CL49	DX2-606-CL53
	4-way, 3-position, center exhaust	2.4	Double solenoid	Internal	Non-locking	DX2-611-BL49	DX2-611-BL53
					Locking	DX2-611-CL49	DX2-611-CL53
	4-way, 3-position, all ports blocked	2.4	Double solenoid	Internal	Non-locking	DX2-616-BL49	DX2-616-BL53
					Locking	DX2-616-CL49	DX2-616-CL53

DX2 ISO Remote Pilot Valves

Symbol	Type	Cv	Operator	Pilot	Part number
	4-way, 2-position, spring return	2.5	Single remote pilot	Remote	DX2-421-60
	4-way, 2-position, air return	2.5	Single remote pilot	Remote	DX2-451-60
	4-way, 2-position	2.5	Double remote pilot	Remote	DX2-406-60
	4-way, 3-position, center exhaust	2.4	Double remote pilot	Remote	DX2-411-60
	4-way, 3-position, all ports blocked	2.4	Double remote pilot	Remote	DX2-416-60

DX2 Series Subbase & Manifolds

Single subbase	Description	1/2" NPT	1/2" BSPP
	Side ported base	PS4111170CP	PS4111180CP
Manifold bases		1/2" NPT	1/2" BSPP
	Bottom / End ported bases Note: Manifolds include 2 pipe plugs	PS4111670CP	PS4111680CP
End plate kits		NPT port	BSPP port
	H2 Non-collective wiring end plates	PS4131010DP	PS4131011DP

5599-1, DX2 Accessories

Accessories	Description	Part number
	Common pressure 5-125 PSIG w/ gauge	PS4137166CP
	Independent pressure 5-125 PSIG w/ gauge	PS4137266CP
Manifold to manifold gasket kit		PS4113P

 Most popular.





For inventory, lead times, and kit lookup, visit www.pdnplu.com

D216



Parker Hannifin Corporation
 Pneumatic Division
 Richland, Michigan
www.parker.com/pneumatics

D
 Subbase & Manual Valves
 H Series Micro
 Modutrex Series
 H Series ISO
 Fieldbus Systems
 DX ISOMAX Series
 Valvair II Series

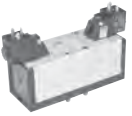
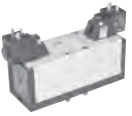
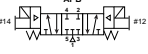

DX3 ISO Valves

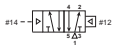
Symbol	Type	Cv	Operator	Pilot	Override	24 VDC	120 VAC
 Sol. 14	4-way, 2-position, spring return	4.15	Single solenoid	Internal	Non-locking	DX3-621-BL49	DX3-621-BL53
					Locking	DX3-621-CL49	DX3-621-CL53
 Sol. 14	4-way, 2-position, air return	4.15	Single solenoid	Internal	Non-locking	DX3-651-BL49	DX3-651-BL53
					Locking	DX3-651-CL49	DX3-651-CL53
 Sol. 14 Sol. 12	4-way, 2-position	4.15	Double solenoid	Internal	Non-locking	DX3-606-BL49	DX3-606-BL53
					Locking	DX3-606-CL49	DX3-606-CL53
 CE	4-way, 3-position, center exhaust	4.0	Double solenoid	Internal	Non-locking	DX3-611-BL49	DX3-611-BL53
					Locking	DX3-611-CL49	DX3-611-CL53
 APB	4-way, 3-position, all ports blocked	4.0	Double solenoid	Internal	Non-locking	DX3-616-BL49	DX3-616-BL53
					Locking	DX3-616-CL49	DX3-616-CL53

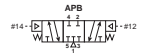
DX3 ISO Remote Pilot Valves

Symbol	Type	Cv	Operator	Pilot	Part number
 #14 - #12	4-way, 2-position, spring return	4.15	Single remote pilot	Remote	DX3-421-60
					DX3-451-60
 #14 - #12	4-way, 2-position, air return	4.15	Single remote pilot	Remote	DX3-406-60
					DX3-411-60
 #14 - #12	4-way, 3-position, center exhaust	4.0	Double remote pilot	Remote	DX3-416-60
					DX3-421-60
 #14 - #12	4-way, 3-position, all ports blocked	4.0	Double remote pilot	Remote	DX3-416-60
					DX3-421-60

DX3 Series Subbase & Manifolds

Single subbase	Description	3/4" NPT	3/4" BSPP
	Side ported base	PS4211190CP	PS4211100CP
Manifold bases		3/4" NPT	3/4" BSPP
	Bottom / End ported bases Note: Manifolds include 2 pipe plugs	PS4211690CP	PS4211600CP
End plate kits		NPT port	BSPP port
	H3 Non-collective wiring end plates	PS4231010DP	PS4231011DP

5599-1, DX3 Accessories

Accessories	Description	Part number
Sandwich regulator 	Common pressure 5-125 PSIG w/ gauge	PS4237166CP
	Independent pressure 5-125 PSIG w/ gauge	PS4237266CP
Manifold to manifold gasket kit		PS4213P

 Most popular.



For inventory, lead time, and kit lookup, visit www.pdnplu.com

D217

Parker Hannifin Corporation
 Pneumatic Division
 Richland, Michigan
www.parker.com/pneumatics

D

Subbase & Manual Valves

H Series Micro

Modulflex Series

H Series ISO

Fieldbus Systems

DX ISOMAX Series

Valvair II Series

D
 Subbase & Manual Valves
 H Series Micro
 Modulflex Series
 H Series ISO
 Fieldbus Systems
 DX ISOMAX Series
 Valvair II Series

DX1

Basic Series	
ISO 5599-1	DX1 - Size 1
ISO 5599-1	DX2 - Size 2
ISO 5599-1	DX3 - Size 3

6 21

Pilot	
Air Operated Remote Pilot	4
Solenoid Operated	6

Function	
Internal Pilot Supply	
2-Position, Spring Return, Air Assist	21
2-Position, Diff Return	51
2-Position	06
3-Position, CE	11
3-Position, APB	16
3-Position, PC	13*
External Pilot Supply†	
2-Position, Spring Return, Air Assist	22
2-Position, Diff Return	53
2-Position	08
3-Position, CE	12
3-Position, APB	18
3-Position, PC	24*

* Not offered with DX3 Valves.
 † Must be specified when using Sandwich Regulators.

B L 53

Voltage & Frequency			
	AC		DC
	60Hz	50Hz	
19*			24
49			24
53	120	110	
Blank	Remote Pilot or Valve Less Coil		

* LED & Surge Suppression.
 Only Available with Enclosure "6".

5599-1 Enclosure / Lead Length / Light	
0**	None, Remote Pilot Valve
6*	2-Pin, M12 EURO Connector with CNOMO Operator, Light
L	3-Pin, 30mm DIN 43650A with CNOMO Connector, No Light
P	3-Pin, 22mm Industrial with CNOMO Connector, No Light
N†	None, Valve Less Coil, No Light

* Only available with Voltage & Frequency "19".
 **Must use Overrides Option "6".
 † Must use Overrides Option "B" or "C".

5599-1 Overrides	
6	Remote Pilot / Without Solenoid
B	Non-Locking, Flush, Push
C	Locking, Flush, Push / Turn



For inventory, lead times, and kit lookup, visit www.pdnplu.com

5599-1, DX1, DX2 & DX3 Hi-Flow Manifold / Subbase Kits

PS401155 **0** **C** **P**

Enclosures / Lead Length
0 None, No Electrical Plug - 5599-1

Mounting Base Style / Port Size		DX2 Series		DX3 Series	
DX1 Series		DX2 Series		DX3 Series	
Subbase: 3/8 NPT Side Ports	PS401115	Subbase: 1/2 NPT Side Ports	PS411117	Subbase: 3/4 NPT Side Ports	PS421119
Subbase: 3/8 BSPP Side Ports	PS401116	Subbase: 1/2 BSPP Side Ports	PS411118*	Subbase: 3/4 BSPP Side Port	PS421110*
Manifold: 3/8 NPT End Ports	PS401155	Subbase: 1/2 NPT Bottom / End Port	PS411127	Subbase: 3/4 NPT Bottom / End Port	PS421129
Manifold: 3/8 BSPP End Ports	PS401156*	Subbase: 1/2 BSPP Bottom / End Port	PS411128*	Subbase: 3/4 BSPP Bottom / End Port	PS421120*
Manifold: 3/8 NPT Bottom / End Port	PS401165†	Manifold: 1/2 NPT End Port	PS411157	Manifold: 3/4 NPT End Port	PS421159
Manifold: 3/8 BSPP Bottom / End Port	PS401166*†	Manifold: 1/2 BSPP End Ports	PS411158*	Manifold: 3/4 BSPP End Port	PS421150*
* BSPP Conforms to ISO 1179-1 w 228-1 Threads.		Manifold: 1/2 NPT Bottom / End Port	PS411167	Manifold: 3/4 NPT Bottom / End Port	PS421169
† #1 Bottom Port - 1/4".		Manifold: 1/2 BSPP Bottom / End Port	PS411168*	Manifold: 3/4 BSPP Bottom / End Port	PS421160*

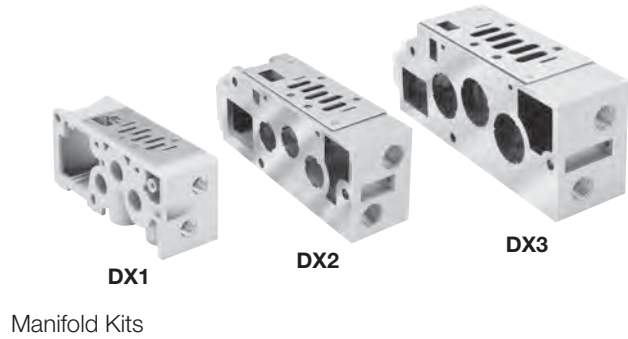
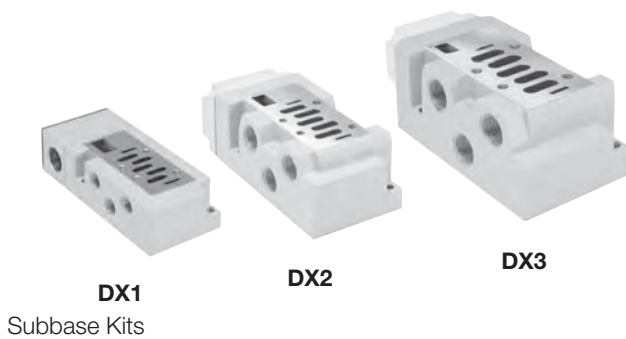

D

Subbase & Manual Valves

H Series Micro

Moduflex Series

H Series ISO

Fieldbus Systems

DX ISOMAX Series

Valvair II Series



For inventory, lead time, and kit lookup, visit www.pdnplu.com

Non-Plug-in, 5599-1, End Plate Kits

PS403101 0 C P

Basic Series	
ISO 5599, Size 1	PS403101
ISO 5599, Size 2	PS413101
ISO 5599, Size 3	PS423101

Thread Type	
0	NPT
1*	BSP "G"

* BSP Conforms to ISO 1179-1 w 228-1 Threads.



H1 Non-Collective Wiring End Plates

5599-1, DX1, DX2 & DX3 Transition Plate Kits for PS4 Manifolds

PS402701 0 C P

Transition Plate Type	
DX1 to DX2 to DX3	PS402501
DX1 to DX3	PS402601
DX1 to DX2	PS402701
DX2 to DX3	PS402801

Engineering Level	
C	Current

Thread Type	
0	NPT
1	BSP "G"

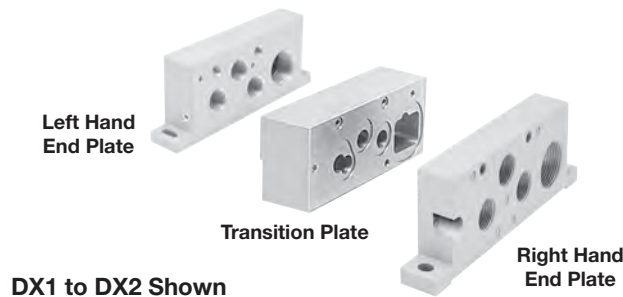

Left Hand End Plate

Transition Plate

Right Hand End Plate

DX1 to DX2 Shown

D

Subbase & Manual Valves

H Series Micro

Modulflex Series

H Series ISO

Fieldbus Systems

DX ISOMAX Series

Valvair II Series



For inventory, lead times, and kit lookup, visit www.pdnplu.com

D220

Parker Hannifin Corporation
 Pneumatic Division
 Richland, Michigan
www.parker.com/pneumatics

Sandwich Regulators Features

- Remote Air Pilot Operated for hard-to-reach pressure control.
- Unregulated Pilot Pressure to valve for consistent valve shifting regardless of pressure adjustment.

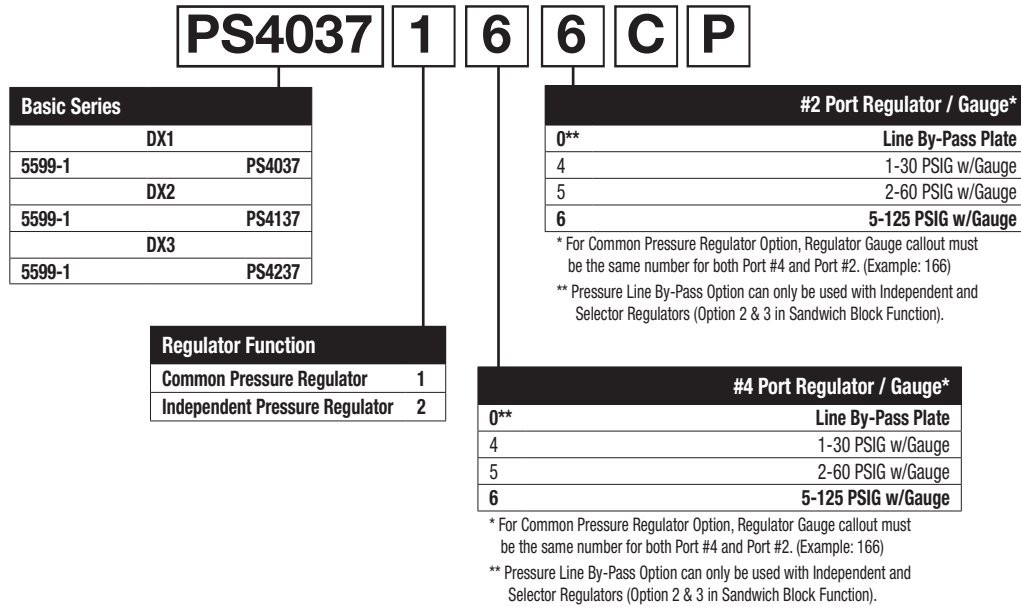

DX1 - Size 1
 (Independent Dual Port Regulator Shown)

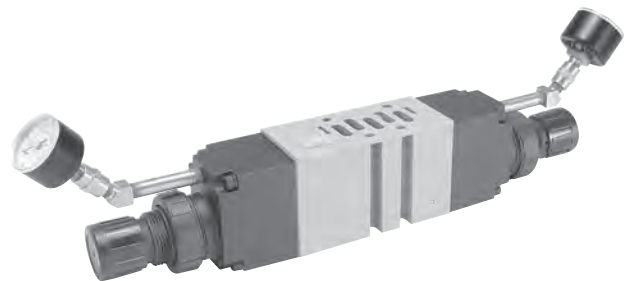

DX2 - Size 2
 (Independent Dual Port Regulator Shown)

Ordering Components

- Manifold or Subbase Kit required.
- Sandwich Regulator Kit configured for Internal Pilot as standard.
- Order valve as External Pilot.

How to Configure Sandwich Regulator / Valve Combinations

Internal Pilot Configuration -

Pressure in Base Port 1 feeds regulator configured for Internal Pilot which feeds valve configured for External Pilot.

External Pilot Configuration - DX1, DX2, DX3

An External Pilot pressure in Port 12 or 14 of the base feeds thru the Sandwich Regulator 12 or 14 galley directly to the 12/14 pilot of the valve. This configuration takes an External Pilot from the 12 port of the base and passes it thru the regulator to feed the 12 galley of the valve.



For inventory, lead time, and kit lookup, visit www.pdnplu.com

D221

Parker Hannifin Corporation
 Pneumatic Division
 Richland, Michigan
www.parker.com/pneumatics

D

Subbase & Manual Valves

H Series Micro

Moduflex Series

H Series ISO

Fieldbus Systems

DX ISOMAX Series

Valvair II Series

How To Order Add-A-Fold Assemblies

1. List Add-A-Fold Assembly call out. This automatically includes the end plate kit assembly.
2. List complete valve/base model number. List left to right, looking at the cylinder ports on the #12 end of the manifold. The left most station is station 1.
 (If a blank station is needed, list the blanking plate part number and the individual manifold number in the station specified.)

Example: Application requires a 3-Station manifold.

Qty.	Part No.
1	AAH1S003
1	DX1-621-BL49..... Valve Station 1
1	PS4011550CPBase Station 1
1	DX1-616-BL49 Valve Station 2
1	PS4011550CPBase Station 2
1	DX1-611-BL49 Valve Station 3
1	PS4011550CPBase Station 3

#14 End



#12 End

Station 1 Station 2

AA H1 S 0 03 -

Valve series	
DX1, ISO Size 1	H1

Transition plate	
Blank	No transition plate
C	DX1 to DX2
D	DX1 to DX3

End plate type	
Standard non-collective wiring	S

Number of stations*	
01	
•	
•	
•	
24	

Port type	
NPT	0
BSPP "G"	1

D

Subbase & Manual Valves

H Series Micro

Modulflex Series

H Series ISO

Fieldbus Systems

DX ISOMAX Series

Valvair II Series

Most popular.



For inventory, lead times, and kit lookup, visit www.pdnplu.com

D222

Parker Hannifin Corporation
 Pneumatic Division
 Richland, Michigan
www.parker.com/pneumatics

How To Order Add-A-Fold Assemblies

1. List Add-A-Fold Assembly call out. This automatically includes the end plate kit assembly.
2. List complete valve/base model number. List left to right, looking at the cylinder ports on the #12 end of the manifold. The left most station is station 1.
 (If a blank station is needed, list the blanking plate part number and the individual manifold number in the station specified.)

Example: Application requires a 3-station manifold.

Qty.	Part No.
1	AAH2S003
1	DX2-621-BL49..... Valve Station 1
1	PS4111570CP.....Base Station 1
1	DX2-616-BL49 Valve Station 2
1	PS4111570CP.....Base Station 2
1	DX2-611-BL49 Valve Station 3
1	PS4111570CP.....Base Station 3

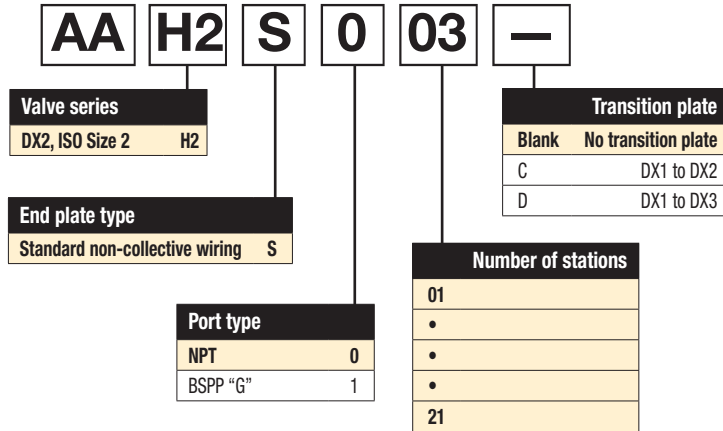

Most popular.



For inventory, lead time, and kit lookup, visit www.pdnplu.com

D223

Parker Hannifin Corporation
 Pneumatic Division
 Richland, Michigan
www.parker.com/pneumatics

D
Subbase & Manual Valves
H Series Micro
Moduflex Series
H Series ISO
Fieldbus Systems
DX ISOMAX Series
Valvair II Series

How To Order Add-A-Fold Assemblies

1. List Add-A-Fold Assembly call out. This automatically includes the end plate kit assembly.
2. List complete valve/base model number. List left to right, looking at the cylinder ports on the #12 end of the manifold. The left most station is station 1.
 (If a blank station is needed, list the blanking plate part number and the individual manifold number in the station specified.)

Example: Application requires a 3-station manifold.

Qty.	Part No.
1	AAH3S003
1	DX3-621-BL49..... Valve Station 1
1	PS4111590CPBase Station 1
1	DX3-616-BL49 Valve Station 2
1	PS4111590CPBase Station 2
1	DX3-611-BL49 Valve Station 3
1	PS4111590CPBase Station 3

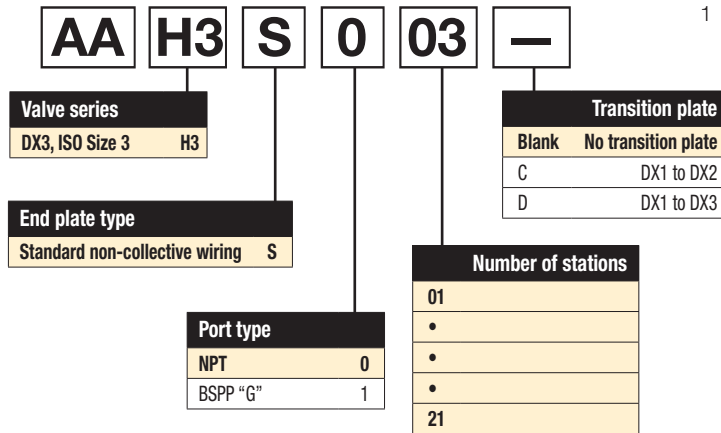

D	Subbase & Manual Valves
	H Series Micro
	Modulflex Series
	H Series ISO
	Fieldbus Systems
	DX ISOMAX Series
	Valvair II Series

Most popular.





For inventory, lead times, and kit lookup, visit www.pdnplu.com

5599-1 Compact Manifolds, Subbases & Accessories

Manifold VDMA – Form C			Part number	
	Bottom Port	Size	Port size	
		DX1	1/4"	BSPP G
		DX2	3/8"	P2N-VM512MB
		DX3	1/2"	P2N-WM513MB

VDMA End Plates – Form D			Part number	
		Size	Port size	
		DX1	3/8"	BSPP G
		DX2	1/2"	P2N-VM513ES
		DX3	1"	P2N-WM514ES

Subbase – Side Ports (5599-1 & VDMA)	Size	Port Size	5599-1 Part number		VDMA Part number
			NPT	BSPP “G”	BSPP “G”
	DX1	1/4"	PL1-1/4-80	PL1-1/4-70	P2N-VS512SD
	DX2	3/8"	PL2-3/8-80	PL2-3/8-70	P2N-WS513SD
	DX3	1/2"	PL3-1/2-80	PL3-1/2-70	P2N-YS514SD

Subbase – Bottom Ports	Size	Port size	5599-1 Part number	
			NPT	BSPP “G”
	DX1	1/4"	PD1-1/4-80	PD1-1/4-70
	DX2	3/8"	PD2-3/8-80	PD2-3/8-70

VDMA Transition Plate	Part number
 <small>DX1 (Not Included)</small> <small>Transition Plate</small> <small>DX3 (Not Included)</small>	P2N-VM500AK
	Kit includes: <u>Transition Plate Only</u> . Order P2N-VM513ES and P2N-YM518ES Separately to Assemble Add-A-Fold

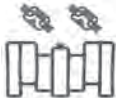
External Seal Kit	Size	Part number
	DX1	JJDX10-A
	DX2	JJDX20-A
	DX3	JJDX30-A

Complete Seal Kit	Size	Part number
	DX1	JJDX15-A
	DX2	JJDX25-A
	DX3	JJDX35-A

D

Subbase & Manual Valves

H Series Micro

Modulflex Series

H Series ISO

Fieldbus Systems

DX ISOMAX Series

Valvair II Series



For inventory, lead time, and kit lookup, visit www.pdnplu.com

Blanking Plate Kits

Size	Part number
DX1	PS4034CP
DX2	PS4134CP
DX3	PS4234CP

Kit includes:
Blanking Plate, Gasket, and Mounting Bolts.

Remote Pilot Access Plate Kits

Size	Port Size	Part number	
		NPT	BSPP "G"
DX1	1/8"	PS401500CP	PS401501CP
DX2	1/8"	PS411500CP	PS411501CP
DX3	1/8"	PS421500CP	PS421501CP

Kit includes: Pilot Port Access Plate, Gasket and Mounting Studs.

Manifold Port Isolation Kits

Main Galley (1, 3, 5)	Part number	
	PS4 Manifolds	P2N Manifolds
DX1	PS4032CP	P2N-VK0P
DX2	PS4132CP	P2N-WK0P
DX3	PS4232CP	P2N-YK0P

Kit includes: Plugs with O-rings.

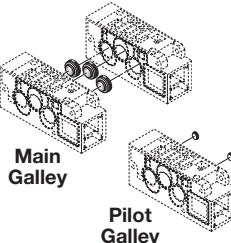

Pilot Galley

Size	Part number
DX1, DX2, DX3	PS4033CP

Kit includes: Plugs with O-rings.
For use with PS4 Series Manifolds.

Sandwich Flow Controls Features

Size	Part number
DX1	PS4042CP
DX2	PS4142CP
DX3	PS4242CP

DX2 Shown

- Both adjustment screws are located on the 12 end of the unit.
- Sandwich Flow Control mounts with its own studs, which means the valve uses standard bolts for mounting.
- Sandwich Flow Control is not to be used as a shut off device and is not bubble tight when needles are fully turned down.

22mm Rectangular 3-Pin – Type B Industrial

(Use with Enclosure "B")

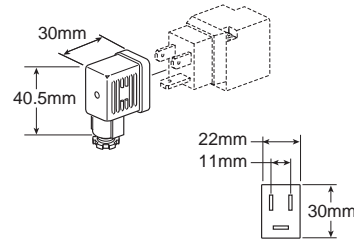

Description	Connector	Connector with 6' (2m) Cord
Unlighted	PS2429BP	PS2429JBP
Light – 24V/60Hz, 24VDC	PS243079BP	PS2430J79BP*
Light – 120V/60Hz	PS243083BP	PS2430J83BP*
Light – 240V/60Hz	PS243087BP	N/A

* LED with surge suppression.

Note: Max ϕ 6.5mm cable size required for connector w/o 6' (2m) cord. IP65 rated when properly installed.

Engineering Data:

Conductors: 2 Poles Plus Ground; Cable Range (Connector Only): 6 to 8mm (0.24 to 0.31 Inch); Contact Spacing: 11mm

CNOMO Operator Adapter

Size	Part number
DX1, DX2, DX3	PS2855P



D
 Subbase & Manual Valves
 H Series Micro
 Moduteflex Series
 H Series ISO
 Fieldbus Systems
 DX ISOMAX Series
 Valvair II Series



For inventory, lead times, and kit lookup, visit www.pdnplu.com

15mm 3-Pin DIN 43650C Replacement Solenoid Kits

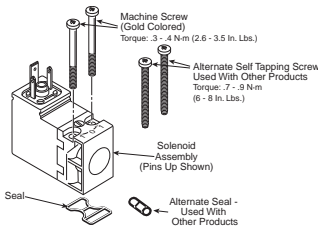

Voltage	Non-locking	Locking
24VDC	PS2982B49P	PS2982C49P
110/50, 120/60	PS2982B53P	PS2982C53P

15mm 3-Pin DIN 43650C Connectors

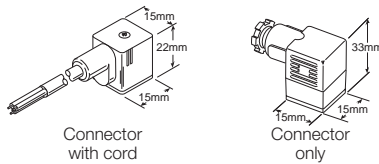

Description	Connector with 6' (2m) Cord	Connector
No circuit board	PS2932JBP	PS2932BP
Light - 24DC	PS2946J79BP*	PS294679BP
Light - 110/120VAC	PS2946J83BP*	PS294683BP

* LED with surge suppression.

Note: Max. ø6.5mm cable size required for connector without 6' (2m) cord. IP65 rated when properly installed.

Engineering Data:

Conductors: 2 poles plus ground
Cable range (Connector only): 4 to 6mm (0.16 to 0.24 Inch)
Contact spacing: 8mm

Female Electrical Connectors (IP65 Rated) 30mm, 3-Pin ISO 4400, (DIN 43650A)

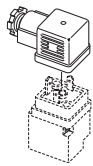

Description	Connector with 6' (2m) cord	Connector
Unlighted	PS2028JCP	PS2028BP
Light - 6-48V, 50/60Hz; 6-48VDC	PS2032J79CP*	PS203279BP
Light - 120V/60Hz	PS2032J83CP*	PS203283BP
Light - 240V/60Hz	N/A	PS203283BP

* With surge suppression.

Engineering data:

Conductors: 2 poles plus ground; cable range (connector only): 8 to 10mm (0.31 To 0.39 inch); Contact spacing: 18mm

5599-1 CNOMO Solenoid Kits

Voltage code	3-pin, 30mm 'L' coil kit	2-pin, M12 Euro '6' coil kit
19	—	PS2828619P
42	P2FCA442	—
45	P2FCA445	—
49	P2FCA449	—
53	P2FCA453	—
57	P2FCA457	—

Quantity 1

Pilot Operator - CNOMO

Valve size	Kit number
DX1, DX2 & DX3	Locking PS4052CP
	Non-locking PS4053CP



For inventory, lead time, and kit lookup, visit www.pdnplu.com

D227

Parker Hannifin Corporation
Pneumatic Division
Richland, Michigan
www.parker.com/pneumatics

D

Subbase & Manual Valves

H Series Micro

Moduflex Series

H Series ISO

Fieldbus Systems

DX ISOMAX Series

Valvair II Series

Ceramic Technology / Valve Specifications

- Subbase Mounted Valves Conforming to ISO Standard 5599/1
- High Flow: DX1 (1.15 Cv), DX2 (2.50 Cv), DX3 (4.15 Cv)
- Air or Solenoid Operation Using CNOMO Solenoids
- Can Be Vacuum Operated

Air Condition:
 Filtered to 40µ

Dual Pressure Supply from Exhaust Ports:
 Yes - Without additional pressure at 12 and 14

Dust and Water Protection:
 IP65 (According to EN 60529)

Mechanical Life:
 > 100 million operations (Dry air filtered 40 µ, 2 Hz, 6 bar, 20°C)

Media:
 Air or inert gas, filtered 40 µ (Class 5 according to ISO 8573-1), lubricated or non-lubricated

Operating Temperature Range:
 -10°C to 60°C (14°F to 140°F)

Flow Rating (Cv)

Size	Port Size	Mounting Style	Flow Rating (Cv)	
			2-Position	3-Position
DX1	1/4" Ports	Subbase	1.15	0.75
	1/4" Ports	Manifold	0.80	0.60
DX2	3/8" Ports	Subbase	2.50	2.40
	3/8" Ports	Manifold	2.05	1.95
DX3	1/2" Ports	Subbase	4.15	4.00
	1/2" Ports	Manifold	4.10	3.65

Cv tested per ANSI / (NFPA) T3.21.3

Flow Rating (Cv) with Sandwich Regulator

Size	Common Pressure				Dual Pressure			
	1-2	1-4	2-3	4-5	1-2	1-4	2-3	4-5
DX1	0.55	0.49	1.06	1.02	0.32	0.42	0.25	0.38
DX2	1.06	1.05	2.33	2.17	0.93	0.66	0.77	1.15

Note: All Cv's calculated with regulator adjusted full open.

Response Time**

Single Solenoid 2-Position -
 Air Return / Spring Assist

Size	Port Size	0 Cu. In. Chamber		## Cu. In. Chamber	
		Fill	Exhaust	Fill	Exhaust
DX1	1/4"	.025	.030	.160	.235
DX2	3/8"	.040	.045	.170	.235
DX3	1/2"	.060	.065	.245	.330

DX1 (50), DX2 (100), DX3 (200)

** With 100 PSIG supply, time required to fill from 0 to 90 PSIG and Exhaust from 100 PSIG to 10 PSIG measured from the instant of energizing or de-energizing 24VDC solenoid.

Tested per ANSI / (NFPA) T3.21.8

Solenoid Information

Code	Voltage			Power (W / VA)
	AC			
	60Hz	50Hz	DC	
19	—	—	24	2.8W
49	—	—	24	2.7W
53	120	115	—	3.7VA

Data tested with LED and Surge Suppression.

Operating Pressure

Vacuum to 145 PSIG (10 bar)

Function	M.O.P. (PSIG)		
	DX1	DX2	DX3
Internal Pilot			
21 2-Position, Spring Return	36	30	30
51 2-Position, Air Return	30	30	30
06 2-Position	15	15	15
11 3-Position, CE	45	36	36
16 3-Position, APB	45	36	36
13 3-Position, PC	45	36	—
External Pilot			
22 2-Position, Spring Return	36	30	30
53 2-Position, Air Return	30	30	30
08 2-Position	15	15	15
12 3-Position, CE	45	36	36
18 3-Position, APB	45	36	36
24 3-Position, PC	45	36	—

D

Subbase & Manual Valves

H Series Micro

Modutrex Series

H Series ISO

Fieldbus Systems

DX ISOMAX Series

Valvair II Series



For inventory, lead times, and kit lookup, visit www.pdnplu.com

DX ISOMAX Selector Gasket Conversion Instructions

Changing from Internal to External Pilot Supply

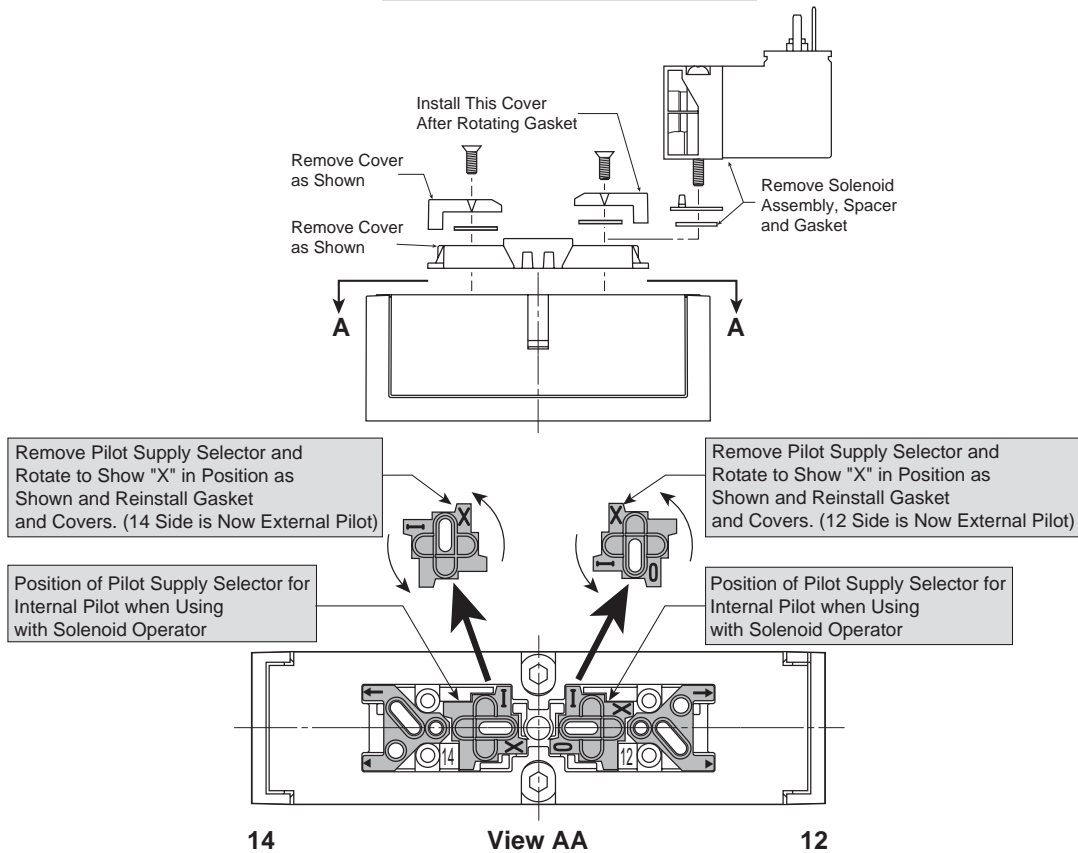

Changing from External Pilot Supply, Vented Pilot Exhaust to Internal Pilot Supply, Captured Pilot Exhaust

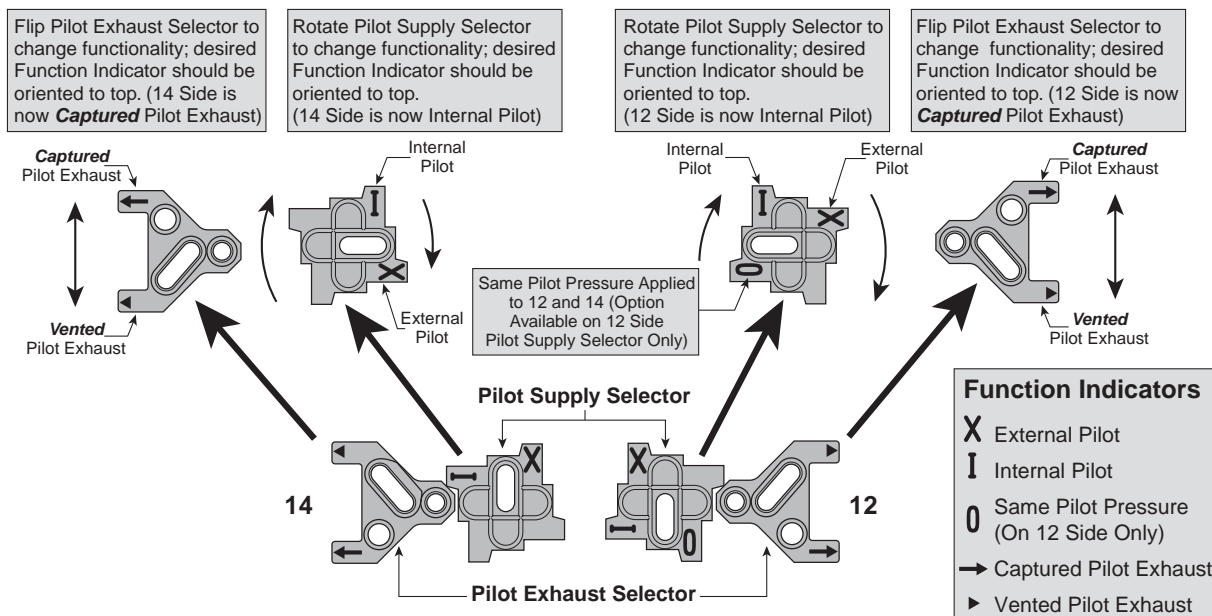

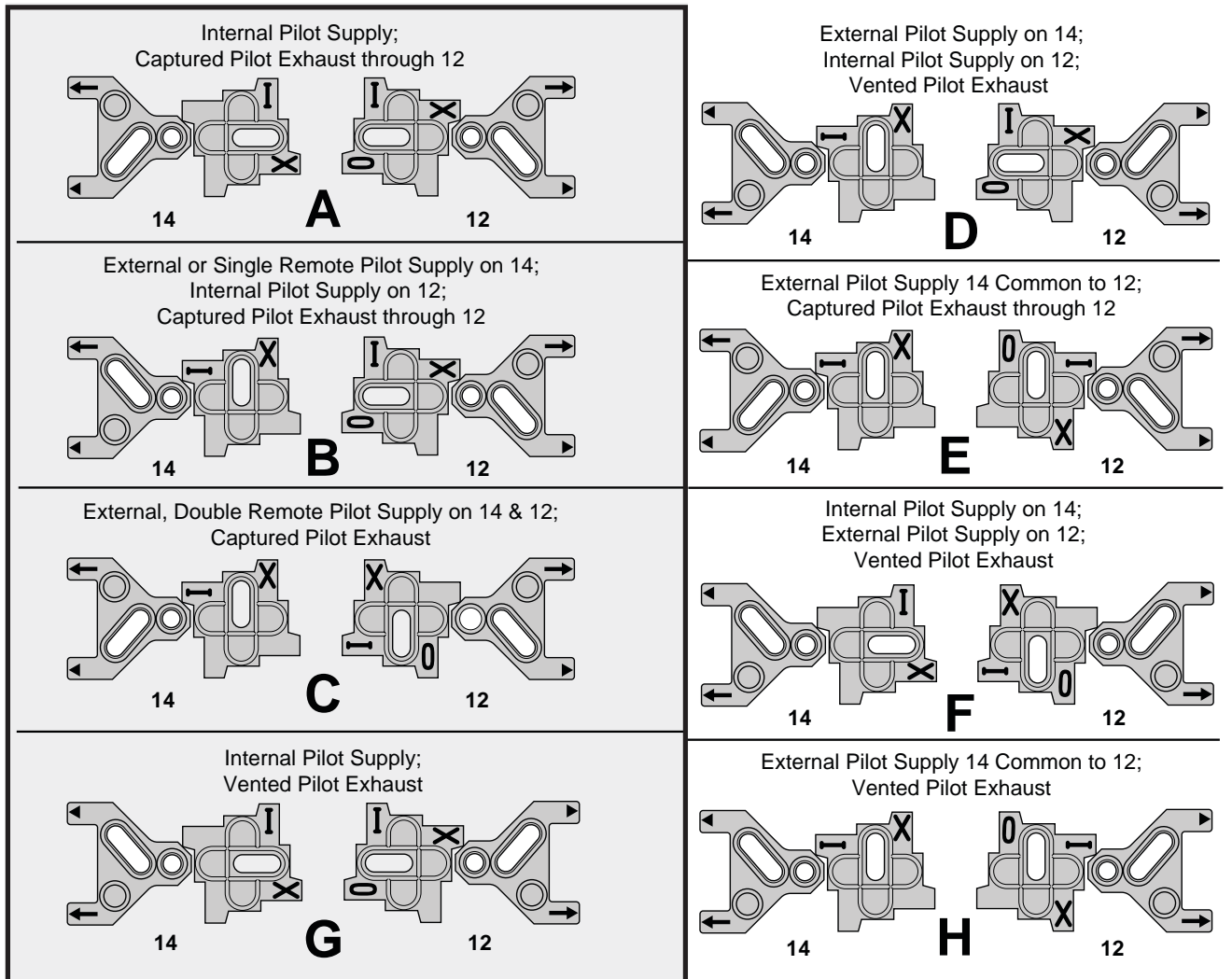

Base Pilot Port Used	None	14	14 and 12	None	14	14	12
Pilot Air Supply	Internal Pilot Supply	14 External Pilot 12 Internal Pilot	External, Double Remote Pilot for 14 and 12	Internal Pilot Supply	14 External Pilot 12 Internal Pilot	One Common External Pilot Pressure for 14 and 12	14 Internal Pilot 12 External Pilot
Pilot Exhaust	Captured	Captured	Captured	Vented	Vented	Captured	Vented
5/2 Double Solenoid	606 A	—	406 C	604 G	D	E	F
5/2 Single Solenoid	621	421	C	620	D	E	F
5/2 Double Solenoid, on Sandwich Regulator	—	—	—	—	External Pilot Supply 14 Common to 12 Vented Pilot Exhaust – See Diagram 'H'		
Spring Return	A	B	—	G	—	—	—
5/2 Single Solenoid, Differential Return	651 A	451 B	C	65 G	D	E	F
5/3 Pressure Center Exhaust	611 A	—	411 C	627 G	D	E	F
5/3 Pressure All Ports Blocked	616 A	—	416 C	625 G	D	E	F
Part Numbers Available From Factory					See Gasket Configurations Above for These Special Adaptations		

Insert a muffler or vent in the EXH Port of the PEJ02 & PEJ01 Manifold End Plates or #12 of PL02 & PL01 Subbases when using solenoids with a **Captured** Exhaust.

A plug may be inserted in the EXH Port of the PEJ02 & PEJ01 Manifold End Plates #14 or #12 of PL02 & PL01 Subbases when using a **Vented** Exhaust.

D
 Subbase & Manual Valves
 H Series Micro
 Modutefx Series
 H Series ISO
 Fieldbus Systems
 DX ISOMAX Series
 Valvair II Series



For inventory, lead times, and kit lookup, visit www.pdnplu.com

D230

Parker Hannifin Corporation
 Pneumatic Division
 Richland, Michigan
www.parker.com/pneumatics

DX01 Manifold Assembly

Ports

- 1 Pressure
- 2 #2 Cylinder Port, 1 to 2 Flow Path
- 3 Cylinder Exhaust Port, 2 to 3 Flow Path
- 4 #4 Cylinder Port, 1 to 4 Flow Path
- 5 Cylinder Exhaust Port, 4 to 5 Flow Path
- 14 #14 Pilot Port
- 12 #12 Pilot Port

Torque Specifications: 25 to 35 in-lbs (2.82 to 3.95 Nm)

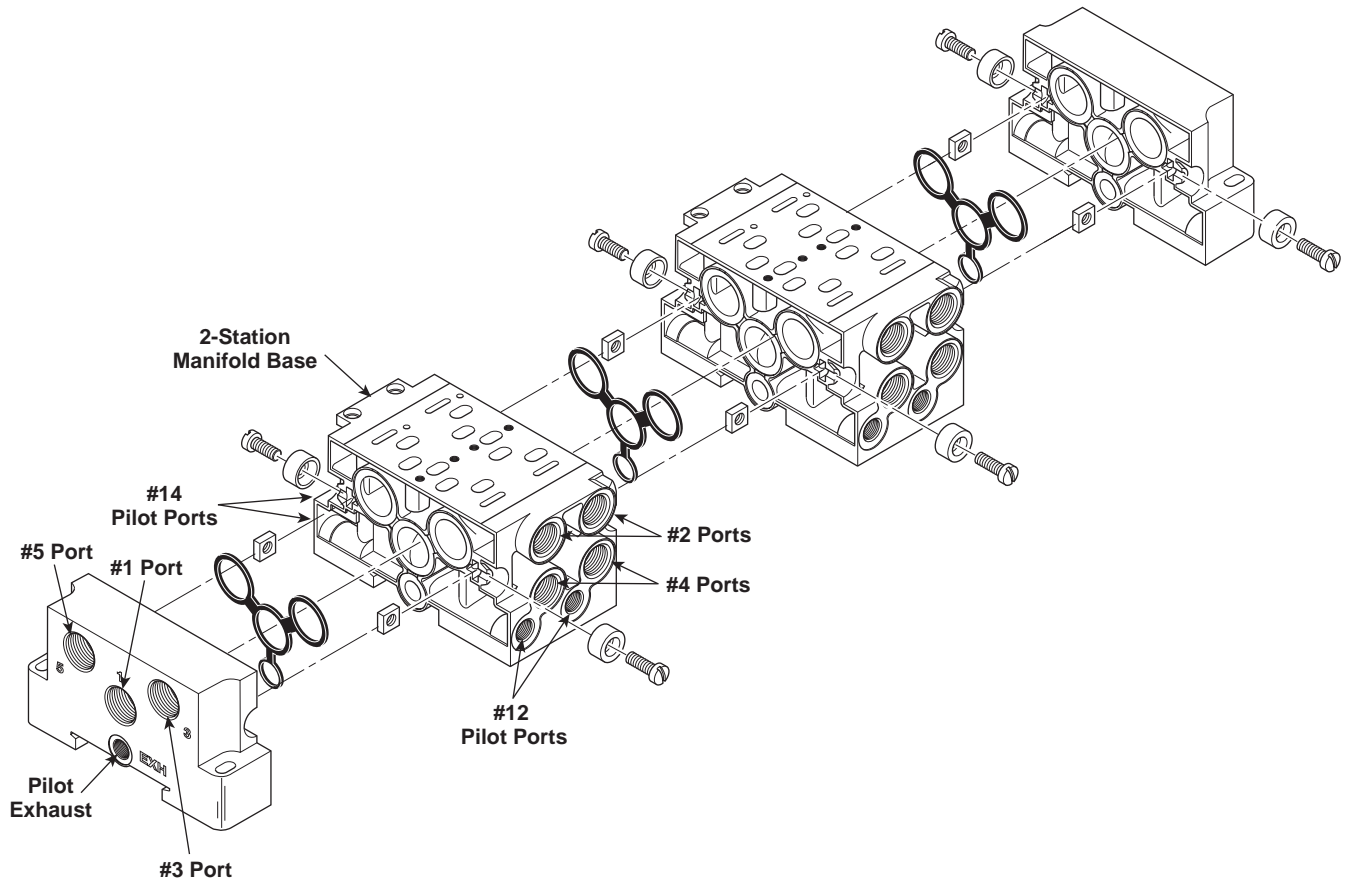

DX01 Shown

D

Subbase & Manual Valves

H Series Micro

Moduflex Series

H Series ISO

Fieldbus Systems

DX ISOMAX Series

Valvair II Series



For inventory, lead time, and kit lookup, visit www.pdnplu.com

D231

Parker Hannifin Corporation
 Pneumatic Division
 Richland, Michigan
www.parker.com/pneumatics

DX 15407-1 Size 01, Manifold Conversion Instructions

**Captured
Pilot Exhaust**

PJL01, Size 01

A Built-in 2-Position Selector converts the External Pilot Channel (12) into a Common Solenoid Pilot Exhaust Channel.

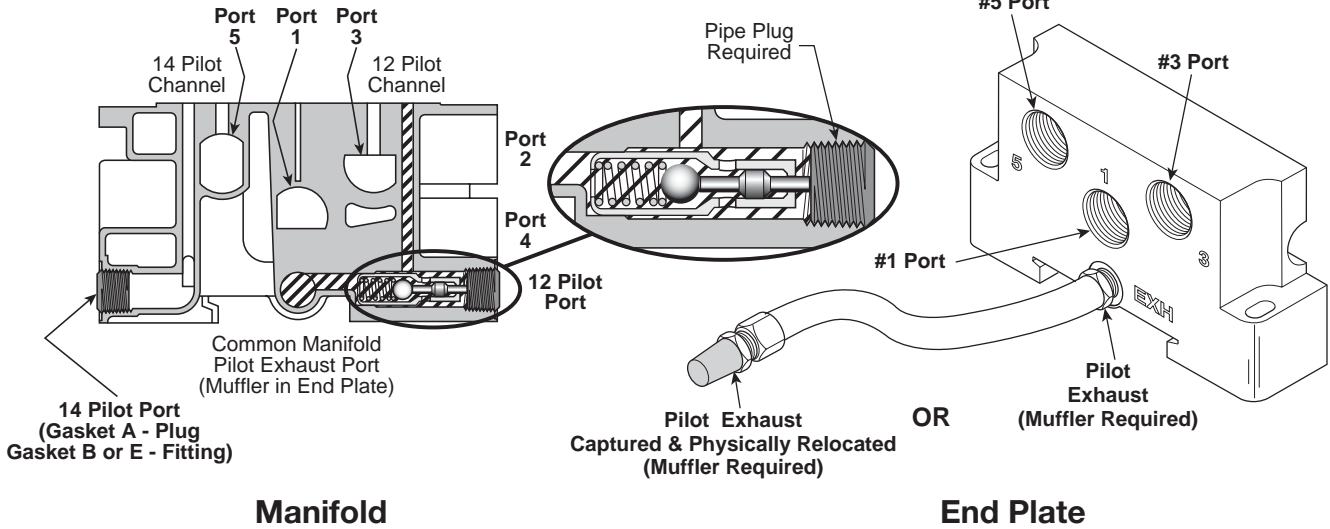

Built-in Selector

When using A, B or E **Captured** Selector Gasket Positions, the 12 Pilot Port is plugged. The 14 Pilot Port has a plug when using Gasket A or a fitting when using Gasket B or E. When in place, the Plug in the 12 Pilot Port depresses the Selector to connect the Valve Solenoid Pilot Exhaust to a Common Manifold Exhaust Port. The Plug must make contact with the Pin of the Internal Check Valve.

Insert a Muffler in the EXH Port of the End Plate.

Captured Selector Gasket Positions

When using A, B or E Selector Gasket Positions as shown in the schematic at right.

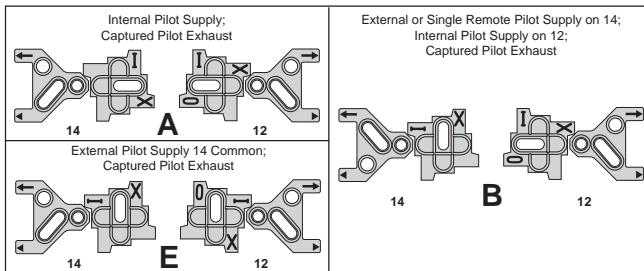

Insert a muffler or vent in the EXH Port of the PEJ02 & PEJ01 Manifold End Plates or #12 of PL02 & PL01 Subbases when using solenoids with **Captured** Pilot Exhaust.

DX01 Manifold Assembly Schematic for Captured Selector Gasket Positions A, B and E

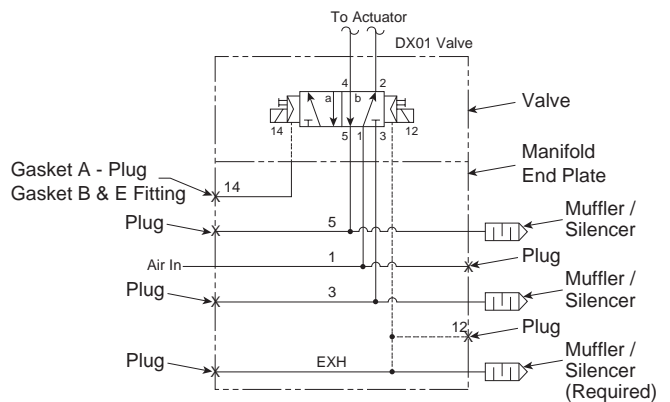

D
Subbase & Manual Valves
H Series Micro
Modulflex Series
H Series ISO
Fieldbus Systems
DX ISOMAX Series
Valvair II Series



For inventory, lead times, and kit lookup, visit www.pdnplu.com

D232

Parker Hannifin Corporation
Pneumatic Division
Richland, Michigan
www.parker.com/pneumatics

DX 15407-1 Size 01, Manifold Conversion Instructions

Vented Pilot Exhaust

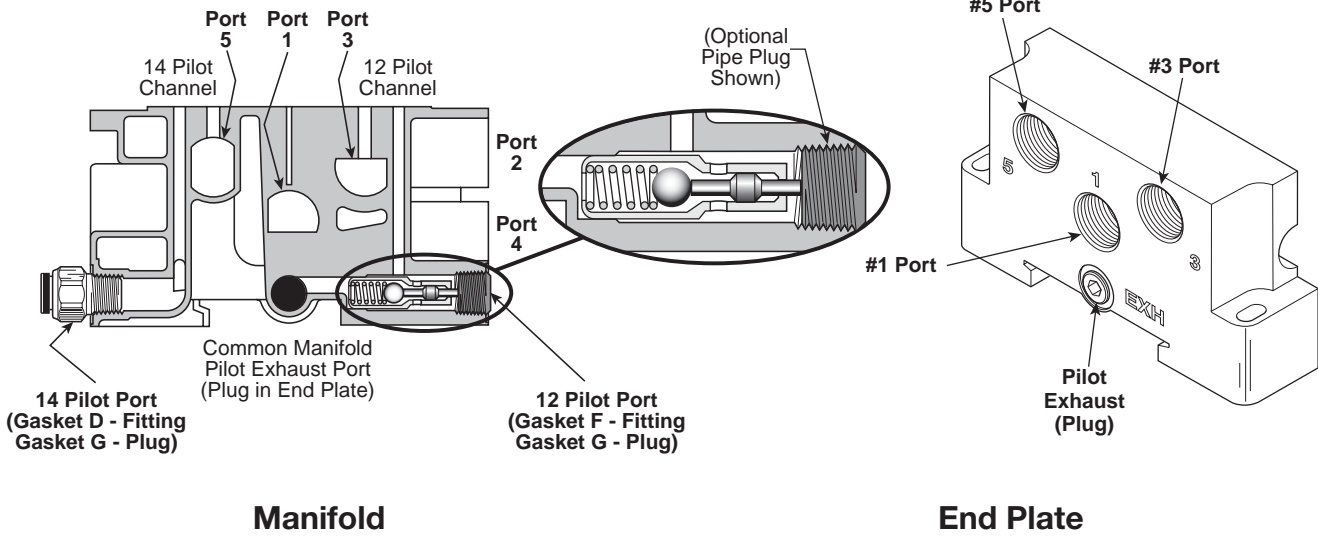

Manifold

End Plate

Built-in Selector

When using D or G **Vented** Selector Gasket Positions, the 12 Pilot Port may be plugged (Optional). The 14 Pilot Port has a plug when using Gasket G or a fitting when using Gasket D or F. The valve solenoid pilot exhaust vents out the pilot adapter on the G Gasket Selection.

Vented Selector Gasket Positions

When using D, F or G Selector Gasket Positions, pilot exhaust air is vented out the valve.

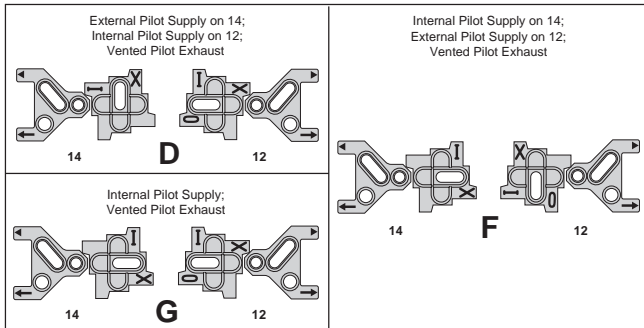

A plug may be inserted in the EXH Port of the PEJ02 & PEJ01 Manifold End Plates, #12 of PL02 & PL01 Subbases.

DX01 Manifold Assembly Schematic for Vented Selector Gasket Positions D or G

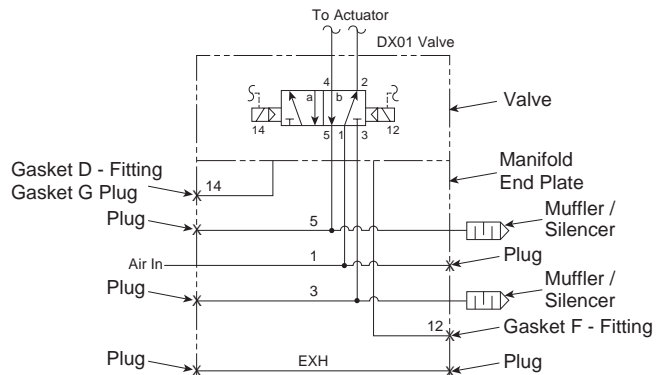

For inventory, lead time, and kit lookup, visit www.pdnplu.com

D233

Parker Hannifin Corporation
 Pneumatic Division
 Richland, Michigan
www.parker.com/pneumatics

D

Subbase & Manual Valves

H Series Micro

Moduflex Series

H Series ISO

Fieldbus Systems

DX ISOMAX Series

Valvair II Series

DX 15407-1 Size 01, Manifold Conversion Instructions

External Double Remote Pilot

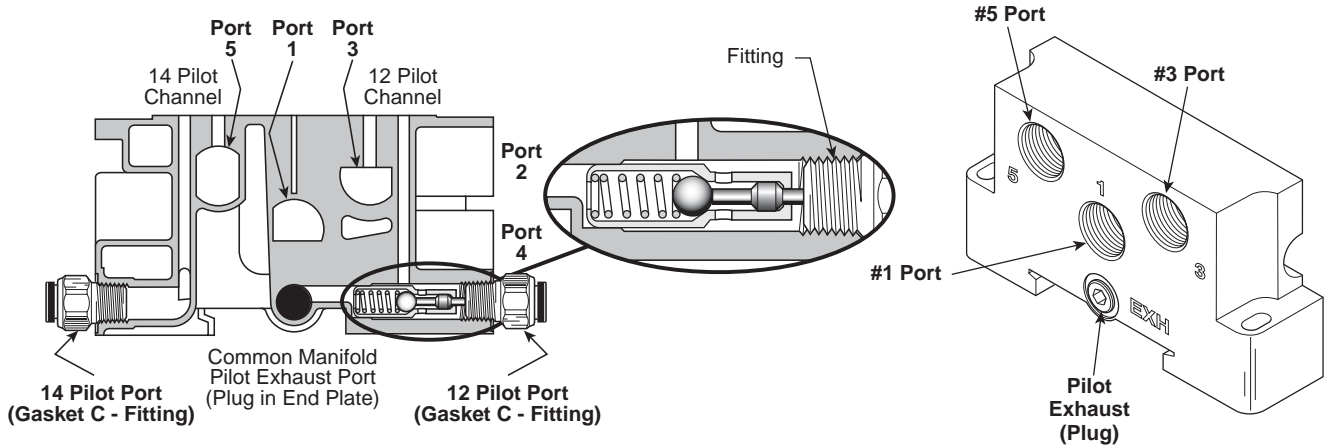

Built-in Selector

When using C **External Double Remote Pilot** Selector Gasket Position, a fitting is used in Pilot Port 14 & 12. Free flow between Port 14 & 12 and the valve allows Remote Pilot Pressure and an exhaust path for the captured pilot exhaust.

External Double Remote Pilot Selector Gasket Position

When using C Selector Gasket Position.

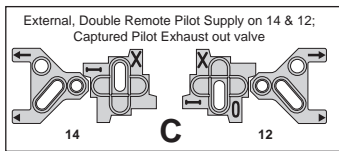

DX01 Manifold Assembly Schematic for External Double Remote Pilot Selector Gasket Position C

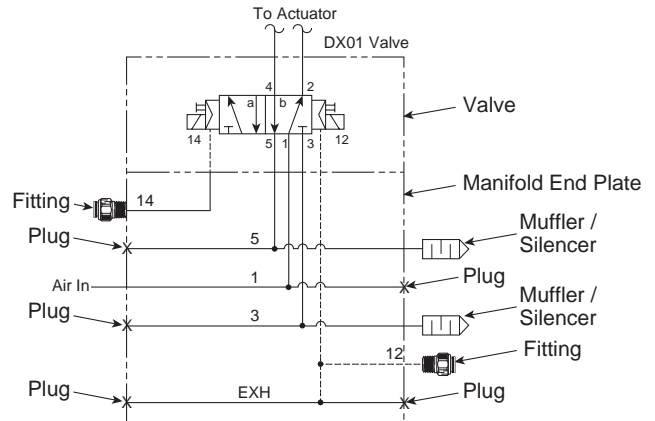

D

Subbase & Manual Valves

H Series Micro

Modulflex Series

H Series ISO

Fieldbus Systems

DX ISOMAX Series

Valvair II Series



For inventory, lead times, and kit lookup, visit www.pdnplu.com

DX02 Manifold Assembly

Ports

- 1.....Pressure
- 2.....#2 Cylinder Port, 1 to 2 Flow Path
- 3.....Cylinder Exhaust Port, 2 to 3 Flow Path
- 4.....#4 Cylinder Port, 1 to 4 Flow Path
- 5.....Cylinder Exhaust Port, 4 to 5 Flow Path
- 14.....#14 Pilot Port
- 12.....#12 Pilot Port

Torque Specifications: 25 to 35 in-lbs (2.82 to 3.95 Nm)

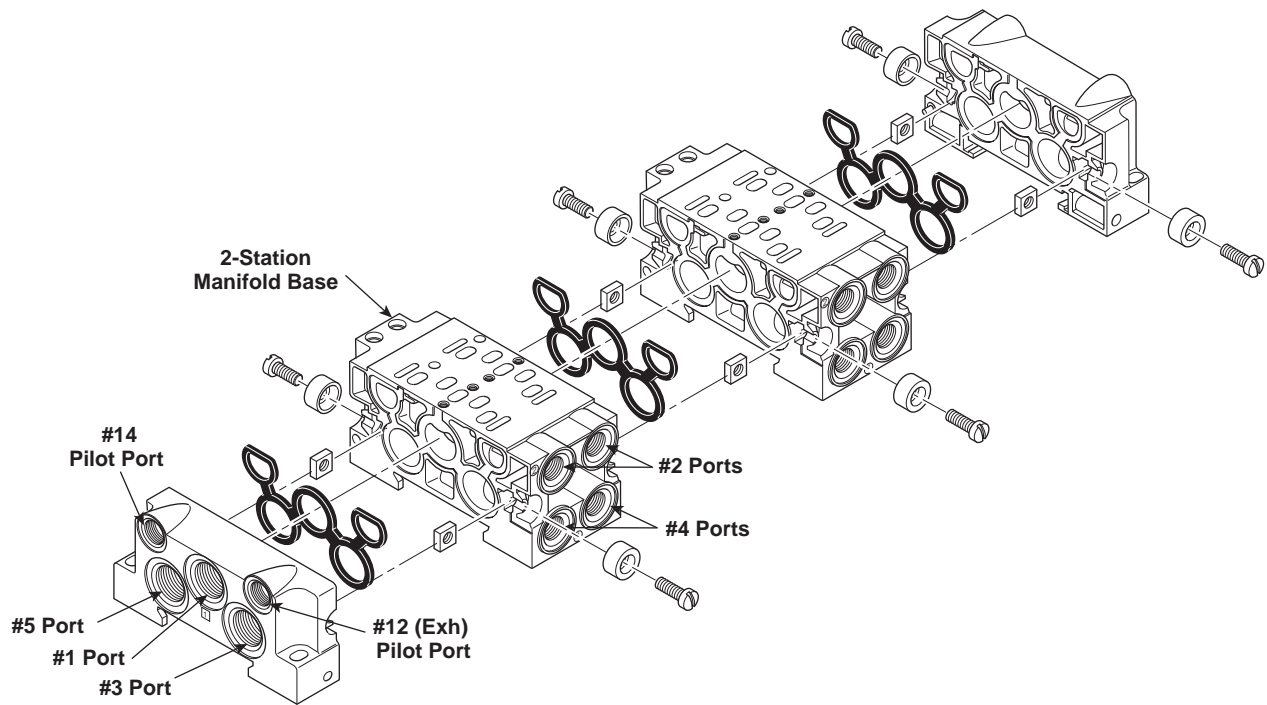

DX02 Shown

D
Subbase & Manual Valves
H Series Micro
Moduflex Series
H Series ISO
Fieldbus Systems
DX ISOMAX Series
Valvair II Series



For inventory, lead time, and kit lookup, visit www.pdnplu.com

D235

Parker Hannifin Corporation
 Pneumatic Division
 Richland, Michigan
www.parker.com/pneumatics

DX 15407-1 Size 02, Manifold Conversion Instructions

**Captured
Pilot Exhaust**

PJLP02, Size 02*

As shown in the illustrations below, the EXH (12) & 14 Pilot Ports are exhausted internally in the valve body into a single chamber labeled EXH on the end plate. When using A, B, D or E Selector Gasket Positions, the EXH (12) Pilot Port is vented with a muffler or micron screen. The 14 Pilot Port is plugged.

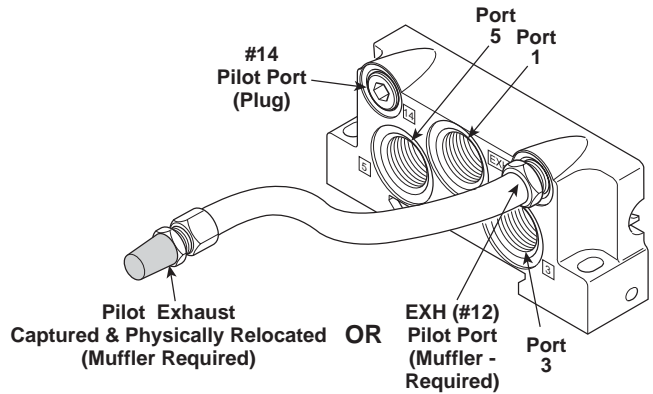
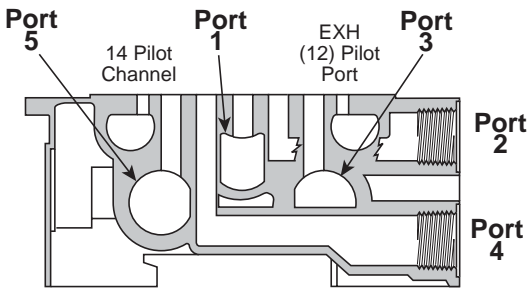

D
Subbase & Manual Valves
H Series Micro
Modulflex Series
H Series ISO
Fieldbus Systems
DX ISOMAX Series
Valvair II Series

Captured Selector Gasket Positions

When using A, B, D or E, Selector Gasket Positions, the ports must be either plugged or vented with a muffler or micron screen as shown in the schematic at right.

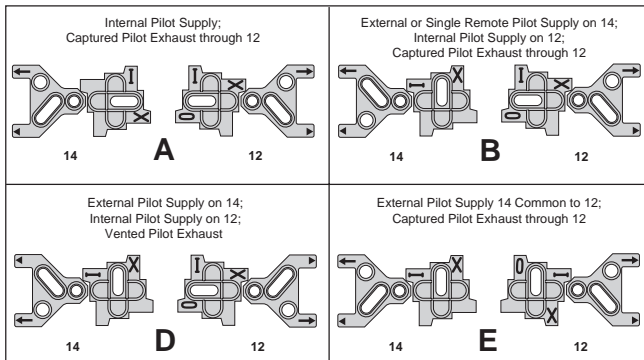

* PJLP02 Manifolds can be used for External Pilot, **NOT** Remote Pilot

DX02 Manifold Assembly Schematic for Captured Selector Gasket Positions A, B, D and E

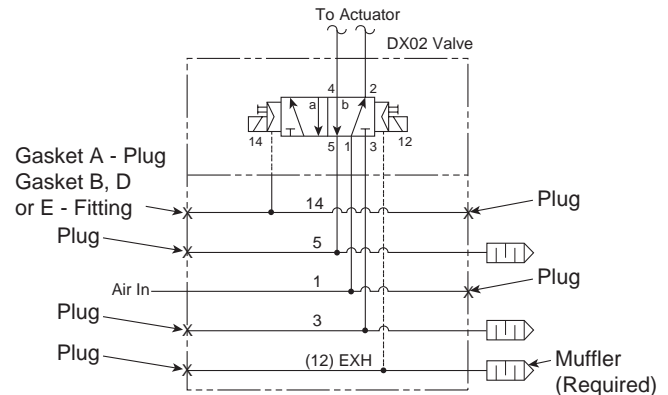

For inventory, lead times, and kit lookup, visit www.pdnplu.com

DX 15407-1 Size 02, Manifold Conversion Instructions

**Vented
 Pilot Exhaust**

PJLP02, Size 02

When using F or G Selector Gasket Positions, the EXH (12) Pilot Port and the 14 Pilot Port are plugged and the Pilot Exhaust is vented through the Pilot Adapter.

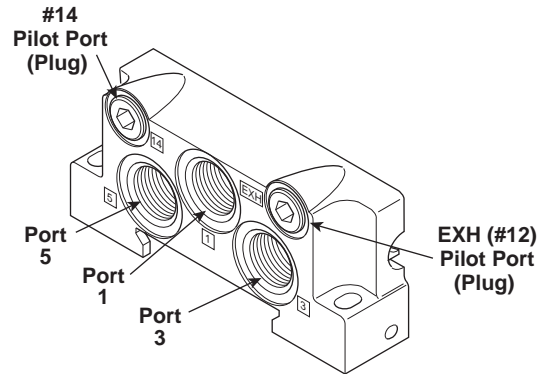
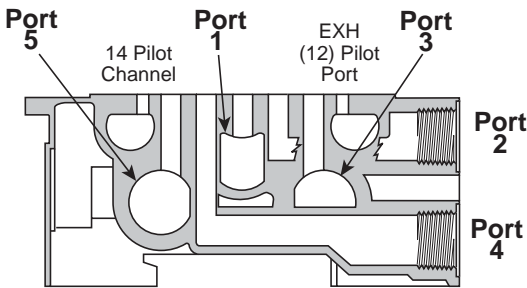

Vented Selector Gasket Positions

When using F or G, Selector Gasket Positions, the ports must be either plugged or vented with a muffler or micron screen as shown in the schematic at right.

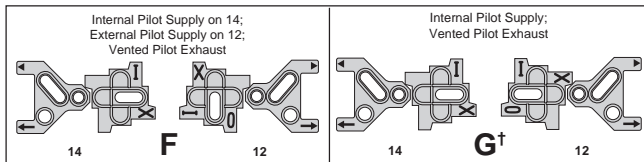

† A plug may be inserted in the EXH Port of the PEJ02 & PEJ01 Manifold End Plates or #12 of PL02 & PL01 Subbases.

**DX02 Manifold Assembly
 Schematic for Vented Selector Gasket
 Positions F and G**

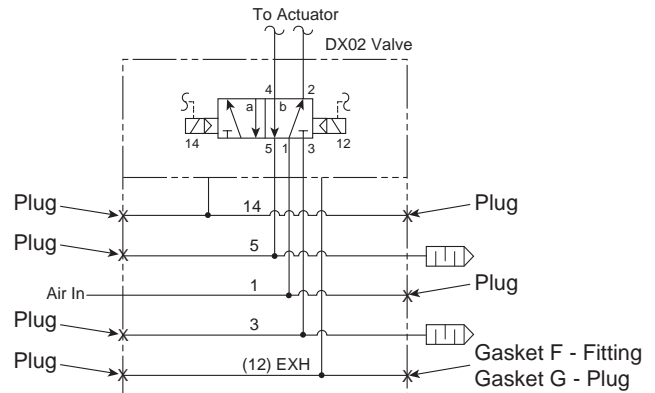

D

Subbase & Manual
 Valves

H Series
 Micro

Moduflex
 Series

H Series
 ISO

Fieldbus
 Systems

DX ISOMAX
 Series

Valvair II
 Series



For inventory, lead time, and kit lookup, visit www.pdnplu.com

D237

Parker Hannifin Corporation
 Pneumatic Division
 Richland, Michigan
www.parker.com/pneumatics

Subbase Assembly

Ports

- 1..... Pressure
- 2..... #2 Cylinder Port. 1 to 2 Flow Path.
- 3..... Cylinder Exhaust Port. 2 to 3 Flow Path.
- 4..... #4 Cylinder Port. 1 to 4 Flow Path.
- 5..... Cylinder Exhaust Port. 4 to 5 Flow Path.
- 14..... #14 Pilot Port
- 12..... #12 Pilot Port

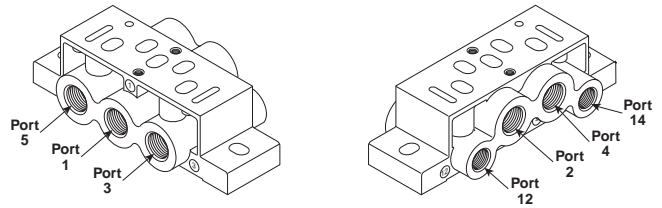

Captured Selector Gasket Positions

When using A, B, C, D or E, Selector Gasket Positions, the ports must be either plugged or vented with a muffler or micron screen as shown in the schematic at right.

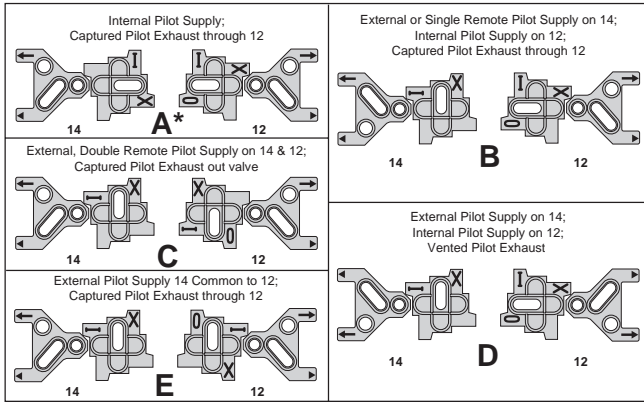

DX02 & DX01 Subbase Assembly Schematic for Captured Selector Gasket Positions A, B, C, D and E

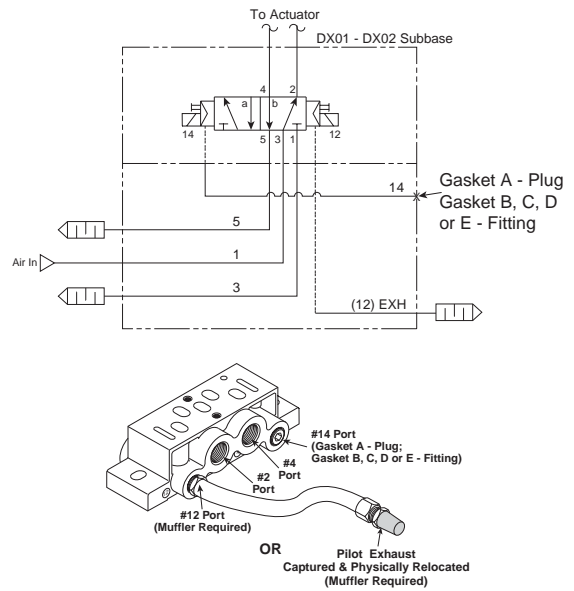

Vented Selector Gasket Positions

When using F or G, Selector Gasket Positions, the ports must be either plugged or vented with a muffler or micron screen as shown in the schematic at right.

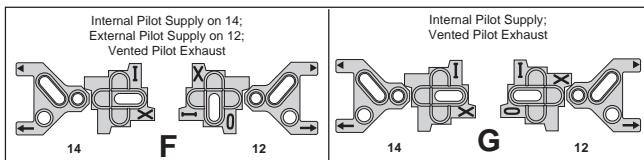

DX02 & DX01 Subbase Assembly Schematic for Vented Selector Gasket Positions F and G

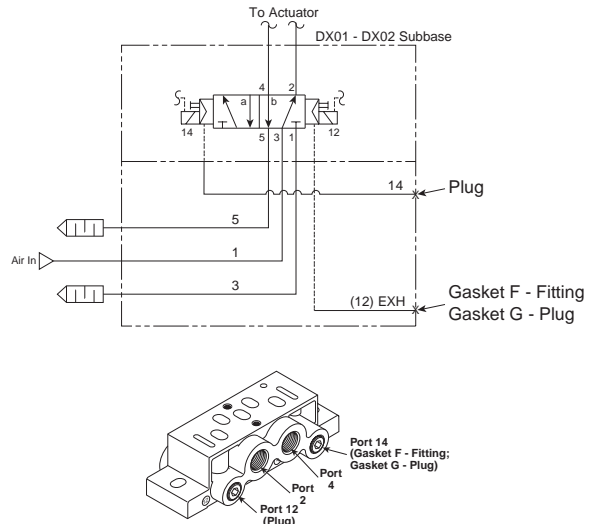

D
 Subbase & Manual Valves
 H Series Micro
 Moduteflex Series
 H Series ISO
 Fieldbus Systems
 DX ISOMAX Series
 Valvair II Series



For inventory, lead times, and kit lookup, visit www.pdnplu.com

DX1 / DX2 / DX3

Internal / External Pilot Conversion Instructions

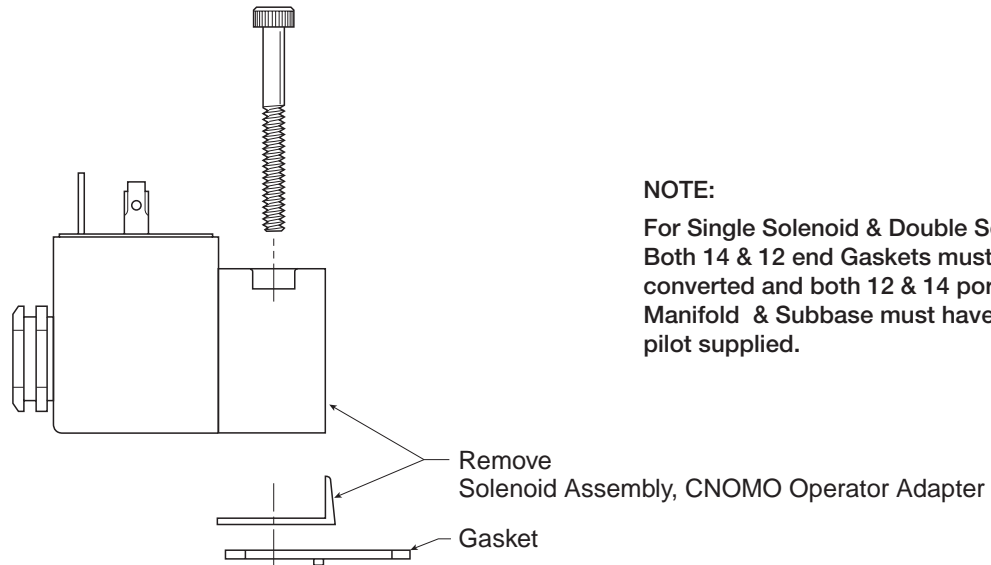

NOTE:

For Single Solenoid & Double Solenoid – Both 14 & 12 end Gaskets must be converted and both 12 & 14 ports in the Manifold & Subbase must have external pilot supplied.

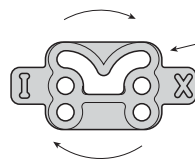
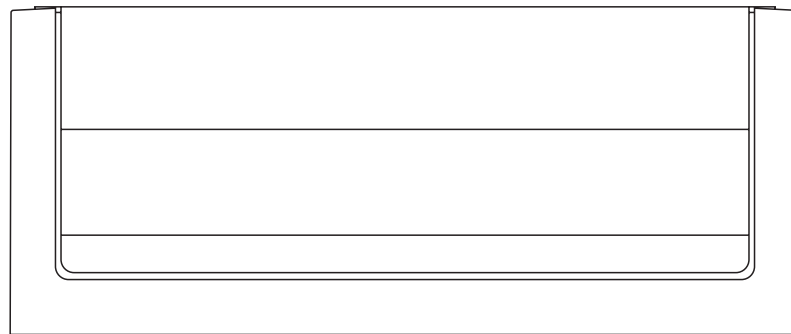

Remove Gasket and Rotate to Show "I" in Position as Shown and Reinstall Gasket and Covers. (Valve is Now External Pilot)

Position of Gasket for Internal Pilot when Using with Solenoid Operator

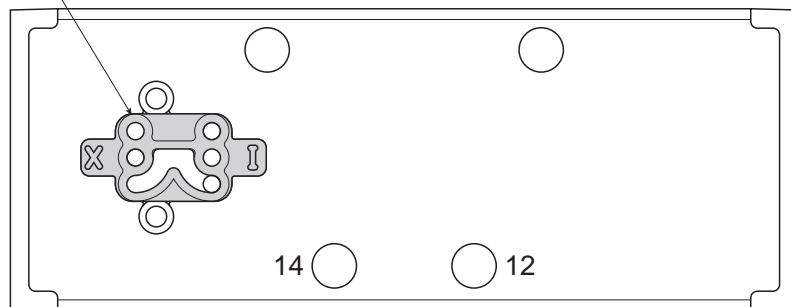

D

Subbase & Manual Valves

H Series Micro

Moduflex Series

H Series ISO

Fieldbus Systems

DX ISOMAX Series

Valvair II Series

DX1, DX2, DX3 VDMA & 5599-1 Side Ported Subbase

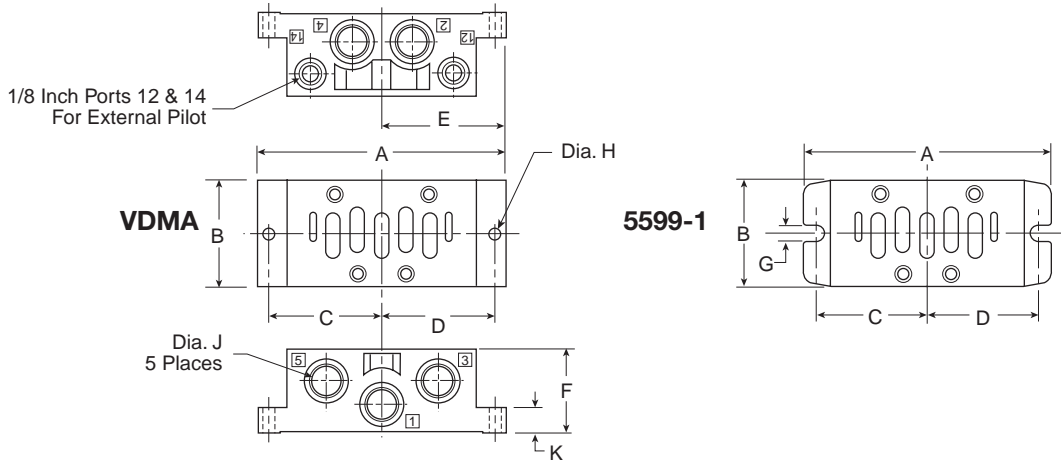

Series	Part number	J	A	B	C	D	E	F	G	H	K
VDMA	DX1 P2N-VS512SD	BSPP G1/4	4.33 (110)	1.89 (48)	1.93 (49)	1.93 (49)	2.17 (55)	1.26 (32)	—	0.22 (5.5)	0.39 (9.9)
	DX2 P2N-WS513SD	BSPP G3/8	4.88 (124)	2.21 (56)	2.21 (56)	2.21 (56)	2.44 (62)	1.57 (40)	—	0.26 (6.6)	0.51 (13)
	DX3 P2N-YS514SD	BSPP G1/2	5.87 (149)	2.80 (71)	2.68 (68)	2.68 (68)	2.93 (74.5)	2.05 (52)	—	0.26 (6.6)	0.71 (18)
5599-1	DX1 PL1-1/4-70	BSPP G1/4	4.33 (110)	1.81 (46)	1.93 (49)	1.93 (49)	2.17 (55)	1.14 (29)	0.22 (5.5)	—	0.24 (6)
	DX1 PL1-1/4-80	NPT 1/4	4.33 (110)	1.81 (46)	1.93 (49)	1.93 (49)	2.17 (55)	1.14 (29)	0.22 (5.5)	—	0.24 (6)
	DX2 PL2-3/8-70	BSPP G3/8	4.88 (124)	2.21 (56)	2.17 (55)	2.17 (55)	2.44 (62)	1.46 (37)	0.22 (5.5)	—	0.24 (6)
	DX2 PL2-3/8-80	NPT 3/8	4.88 (124)	2.21 (56)	2.17 (55)	2.17 (55)	2.44 (62)	1.46 (37)	0.22 (5.5)	—	0.24 (6)
	DX3 PL3-1/2-70	BSPP G1/2	5.87 (149)	2.80 (71)	2.68 (68)	2.68 (68)	2.93 (74.5)	2.36 (60)	0.26 (6.6)	—	0.71 (18)
	DX3 PL3-1/2-80	NPT 1/2	5.87 (149)	2.80 (71)	2.68 (68)	2.68 (68)	2.93 (74.5)	2.36 (60)	0.26 (6.6)	—	0.71 (18)

Inches (mm)

DX1, DX2 5599-1 Bottom Ported Subbase

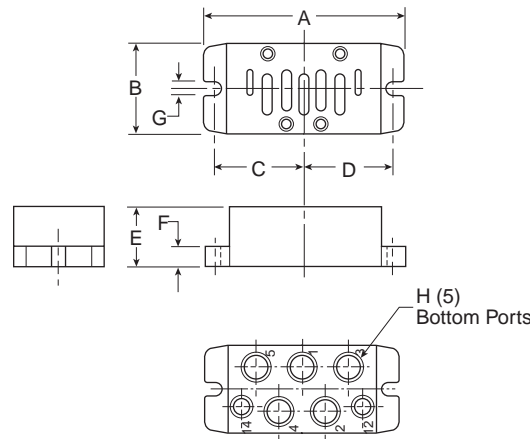

Bottom Ported Subbase

Series	Part number	H	A	B	C	D	E	F	G
DX1	PD1-1/4-70	BSPP G1/4	4.33 (110)	1.81 (46)	1.93 (49)	1.93 (49)	1.14 (29)	0.24 (6)	0.22 (5.5)
	PD1-1/4-80	NPT 1/4	4.33 (110)	1.81 (46)	1.93 (49)	1.93 (49)	1.14 (29)	0.24 (6)	0.22 (5.5)
DX2	PD2-3/8-70	BSPP G13/8	4.88 (124)	2.20 (56)	2.17 (55)	2.17 (55)	1.46 (37)	0.24 (6)	0.22 (5.5)
	PD2-3/8-80	NPT 3/8	4.88 (124)	2.20 (56)	2.17 (55)	2.17 (55)	1.46 (37)	0.24 (6)	0.22 (5.5)

Inches (mm)

D
 Subbase & Manual Valves
 H Series Micro
 Modutrex Series
 H Series ISO
 Fieldbus Systems
 DX ISOMAX Series
 Valvair II Series



For inventory, lead times, and kit lookup, visit www.pdnplu.com

D240

Parker Hannifin Corporation
 Pneumatic Division
 Richland, Michigan
www.parker.com/pneumatics

DX01 & DX02 Valve

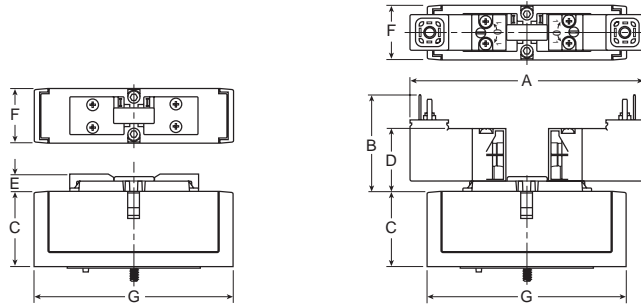

Series	A	B	C	D	E	F	G
DX02	4.06 (103)	1.61 (41)	1.41 (36)	1.06 (27)	.31 (8)	.71 (18)	3.15 (80)
DX01	4.06 (103)	1.61 (41)	1.41 (36)	1.06 (27)	.31 (8)	1.02 (26)	3.94 (100)

Inches (mm)

DX01 & DX02 Individual Subbase

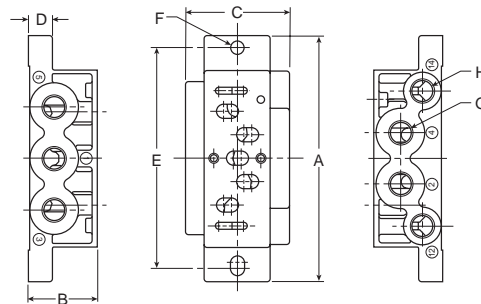

Series	Part number	A	B	C	D	E	F	G	H
DX02	PL02	3.15 (80)	.87 (22)	1.06 (27)	.31 (8)	2.76 (70)	.216 Dia. (Ø 5.5)	1/8	M5
DX01	PL01	3.94 (100)	1.10 (28)	1.65 (42)	.39 (10)	3.54 (90)	.216 Dia. (Ø 5.5)	1/4	1/8

Inches (mm)

DX01 & DX02 2-Station Manifold Base

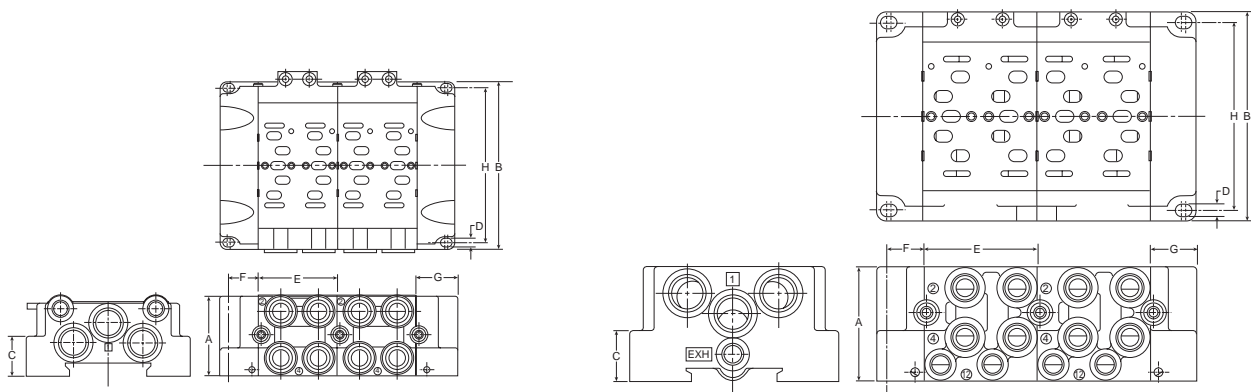

Series	Part number	A	B	C	D	E	F	G	H
DX02	PJLP02 / PEJ02	1.52 (38.5)	3.15 (80)	.47 (12)	.165 Dia. (Ø 4.2)	1.50 (38)	.55 (14)	.71 (18)	2.83 (72)
DX01	PJL01 / PJLP01 / PEJ01	2.17 (55)	3.94 (100)	.94 (24)	.216 Dia. (Ø 5.5)	2.13 (54)	.67 (17)	.87 (22)	3.54 (90)

Inches (mm)



For inventory, lead time, and kit lookup, visit www.pdnplu.com

D241

Parker Hannifin Corporation
 Pneumatic Division
 Richland, Michigan
www.parker.com/pneumatics

D

Subbase & Manual Valves

H Series Micro

Moduflex Series

H Series ISO

Fieldbus Systems

DX ISOMAX Series

Valvair II Series

DX01 15407-1, PS5511 Subbases

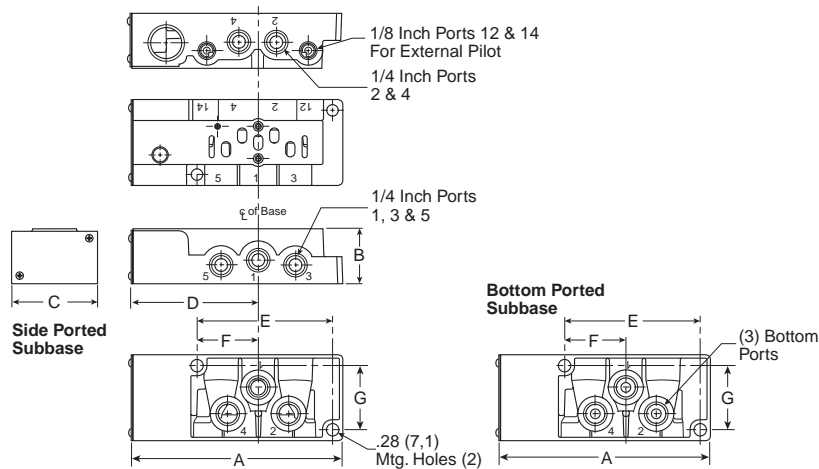

PS5511 Subbase

A	B	C	D
4.88 (124)	1.28 (32.5)	2.00 (50.8)	2.91 (74)
E	F	G	
1.43 (36.2)	3.16 (80.2)	1.49 (37.9)	

Inches (mm)

DX02 & DX01 15407-1, PS5611 & PS5511 Manifolds

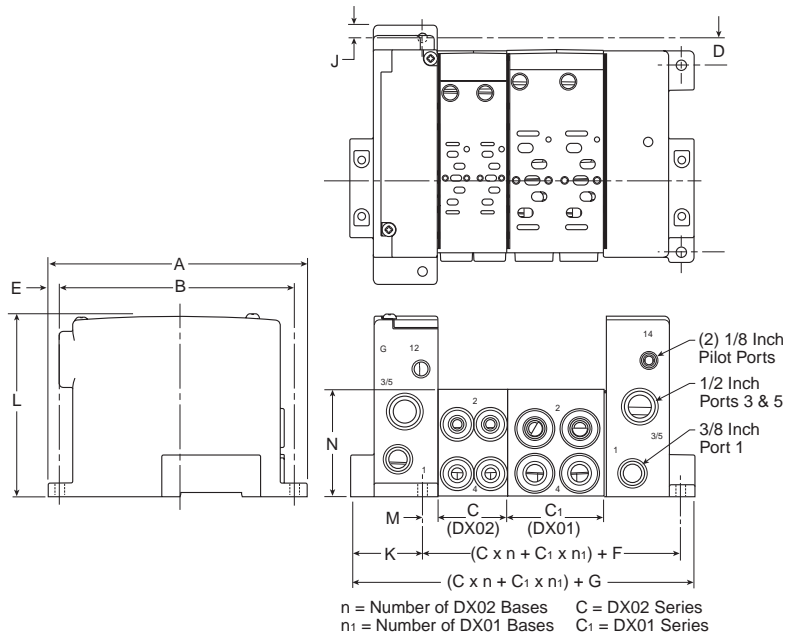

PS5611 & PS5511 Manifolds

A	B	C	C ₁
5.98 (152)	5.39 (137)	1.61 (40.8)	2.24 (56.8)
D	E	F	G
.63 (16)	.30 (7.5)	2.14 (54.4)	4.12 (104.6)
H	J	K	L
4.32 (109.8)	.15 (4)	1.68 (42.7)	4.17 (106)
M	N		
.33 (8.4)	2.48 (63)		

Inches (mm)

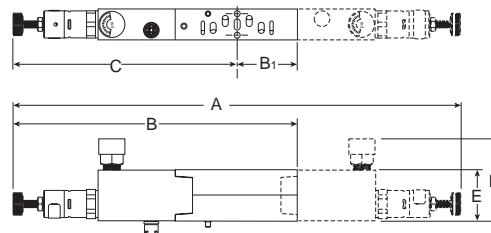

Series	Part number	A	B	B1	C	D	E
DX02	PS5637	10.28 (261)	6.14 (156)	1.02 (26)	5.13 (130)	2.60 (66)	1.18 (30)
DX01	PS5537	10.00 (254)	6.42 (163)	1.42 (36)	5.00 (127)	2.72 (69)	1.18 (30)

Inches (mm)

D
 Subbase & Manual Valves
 H Series Micro
 Modulflex Series
 H Series ISO
 Fieldbus Systems
 DX ISOMAX Series
 Valvair II Series



For inventory, lead times, and kit lookup, visit www.pdnplu.com

D242

Parker Hannifin Corporation
 Pneumatic Division
 Richland, Michigan
www.parker.com/pneumatics

DX1, DX2 & DX3 Air Operated Valve

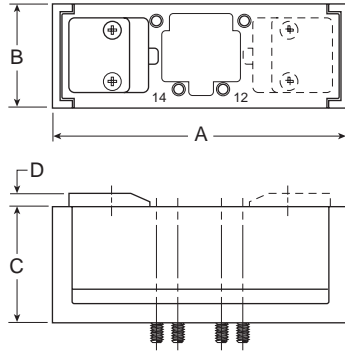

Series	A	B	C	D
DX1	4.72 (120)	1.65 (42)	1.85 (47)	.20 (5)
DX2	5.51 (140)	2.13 (54)	2.30 (58.5)	.20 (5)
DX3	6.69 (170)	2.68 (68)	2.80 (71)	.20 (5)

Inches (mm)

DX1, DX2 & DX3 Solenoid Operated Valve

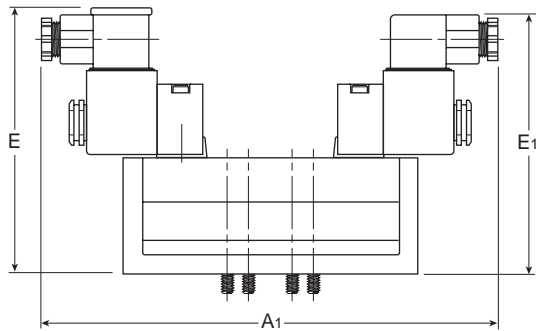

Series	A1	E	E1	E2
DX1	7.97 (202.5)	4.43 (112.5)	4.69 (119)	4.53 (115)
DX2	8.58 (218)	4.86 (123.5)	5.12 (130)	4.98 (126.5)
DX3	9.27 (235.5)	5.35 (136)	5.61 (142.5)	5.47 (139)

Inches (mm)

D

Subbase & Manual
Valves

H Series
Micro

Moduflex
Series

H Series
ISO

Fieldbus
Systems

**DX ISOMAX
Series**

Valvair II
Series



DX1 Subbase

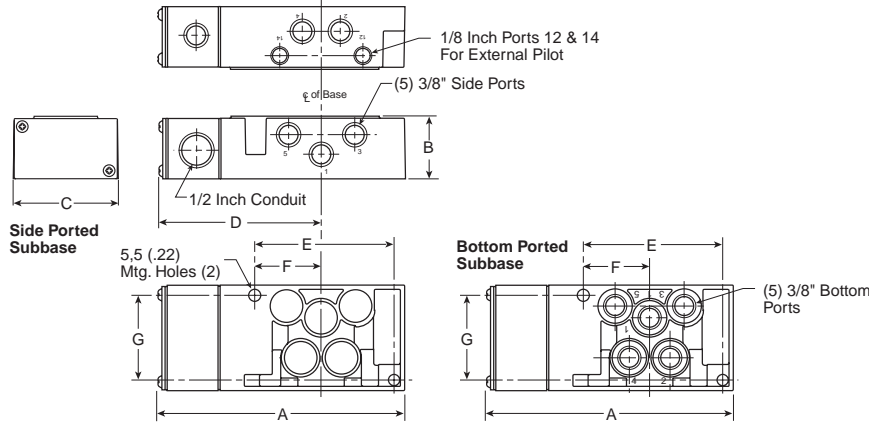

PS4011 Subbase

A	B	C	D
5.83	1.48	2.50	3.86
(148)	(38)	(64)	(98)
E	F	G	
3.29	1.57	2.00	
(84)	(40)	(51)	

Inches (mm)

DX2 Subbase

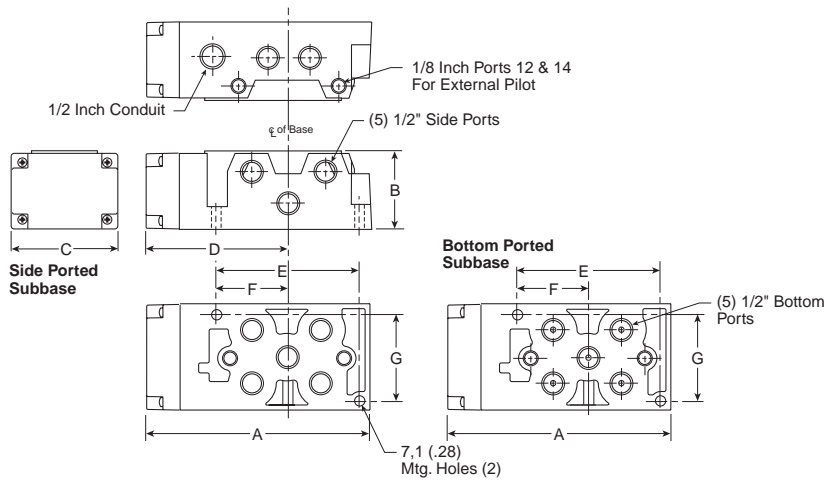

PS4111 Subbase

A	B	C	D
6.69	2.33	3.15	4.25
(170)	(59)	(80)	(108)
E	F	G	
4.21	2.07	2.56	
(107)	(52)	(65)	

Inches (mm)

DX3 Subbase

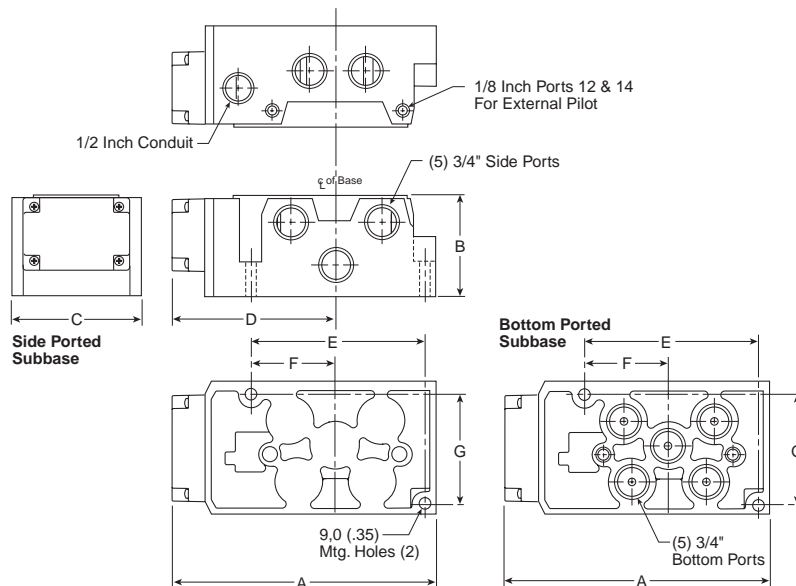

PS4211 Subbase

A	B	C	D
7.90	2.96	3.90	4.92
(201)	(75)	(990)	(125)
E	F	G	
5.14	2.50	3.24	
(131)	(64)	(82)	

Inches (mm)

D
 Subbase & Manual
 Valves
 H Series
 Micro
 Modutrex
 Series
 H Series
 ISO
 Fieldbus
 Systems
 DX ISOMAX
 Series
 Valvair II
 Series



For inventory, lead times, and kit lookup, visit www.pdnplu.com

D244

Parker Hannifin Corporation
 Pneumatic Division
 Richland, Michigan
www.parker.com/pneumatics

DX1 Manifold

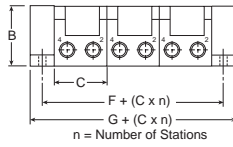
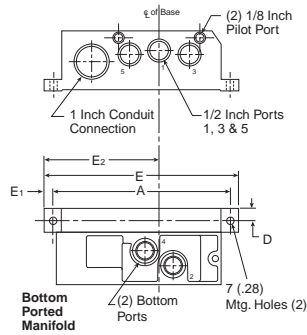

PS4011 Manifold

A	B	C	D	E
6.50 (165)	2.20 (56)	1.93 (49)	.44 (11)	7.15 (182)
E1	E2	F	G	
.33 (8)	4.25 (108)	.87 (22)	1.80 (46)	

Inches (mm)

DX2 Manifold

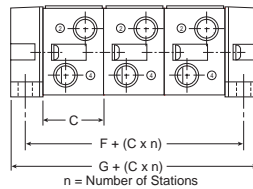
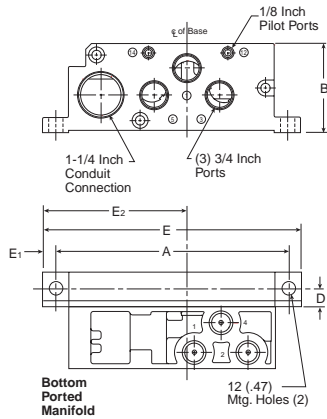

PS4111 Manifold

A	B	C	D	E
8.46 (215)	3.35 (85)	2.20 (56)	.59 (15)	9.41 (239)
E1	E2	F	G	
.47 (12)	5.28 (134)	1.18 (30)	2.36 (60)	

Inches (mm)

DX3 Manifold

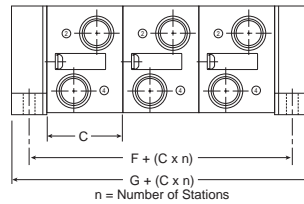
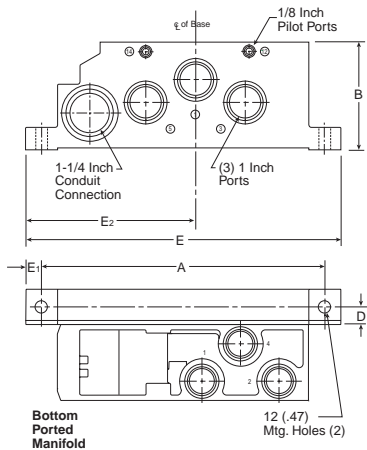

PS4211 Manifold

A	B	C	D	E
10.41 (265)	4.13 (105)	2.80 (71)	.65 (175)	11.61 (295)
E1	E2	F	G	
.59 (15)	6.26 (159)	1.30 (33)	2.60 (63)	

Inches (mm)



For inventory, lead time, and kit lookup, visit www.pdnplu.com

D245

Parker Hannifin Corporation
 Pneumatic Division
 Richland, Michigan
www.parker.com/pneumatics

D

Subbase & Manual Valves

H Series Micro

Moduflex Series

H Series ISO

Fieldbus Systems

DX ISOMAX Series

Valvair II Series

DX1, DX2, DX3 5599-1 VDMA

Form C Manifold &
 Form D End Plates

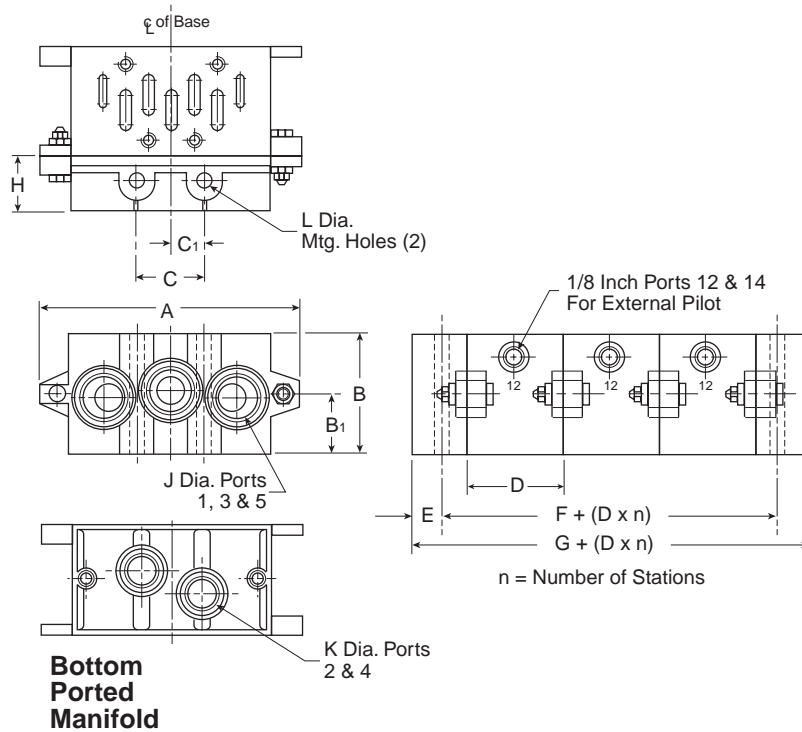

VDMA Form C Manifold

Series	Part number	A	B	B1	D	E	F	G	J	K
DX1	P2N-VM512MB	4.33 (110)	1.81 (46)	0.94 (24)	1.69 (55)	0.43 (22)	0.87 (22)	1.73 (44)	BSPP G3/8	BSPP G1/4
DX2	P2N-WM513MB	5.31 (135)	1.85 (47)	0.94 (24)	2.20 (56)	0.51 (13)	1.02 (26)	2.05 (52)	BSPP G1/2	BSPP G3/8
DX3	P2N-YM514MB	7.48 (190)	2.20 (56)	1.34 (34)	2.80 (71)	0.59 (15)	1.18 (30)	2.36 (60)	BSPP G1/2	BSPP G1/2

VDMA Form D End Plate

Series	Part number	A	B	B1	C	C1	H	L
DX1	P2N-VM513ES	4.33 (110)	1.81 (46)	0.94 (24)	1.10 (28)	0.55 (14)	0.87 (22)	0.28 (7)
DX2	P2N-WM514ES	5.31 (135)	1.85 (47)	0.94 (24)	1.38 (35)	0.69 (18)	1.02 (26)	0.34 (9)
DX3	P2N-YM518ES	7.48 (190)	2.20 (56)	1.34 (34)	2.05 (52)	1.03 (26)	1.18 (30)	0.47 (12)

Inches (mm)

D
 Subbase & Manual Valves
 H Series Micro
 Moduteflex Series
 H Series ISO
 Fieldbus Systems
 DX ISOMAX Series
 Valvair II Series



For inventory, lead times, and kit lookup, visit www.pdnplu.com

D246

Parker Hannifin Corporation
 Pneumatic Division
 Richland, Michigan
www.parker.com/pneumatics

Valvair II Series

- Full air operation for fastest response
- “Plug-in” option simplifies maintenance and installation
 Reduces downtime. No wiring or plumbing to disturb
- “Direct pipe” design for economy and performance
- Variety of operators available; direct conduit, (JIC) junction box, NEMA 4, hazardous duty, (UL, CSA), and remote air pilot
- Field convertible to external pilot supply for vacuum or other services
- Synthetic rubber o-ring seals are specially compounded for minimum compression and friction for superior wear and abrasion resistance
- Precision ground spool “floats” on o-ring seals. Closed center cross-over design saves air
- General Purpose Approvals
 - CSA - Canadian Standards Association
 File number 42024
- Hazardous Duty Approvals
 - UL - Underwriters Laboratories, Inc.
 File number E42542 Category Y107
 - CSA - Canadian Standards Association
 File number 24349

Material specifications

Manifolds & subbases	Aluminum alloy	
Other seals	Nitrile	
Resilient seals: in valve body		
Dynamic	Polyurethane base on 3/8" basic valves*	
Static / dynamic	Nitrile base w / 12% Molybdenum Disulphide on 1/4" & 1/2" basic valves	
Shock pads	Polyurethane	
Solenoid bodies	Plated zinc alloy	
Internal components	Corrosion resistant steel	
Resilient seals	Standard service	Nitrile
	Special service (continuous duty)	Fluorocarbon & Silicone
Other seals	Nitrile	
Coil	Class “B” epoxy encapsulated (Class “H” also available on some models, consult supplier)	
Valve bodies	Aluminum alloy	
Valve spacers	Brass	
Valve spool	Aluminum alloy with special coating on 3/8" basic valves*. Hard chrome plated AISI type 416 stainless steel on 1/4" & 1/2" basic valves.	

* These materials are specially designed for valves used on non-lubricated service

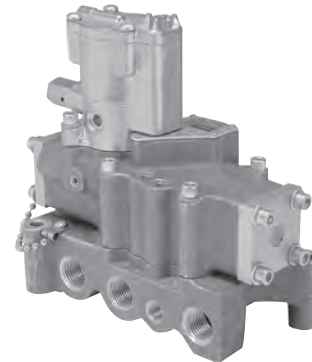

Operating information

Pressure range for solenoid operated valves

Media	Internal pilot supply			External pilot supply			
	1/4"	3/8"	1/2"	1/4"	3/8"	1/2"	1"
Air	35-140* PSIG			N.A. Main	0-250 PSIG		
				Pilot	35-140* PSIG		
Vacuum	do not use			N.A. Main	within 1 Hg of perfect		
				Pilot	35-140* PSIG		

Other Consult supplier

* 200 PSIG solenoid is optional (consult supplier).

Pressure range for remote pilot operated valves

Media		Valve type	
		Single	Double & 3-position
Air	Main	35-250 PSIG	0-250 PSIG
	Pilot	35-200 PSIG	35-200 PSIG
Vacuum	Main	Do not use	Within 1" Hg of perfect
	Pilot	Do not use	35-200 PSIG
Other	Consult supplier		

Ambient temperature – standard service solenoid operator

Minimum	Maximum	
	Intermittent duty	Continuous duty
0°F	125°F	100°F

Special service (continuous duty) solenoid operator
 0°F 125°F 125°F

Ambient temperature – remote pilot operated valves

0°F	200°F
-----	-------

As the above chart indicates, Standard Duty Solenoids may be used on continuous duty but ambient temperature is de-rated.
 In some cases, Special Service Solenoids may be rated for higher ambient temperatures (consult supplier).



CAUTION:

If it is possible that the ambient temperature may fall below freezing, the medium must be moisture free to prevent internal damage and unpredictable behavior.

Most popular.



For inventory, lead time, and kit lookup, visit www.pdnplu.com

D247

Parker Hannifin Corporation
 Pneumatic Division
 Richland, Michigan
www.parker.com/pneumatics

D

Subbase & Manual Valves

H Series Micro

Moduflex Series





H Series ISO

Fieldbus Systems

DX ISOMAX Series



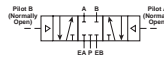

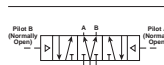
Valvair II Series

3/8" Basic plug-in solenoid valve only with light

Symbol	Type	Cv	Operator	Voltage	Non-locking	Locking
	4-way, 2-position, spring return	4.8	Single solenoid	24 VDC 110 VAC	L6753810249 L6753810253	L6753910249 L6753910253
	4-way, 2-position	4.8	Double solenoid	24 VDC 110 VAC	L6553810249 L6553810253	L6553910249 L6553910253
	4-way, 3-position, all ports blocked	4.8	Double solenoid	24 VDC 110 VAC	L6653821149 L6653821153	L6653921149 L6653921153
	4-way, 3-position, center exhaust	4.8	Double solenoid	24 VDC 110 VAC	L6653822149 L6653822153	L6653922149 L6653922153
	4-way, 3-position, pressure center	4.8	Double solenoid	24 VDC 110 VAC	L6653823149 L6653823153	L6653923149 L6653923153



* Order subbase or manifold separately.

3/8" Basic plug-in remote pilot valve only

Symbol	Type	Cv	Operator	Part number
	4-way, 2-position, spring return	4.8	Single remote	L67431102
	4-way, 2-position	4.8	Double remote	L65431102
	4-way, 3-position, all ports blocked	4.8	Double remote	L66431211
	4-way, 3-position, center exhaust	4.8	Double remote	L66431221
	4-way, 3-position, pressure center	4.8	Double remote	L66431231

* Order subbase or manifold separately.

3/8" Valve Subbase and Manifolds

	Cv	Port	Subbase † (side ports)	Manifolds † (end & bottom ports)
 Subbase	4.8	3/8"	K022090	K142230
	4.8	1/2"	K022091	K142231
 Manifold	4.8	3/4"	K022101	K142270

† Manifolds include mounting hardware, except for port adapters. Subbase includes valve mounting hardware.

Plug-in Subbase, 3/8" Basic

K022090Inlet & Cylinder Ports 3/8" NPTF
	Exhaust Ports 1/2" NPTF
K022091Inlet & Cylinder Ports 1/2" NPTF
	Exhaust Ports 1/2" NPTF
K022101Inlet & Cylinder Ports 3/4" NPTF
	Exhaust port 3/4" NPTF
	Conduit port 1/2" NPTF

Note: Subbase assemblies include mounting hardware.

 Most popular.

Plug-in Manifold, 3/8" Basic

K142230Cylinder ports 3/8" NPTF
K142231Cylinder ports 1/2" NPTF
K142270Cylinder ports 3/4" NPTF
	Exhaust port..... 1" NPTF
	Inlet port..... 1" NPTF
	Conduit port..... 1-1/4" NPTF

Note: Manifold assemblies include mounting hardware.

D
 Subbase & Manual Valves
 H Series Micro
 Modulflex Series
 H Series ISO
 Fieldbus Systems
 DX ISOMAX Series
 Valvair II Series







For inventory, lead times, and kit lookup, visit www.pdnplu.com

D248

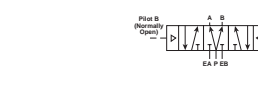

Parker Hannifin Corporation
 Pneumatic Division
 Richland, Michigan
www.parker.com/pneumatics

1" Basic plug-in solenoid valve only with light

Symbol	Type	Cv	Operator	Voltage	Non-locking	Locking
	4-way, 2-position, spring return	11.3	Single solenoid	24 VDC 110 VAC	L6758810249 L6758810253	L6758910249 L6758910253
	4-way, 2-position	11.3	Double solenoid	24 VDC 110 VAC	L6558810249 L6558810253	L6558910249 L6558910253
	4-way, 3-position, all ports blocked	11.3	Double solenoid	24 VDC 110 VAC	L6658821149 L6658821153	L6658921149 L6658921153
	4-way, 3-position, center exhaust	11.3	Double solenoid	24 VDC 110 VAC	L6658822149 L6658822153	L6658922149 L6658922153
	4-way, 3-position, pressure center	11.3	Double solenoid	24 VDC 110 VAC	L6658823149 L6658823153	L6658923149 L6658923153

* Order subbase separately.

1" Basic plug-in valve remote pilot valve only

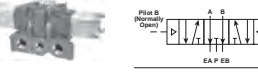
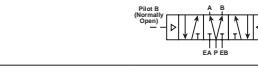
Symbol	Type	Cv	Operator	Part number
	4-way, 2-position, spring return	11.3	Single remote	L67481102
	4-way, 2-position	11.3	Double remote	L65481102
	4-way, 3-position, all ports blocked	11.3	Double remote	L66481211
	4-way, 3-position, center exhaust	11.3	Double remote	L66481221
	4-way, 3-position, pressure center	11.3	Double remote	L66481231

* Order subbase separately.

1" Valve Subbase

	Cv	Port	Subbase † (side ports)
	11.3	1"	K022095

Subbase

† Subbase includes valve mounting hardware.

Plug-in Manifold, 1" Basic

K0220905 Inlet & Cylinder Ports 1" NPTF
Exhaust Ports 1-1/4" NPTF
Conduit port 1/2" NPTF

Note: Subbase assemblies include mounting hardware.



For inventory, lead time, and kit lookup, visit www.pdnplu.com

D249

Parker Hannifin Corporation
Pneumatic Division
Richland, Michigan
www.parker.com/pneumatics

D

Subbase & Manual Valves

H Series Micro

Moduflex Series

H Series ISO

Fieldbus Systems

DX ISOMAX Series

Valvair II Series

3/8" Basic direct pipe ported valve only. Solenoid junction box with light, 1/2" NPT ports

Symbol	Type	Cv	Operator	Voltage	Non-locking	Locking
	4-way, 2-position, spring return	4.8	Single solenoid	24 VDC 110 VAC	L7054810249 L7054810253	L7054910249 L7054910253
	4-way, 2-position	4.8	Double solenoid	24 VDC 110 VAC	L6854810249 L6854810253	L6854910249 L6854910253
	4-way, 3-position, all ports blocked	4.8	Double solenoid	24 VDC 110 VAC	L6954821149 L6954821153	L6954921149 L6954921153
	4-way, 3-position, center exhaust	4.8	Double solenoid	24 VDC 110 VAC	L6954822149 L6954822153	L6954922149 L6954922153
	4-way, 3-position, pressure center	4.8	Double solenoid	24 VDC 110 VAC	L6954823149 L6954823153	L6954923149 L6954923153

3/8" Basic direct pipe ported remote pilot valve only, 1/2" NPT ports

Symbol	Type	Cv	Operator	Part number
	4-way, 2-position, spring return	4.8	Single remote	L70441102
	4-way, 2-position	4.8	Double remote	L68441102
	4-way, 3-position, all ports blocked	4.8	Double remote	L69441211
	4-way, 3-position, center exhaust	4.8	Double remote	L69441221
	4-way, 3-position, pressure center	4.8	Double remote	L69441231

D
Subbase & Manual Valves
H Series Micro
Modutefx Series
H Series ISO
Fieldbus Systems
DX ISOMAX Series
Valvair II Series

Most popular.







For inventory, lead times, and kit lookup, visit www.pdnplu.com



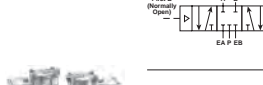

D250

Parker Hannifin Corporation
Pneumatic Division
Richland, Michigan
www.parker.com/pneumatics

1" Basic direct pipe ported valve only. Solenoid junction box with light, 1" NPT ports

Symbol	Type	Cv	Operator	Voltage	Non-locking	Locking
	4-way, 2-position, spring return	11.3	Single solenoid	24 VDC 110 VAC	L7058810249	L7058910249
	4-way, 2-position	11.3	Double solenoid	24 VDC 110 VAC	L6858810249	L6858910249
	4-way, 3-position, all ports blocked	11.3	Double solenoid	24 VDC 110 VAC	L6958821149	L6958921149
	4-way, 3-position, center exhaust	11.3	Double solenoid	24 VDC 110 VAC	L6958822149	L6958922149
	4-way, 3-position, pressure center	11.3	Double solenoid	24 VDC 110 VAC	L6958823149	L6958923149

1" Basic direct pipe ported remote pilot valve only. 1" NPT ports

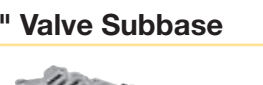
Symbol	Type	Cv	Operator	Part number
	4-way, 2-position, spring return	11.3	Single remote	L70481102
	4-way, 2-position	11.3	Double remote	L68481102
	4-way, 3-position, all ports blocked	11.3	Double remote	L69481211
	4-way, 3-position, center exhaust	11.3	Double remote	L69481221
	4-way, 3-position, pressure center	11.3	Double remote	L69481231

1" Valve Subbase

		Cv	Port	Subbase (side ports)
Subbase		11.3	1"	K022095

Lubricated Non-Lubricated Service
2-position, Plug-In, 3/8" & 1" Basic Size

L 67 5 3 9 10 2 53

Type	
Double	65
Single	67

Operator	
Remote	4
Solenoid	5

Size	
3/8" Basic	3
1" Basic	8

Operator options	
Solenoid (basic) or remote	1
Solenoid with locking override	3
Solenoid w/light (120VAC, 24VDC) & non-locking override	8
Solenoid w/light (120VAC, 24VDC) & locking override	9

	Voltage & frequency		
	60Hz	50Hz	DC
45			12
49			24
53	120	110	
57	240	220	
Blank	Remote		

Duty Cycle	
2	Standard service, solenoid or remote
4	Continuous service solenoid

Enclosure "Class"	
10	Standard (NEMA 1 & 12) or remote

D
 Subbase & Manual Valves
 H Series Micro
 Modutefx Series
 H Series ISO
 Fieldbus Systems
 DX ISOMAX Series
 Valvair II Series

Lubricated or Non-Lubricated Service
3-position, Plug-In, 3/8" & 1" Basic Size

L 66 5 3 9 21 1 53

Type	
Double	66

Operator	
Remote	4
Solenoid	5

Size	
3/8" Basic	3
1" Basic	8

Operator options	
Solenoid (basic) or remote	1
Solenoid with locking override	3
Solenoid w/light (120VAC, 24VDC) & non-locking override	8
Solenoid w/light (120VAC, 24VDC) & locking override	9

	Voltage & frequency		
	60Hz	50Hz	DC
45			12
49			24
53	120	110	
57	240	220	
Blank	Remote		

Duty cycle	
1	Standard service, solenoid or remote
5	Continuous service solenoid

Enclosure "class"	
21	All ports blocked in neutral (NEMA 1 & 12 enclosure) or remote
22	Cyl. Ports open to exhaust in neutral (NEMA 1 & 12 enclosure) or remote
23	Cyl. Ports open to inlet in neutral (NEMA 1 & 12 enclosure) or remote

Most popular.



For inventory, lead times, and kit lookup, visit www.pdnplu.com

D252

Parker Hannifin Corporation
 Pneumatic Division
 Richland, Michigan
www.parker.com/pneumatics

Lubricated or Non-Lubricated Service
2-position, Direct Pipe Ported, 3/8" & 1" Basic Size

L 70 5 3 9 10 2 53 —

Type	
Double	68
Single	70

Operator	
Remote	4
Solenoid	5

Size	
3/8" NPT inlet & cylinder 1/2" NPT exhaust	3
1/2" NPT inlet, cylinder & exhaust	4
1" NPT inlet & cylinder 1-1/4" NPT exhaust	8
1-1/4" NPT inlet cylinder & exhaust	9*

* Not available operator option 4 - Remote pilot.

Lead length	
Blank	19" (Standard)

Voltage & frequency			
	60Hz	50Hz	DC
45			12
49			24
53	120	110	
57	240	220	
Blank	Remote		

Duty cycle	
2	Standard service, solenoid or remote
4	Continuous service solenoid

Enclosure "Class"	
10	Standard (NEMA 1 & 12) or remote
60*†	Hazardous duty (NEMA 7 & 9)
80†	NEMA 4

* Voltage 49 / 53 only.
 † Use with operator options 1 & 3 only, voltage 53 only.

Operator options	
Solenoid (basic) or remote	1
Solenoid with locking override	3
Solenoid w/ junction box & locking override	6
Solenoid w/ junction box & light (120VAC, 24VDC) & non-locking override	8
Solenoid w/ junction box & light (120VAC, 24VDC) & locking override	9

Lubricated or Non-Lubricated Service
3-position, Direct Pipe Ported, 3/8" & 1" Basic Size

L 69 5 3 9 21 1 53 —

Type	
Double	69

Operator	
Remote	4
Solenoid	5

Size	
3/8" NPT inlet & cylinder 1/2" NPT exhaust	3
1/2" NPT inlet, cylinder & exhaust	4
1" NPT inlet & cylinder 1-1/4" NPT exhaust	8
1-1/4" NPT inlet cylinder & exhaust	9*

* Not available operator option 4 - Remote pilot.

Lead length	
Blank	19" (Standard)

Voltage & frequency			
	60Hz	50Hz	DC
45			12
49			24
53	120	110	
57	240	220	
Blank	Remote		

Duty cycle	
1	Standard service, solenoid or remote
5	Continuous service solenoid

Enclosure "Class"	
All ports blocked in neutral	
21	Standard (NEMA 1 & 12) or remote
71*†	Hazardous duty (NEMA 7 & 9)
91†	NEMA 4
Cylinder ports open to exhaust in neutral	
22	Standard (NEMA 1 & 12) or remote
72*†	Hazardous duty (NEMA 7 & 9)
92†	NEMA 4
Cylinder ports open to inlet in neutral	
23	Standard (NEMA 1 & 12) or remote
73*†	Hazardous duty (NEMA 7 & 9)
93†	NEMA 4

* Voltage 49 / 53 only.
 † Use with operator options 1, 2 & 3 only, voltage 53 only.

 Most popular.



For inventory, lead time, and kit lookup, visit www.pdnplu.com

D253

Parker Hannifin Corporation
 Pneumatic Division
 Richland, Michigan
www.parker.com/pneumatics

D

Subbase & Manual Valves

H Series Micro

Moduflex Series

H Series ISO

Fieldbus Systems

DX ISOMAX Series

Valvair II Series

Modular Pneumatic Controls Plug-In Sandwich Block Design for Modular Port Regulation

These modular regulators assemble to any 3/8" basic valve interface pattern.

Port Regulation Made Easy

Place the sandwich on the manifold or subbase, tighten the four securing screws, then plug the valve into the sandwich and tighten its securing screws to complete the assembly.

Within minutes, these modular components can be installed in new, or used to improve existing manifold systems, without disturbing wiring or air connections.

3-Configurations

1. **Common Port Regulation** - A common regulated pressure is selected to both cylinder ports.
2. **Single Port Regulation** - Line pressure is available to one cylinder port, while a single regulated pressure is selected to the other cylinder port.
3. **Independent Port Regulation** - Two independently regulated pressures selected to the cylinder ports.

NOTE: When using single or independent port sandwich regulators, be aware that:

1. Cylinder port outlets are reversed.
2. 3-Position, cylinder ports open to exhaust and cylinder ports open to inlet functions are reversed. To produce a cylinder ports open to exhaust function, order valve with cylinder ports open to inlet. To produce a cylinder ports open to inlet function, order valve with cylinder ports open to exhaust.

Manual or Remote secondary pressure adjustment.

Three Pressure Ranges are standard for manual units:

- 1-30 PSIG
- 1-60 PSIG
- 2-125 PSIG

Range for Remote: 0-140 PSIG

Gauges are furnished standard; liquid filled gauges are optional.



Solenoid Valve Assembly

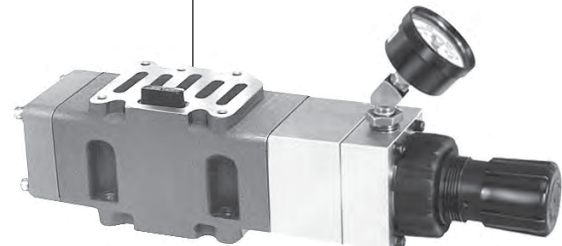

Regulator Assembly



Manifold

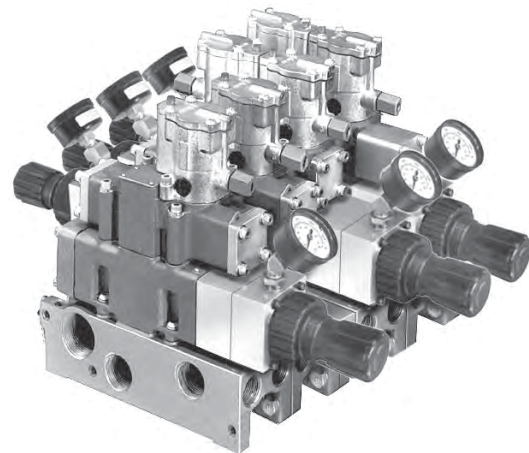

Typical Assembly

D
Subbase & Manual Valves
H Series Micro
Modutflex Series
H Series ISO
Fieldbus Systems
DX ISOMAX Series
Valvair II Series



For inventory, lead times, and kit lookup, visit www.pdnplu.com

Function - Single Port Regulation

This modular air pressure regulator assembly, when installed between a 3/8" basic, 4-Way valve and subbase or modular manifold, supplies one or more regulated pressures to one of the valve cylinder ports and supply pressure to the other cylinder port.

On Single Port Cylinder Port Regulation Units controlled by a single solenoid valve, cylinder port "B" is the normally open cylinder port. The solenoid is energized to open cylinder Port "A". On double solenoid operated valves, energizing solenoid "B" opens cylinder port "A" and energizing solenoid "A" opens cylinder port "B".

Valve must be converted to external pilot supply.

Features

Regulated pressure output from the valve is adjusted by knob on the manually set model or by air pressure signal applied to the regulator pilot port on the remotely set model.

For reduced pressure at "A" cylinder port, the regulator is mounted per assembly "A" on end opposite the electrical junction box. For reduced pressure at "B" cylinder port the regulator is mounted per Assembly "B" which places the regulator over the electrical junction box.

Furnished with pressure gauge as standard.

Pressure Range Options

Maximum Supply Pressure	140 PSIG
Output Pressure Range	1 - 30 PSIG
	1 - 60 PSIG
	2 - 125 PSIG

Operating Temperature Range

32°F (0°C) to 175°F (79°C)

How To Order

1. Select type of adjustment.
2. Select pressure range.
3. Select assembly style.

Example: Manual adjustment.
5-60 PSIG, Port A reduced.

Model No. L55405307C

Relief and Flow Characteristics

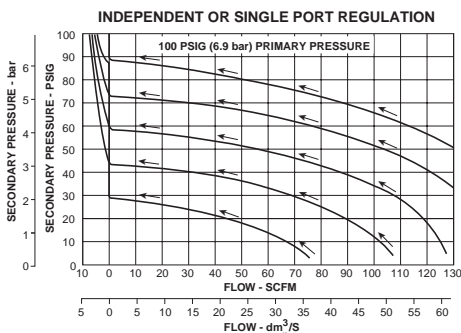

The above curves illustrate flow characteristics through an assembled valve, air regulator, and base (or modular manifold) unit.

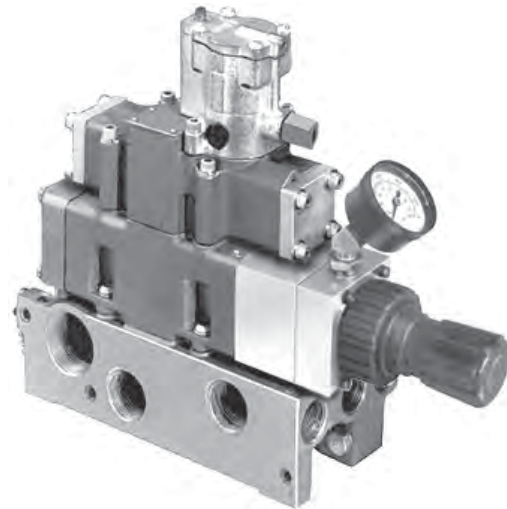

Assembly "A"

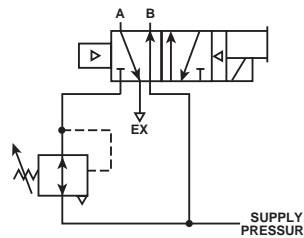

Supply Pressure at "B" & Regulated at "A"

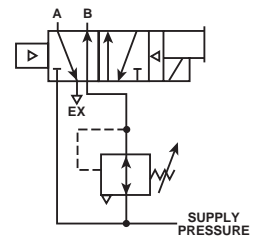

Supply Pressure at "A" & Regulated at "B"

Pressure adjustment	Pressure range PSIG	Model number	
		Reduced pressure Cyl. Port "A"	Cyl. Port "B"
Manual	1 - 60	L55405307C	L55407305C
	2 - 125	L55406307C	L55407306C
Remote	0 - 140	L55414307C	L55407314C

Note: When using single or independent port sandwich regulators, be aware that:

1. Cylinder port outlets are reversed.
2. 3-Position, cylinder ports open to exhaust and cylinder ports open to inlet functions are reversed. To produce a cylinder ports open to exhaust function, order valve with cylinder ports open to inlet. To produce a cylinder ports open to inlet function, order valve with cylinder ports open to exhaust.

See parts and accessories for gauges.



For inventory, lead times, and kit lookup, visit www.pdnplu.com

D
 Subbase & Manual Valves
 H Series Micro
 Moduteflex Series
 H Series ISO
 Fieldbus Systems
 DX ISOMAX Series
 Valvair II Series

Function - Independent Port Regulation

This modular air pressure regulation assembly, when installed between a 3/8" basic, 4-Way valve and subbase or modular manifold, supplies one or more regulated pressures to each of the valve cylinder ports.

Regulated pressure to cylinder port "A", and a second regulated pressure to cylinder port "B"; independently adjustable.

On Independent Cylinder Port Regulation Units controlled by a single solenoid valve, cylinder port "B" is the normally open cylinder port. The solenoid is energized to open cylinder port "A". On double solenoid operated valves, energizing solenoid "B" opens cylinder port "A" and energizing solenoid "A" opens cylinder port "B"

Valve must be converted to external pilot supply.

Features

Regulated pressure output from the valve is adjusted by knob on the manually set model or by air pressure signal applied to the regulator pilot port on the remotely set model.

Furnished with pressure gauge as standard.

The regulator controlling pressure to port "A" is mounted on the end opposite the electrical junction box (Assembly "A"). Regulated pressure from cylinder port "B" is controlled by the regulator installed over the electrical junction box (Assembly "B").

Pressure Range Options

Maximum Supply Pressure 140 PSIG
Output Pressure Range 1 - 60 PSIG
2 - 125 PSIG

Operating Temperature Range

32°F (0°C) to 175°F (79°C)

How To Order

1. Select type of adjustment.
2. Select pressure range.
3. Select assembly style.

Example: Manual adjustment.
5-60 PSIG range for cylinder port "A"
and 10-125 PSIG for cylinder port "B".

Model No. L55406305C

Relief and Flow Characteristics

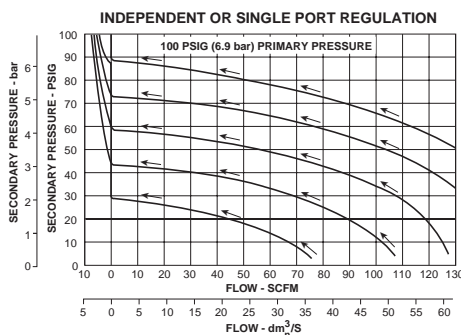

The above curves illustrate flow characteristics through an assembled valve, air regulator, and base (or modular manifold) unit.

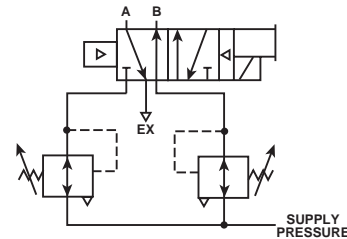
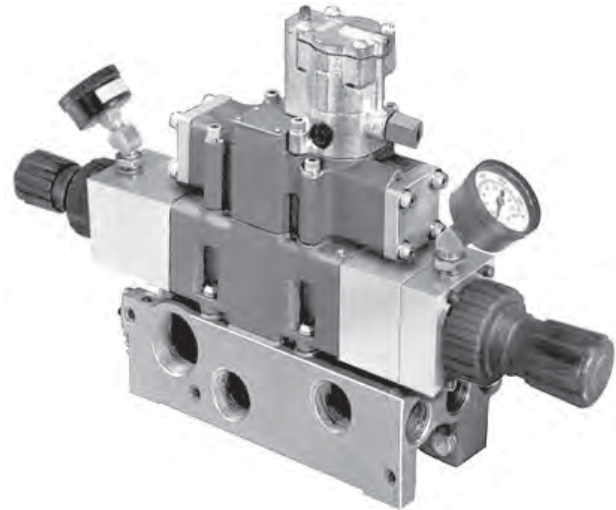

Independently Regulated Pressure at Both "A" & "B"

Pressure adjustment	Cylinder port "A" PSIG	Model number	
		Cylinder port "B"	
Manual	1 - 60	L55405305C	—
Remote	0 - 140	—	L55414314C†

† Remote operator units 0-140 PSIG

NOTE: When using single or independent port sandwich regulators, be aware that:

1. Cylinder port outlets are reversed.
2. 3-Position, cylinder ports open to exhaust and cylinder ports open to inlet functions are reversed. To produce a cylinder ports open to exhaust function, order valve with cylinder ports open to inlet. To produce a cylinder ports open to inlet function, order valve with cylinder ports open to exhaust.



For inventory, lead time, and kit lookup, visit www.pdnplu.com

D257

Parker Hannifin Corporation
Pneumatic Division
Richland, Michigan
www.parker.com/pneumatics

D

Subbase & Manual Valves

H Series Micro

Moduflex Series

H Series ISO

Fieldbus Systems

DX ISOMAX Series

Valvair II Series

Manual Adjusting

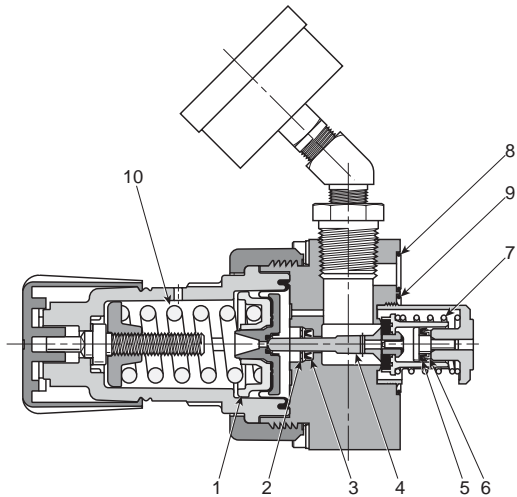

Remote Operated

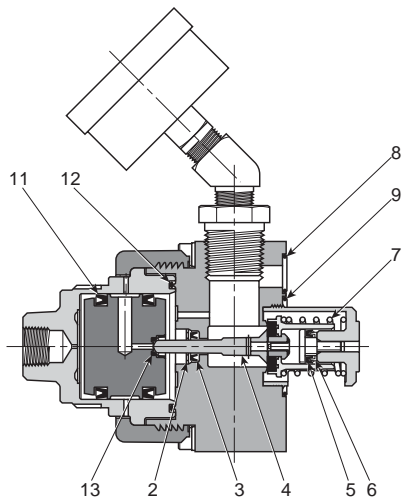

Replacement Parts

Item no.	Part number	Description
1	○	Diaphragm Assembly
2	○ ●	Retaining Ring
3	○ ●	Vee Packing
4	○ ●	Poppet Assembly
5	○ ●	Vee Packing
6	○ ●	Backflow Retainer
7	○ ●	Poppet Spring
8	○ ●	.989 ID x .070 W O-Ring
9	○ ●	1.301 ID x .070 W O-Ring
	P01698	1-30 PSI Spring
10	P04062	1-60 PSI Spring (Blue)
	P04063	2-125 PSI Spring
11	●	Vee Packing
12	●	1.674 ID x .103 W O-Ring
13	●	Vent Seal

○ Parts included in K352409 service kit for manual operated modular regulators.

● Parts included in K352411 service kit for remote operated modular regulators.

Replacement Gauges

PSIG	Standard
0-60	K4520N14060
0-160	K4520N14160
0-300	K4520N14300

Suggested Schematic of Assembled Valve, Air Regulation and Modular Manifold Units

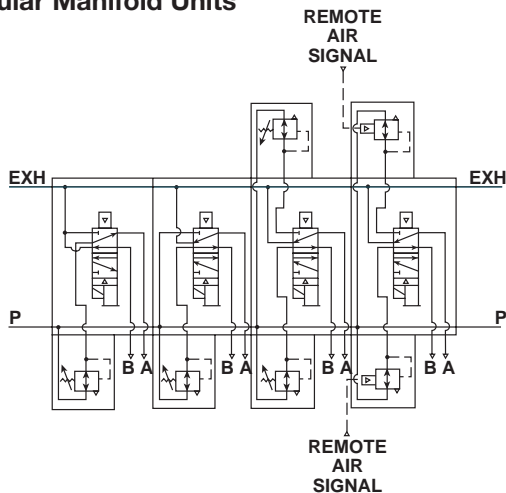

D
 Subbase & Manual Valves
 H Series Micro
 Modulflex Series
 H Series ISO
 Fieldbus Systems
 DX ISOMAX Series
 Valvair II Series



For inventory, lead times, and kit lookup, visit www.pdnplu.com

Common Port Regulation

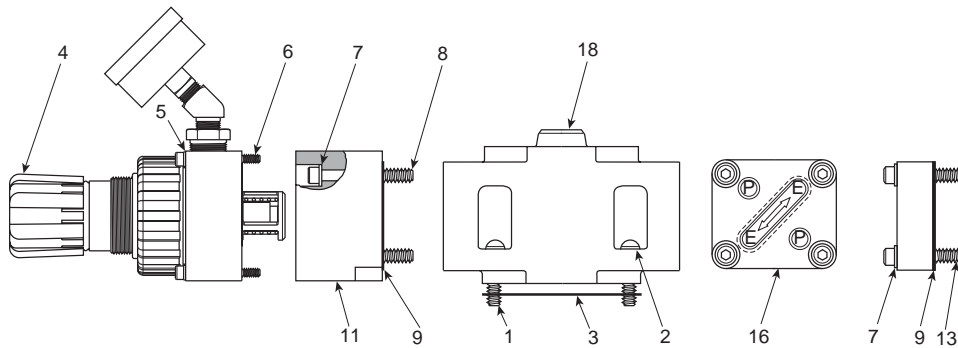

Single Port Regulation

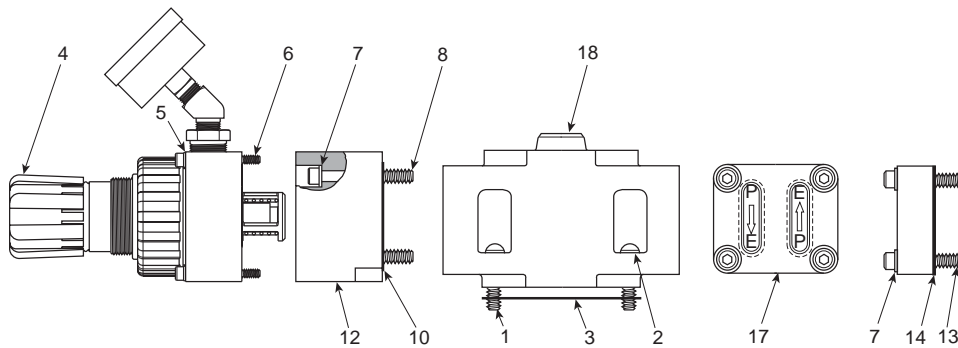

Independent Port Regulation

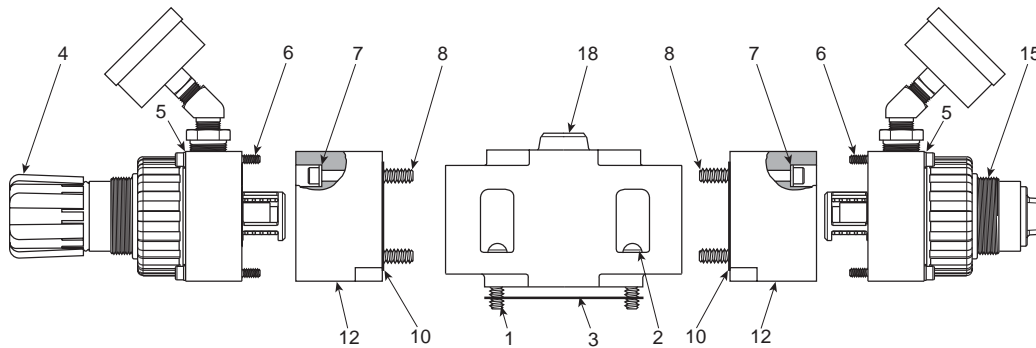

Table "E": Parts

Item No.	Part number	Description
1	H09815	Screw (4)
2	H17512	Lockwasher (4)
3	K183077	Gasket
4	Standard	Manual Reg. Assy. (w/Gauge)
	K472001C	1-30 PSIG
	K472002C	1-60 PSIG
5	K472003C	2-125 PSIG
	H17509	#10 Lockwasher
6	H10032	#10-32 x 1.75" Lg. SHCS
7	H17511	1/4" Lockwasher
8	H10069	1/4-20 x 2.25" Lg. SHCS

Item No.	Part number	Description
9	K183082	Gasket
10	K183084	Gasket
11	K043012	Function Block (P to P)
12	K043011	Function Block (P to E)
13	H100107	1/4-20 x 1-1/2" Lg. SHCS
14	K183083	Gasket
15	Standard	Remote Reg. Assy. (w/Gauge)
	K472009C	0-140 PSIG
16	K362308	Function Plate Assy. (Incl. 7, 9, 13)
17	K362307	Function Plate Assy. (Incl. 7, 13, 14)
18	K032270	Body Assy. (Incl. 1, 2, 3)



For inventory, lead time, and kit lookup, visit www.pdnplu.com

D259

Parker Hannifin Corporation
Pneumatic Division
Richland, Michigan
www.parker.com/pneumatics

D

Subbase & Manual Valves

H Series Micro

Modulflex Series

H Series ISO

Fieldbus Systems

DX ISOMAX Series

Valvair II Series

Service Kits

To use this chart you must know the basic valve series, quantity, and type of operators, or the first three characters of the valve model number.

Basic valve	Series (prefix)	Solenoid operated *				Remote pilot operated	
		Standard service (intermittent duty)		Special service ** (continuous duty)		Single	Double 2 & 3-position
Size		Single	Double 2 & 3-position	Single	Double 2 & 3-position	Single	Double 2 & 3-position
3/8"	L65	—	K352126	—	K352127	—	K352355
	L66	—	K352126	—	K352127	—	K352355
	L67	K352124	—	K352125	—	K352362	—
	L68	—	K352126	—	K352127	—	K352355
	L69	—	K352126	—	K352127	—	K352355
	L70	K352124	—	K352125	—	K352362	—
	L65	—	K352130	—	K352131	—	K352360
1"	L66	—	K352130	—	K352131	—	K352360
	L67	K352128	—	K352129	—	K352359	—
	L68	—	K352130	—	K352131	—	K352360
	L69	—	K352130	—	K352131	—	K352360
	L70	K352128	—	K352129	—	K352359	—

Notes:

* Kits for solenoid operated valves include solenoid service kits.

** Special service (continuous duty) solenoids may be identified as having gold colored solenoid tops.

Blank Plate Kit - 3/8" Basic

Manifold assembly	Port size	Part number
K142230	3/8"	K06020003
K142231	1/2"	
K142270	3/4"	

Kit includes: Blank plate, gasket, mounting screws.

Conversion Kits: Lubricated to Non-Lubricated Operation

Basic size	Operators (solenoid or remote pilot)	
	Single	Double (2-position)
3/8"	K322012	K322013

Flush Type Hex Drive Pipe Plugs for Port Isolation

Size (NPTF)	Part number
1/8"	K21R02012L
1/4"	K21R02025L
3/8"	K21R02037L
1/2"	K21R02050L
3/4"	K21R02075L

Interchangeable Manual Override Assemblies for Solenoid Operators



Non-locking type	Locking type
K162001	K152003

To override valve, use a flat head screwdriver to press in and rotate plunger 90° until plunger locks in place. For proper valve operation, override should be in the out position.

Electrical Connectors Single or Double Solenoid Valves

Basic size	Valve body		Subbase / manifold	
	Single solenoid	Double solenoid	10" leads	72" leads
3/8"	H02723	H02722	H02713	H02789
1"				



For inventory, lead time, and kit lookup, visit www.pdnplu.com

Plug-In
 De-Energized

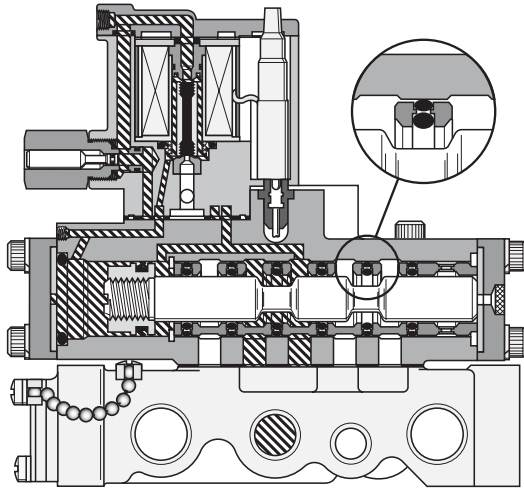

Direct Pipe Ported
 De-Energized

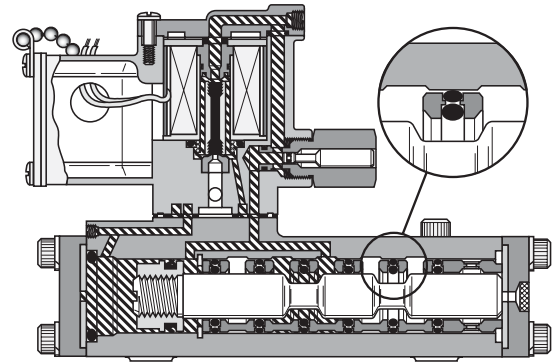

Energized

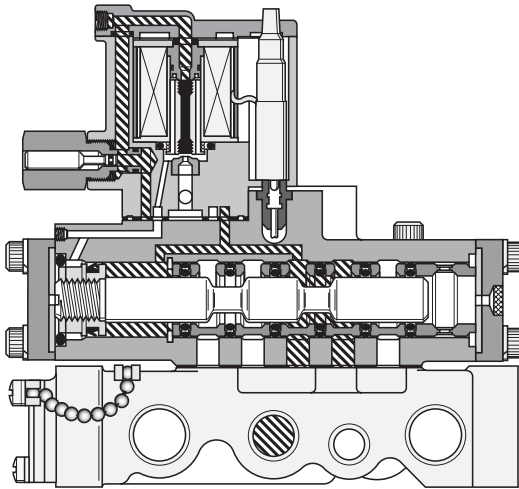

Energized

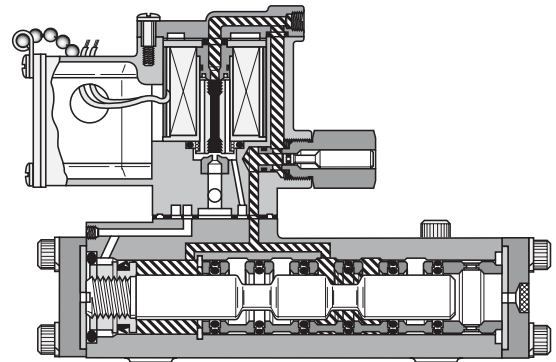

 **Pressure**  **Exhaust**

D	Subbase & Manual Valves
H Series Micro	Modulflex Series
H Series ISO	Fieldbus Systems
DX ISOMAX Series	Valvair II Series



For inventory, lead times, and kit lookup, visit www.pdnplu.com

D262

Parker Hannifin Corporation
 Pneumatic Division
 Richland, Michigan
www.parker.com/pneumatics

Flow Capacities

Valve Type	Cylinder Port Size (NPTF)	Mounting Style	Cv Flow Rating Inlet to Cylinder "A"
3/8" Single	3/8"	Direct Pipe	4.7
	1/2"	Direct Pipe	5.3
3/8" Double	3/8"	Direct Pipe	4.5
	1/2"	Direct Pipe	5.5
	3/4"	Subbase	5.0
	3/4"	Manifold	4.9
3/8" Double 3-Position	3/8"	Direct Pipe	4.1
	1/2"	Direct Pipe	4.5
	3/4"	Subbase	4.5
	3/4"	Manifold	4.1
1" Single & Double	1"	Direct Pipe	12.0
		Subbase	11.3

Recommended Filtration

Maintained 40 Micron Filtration

Life Expectancy

Valves designed for non-lubricated service as well as those designed for lubricated service will provide millions of maintenance free cycles. Under laboratory conditions service life exceeds 25,000,000 cycles.

Factory Pre-Lubrication

Valves are lubricated at assembly with Sunaplex 781 or equivalent. Valves specified for vacuum service are lubricated with Dow Corning Valve Seal A.

Valves for Non-Lubricated Service

3/8" basic valve sizes are designed to operate in applications where in-service lubrication is not desirable. Valves are factory pre-lubed as noted above. These valves may be used for lubricated service as well.

Lubrication

Air Line Lubricant (compatible with Nitrile & Polyurethane seals) must readily atomize and be of the medium aniline type. Aniline point range must be between 180° and 220°F. Viscosity @ 100°F: 140-170 SUS.

Recommended Lubricant

If in-service lubrication is required, use F442 oil, or equivalent. F442 is specially formulated to provide peak performance and maximum service life for air operated equipment.

Subbase & Manifold Valve Products Valvair II Series

Listing Agencies

General Purpose Approvals

CSA - Canadian Standards Association
 File Number 42024

Hazardous Duty Approvals

UL - Underwriters Laboratories, Inc.
 File Number E42542
 Category Y107

CSA - Canadian Standards Association
 File Number 24349

Solenoid Enclosure Ratings

Type	Listing agency	NEMA rating	Description
Plug-In	CSA	1 & 12	General purpose indoor only dust tight
Conduit / flying lead	CSA	1 & 12	General purpose indoor only dust tight
* Conduit (as specified)	UL & CSA	7 & 9	Hazardous location see chart below)
* Conduit (as specified)	CSA	4	General purpose indoor / outdoor

* See ordering information on specific valve type. (Direct Pipe Ported Valves Only.)

Hazardous Duty Solenoid Listing

Valves with solenoid operators designated for hazardous locations are UL & CSA Approved as follows:

National electric code	Ambient conditions	NEMA Classification
Class I Div. 1 Group C	Ethyl, Ether, Etc., Gases & Vapors	VII (7)
Class I Div. 1 Group D	Gasoline, Etc., Gases & Vapors	VII (7)
Class I Div. 2 Group B	Butadiene, Etc., Liquid, Fluid or Vapor Normally Contained, or Atmosphere Ventilated	VII (7)
Class II Div. 1 Group E	Metal Dust	IX (9)
Class II Div. 1 Group F	Coal, Coke, Carbon Black Dust	IX (9)
Class II Div. 1 Group G	Flour, Starch, Grain Dust	IX (9)

See Article 500 - Hazardous (Classified) Locations, National Electric Code.



For inventory, lead time, and kit lookup, visit www.pdnplu.com

Installation

Valves should be installed with reasonable accessibility for service. Exercise care in keeping piping lengths to a minimum. Piping should be free of dirt, chips & scale. Pipe joint compound should be used sparingly applied only to the thread, never to the valve body. Avoid undue strain at piping joints. Protect the valve from exposure to extreme temperatures, dirt and moisture to maximize life.

Note: Valves equipped with locking manual overrides. Override(s) must be in the fully extended position for proper valve operation.

Double Solenoid / Remote Caution

Note: It is recommended that double solenoid and double remote 2-Position valves be mounted with the main spool in the horizontal plane.

Wiring Instructions for Base Mounted Valves

Single Solenoid:

Use wires marked "2" & "3" for connection. Units with DC Solenoids and indicator lights are polarity sensitive. Wire marked "3" is positive (+).

Double Solenoid:

Use wires marked "1" & "2" for Solenoid "A". Use wires marked "3" & "4" for Solenoid "B". Units with DC Solenoids and indicator lights are polarity sensitive. Wires marked "1" and "3" are positive.

CAUTION:

DC Solenoids are polarity sensitive. Observe polarities indicated above.

Units with Flying Leads

Wires are not polarity sensitive.

CAUTION:

DC solenoids with indicator lights and / or arc suppression coils are polarity sensitive. Use red wire as positive.

"Special Service" Solenoid (Continuous Duty)

Special Service Solenoids are designed for use when the solenoid duty cycle is greater than 70% or when energization times are for 10 minutes or longer.

These solenoids should be used when valves are to be held energized for hours, days or weeks... or when extended ambient temperature operation is required. Apply the duty cycle formula to determine if this type of solenoid is required.

Duty Cycle Formula

$$\frac{\text{Time Energized}}{\text{Time Energized} + \text{Time Off}} \times 100 = \% \text{ Duty Cycle}$$

If Duty Cycle is 70% or greater, then Special Service (Continuous Duty) Solenoid should be used.

Pilot Supply Conversion

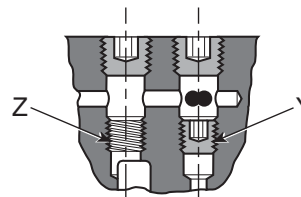

Base Mounted

For field conversion to external pilot supply, remove two 1/8" NPTF plugs from top of valve body and move bottom plug from "Y" to "Z".

Replace 1/8" NPTF plugs and connect pilot pressure to the 1/4" NPTF external pilot supply port "X" in subbase.

Direct Pipe Ported

For field conversion to external pilot supply, remove and discard 1/4" NPTF plug in external pilot supply port "X". Move stored plug "Y" to location "Z" in bottom of pilot supply port "X". Then connect pilot pressure to port "X" in valve body.

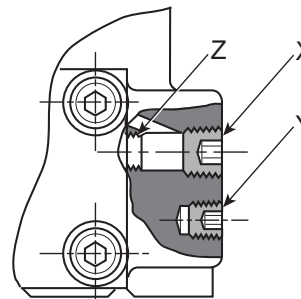

D	Subbase & Manual Valves
	H Series Micro
H Series	Modulflex Series
	ISO
Fieldbus Systems	DX ISOMAX Series
	Valvair II Series



For inventory, lead times, and kit lookup, visit www.pdnplu.com

* Assembly "A" places the regulator on the end opposite the electrical junction box. Assembly "B" places the regulator over the electrical junction box.

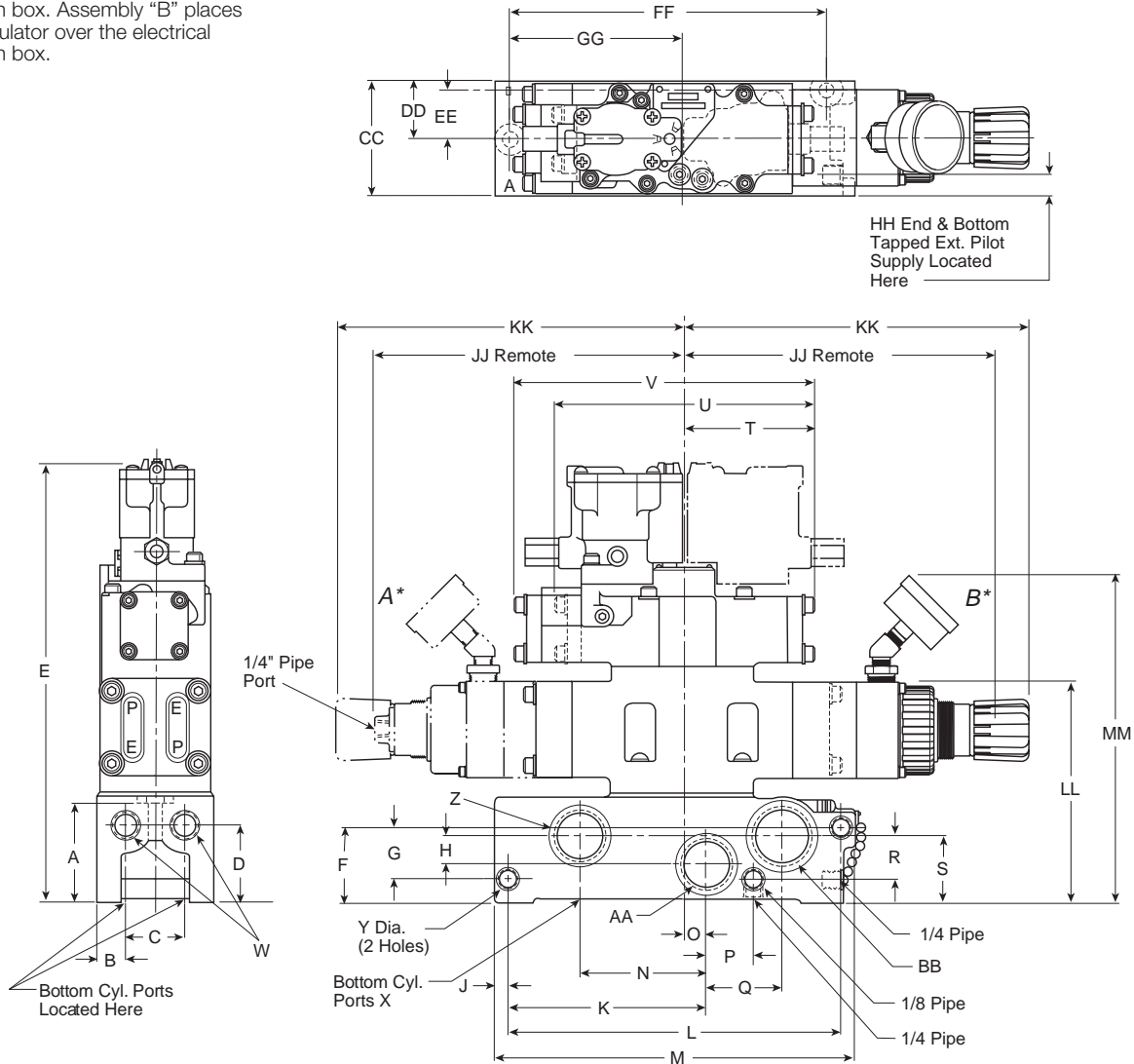

Dimensions - 3/8" Basic Valve

A	B	C	D	E	F	G	H	J	K	L	M	N	O
2.56 (65.0)	.75 (19.1)	1.50 (38.1)	2.09 (53.1)	11.28 (286.5)	2.06 (52.3)	1.41 (35.8)	.75 (19.1)	.34 (8.64)	5.00 (127.0)	8.44 (214.4)	9.09 (230.9)	3.19 (81.0)	.61 (15.5)
P	Q	R	S	T	U	V	W	X	Y	Z	AA	BB	CC
1.19 (30.2)	1.91 (48.5)	1.09 (27.7)	1.81 (46.0)	3.32 (84.3)	6.64 (168.7)	7.56 (192.0)	3/8", 1/2" or 3/4" NPTF	.39 (9.9)	1" NPTF	1" NPTF	1-1/4" NPTF	3.00 (76.2)	
DD	EE	FF	GG	HH	JJ	KK	LL	MM					
1.50 (38.1)	1.24 (31.5)	7.97 (202.4)	4.34 (110.2)	.40 (10.2)	8.53 (216.6)	10.15 (257.8)	5.46 (138.6)	8.80 (223.5)					

Inches (mm)



For inventory, lead time, and kit lookup, visit www.pdnplu.com

D265

Parker Hannifin Corporation
 Pneumatic Division
 Richland, Michigan
www.parker.com/pneumatics

D

Subbase & Manual
 Valves

H Series
 Micro

Moduflex
 Series

H Series
 ISO

Fieldbus
 Systems

DX ISOMAX
 Series

Valvair II
 Series

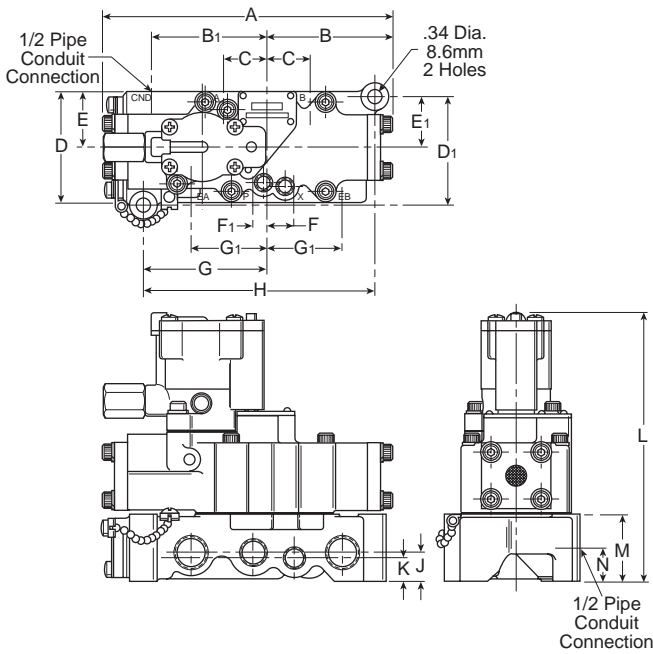

L6753 3/8" Dimensions, Single Solenoid

A	B	B ₁	C	D	D ₁	E	E ₁	F
7.56 (192)	3.32 (84.3)	2.94 (74.7)	1.12 (28.4)	2.88 (73.2)	2.84 (72.1)	1.44 (36.6)	1.34 (34)	.75 (19.1)
F ₁	G	G ₁	H	J	K	L	M	N
.38 (9.7)	3.16 (80.3)	2.00 (50.8)	6.03 (153.2)	.75 (19.1)	.62 (15.7)	6.93 (176)	1.75 (44.5)	1.00 (25.4)

Inches (mm)

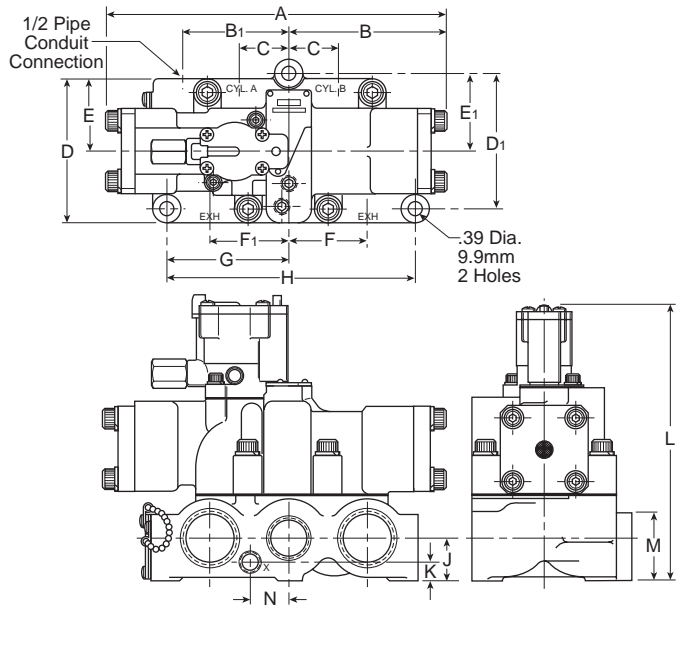

L6758 1" Dimensions, Single Solenoid

A	B	B ₁	C	D	D ₁	E	E ₁	F
10.46 (265.7)	4.75 (120.6)	2.94 (74.7)	3.38 (85.8)	4.56 (115.8)	4.28 (108.7)	2.28 (57.9)	2.44 (62)	2.45 (62.2)
F ₁	G	H	J	K	L	M	N	
2.46 (62.5)	3.81 (96.8)	7.62 (193.5)	1.31 (33.3)	.59 (15)	8.74 (222)	2.09 (53.1)	1.22 (31)	

Inches (mm)

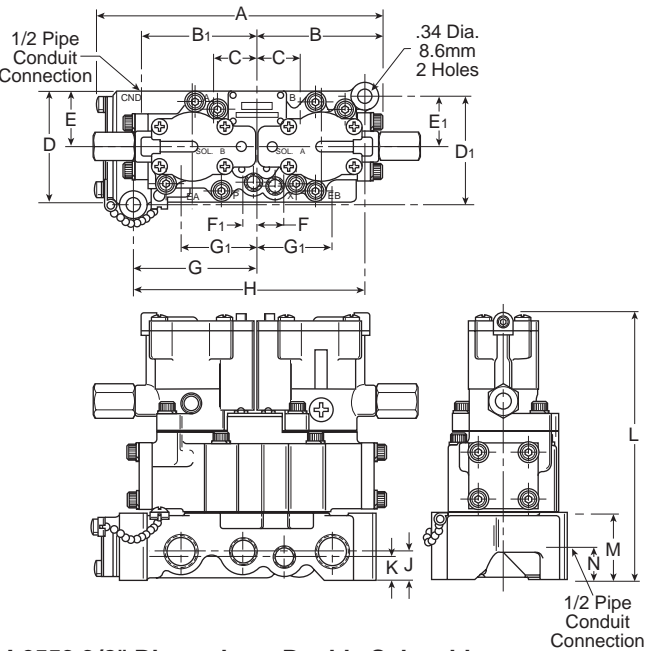

L6553 3/8" Dimensions, Double Solenoid

A	B	B ₁	C	D	D ₁	E	E ₁	F
7.38 (187.5)	3.32 (84.3)	2.94 (74.7)	1.12 (28.4)	2.88 (73.2)	2.84 (72.1)	1.44 (36.6)	1.34 (34)	.75 (19.1)
F ₁	G	G ₁	H	J	K	L	M	N
.38 (9.7)	3.16 (80.3)	2.00 (50.8)	6.03 (153.2)	.75 (19.1)	.62 (15.7)	6.93 (176)	1.75 (44.5)	1.00 (25.4)

Inches (mm)

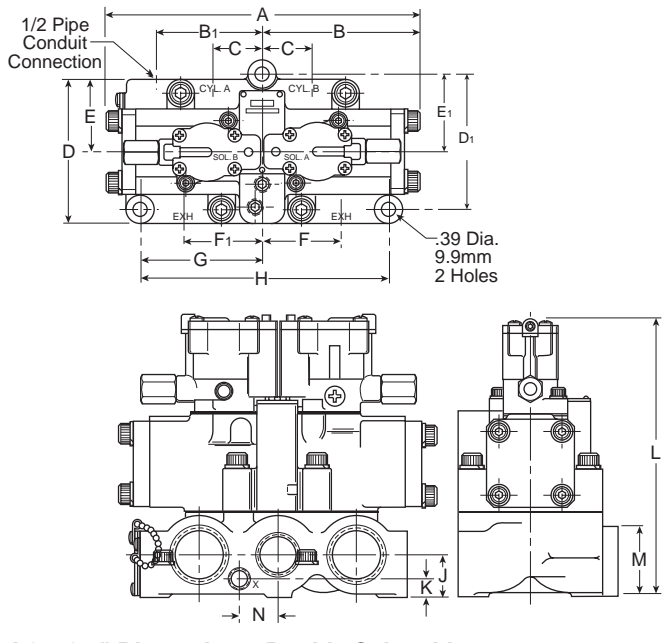

L6558 1" Dimensions, Double Solenoid

A	B	B ₁	C	D	D ₁	E	E ₁	F
9.50 (241.3)	4.75 (120.6)	3.38 (85.8)	1.53 (38.9)	4.56 (115.8)	4.28 (108.7)	2.28 (57.9)	2.44 (62)	2.45 (62.2)
F ₁	G	H	J	K	L	M	N	
2.46 (62.5)	3.81 (96.8)	7.62 (193.5)	1.31 (33.3)	.59 (15)	8.74 (222)	2.09 (53.1)	1.22 (31)	

Inches (mm)

D
 Subbase & Manual Valves
 H Series Micro
 Modutefx Series
 H Series ISO
 Fieldbus Systems
 DX ISOMAX Series
 Valvair II Series



For inventory, lead times, and kit lookup, visit www.pdnplu.com

D266

Parker Hannifin Corporation
 Pneumatic Division
 Richland, Michigan
www.parker.com/pneumatics

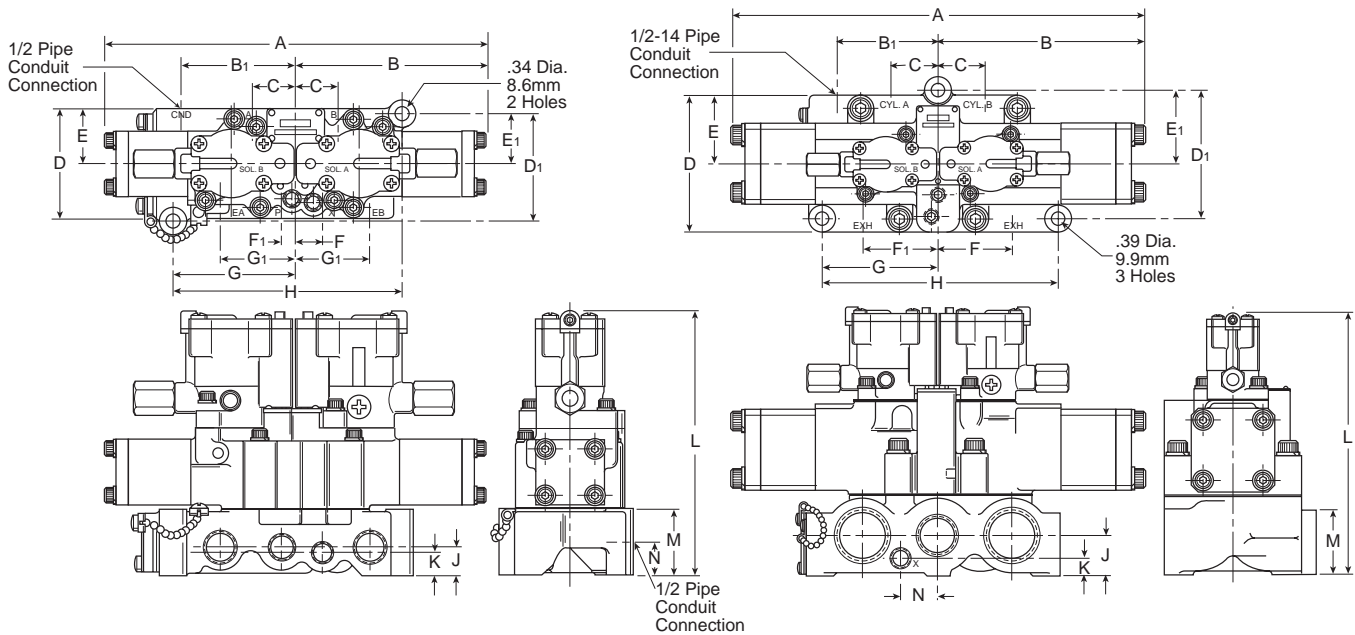

L6653 3/8" Dimensions, 3-Position, Double Solenoid

A	B	B ₁	C	D	D ₁	E	E ₁	F
9.64	4.82	2.94	1.12	2.88	2.84	1.44	1.34	.75
(244.8)	(122.4)	(74.7)	(28.4)	(73.2)	(72.1)	(36.6)	(34)	(19.1)
F ₁	G	G ₁	H	J	K	L	M	
.38	3.16	2.00	6.03	.75	.62	6.93	1.00	
(9.7)	(80.3)	(50.8)	(153.2)	(19.1)	(15.7)	176	(25.4)	

Inches (mm)

L6658 1" Dimensions, 3-Position, Double Solenoid

A	B	B ₁	C	D	D ₁	E	E ₁	F
13.62	6.81	3.38	1.53	4.56	4.28	2.28	2.44	2.45
(345.9)	(173)	(85.8)	(38.9)	(115.8)	(108.7)	(57.9)	(62)	(62.2)
F ₁	G	H	J	K	L	M	N	
2.46	3.81	7.62	1.31	.59	8.74	2.09	1.22	
(62.5)	(96.8)	(193.5)	(33.3)	(15)	(222)	(53.1)	(31)	

Inches (mm)

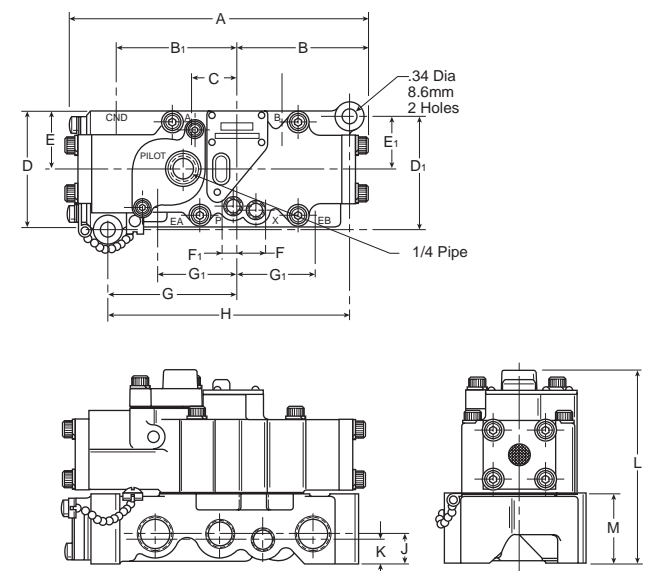

L6743 3/8" Dimensions, Single Remote Pilot

A	B	B ₁	C	D	D ₁	E	E ₁	F
7.56	3.32	2.94	1.12	2.88	2.84	1.44	1.34	.75
(192)	(84.3)	(74.7)	(28.4)	(73.2)	(72.1)	(36.6)	(34)	(19.1)
F ₁	G	G ₁	H	J	K	L	M	
.38	3.16	2.00	6.03	.75	.62	4.76	1.75	
(9.7)	(80.3)	(50.8)	(153.2)	(19.1)	(15.7)	(120.9)	(44.5)	

Inches (mm)

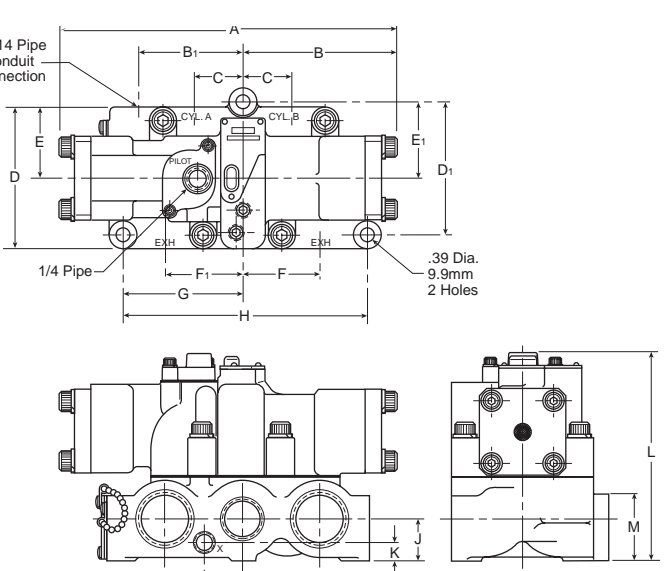

L6748 1" Dimensions, Single Remote Pilot

A	B	B ₁	C	D	D ₁	E	E ₁	F
10.46	4.75	3.38	1.53	4.56	4.28	2.28	2.44	2.45
(265.7)	(120.6)	(85.8)	(38.9)	(115.8)	(108.7)	(57.9)	(62)	(62.2)
F ₁	G	H	J	K	L	M	N	
2.46	3.81	7.62	1.31	.59	6.57	2.09	1.22	
(62.5)	(96.8)	(193.5)	(33.3)	(15)	(166.9)	(53.1)	(31)	

Inches (mm)



For inventory, lead time, and kit lookup, visit www.pdnplu.com

D267

Parker Hannifin Corporation
 Pneumatic Division
 Richland, Michigan
www.parker.com/pneumatics

D

Subbase & Manual Valves

H Series Micro

Moduflex Series

H Series ISO

Fieldbus Systems

DX ISOMAX Series

Valvair II Series

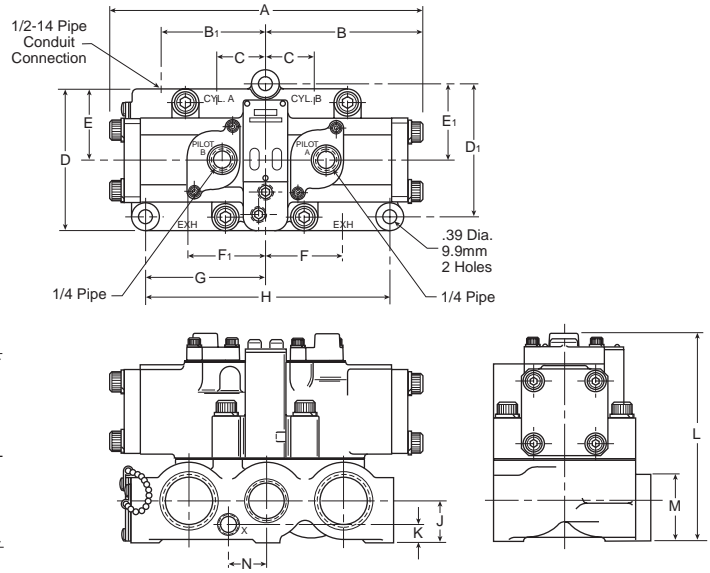
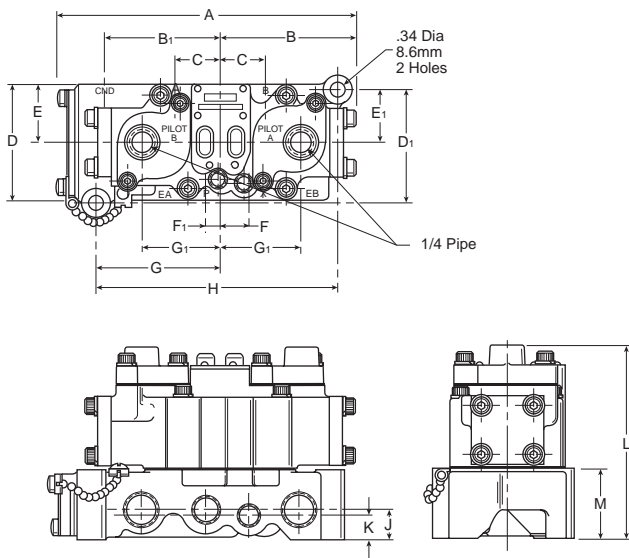

L6543 3/8" Dimensions, Double Remote Pilot

A	B	B ₁	C	D	D ₁	E	E ₁	F
7.56 (192)	3.32 (84.3)	2.94 (74.7)	1.12 (28.4)	2.88 (73.2)	2.84 (72.1)	1.44 (36.6)	1.34 (34)	.75 (19.1)
F ₁	G	G ₁	H	J	K	L	M	
.38 (9.7)	3.16 (80.3)	2.00 (50.8)	6.03 (153.2)	.75 (19.1)	.62 (15.7)	4.76 (120.9)	1.75 (44.5)	

Inches (mm)

L6548 1" Dimensions, Double Remote Pilot

A	B	B ₁	C	D	D ₁	E	E ₁	F
9.50 (241.3)	4.75 (120.6)	3.38 (85.8)	1.53 (38.9)	4.56 (115.8)	4.28 (108.7)	2.28 (57.9)	2.44 (62)	2.45 (62.2)
F ₁	G	H	J	K	L	M	N	
2.46 (62.5)	3.81 (96.8)	7.62 (193.5)	1.31 (33.3)	.59 (15)	6.57 (166.9)	2.09 (53.1)	1.22 (31)	

Inches (mm)

D
Subbase & Manual Valves
H Series Micro
Moduteflex Series
H Series ISO
Fieldbus Systems
DX ISOMAX Series
Valvair II Series

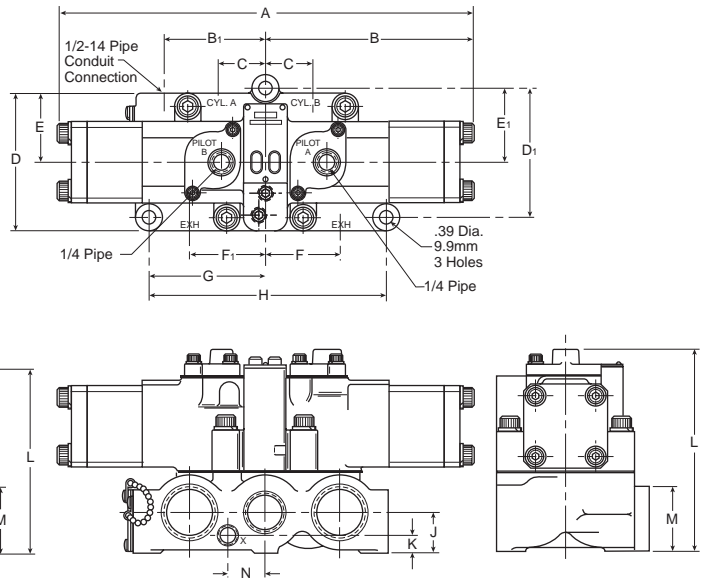
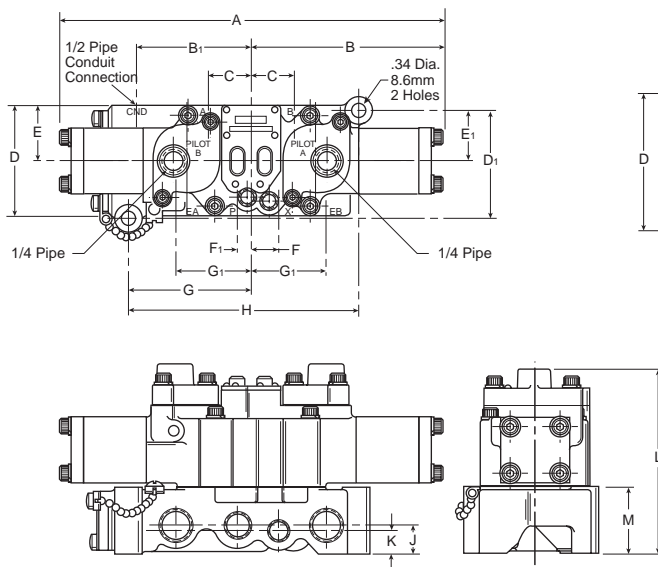

L6643 3/8" Dimensions, 3-Position, Remote Pilot

A	B	B ₁	C	D	D ₁	E	E ₁	F
9.64 (244.8)	4.82 (122.4)	2.94 (74.7)	1.12 (28.4)	2.88 (73.2)	2.84 (72.1)	1.44 (36.6)	1.34 (34)	.75 (19.1)
F ₁	G	G ₁	H	J	K	L	M	
.38 (9.7)	3.16 (80.3)	2.00 (50.8)	6.03 (153.2)	.75 (19.1)	.62 (15.7)	4.76 (120.9)	1.75 (44.5)	

Inches (mm)

L6648 1" Dimensions, 3-Position, Remote Pilot

A	B	B ₁	C	D	D ₁	E	E ₁	F
13.62 (345.9)	6.81 (173)	3.38 (85.8)	1.53 (38.9)	4.56 (115.8)	4.28 (108.7)	2.28 (57.9)	2.44 (62)	2.45 (62.2)
F ₁	G	H	J	K	L	M	N	
2.46 (62.5)	3.81 (96.8)	7.62 (193.5)	1.31 (33.3)	.59 (15)	6.57 (166.8)	2.09 (53.1)	1.22 (31)	

Inches (mm)



For inventory, lead times, and kit lookup, visit www.pdnplu.com

D268

Parker Hannifin Corporation
 Pneumatic Division
 Richland, Michigan
www.parker.com/pneumatics

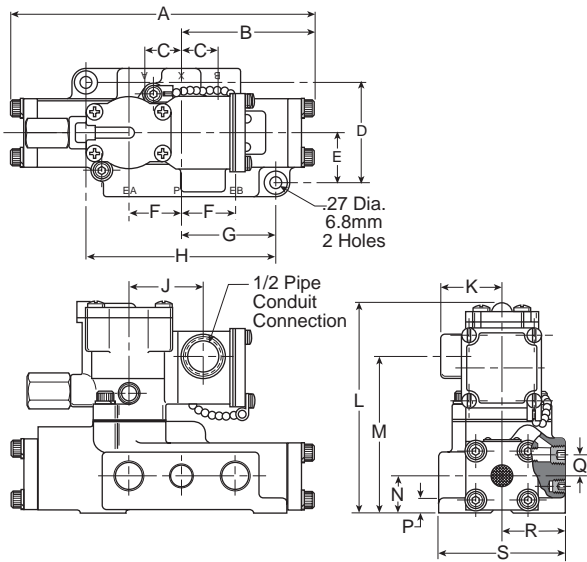

L705 3/8" Dimensions, Single Solenoid

A	B	C	D	E	F	G	H	J
7.56	3.32	.90	2.56	1.28	1.33	2.34	4.69	1.82
(192)	(84.3)	(22.9)	(65)	(32.5)	(33.8)	(59.4)	(119.1)	(46.2)
K	L	M	N	P	Q	R	S	
1.50	5.35	3.91	.94	.38	.53	1.62	3.25	
(38.1)	(135.9)	(99.3)	(23.9)	(9.7)	(13.5)	(41.1)	(82.6)	

Inches (mm)

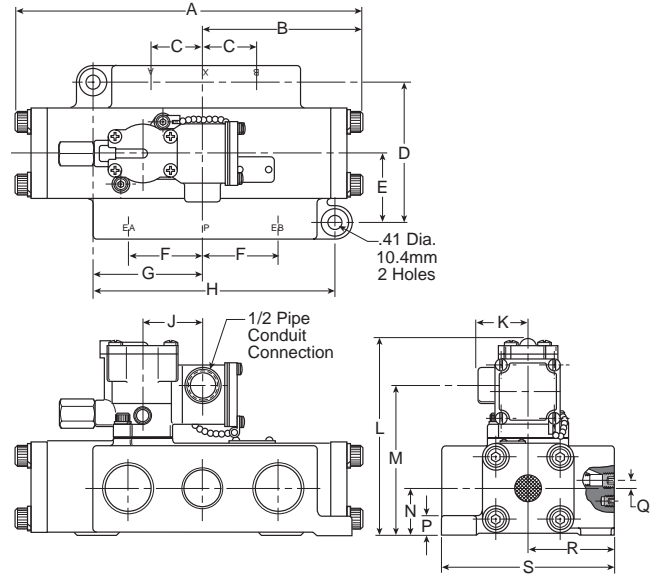

L705 1" Dimensions, Single Solenoid

A	B	C	D	E	F	G	H	J
10.46	4.75	1.62	4.25	2.12	2.19	3.44	7.44	1.82
(265.7)	(120.6)	(41.1)	(108)	(53.8)	(55.6)	(87.4)	(189)	(46.2)
K	L	M	N	P	Q	R	S	
1.50	6.44	4.95	1.50	.69	.20	2.62	5.25	
(38.1)	(163.6)	(125.7)	(38.1)	(17.5)	(5.1)	(66.5)	(133.4)	

Inches (mm)

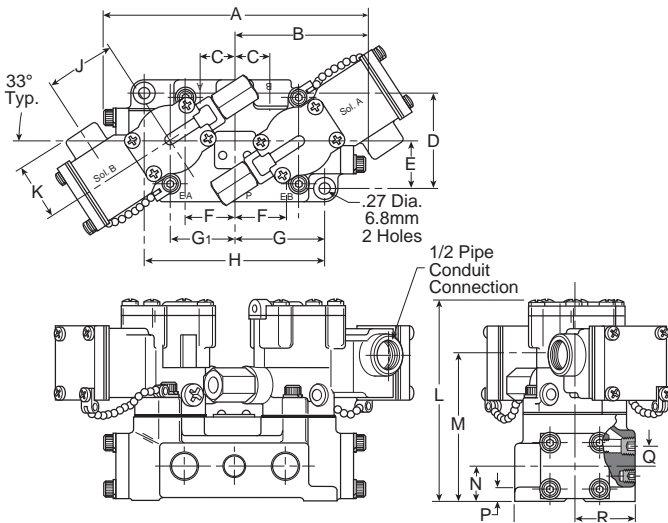

L685 3/8" Dimensions, Double Solenoid

A	B	C	D	E	F	G	G ₁	H
7.56	3.32	.90	2.56	1.28	1.33	2.34	1.66	4.69
(192)	(84.3)	(22.9)	(65)	(32.5)	(33.8)	(59.4)	(42.4)	(119.1)
J	K	L	M	N	P	Q	R	S
1.82	1.50	5.35	3.91	.94	.38	.53	1.62	3.25
(46.2)	(38.1)	(135.9)	(99.3)	(23.9)	(9.7)	(13.5)	(41.1)	(82.6)

Inches (mm)

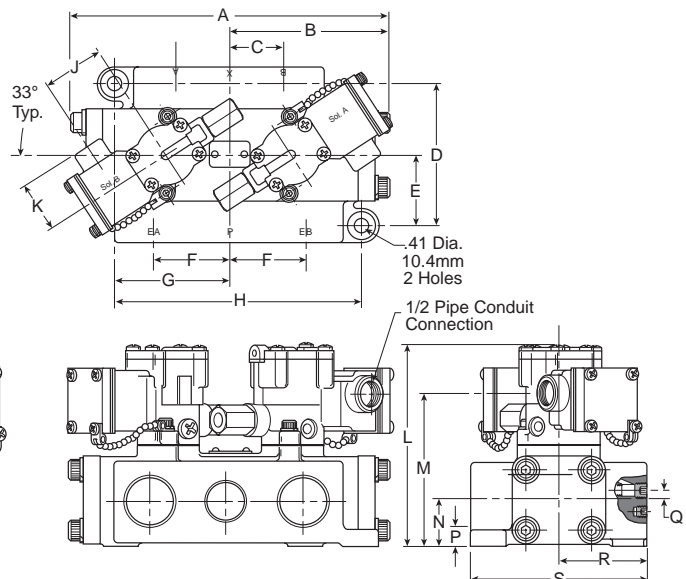

L685 1" Dimensions, Double Solenoid

A	B	C	D	E	F	G	H	J
9.50	4.75	1.62	4.25	2.12	2.19	3.44	7.44	1.82
(241.3)	(120.6)	(41.1)	(108)	(53.8)	(55.6)	(87.4)	(189)	(46.2)
K	L	M	N	P	Q	R	S	
1.50	6.44	4.95	1.50	.69	.20	2.62	5.25	
(38.1)	(163.6)	(125.7)	(38.1)	(17.5)	(5.1)	(66.5)	(133.4)	

Inches (mm)



For inventory, lead time, and kit lookup, visit www.pdnplu.com

D269

Parker Hannifin Corporation
 Pneumatic Division
 Richland, Michigan
www.parker.com/pneumatics

D

Subbase & Manual Valves

H Series Micro

Moduflex Series

H Series ISO

Fieldbus Systems

DX ISOMAX Series

Valvair II Series

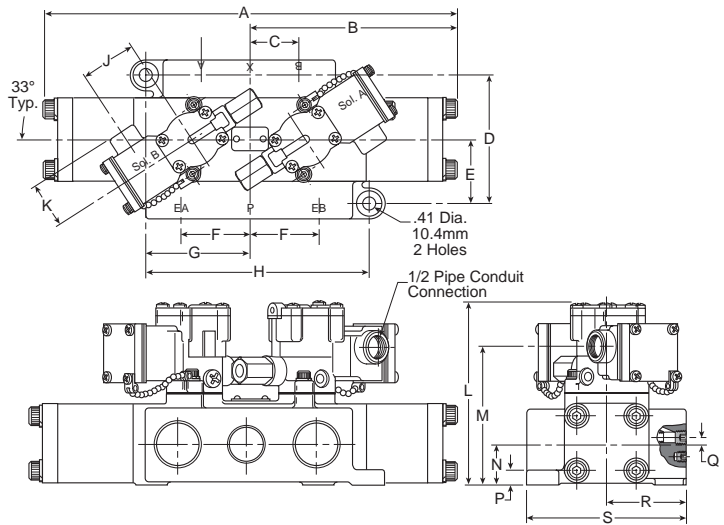
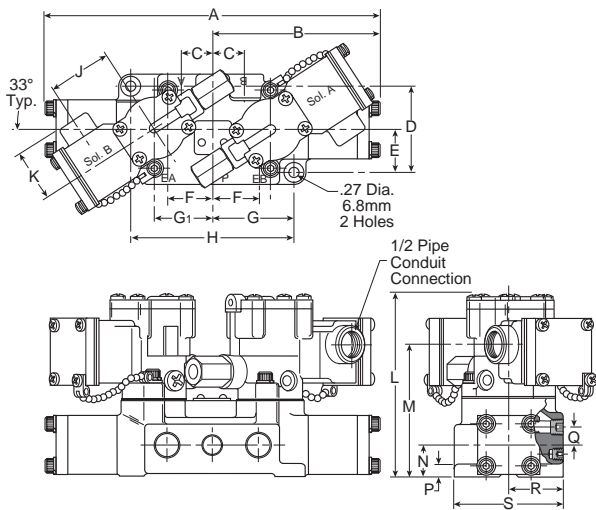

L695 3/8" Dimensions, 3-Position Double Solenoid

A	B	C	D	E	F	G	G ₁	H
9.64	4.82	.90	2.56	1.28	1.33	2.34	1.66	4.69
(244.8)	(122.4)	(22.9)	(65)	(32.5)	(33.8)	(59.4)	(42.4)	(119.1)
J	K	L	M	N	P	Q	R	S
1.82	1.50	5.35	3.91	.94	.38	.53	1.62	3.25
(46.2)	(38.1)	(135.9)	(99.3)	(23.9)	(9.7)	(13.5)	(41.1)	(82.6)

Inches (mm)

L695 1" Dimensions, 3-Position, Double Solenoid

A	B	C	D	E	F	G	H	J
13.63	6.81	1.62	4.25	2.12	2.19	3.44	7.44	1.82
(346.2)	(173)	(41.1)	(108)	(53.8)	(55.6)	(87.4)	(189)	(46.2)
K	L	M	N	P	Q	R	S	
1.50	6.44	4.95	1.50	.69	.20	2.62	5.25	
(38.1)	(163.6)	(125.7)	(38.1)	(17.5)	(5.1)	(66.5)	(133.4)	

Inches (mm)

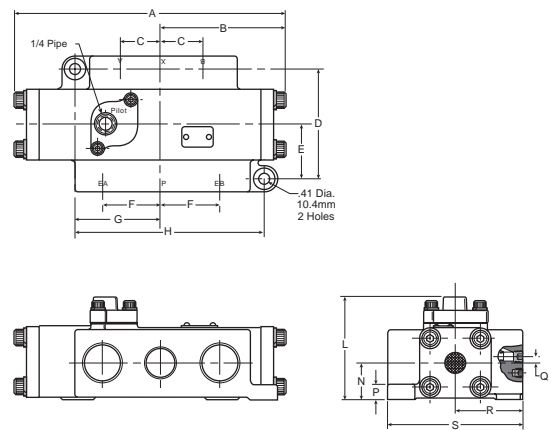
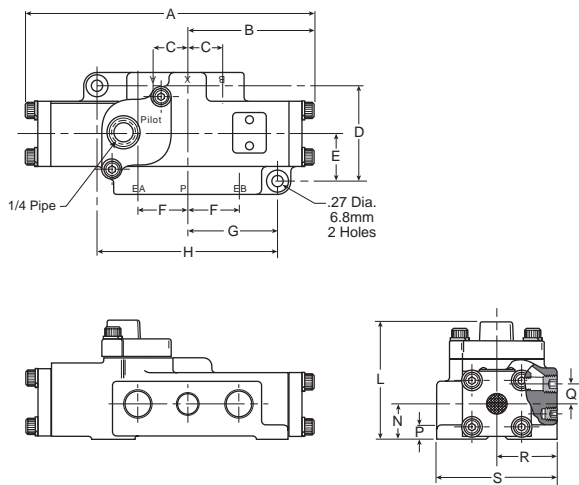

L704 3/8" Dimensions, Single Remote Pilot

A	B	C	D	E	F	G	H	L
7.56	3.32	.90	2.56	1.28	1.33	2.34	4.69	3.18
(192)	(84.3)	(22.9)	(65)	(32.5)	(33.8)	(59.4)	(119.1)	(80.8)
N	P	Q	R	S				
.94	.38	.53	1.62	3.25				
(23.9)	(9.7)	(13.5)	(41.1)	(82.6)				

Inches (mm)

L704 1" Dimensions, Single Remote Pilot

A	B	C	D	E	F	G	H	L
10.46	4.75	1.62	4.25	2.12	2.19	3.44	7.44	4.09
(265.7)	(120.6)	(41.1)	(108)	(53.8)	(55.6)	(87.4)	(189)	(103.9)
N	P	Q	R	S				
1.50	.69	.20	2.62	5.25				
(38.1)	(17.5)	(5.1)	(66.5)	(133.4)				

Inches (mm)

D
 Subbase & Manual Valves
 H Series Micro
 Moduteflex Series
 H Series ISO
 Fieldbus Systems
 DX ISOMAX Series
 Valvair II Series



For inventory, lead times, and kit lookup, visit www.pdnplu.com

D270

Parker Hannifin Corporation
 Pneumatic Division
 Richland, Michigan
www.parker.com/pneumatics

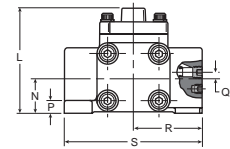
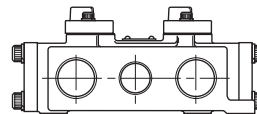
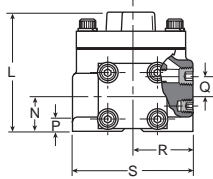
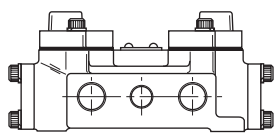
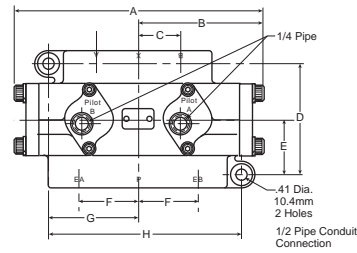
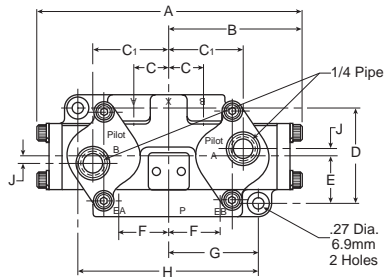

L684 3/8" Dimensions, Double Remote Pilot

A	B	C	C ₁	D	E	F	G	H
6.64	3.32	.90	1.98	2.56	1.28	1.33	2.34	4.69
(168.7)	(84.3)	(22.9)	(50.3)	(65)	(32.5)	(33.8)	(59.4)	(119.1)
J	L	N	P	Q	R	S		
.22	3.05	.94	.38	.53	1.62	3.25		
(5.6)	(77.5)	(23.9)	(9.7)	(13.5)	(41.1)	(82.6)		

Inches (mm)

L684 1" Dimensions, Double Remote Pilot

A	B	C	D	E	F	G	H	L
9.50	4.75	1.62	4.25	2.12	2.19	3.44	7.44	4.09
(241.3)	(120.6)	(41.1)	(108)	(53.8)	(55.6)	(87.4)	(189)	(103.9)
N	P	Q	R	S				
1.50	.69	.20	2.62	5.25				
(38.1)	(17.5)	(5.1)	(66.5)	(133.4)				

Inches (mm)

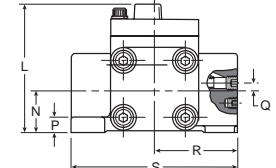
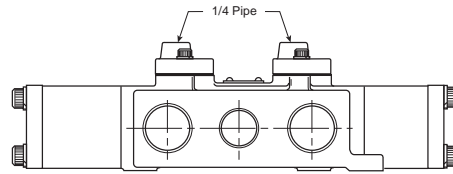
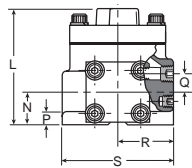
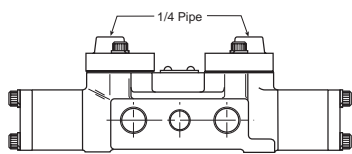
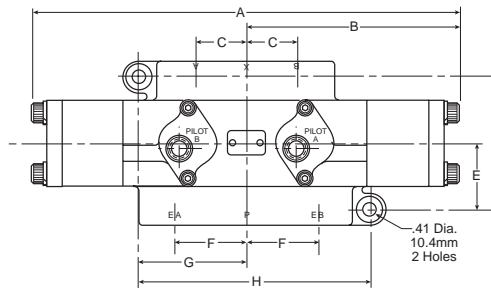
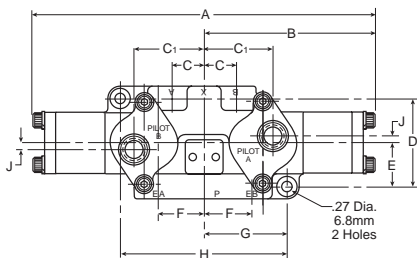

L694 3/8" Dimensions, 3-Position, Double Remote Pilot

A	B	C	C ₁	D	E	F	G	H
9.64	4.82	.90	1.98	2.56	1.28	1.33	2.34	4.69
(244.8)	(122.4)	(22.9)	(50.3)	(65)	(32.5)	(33.8)	(59.4)	(119.1)
J	L	N	P	Q	R	S		
.22	3.05	.94	.38	.53	1.62	3.25		
(5.6)	(77.5)	(23.9)	(9.7)	(13.5)	(41.1)	(82.6)		

Inches (mm)

L694 1" Dimensions, 3-Position, Double Remote Pilot

A	B	C	D	E	F	G	H	L
13.63	6.81	1.62	4.25	2.12	2.19	3.44	7.44	6.44
(346.2)	(173)	(41.1)	(108)	(53.8)	(55.6)	(87.4)	(189)	(163.6)
N	P	Q	R	S				
1.50	.69	.20	2.62	5.25				
(38.1)	(17.5)	(5.1)	(66.5)	(133.4)				

Inches (mm)



For inventory, lead time, and kit lookup, visit www.pdnplu.com

D271

Parker Hannifin Corporation
 Pneumatic Division
 Richland, Michigan
www.parker.com/pneumatics

D

Subbase & Manual Valves

H Series Micro

Moduflex Series

H Series ISO

Fieldbus Systems

DX ISOMAX Series

Valvair II Series

Plug-in Manifold, 3/8" Basic

- K142230Cylinder ports 3/8" NPTF
- K142231Cylinder ports 1/2" NPTF
- K142270Cylinder ports 3/4" NPTF
- Exhaust port..... 1" NPTF
- Inlet port..... 1" NPTF
- Conduit port..... 1-1/4" NPTF

Note: Manifold assemblies include mounting hardware.

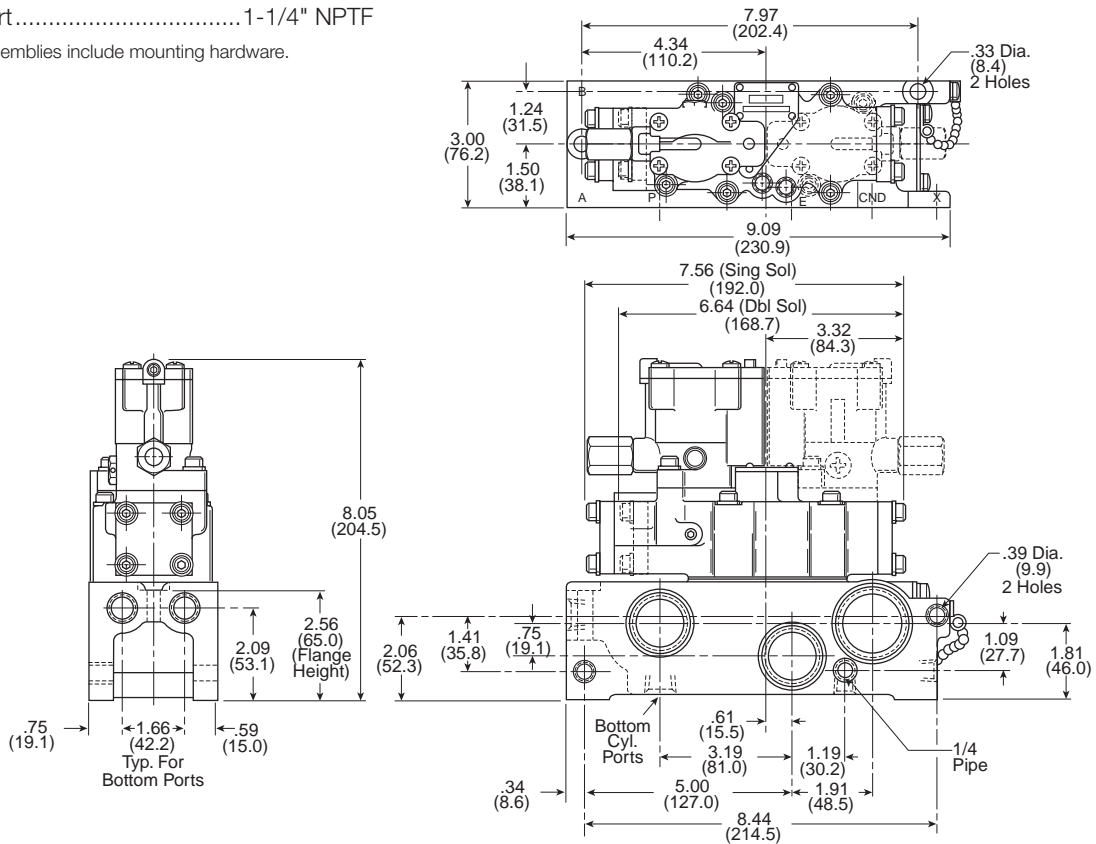

D	Subbase & Manual Valves
H Series Micro	Modulflex Series
H Series ISO	Fieldbus Systems
DX ISOMAX Series	Valvair II Series



For inventory, lead times, and kit lookup, visit www.pdnplu.com

D272

Parker Hannifin Corporation
 Pneumatic Division
 Richland, Michigan
www.parker.com/pneumatics



For inventory, lead time, and kit lookup, visit www.pdnplu.com

Parker Hannifin Corporation
Pneumatic Division
Richland, Michigan
www.parker.com/pneumatics

D

Subbase & Manual Valves

H Series Micro

Moduflex Series

H Series ISO

Fieldbus Systems

DX ISOMAX Series

Valvair II Series

Pneumatic Valve Products Manual / Mechanical Series

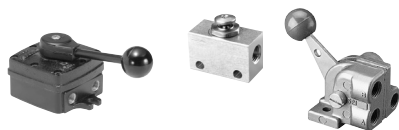
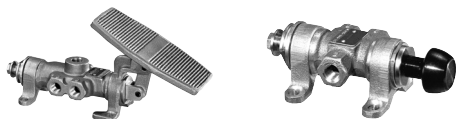

Directair 2 / Directair 4 Series

Features	E2
Common Part Numbers / Ordering Information	E3-E6
Technical Data	E7-E8
Dimensional Data	E9-E13

Viking Xtreme Lever Series

Features	E14
Common Part Numbers / Ordering Information	E15-E16
Accessories	E17
Dimensional Data	E17a-E20

42 Lever / Pedal Series

Features	E21
Common Part Numbers / Ordering Information	E22
Dimensional Data	E23

MO Series

Features	E24
Common Part Numbers / Ordering Information	E25-E27
Accessories	E28
Technical Data	E29-E35
Dimensional Data	E36-E51

Safety

Lockout Valves	E52-E59
Two Hand Control	E60-E61

Brass Poppet / Sliding Seal

PL / VL Series	E62-E63
HV Series	E64
Sliding Seal Valves	E65
Button Operated Valves	E66
Hand / Cam Operated Valves	E67
Bleed Valves	E68

Control Panel Products

Features	E69
Accessories	E70-E73
Technical / Dimensional Data	E74-E76

Sensing Products, Limit Switches

Features	E77
Technical / Dimensional Data	E81-E85

Features

Directair 2 & 4 Series

Directair 2, 1/8" valves
Poppet style – .17 Cv

- Economical
- 3-way normally closed function

Directair 2, 1/8" valves
Packed bore style – .20 Cv

- Stainless steel spool
- Fluorocarbon o-rings
- 3-way & 4-way

Directair 4, 1/4" valves
Packed bore style – .83 Cv

- Stainless steel spool
- Fluorocarbon o-rings
- 3-way & 4-way

Material specifications

Body and operator housings	Aluminum extrusion
Bushings and pilot piston	Brass
Dynamic seals	Fluorocarbon
Operator o-rings, u-cups	Buna (nitrile)
Poppet ball	Nylon
Spacers - Directair 2	Aluminum
Spacers - Directair 4	Zinc die cast
Spool	Stainless steel

Flow Rating (Cv)

Flow Path	Direct Pipe Spool, 1/8" Ports	Direct Pipe Poppet, 1/8" Ports
Directair 2		
1 → 2	.199	.125
1 → 4	.191	—
2 → 3	.192	.215
4 → 5	.212	—
Avg.	.199	N/A
Directair 4		
1 → 2	.82	.64
1 → 4	.84	.66
2 → 3	.84	.63
4 → 5	.83	.63
Avg.	.83	.64

 Most popular.

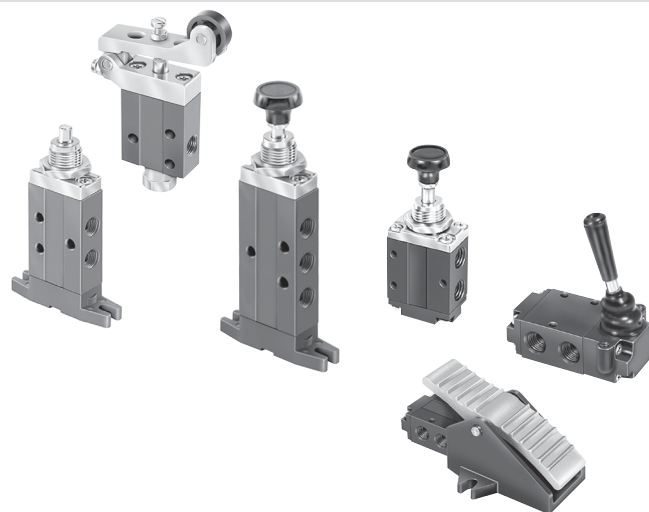

Operating information

Operating pressure	Vacuum to 150 PSI (28 inHg to 1035 kPa)*
Temperature range	32°F to 175°F (0°C to 80°C)
* Poppet valves cannot be used for vacuum. Minimum operating pressure = 0 PSIG.	

CAUTION:
If it is possible that the ambient temperature may fall below freezing, the medium must be moisture free to prevent internal damage or unpredictable behavior.

Lubrication

For maximum service life use clean, lubricated air. Valves are shipped pre-lubricated and can be operated without additional lubrication with reduced service life.

Suggested Lubricant

F442 Oil

Mechanically operated actuating forces in lbs. 1/4" Directair 4 valves

	2-Position Spring Return	2-Position Manual Return	3-Position Spring Return	3-Position Manual Return
Button Actuator	13.0	2.0	13.0	N/A
Roller Actuator	13.0	N/A	N/A	N/A
Lever Actuator	4.0	2.0	4.0	2.5

Notes: N/A = Not Applicable
All valves are at 100 PSIG inlet pressure to the valve.

Directair 2 & 4 Series

Viking Xtreme Lever Series

42 Lever / Pedal Series

MO Series

Safety



Manual / Mechanical Valves

Brass Poppet / Sliding Seal











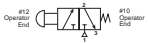
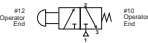
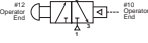

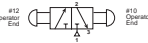
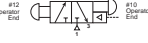
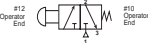

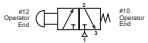
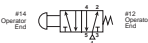
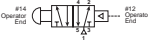
Control Panel Products

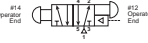
Sensing

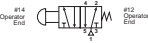
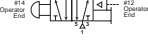

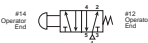
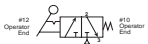
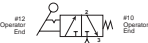
For inventory, lead times, and kit lookup, visit www.pdnplu.com

3-way & 4-way Valves

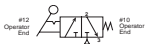
	Symbol	Port size	Cv	Description	Valve type	Part number		
        		1/8"	.17	3-way, spring return	Poppet	404411000		
			1/8"	.20	3-way, spring return	Spool	414411000	
			1/8"	.20	3-way, spring return, foot mounted	Spool	414421000	
			1/8"	.20	3-way, pilot return	Spool	414451000	
			1/8"	.20	3-way, manual return	Spool	414931000	
			1/8"	.20	3-way, manual return, foot mounted	Spool	414941000	
			1/8"	.20	3-way, manual or pilot return	Spool	414951000	
			1/4"	.83	3-way, spring return	Spool	524411000	
			1/4"	.83	3-way, pilot return	Spool	524451000	
			1/4"	.83	3-way, manual return	Spool	524431000	
	        		1/8"	.20	4-way, spring return	Spool	410411000	
				1/8"	.20	4-way, spring return, foot mounted	Spool	410421000
			1/8"	.20	4-way, pilot return	Spool	410451000	
			1/8"	.20	4-way, manual return	Spool	410931000	
			1/8"	.20	4-way, manual return, foot mounted	Spool	410941000	
			1/8"	.20	4-way, manual or pilot return	Spool	410951000	
			1/4"	.83	4-way, spring return	Spool	520411000	
			1/4"	.83	4-way, pilot return	Spool	520451000	
			1/4"	.83	4-way, manual return	Spool	520431000	
    			1/8"	.17	3-way, spring return	Poppet	404811000	
				1/8"	.20	3-way, spring return	Spool	414811000
				1/8"	.20	3-way, spring return, foot mounted	Spool	414821000
			1/8"	.20	4-way, spring return	Spool	410811000	
			1/8"	.20	4-way, spring return, foot mounted	Spool	410821000	

Directair 2 & 4 Series
Viking Xtreme Lever Series
42 Lever / Pedal Series
M0 Series
Safety

Manual / Mechanical Valves
Brass Poppet / Sliding Seal
Control Panel Products
Sensing



For inventory, lead time, and kit lookup, visit www.pdnplu.com











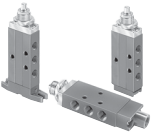



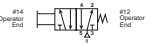
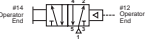



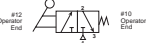
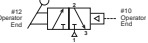
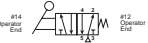

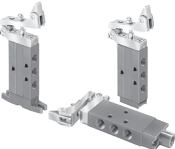
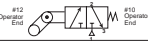
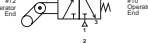
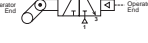

3-way & 4-way Valves

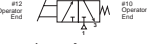
	Symbol	Port size	Cv	Description	Valve type	Part number	
Directair 2 & 4 Series Viking Xtreme Lever Series 42 Lever / Pedal Series MO Series Safety Manual / Mechanical Valves		1/4"	.83	3-way, spring return	Spool	524811000	
			1/4"	.83	3-way, manual return	Spool	524831000
			1/4"	.83	3-way, 3-Position detented, all ports blocked	Spool	523831000
			1/4"	.83	4-way, spring return	Spool	520811000
			1/4"	.83	4-way, manual return	Spool	520831000
			1/4"	.83	4-way, spring centered, closed center	Spool	521811000
			1/4"	.83	4-way, spring centered, pressure center	Spool	522811000
			1/4"	.83	4-way, spring centered, exhaust center	Spool	529811000
			1/4"	.83	4-way, detented, closed center	Spool	521831000
	Safety		1/4"	.83	4-way, detented, pressure center	Spool	522831000
			1/4"	.83	4-way, detented, exhaust center	Spool	529831000
	Roller operated Manual / Mechanical Valves		1/8"	.20	3-way, spring return	Poppet	404211000
			1/8"	.20	3-way, spring return	Spool	414211000
			1/8"	.20	3-way, spring return, foot mounted	Spool	414221000
			1/8"	.20	3-way, pilot return	Spool	414251000
			1/8"	.20	4-way, spring return	Spool	410211000
			1/8"	.20	4-way, spring return, foot mounted	Spool	410221000
			1/8"	.20	4-way, pilot return	Spool	410251000
Roller operated Brass Poppet / Sliding Seal Control Panel Products Sensing			1/4"	.83	3-way, spring return, delrin roller	Spool	524211000
			1/4"	.83	3-way, pilot return, delrin roller	Spool	524251000
			1/4"	.83	3-way, spring return, steel roller	Spool	524A11000
			1/4"	.83	3-way, pilot return, steel roller	Spool	524A51000
			1/4"	.83	4-way, spring return, delrin roller	Spool	520211000
			1/4"	.83	4-way pilot return, delrin roller	Spool	520251000
Sensing		1/4"	.83	4-way, spring return, steel roller	Spool	520A11000	
		1/4"	.83	4-way, pilot return, steel roller	Spool	520A51000	

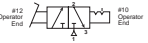
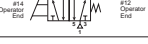

For inventory, lead times, and kit lookup, visit www.pdnplu.com

3-way & 4-way Valves

	Symbol	Port size	Cv	Description	Valve type	Part number	
Plunger operated  		1/8"	.17	3-way, spring return	Poppet	404111000	
		1/8"	.20	3-way, spring return	Spool	414111000	
		1/8"	.20	3-way, spring return, foot mounted	Spool	414121000	
		1/8"	.20	3-way, pilot return	Spool	414151000	
		1/8"	.17	4-way, spring return	Spool	410111000	
		1/8"	.20	4-way, spring return, foot mounted	Spool	410121000	
		1/8"	.20	4-way, pilot return	Spool	410151000	
	Hand lever operated  		1/8"	.17	3-way, spring return	Poppet	404711000
			1/8"	.20	3-way, spring return	Spool	414711000
			1/8"	.20	3-way, spring return, foot mounted	Spool	414721000
		1/8"	.20	3-way, pilot return	Spool	414751000	
		1/8"	.20	4-way, spring return	Spool	410711000	
		1/8"	.20	4-way, spring return, foot mounted	Spool	410721000	
		1/8"	.20	4-way, pilot return	Spool	410751000	
One way tripper operated  			1/8"	.17	3-way, spring return	Poppet	404311000
			1/8"	.20	3-way, spring return	Spool	414311000
			1/8"	.20	3-way, spring return, foot mounted	Spool	414321000
		1/8"	.20	3-way, pilot return	Spool	414351000	
		1/8"	.20	4-way, spring return	Spool	414311000	
		1/8"	.20	4-way, spring return, foot mounted	Spool	414321000	
		1/8"	.20	4-way, pilot return	Spool	414351000	
	Pedal operated 		1/4"	.83	3-way, spring return	Spool	524711000
			1/4"	.83	3-way, pilot return	Spool	524751000
			1/4"	.83	4-way, spring return	Spool	520711000
		1/4"	.83	4-way, pilot return	Spool	520751000	
 CAUTION: <i>This valve shall not be used to actuate a punch press. Do not use this valve on punch presses or press brakes. See OSHA 1910.217.</i>							
Treadle operated 		1/4"	.83	3-way, treadle operated, detented	Spool	524931000	
		1/4"	.83	4-way, treadle operated, detented	Spool	520931000	
 CAUTION: <i>This valve shall not be used to actuate a punch press. Do not use this valve on punch presses or press brakes. See OSHA 1910.217.</i>							

Directair 2 & 4 Series
Viking Xtreme Lever Series
42 Lever / Pedal Series
M0 Series
Safety

Manual / Mechanical Valves
Brass Poppet / Sliding Seal
Control Panel Products
Sensing



For inventory, lead time, and kit lookup, visit www.pdnplu.com

Ordering Information

Directair 2

41 0 1 1 1 000

Basic Series	
1/8" Port Poppet Valve	40*
1/8" Port Spool Valve	41

* Only available in Spring Return.

Manual / Mechanical	
000	Standard

Type	
4-Way, 2-Position Valve	0*
3-Way, 2-Position	4

* N/A with Basic Series 40.

Mounting	
1	Direct Pipe Ported, NPT
K	Direct Pipe Ported, BSPP

Actuation	
Plunger	1
Roller - Delrin	2
One-Way Tripper	3
Button - Spring Return	4
Hand Lever	7
Toggle	8
Button - Push-Pull	9*

* N/A with Basic Series 40.

Return	
1†	Spring
2†	Spring w/ Foot Mount
3†	None (Manual Return)
4†	None (Manual Return w/ Foot Mount)
5†	Remote Pilot Return

* Available only with Actuation 9.

† N/A with Actuation 8.

Directair 4

52 0 8 1 1 000

Basic Series	
1/4" Port Spool Valve	52

Manual / Mechanical	
000	Standard

Type	
4-Way, 2-Position Valve	0
4-Way, 3-Position, Closed Center	1*
4-Way, 3-Position, Pressure Center	2*
3-Way, 3-Position, Closed Center	3*
3-Way, 2-Position, Normally Closed	4
3-Way, 2-Position, Normally Open	6
4-Way, 3-Position, Exhaust Center	9*

* Only Available with Actuation 8 Lever.

Mounting	
1	Direct Pipe Ported, NPT
L	Direct Pipe Ported, BSPP

Return	
1††	Spring
3†	None (Manual Return)
5†	Remote Pilot Return

* N/A with Actuation 8 & 9.

† N/A with Actuation 2, 7 or A.

†† N/A with Actuation 9.

Actuation	
Roller - Delrin	2
Button	4
Pedal	7
Lever	8
Treadle	9
Roller - Metal	A



For inventory, lead times, and kit lookup, visit www.pdnplu.com

Service kits – 1/8 port size valves (DA2)

①	Spool valve seal kit (3 & 4-way, direct pipe ported)	410008000
②	Poppet valve seal kit	404118000
③	Body service kit	410008005

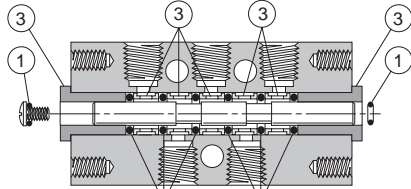

4-Way Spool

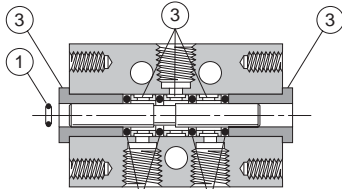

3-Way Spool

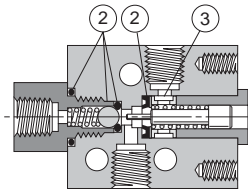

3-Way Poppet

Panel Mounting Kit – No. 520838004

Available for panel mounting direct pipe ported, lever operated 1/4" Directair 4 Series valves only. Kit includes a flange and two screws.

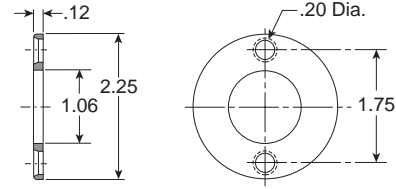

Pedal Guard Kit – No. 520718001

Pedal guard meets safety requirements for foot operated valves by protecting pedal from accidental tripping from all angles. Guard is constructed of lightweight aluminum casting for strength and durability. Bolts quickly into place with only three screws without special valve mounting. One model fits any pedal (not treadle) operated 1/4" Directair 4 Series valve.

CAUTION:
 This valve shall not be used to actuate a punch press.
 Do not use this valve on punch presses or press brakes.
 See OSHA 1910.217.

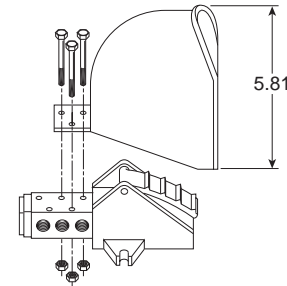

Service kits – 1/4 port size valves (DA4)

●	Valve seal kit (Contains all soft seals found in 3 & 4-way bodies and all actuator styles.) All fluorocarbon	520008050 520008500
■	Body service kit (Contains bushing, springs, retainers and shell from 2 & 3-position, 3 & 4-way bodies.)	520018005

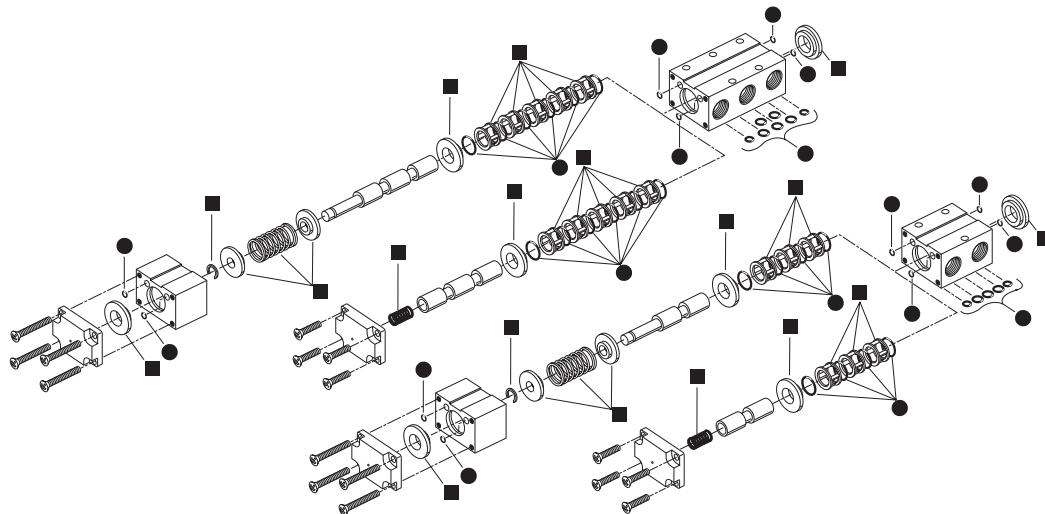

Directair 2 & 4 Series	Viking Xtreme Lever Series	42 Lever / Pedal Series	MO Series	Safety		Manual / Mechanical Valves	Brass Poppet / Sliding Seal	Control Panel Products	Sensing
------------------------	----------------------------	-------------------------	-----------	--------	--	----------------------------	-----------------------------	------------------------	---------

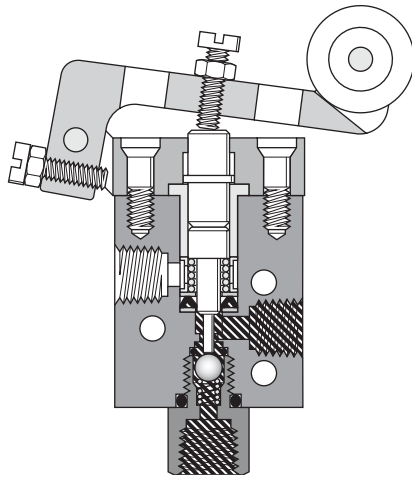

Roller Operated Poppet



Button Operated



Lever Operated

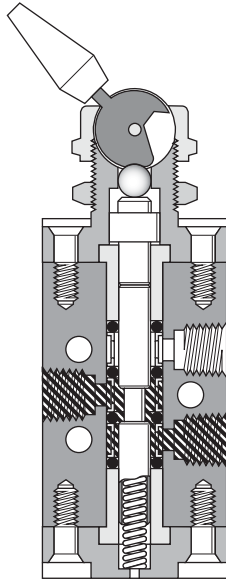

Toggle Operated Spool



Treadle Operated

 Pressure  Exhaust



For inventory, lead times, and kit lookup, visit www.pdnplu.com

Plunger, Roller, One-way Tripper & Toggle Operated — 3-Way, 3-Port, 2-Position – 1/8" Ports

Plunger Operated

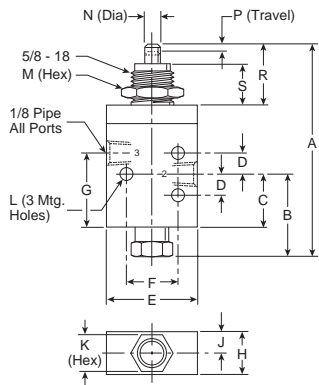

Roller Operated

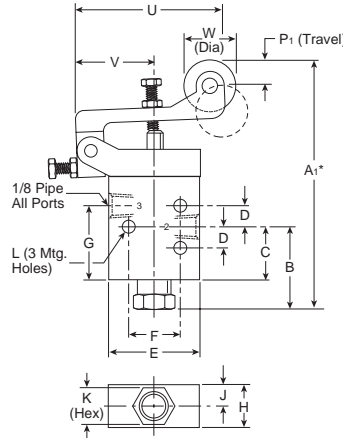

One-Way Tripper Operated

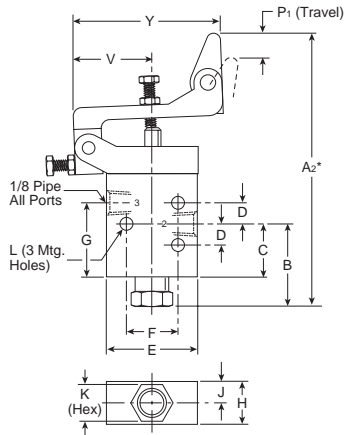

Toggle Operated

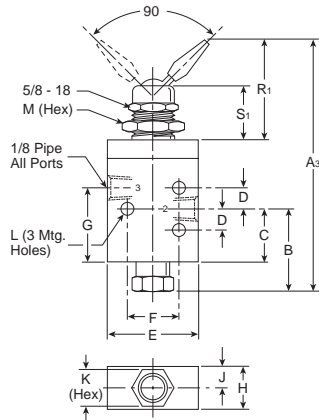

3-Way, 3-Port, 2-Position

A	A₁*	A₂*	A₃	B
3.37 (86)	4.21 (107)	4.46 (113)	3.99 (101)	1.03 (26)
C	D	E	F	G
.55 (14)	.31 (8)	1.31 (33)	.75 (19)	.90 (23)
H	J	K	L	M
.62 (16)	.31 (8)	.56 (14)	.19 (5)	.88 (22)
N	P	P₁	R	R₁
.25 (6)	.17 (4)	.38 (10)	.91 (23)	1.53 (39)
S	S₁	U	V	W
.62 (16)	.78 (20)	2.28 (58)	1.19 (30)	.75 (19)
X	Y			
.19 (5)	2.19 (56)			

* Dimensions may be reduced .44" using adjusting screw.
 Inches (mm)

Button & Hand Lever Operated — 3-Way, 3-Port, 2-Position – 1/8" Ports

Button Operated

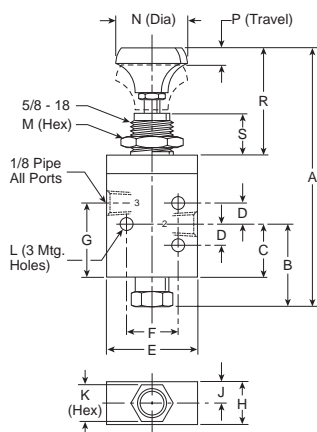

Hand Lever Operated

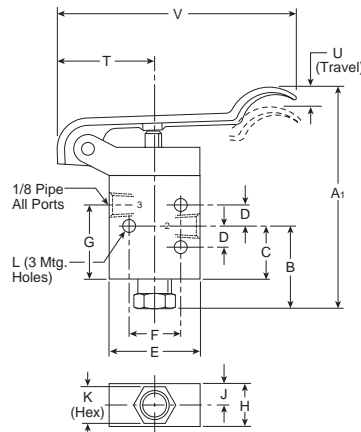

3-Way, 3-Port, 2-Position

A	A₁	B	C	D
4.13 (105)	3.34 (85)	1.03 (26)	.55 (14)	.31 (8)
E	F	G	H	J
1.31 (33)	.75 (19)	.90 (23)	.62 (16)	.31 (8)
K	L	M	N	P
.56 (14)	.19 (5)	.88 (22)	1.06 (27)	.17 (4)
R	S	T	U	V
1.67 (42)	.63 (16)	1.19 (30)	.53 (13)	3.38 (86)

Inches (mm)



For inventory, lead time, and kit lookup, visit www.pdnplu.com



Dimensional Data

Plunger, Roller, One-way Tripper & Toggle Operated — 3-Way, 3-Port, 2-Position – 1/8" Ports

Plunger Operated

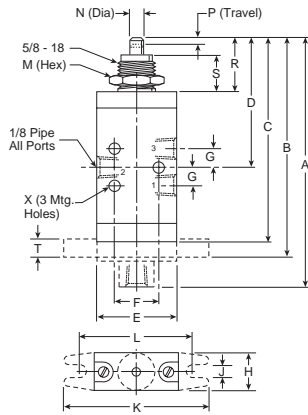

Roller Operated

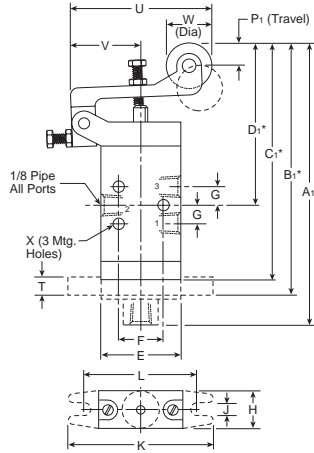

One-Way Tripper Operated

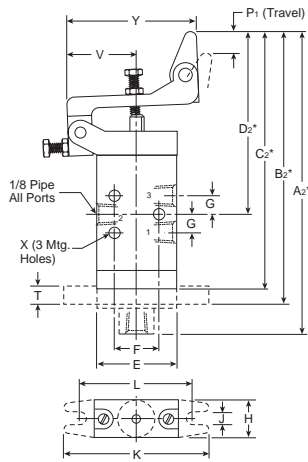

Toggle Operated

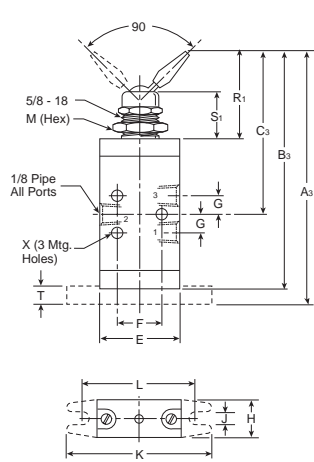

3-Way, 3-Port, 2-Position

A 4.14 (105)	A1* 4.98 (126)	A2* 5.23 (133)	A3 4.23 (107)	B 3.61 (92)
B1 4.45 (113)	B2 4.70 (119)	B3 4.00 (102)	C 3.38 (86)	C1 4.22 (107)
C2 4.47 (113)	C3 2.75 (70)	D 2.05 (52)	D1 2.98 (76)	D2 3.22 (82)
E 1.31 (33)	F .75 (19)	G .31 (8)	H .62 (16)	J .20 (5)
K 2.38 (60)	L 1.88 (48)	M .88 (22)	N .25 (6)	P .17 (4)
P1 .38 (10)	R .91 (23)	R1 1.53 (39)	S .62 (16)	S1 .78 (20)
T .25 (6)	U 2.28 (58)	V 1.19 (30)	W .75 (19)	X .19 (5)
Y 2.19 (56)				

* Dimensions may be reduced .44" using adjusting screw.
Inches (mm)

Button, Hand Lever Operated — 3-Way, 3-Port, 2-Position – 1/8" Ports

Button Operated

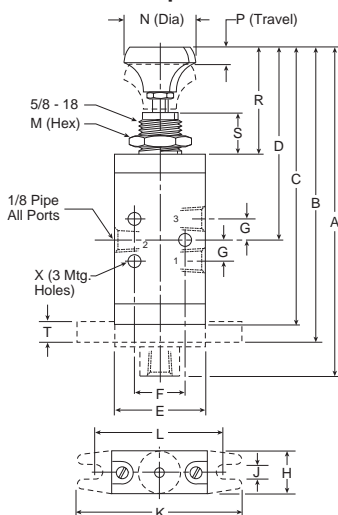

Hand Lever Operated

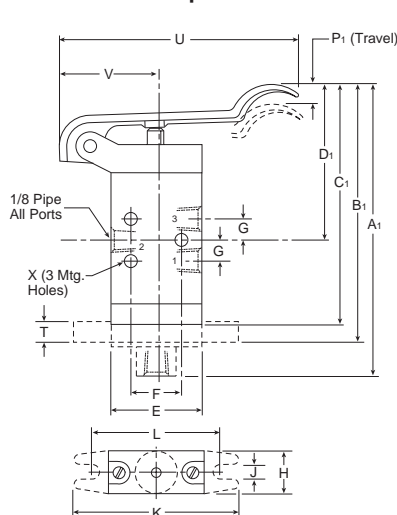

3-Way, 3-Port, 2-Position

A 5.08 (129)	A1 4.29 (109)	B 4.55 (115)	B1 3.77 (96)	C 4.31 (109)
C1 3.53 (90)	D 3.08 (78)	D1 2.29 (58)	E 1.31 (33)	F .75 (19)
G .31 (8)	H .62 (16)	J .20 (5)	K 2.38 (60)	L 1.88 (48)
M .88 (22)	N 1.06 (27)	P .17 (4)	P1 .53 (13)	R 1.67 (42)
S .63 (16)	T .25 (6)	U 3.38 (86)	V 1.19 (30)	X .19 (5)
Y .59 (15)				

Inches (mm)



For inventory, lead times, and kit lookup, visit www.pdnplu.com

Directair 2 & 4 Series
 Viking Xtreme Lever Series
 42 Lever / Pedal Series
 M0 Series
 Safety
 Manual / Mechanical Valves
 Brass Poppet / Sliding Seal
 Control Panel Products
 Sensing

Plunger, Roller, One-way Tripper & Toggle Operated — 4-Way, 5-Port, 2-Position – 1/8" Ports

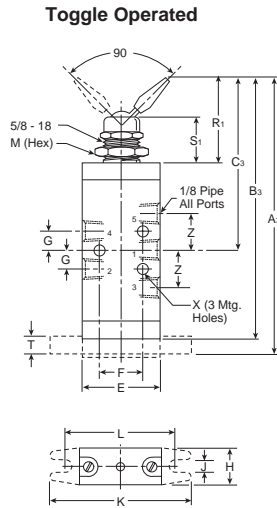
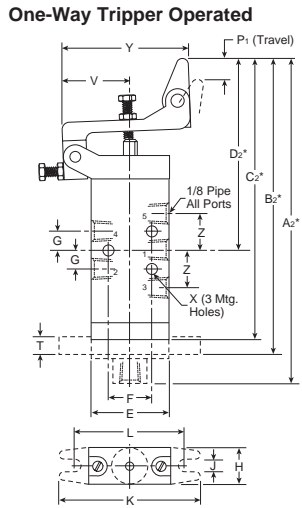
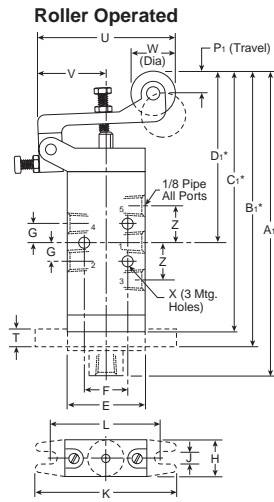
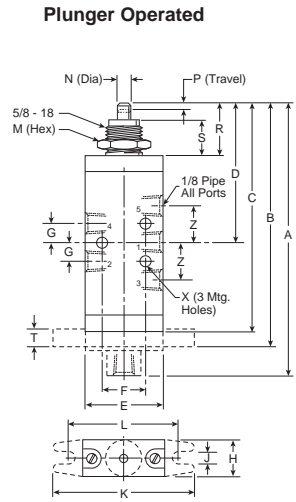

4-Way, 5-Port, 2-Position

A	A1*	A2*	A3	B
4.75 (121)	5.59 (142)	5.84 (148)	4.84 (123)	4.22 (107)
B1*	B2*	B3	C	C1*
5.06 (128)	5.31 (135)	4.61 (117)	3.99 (102)	4.83 (123)
C2*	C3	D	D1*	D2*
5.08 (129)	3.06 (78)	2.44 (62)	3.28 (83)	3.53 (90)
E	F	G	H	J
1.31 (33)	.75 (19)	.31 (8)	.62 (16)	.20 (5)
K	L	M	N	P
2.38 (60)	1.88 (48)	.88 (22)	.25 (6)	.17 (4)
P1	R	R1	S	S1
.38 (10)	.91 (23)	1.53 (39)	.62 (16)	.78 (20)
T	U	V	W	X
.25 (6)	2.28 (58)	1.19 (30)	.75 (19)	.19 (5)
Y	Z			
2.19 (56)	.62 (16)			

* Dimensions may be reduced .44" using adjusting screw.
 Inches (mm)

Button & Hand Lever Operated — 4-Way, 5-Port, 2-Position – 1/8" Ports

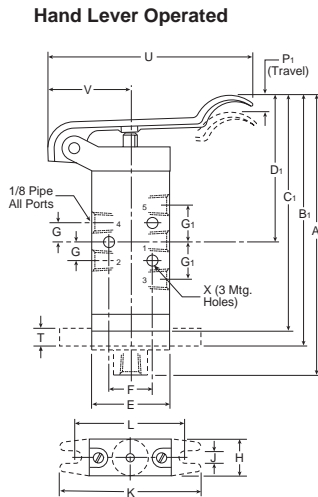
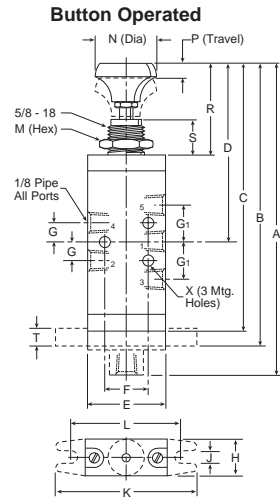

4-Way, 5-Port, 2-Position

A	A1	B	B1	C
5.69 (144)	4.90 (124)	5.16 (131)	4.38 (111)	4.92 (125)
C1	D	D1	E	F
4.14 (105)	3.67 (93)	2.90 (74)	1.31 (33)	.75 (19)
G	G1	H	J	K
.31 (8)	.63 (16)	.62 (16)	.20 (5)	2.38 (60)
L	M	N	P	P1
1.88 (48)	.88 (22)	1.06 (27)	.17 (4)	.53 (13)
R	S	T	U	V
1.67 (42)	.63 (16)	.25 (6)	3.38 (86)	1.19 (30)
X	Y			
.19 (5)	.59 (15)			

Inches (mm)



For inventory, lead time, and kit lookup, visit www.pdnplu.com

Directair 2 & 4 Series
 Viking Xtreme Lever Series
 42 Lever / Pedal Series
 MO Series
 Safety
 Manual / Mechanical Valves
 Brass Poppet / Sliding Seal
 Control Panel Products
 Sensing

Dimensional Data

Button & Roller Operated — 3-Way, 3-Port, 2-Position

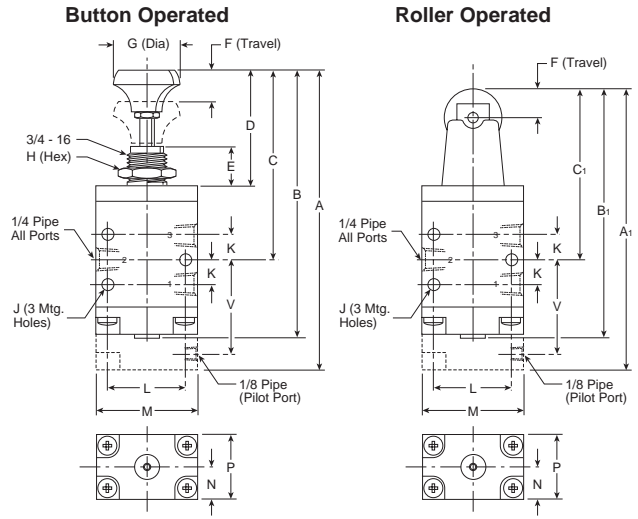

3-Way, 3-Port, 2-Position

A	A ₁	B	B ₁	C
4.91 (125)	4.25 (108)	4.44 (113)	3.78 (96)	3.10 (79)
C ₁	D	E	F	G
2.44 (62)	2.00 (51)	.63 (16)	.32 (8)	1.05 (27)
H	J	K	L	M
1.00 (25)	.19 (5)	.41 (10)	1.25 (32)	1.63 (42)
N	P	V		
.53 (14)	1.06 (27)	1.52 (39)		

Inches (mm)

Lever & Pedal Operated — 3-Way, 3-Port, 2 & 3-Position

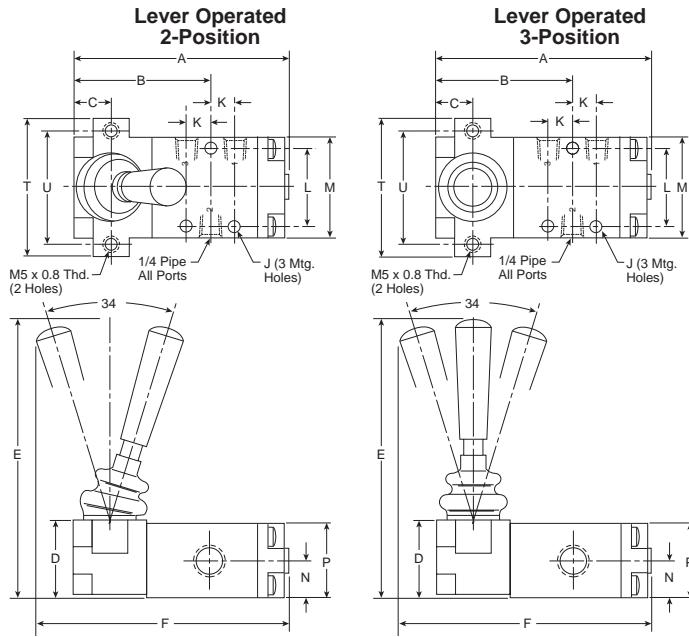

3-Way, 3-Port, 2 & 3-Position

A	A ₁	B	B ₁	C
3.31 (84)	6.55 (166)	1.97 (50)	5.20 (132)	.53 (14)
C ₁	D	E	F	J
2.19 (56)	1.12 (28)	4.06 (103)	3.90 (99)	.19 (5)
K	L	M	N	P
.41 (10)	1.25 (32)	1.63 (42)	.53 (14)	1.06 (27)
Q	R	S	T	T ₁
.37 (10)	2.40 (61)	.34 (9)	2.13 (54)	3.50 (89)
U	U ₁			
1.75 (44)	3.00 (76)			

Inches (mm)

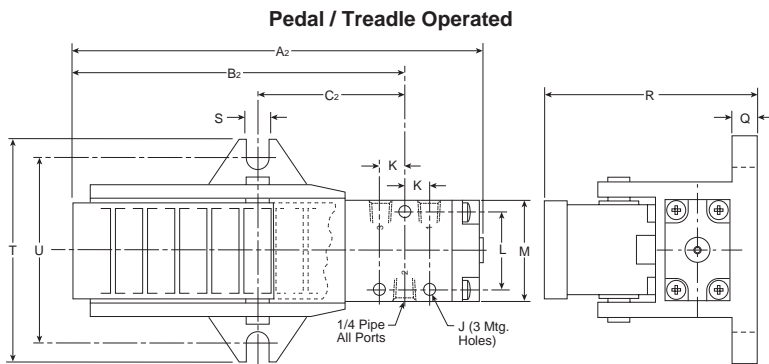

CAUTION:

This valve shall not be used to actuate a punch press. Do not use this valve on punch presses or press brakes. See OSHA 1910.217.



For inventory, lead times, and kit lookup, visit www.pdnplu.com

Directair 2 & 4 Series
 Viking Xtreme Lever Series
 42 Lever / Pedal Series
 M0 Series
 Safety
 Manual / Mechanical Valves
 Brass Poppet / Sliding Seal
 Control Panel Products
 Sensing

Button, Roller, Pedal & Treadle, Lever Operated — 4-Way, 5-Port, 2-Position

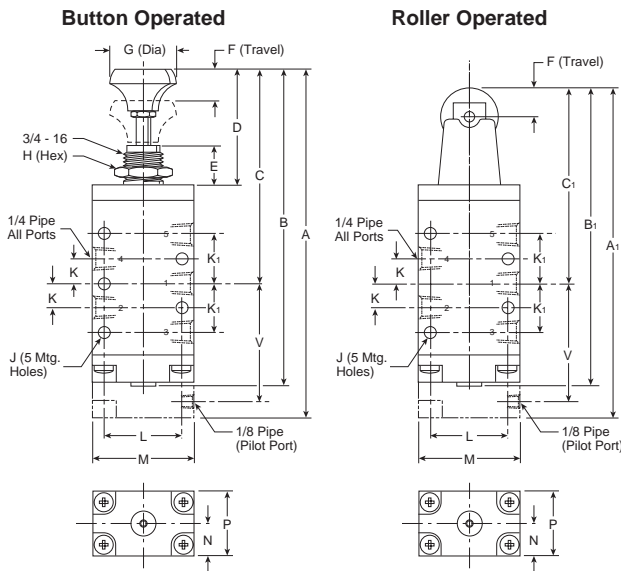

4-Way, 5-Port, 2-Position

A	A₁	A₂	B	B₁
5.75 (146)	5.13 (130)	7.41 (189)	5.28 (134)	4.66 (118)
B₂	C	C₁	C₂	D
5.63 (143)	3.50 (89)	2.88 (73)	2.64 (67)	2.00 (51)
E	F	G	H	J
.63 (16)	.32 (8)	1.05 (27)	1.00 (25)	.19 (5)
K	K₁	L	M	N
.44 (11)	.84 (21)	1.25 (32)	1.63 (41)	.53 (14)
P	Q	R	S	T
1.06 (27)	.37 (10)	2.40 (61)	.34 (9)	3.50 (89)
U	V			
3.00 (76)	1.96 (50)			

Inches (mm)

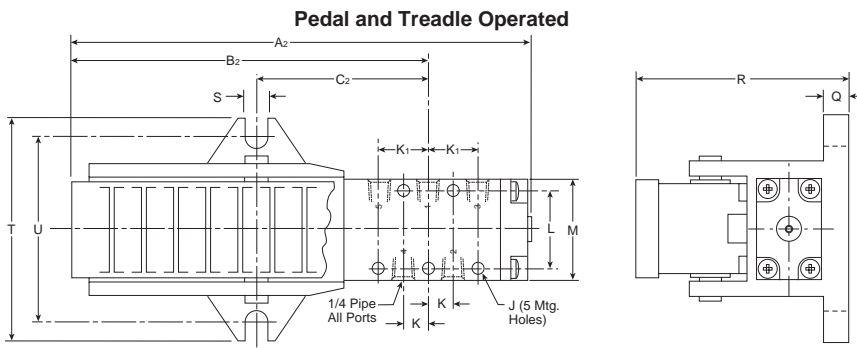

CAUTION:
 This valve shall not be used to actuate a punch press.
 Do not use this valve on punch presses or press brakes.
 See OSHA 1910.217.

Lever Operated — 4-Way, 5-Port, 2 & 3-Position

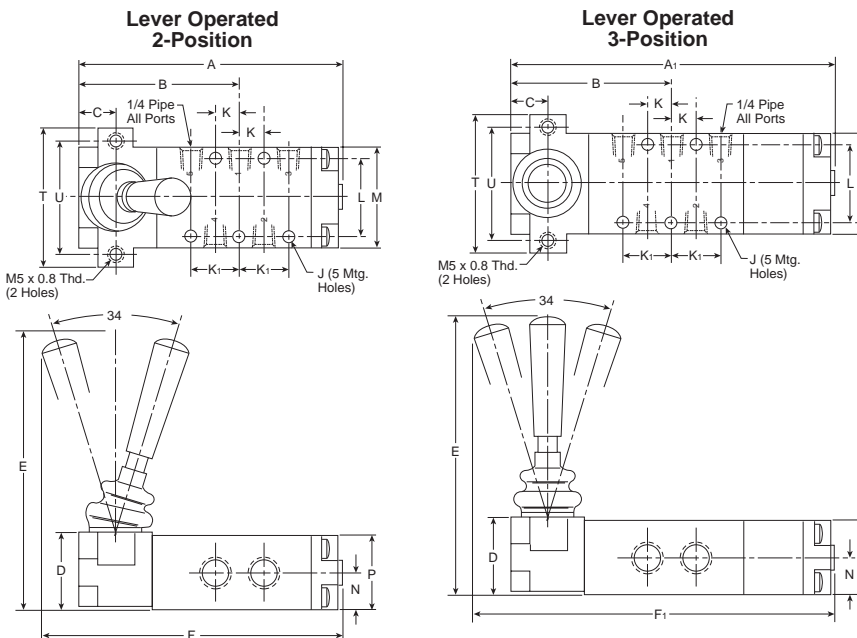

4-Way, 5-Port, 2 & 3-Position

A	A₁	B	C	D
4.19 (106)	5.09 (129)	2.41 (61)	.53 (14)	1.12 (28)
E	F	F₁	J	K
4.06 (103)	4.78 (121)	5.78 (147)	.19 (5)	.44 (11)
K₁	L	M	N	P
.84 (21)	1.25 (32)	1.63 (42)	.53 (14)	1.06 (27)
T	U			
2.13 (54)	1.75 (44)			

Inches (mm)



For inventory, lead time, and kit lookup, visit www.pdnplu.com

Directair 2
& 4 Series

Viking Xtreme
Lever Series

42 Lever/
Pedal Series

M0 Series

Safety



Manual / Mechanical
Valves

Brass Poppet /
Sliding Seal

Control Panel
Products

Sensing

Features

Viking Xtreme Manual Series

The Viking Xtreme Manual valve range is robust, versatile and combines high performance with compact installation dimensions. The valves rugged lever actuator has been specifically designed for gloved hands to suit mobile applications in the most arduous of environments. Available in 3/2, 5/2 and 5/3 functions with either spring return or detented lever. The lever actuated versions are available across the entire range from 1/8 to 1/2 port sizes.

- **Heavy duty lever**
- **Inline valve**
 - 1/8", 1/4", 3/8", 1/2" NPT & BSPP
- **2-position models**
 - 4-way & 3-way
- **3-position models**
 - all ports blocked
 - pressure center
 - center exhaust
- **Approval**
 - Canada Registration Number available (CRN)
- **Over-moulded single piece aluminium spool**
 - Reduced product complexity
 - Increased flow
 - Wide operating temperature range
 - Stable seal performance even with high flow / pressure drop across spool.



Operating information

Operating pressure: Type A & B: Vacuum to 232 PSIG (Vacuum to 16 bar Max.)
 Type C & D: Vacuum to 174 PSIG (Vacuum to 12 bar Max.)
 Temperature range: Xtreme: -40°F to 140°F (-40°C to 60°C)

Material specifications

End covers	Anodized aluminum
Lever	Reinforced polyamide plastic
Lever housing	Acetal plastic
Piston	Acetal plastic / anodized aluminum
Seals	Nitrile rubber
Screws	Stainless steel
Spool	Aluminum & nitrile rubber
Springs	Stainless steel
Valve body	Anodized aluminum

Lever Handle – 1/8" valve size, 5/2 & 5/3 only	Twist Handle – 1/4" valve sizes	Lever Handle – All other valve sizes

Features

- Variety of manual actuators
- Robust Knobs
- Stainless steel shafts
- Handle boots for ingress protection
- **Over Moulded Spool**
 - Aluminum spool with nitrile rubber coating ground to exact size for optimum performance
 - Precision ground for maximum performance
 - Wide operating temperature range
 - Low temperature to -40°
- Robust anodized aluminum valve body
- Diecast end covers with stainless steel screws to resist aggressive environments.
- Sintered bronze pilot chamber breathers provide increased protection against ingress of dust and dirt.
- The bore is polished to a very high surface finish for maximum flow capacity and long life.
- Stainless steel return spring



For inventory, lead times, and kit lookup, visit www.pdnplu.com

Directair 2
& 4 Series

Viking Xtreme
Lever Series

4/2 Lever /
Pedal Series

MO Series

Safety











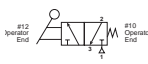

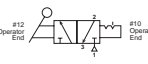

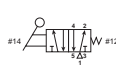

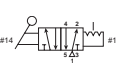
Manual / Mechanical
Valves

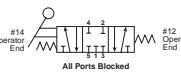
Brass Poppet /
Sliding Seal

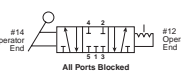
Control Panel
Products

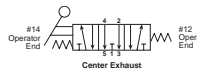
Sensing

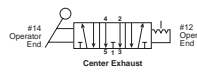
3/2 - 2-position *	Symbol	Valve type	Port size	Cv	Weight lb (kg)	Part number NPT	Part number BSPP
		Lever spring return	1/8	0.6	0.73 (0.33)	P2LAX391VS	P2LAX311VS
			1/4	1.5	0.73 (0.33)	P2LBX392VS	P2LBX312VS
			3/8	2.5	0.88 (0.40)	P2LCX393VS	P2LCX313VS
			1/2	2.7	1.32 (0.60)	P2LDX394VS	P2LDX314VS
		Lever detent	1/8	0.7	0.73 (0.33)	P2LAX391VV	P2LAX311VV
			1/4	1.3	0.73 (0.33)	P2LBX392VV	P2LBX312VV
			3/8	2.5	0.88 (0.40)	P2LCX393VV	P2LCX313VV
			1/2	2.7	1.32 (0.60)	P2LDX394VV	P2LDX314VV
<hr/>							
5/2 - 2-position *	Symbol	Valve type	Port size	Cv	Weight lb (kg)	Part number NPT	Part number BSPP
		Lever spring return	1/8	0.6	0.40 (0.18)	P2LAX591VS	P2LAX511VS
			1/4	1.5	0.73 (0.33)	P2LBX592VS	P2LBX512VS
			3/8	2.5	0.88 (0.40)	P2LCX593VS	P2LCX513VS
			1/2	2.7	1.32 (0.60)	P2LDX594VS	P2LDX514VS
		Lever detent	1/8	0.7	0.40 (0.18)	P2LAX591VV	P2LAX511VV
			1/4	1.3	0.73 (0.33)	P2LBX592VV	P2LBX512VV
			3/8	2.5	0.88 (0.40)	P2LCX593VV	P2LCX513VV
			1/2	2.7	1.32 (0.60)	P2LDX594VV	P2LDX514VV
Size P2LAX Shown							
<hr/>							
5/3 - 3-position,* all ports blocked	Symbol	Valve type	Port size	Cv	Weight lb (kg)	Part number NPT	Part number BSPP
		Lever spring center	1/8	0.6	0.40 (0.18)	P2LAX69111	P2LAX61111
			1/4	1.5	0.73 (0.33)	P2LBX69211	P2LBX61211
			3/8	2.5	1.56 (0.71)	P2LCX69311	P2LCX61311
			1/2	2.7	1.61 (0.73)	P2LDX69411	P2LDX61411
		Lever detent	1/8	0.7	0.40 (0.18)	P2LAX69122	P2LAX61122
			1/4	1.3	0.73 (0.33)	P2LBX69222	P2LBX61222
			3/8	2.5	1.56 (0.71)	P2LCX69322	P2LCX61322
			1/2	2.7	1.61 (0.73)	P2LDX69422	P2LDX61422
Size P2LAX Shown							
<hr/>							
5/3 - 3-position,* center exhaust	Symbol	Valve type	Port size	Cv	Weight lb (kg)	Part number NPT	Part number BSPP
		Lever spring center	1/8	0.6	0.40 (0.18)	P2LAX89111	P2LAX81111
			1/4	1.5	0.73 (0.33)	P2LBX89211	P2LBX81211
			3/8	2.5	1.56 (0.71)	P2LCX89311	P2LCX81311
			1/2	2.7	1.61 (0.73)	P2LDX89411	P2LDX81411
		Lever detent	1/8	0.7	0.40 (0.18)	P2LAX89122	P2LAX81122
			1/4	1.3	0.73 (0.33)	P2LBX89222	P2LBX81222
			3/8	2.5	1.56 (0.71)	P2LCX89322	P2LCX81322
			1/2	2.7	1.61 (0.73)	P2LDX89422	P2LDX81422

* Valve lever movement 90° to ports.

 Most popular.



For inventory, lead time, and kit lookup, visit www.pdnplu.com

Directair 2
& 4 Series

Viking Xtreme
Lever Series

42 Lever/
Pedal Series

M0 Series

Safety



Manual / Mechanical
Valves







Brass Poppet /
Sliding Seal

Control Panel
Products

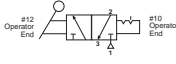
Sensing

Common Part Numbers

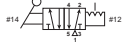
Directair 2 & 4 Series
 Viking Xtreme Lever Series
 42 Lever / Pedal Series
 MO Series
 Safety
 Manual / Mechanical Valves
 Brass Poppet / Sliding Seal
 Control Panel Products
 Sensing

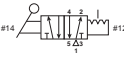
3/2 - 2-position	Symbol	Valve type	Port size	Cv	Part number NPT	Part number BSPP
		Twist handle detent	1/4	1.3 0.73 (0.33)	P2LBX392JJ	P2LBX312JJ
5/2 - 2-position	Symbol	Valve type	Port size	Cv	Part number NPT	Part number BSPP
		Twist handle detent	1/4	1.3 0.73 (0.33)	P2LBX592JJ	P2LBX512JJ
5/2 - 2-position *	Symbol	Valve type	Port size	Cv	Part number NPT	Part number BSPP
		Lever spring return	1/4	1.3 0.73 (0.33)	P2LBX592ZS	P2LBX512ZS
		Lever detent	1/4	1.3 0.73 (0.33)	P2LBX592ZZ	P2LBX512ZZ

* Valve lever movement inline to ports.

Viking Xtreme Manual Operated Valves

Vacuum to 232 PSIG (Vacuum to 16 bar) -40°F to 140°F (-40°C to 60°C)

P2L A X 5 91 VS

Valve size	
1/8"	A
1/4"	B
3/8"	C
1/2"	D

Valve type / function	
3/2 NC - 2-position	3
5/2 2-position	5
5/3 3-position, APB	6
5/3 3-position, PC	7
5/3 3-position, CE	8

Actuator / position / lever	
JJ*	Twist handle detent, 2-position
VS	Spring return lever, 2-position, 90° to ports
VV	Lever, detent, 2-position, 90° to ports
ZS**	Spring return lever, 2-position, inline to ports
ZZ**	Lever detent, 2-position, inline to ports
11	Spring centered lever, 3-position, 90° to ports
22	Lever, detent, 3-position, 90° to ports
55**	Spring return lever, 3-position, inline to ports
66**	Lever detent, 3-position, inline to ports

* Not available with 3-position valves. Available Size B only.
 ** Size B valve only.

Main port thread	
11	G1/8 (P2LA)
12	G1/4 (P2LB)
1N*	G1/4 (P2LB) NAMUR mount
13	G3/8 (P2LC)
14	G1/2 (P2LD)
91	1/8" NPT (P2LA)
92	1/4" NPT (P2LB)
9N*	1/4 NPT (P2LB) NAMUR mount
93	3/8" NPT (P2LC)
94	1/2" NPT (P2LD)

 Most popular.

* 5/2, 2-position valve only.



For inventory, lead times, and kit lookup, visit www.pdnplu.com

Exhaust Mufflers

Pipe thread	Part number
M5	P6M-PAC5
1/8" NPT	EM12
1/4" NPT	EM25
3/8" NPT	EM37
1/2" NPT	EM50

P6M - Plastic; EM - Sintered bronze



Plastic Silencers

Thread size	Part number			A (mm)	B (mm)
	NPT	BSPT	Metric		
M5			AS-5	.43 (11)	.32 (8)
1/8"	ASN-6	AS-6		1.57 (40)	.63 (16)
1/4"	ASN-8	AS-8		2.56 (65)	.83 (21)
3/8"	ASN-10	AS-10		3.35 (85)	.98 (25)
1/2"	ASN-15	AS-15		3.74 (95)	1.18 (30)

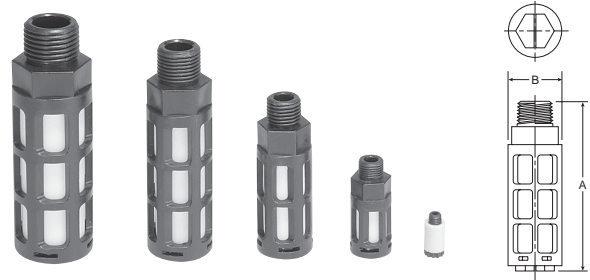

Exhaust Protector

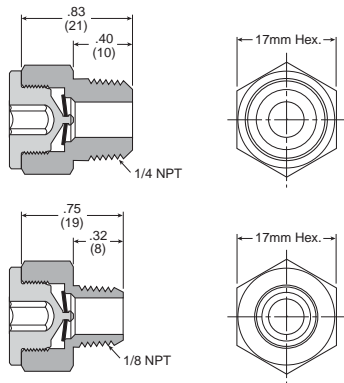

Specifications

Operating pressure 0 – 150 PSIG
(0 to 10 bar, 0 to 1034 kPa)

Operating temperature -40°F to 158°F (-40°C to 70°C)

Material:

Body and pipe adapter Brass
Membrane Fluorocarbon

Flow Data (SCFM)

Part number	Size	60 PSIG inlet	90 PSIG inlet	125 PSIG inlet
E90016	1/8"	40.1	56.5	75.5
E90017	1/4"	44.6	62.7	83.5

Features

- 1/8 and 1/4 NPT male sizes
- Fitted with a brass pipe adapter and a fluorocarbon membrane
- Resistant to rust, clog, wash down and contamination

Applications

These protectors are intended for mobile applications, quick venting applications and alternative exhaust port breathers that require protection against clogging.

Ideal for valves exposed to harsh environmental conditions (which can cause a “caking up” in the exhaust pipe ports where the bronze mufflers or breather vents are installed).

Particularly suitable for time-sensitive applications such as axle-lift suspensions or pushers or tag axles.

Directair 2 & 4 Series

Viking Xtreme Lever Series

42 Lever / Pedal Series

M0 Series

Safety



Manual / Mechanical Valves

Brass Poppet / Sliding Seal

Control Panel Products

Sensing



For inventory, lead time, and kit lookup, visit www.pdnplu.com

Dimensional Data

P2LAX 3/2 Hand Lever Operated
 Lever operation 90° to ports movement

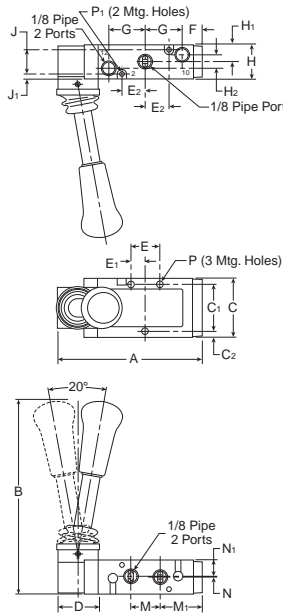

P2LAX 3/2

A	B	C
3.88 (99)	5.23 (133)	1.57 (40)
C ₁	C ₂	D
1.26 (32)	.16 (4)	1.06 (27)
E	E ₁	E ₂
.79 (20)	.39 (10)	.63 (16)
F	G	H
.55 (14)	.98 (25)	.87 (22)
H ₁	H ₂	J
.42 (10.6)	.02 (0.5)	.65 (16.5)
J ₁	M	M ₁
.11 (2.9)	.79 (20)	1.14 (29)
N	N ₁	P
.18 (4.5)	.26 (6.6)	Ø .17 (Ø 4.3)
P ₁	Ø .12 (Ø 3.1)	

Inches (mm)

P2LAX 5/2 & 5/3 Hand Lever Operated
 Lever operation 90° to ports movement

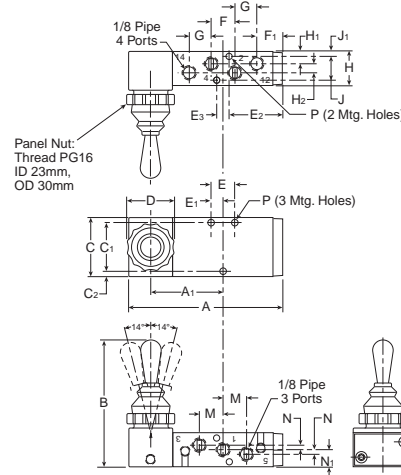

P2LAX 5/2 & 5/3

A	A ₁	B
4.02 (102)	1.89 (48)	3.23 (82)
C	C ₁	C ₂
1.57 (40)	1.30 (33)	.14 (3.5)
D	E ₂	E ₃
1.18 (30)	1.42 (36)	.33 (8.5)
F	F ₁	G
.63 (16)	.67 (17)	.59 (15)
H	H ₁	H ₂
.87 (22)	.31 (8)	.24 (6)
J	J ₁	M
.63 (16)	.12 (3)	.63 (16)
N	N ₁	P
.12 (3)	.43 (11)	Ø .16 (Ø 4.1)

Inches (mm)

P2LBX 3/2 Hand Lever Operated
 Lever operation 90° to ports movement

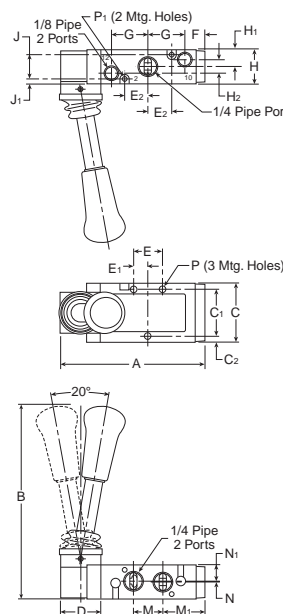

P2LBX 3/2

A	B	C
3.88 (99)	5.23 (133)	1.57 (40)
C ₁	C ₂	D
1.26 (32)	.16 (4)	1.06 (27)
E	E ₁	E ₂
.79 (20)	.39 (10)	.63 (16)
F	G	H
.55 (14)	.98 (25)	.87 (22)
H ₁	H ₂	J
.42 (10.6)	.02 (0.5)	.65 (16.5)
J ₁	M	M ₁
.11 (2.9)	.79 (20)	1.14 (29)
N	N ₁	P
.18 (4.5)	.26 (6.6)	Ø .17 (Ø 4.3)
P ₁	Ø .12 (Ø 3.1)	

Inches (mm)

P2LBX 5/2 & 5/3 Hand Lever Operated
 Lever operation 90° to ports movement

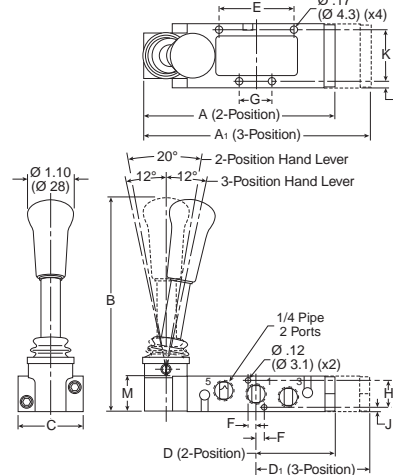

P2LBX 5/2 & 5/3

A	A ₁	B	
4.67 (118.5)	5.51 (140)	5.19 (131.8)	
C	D	D ₁	
1.57 (40)	1.93 (49)	2.35 (59.8)	
E	F	G	
1.81 (46)	.20 (5)	.79 (20)	
H	J	K	
.65 (16.5)	.11 (2.85)	1.26 (32)	
L	M		
.16 (4)	.87 (22.2)		

Inches (mm)



For inventory, lead times, and kit lookup, visit www.pdnplu.com

E17-a

Parker Hannifin Corporation
 Pneumatic Division
 Richland, Michigan
www.parker.com/pneumatics

Directair 2 & 4 Series
 Viking Xtreme Lever Series
 42 Lever / Pedal Series
 M0 Series
 Safety
 Manual / Mechanical Valves
 Brass Poppet / Sliding Seal
 Control Panel Products
 Sensing

Dimensional Data

P2LCX 3/2 Hand Lever Operated
 Lever operation 90° to ports movement

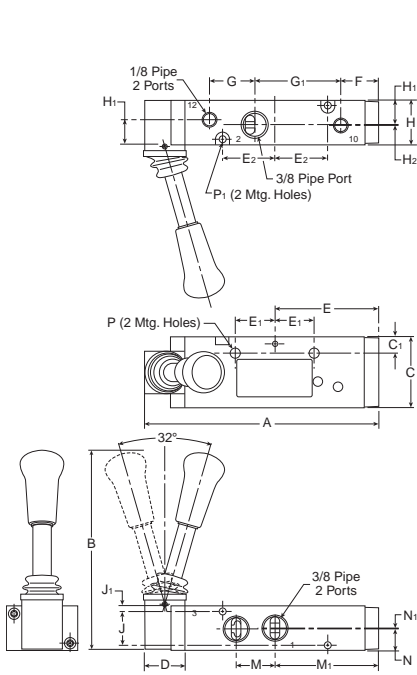

P2LCX 3/2

A	B	C
6.20 (158)	5.36 (136)	1.89 (48)
C ₁	D	E
.43 (11)	1.06 (27)	2.76 (70)
E ₁	E ₂	F
1.04 (27)	1.40 (36)	1.02 (26)
G	G ₁	H
1.22 (31)	2.24 (57)	1.18 (30)
H ₁	H ₂	J
.67 (17)	.02 (0.5)	.91 (23)
J ₁	M	M ₁
.14 (3.5)	1.18 (30)	2.76 (70)
N	N ₁	P
.59 (15)	.04 (1)	Ø .27 (Ø 6.9)
P ₁	Ø .17 (Ø 4.4)	

Inches (mm)

P2LCX 5/2 & 5/3 Hand Lever Operated
 Lever operation 90° to ports movement

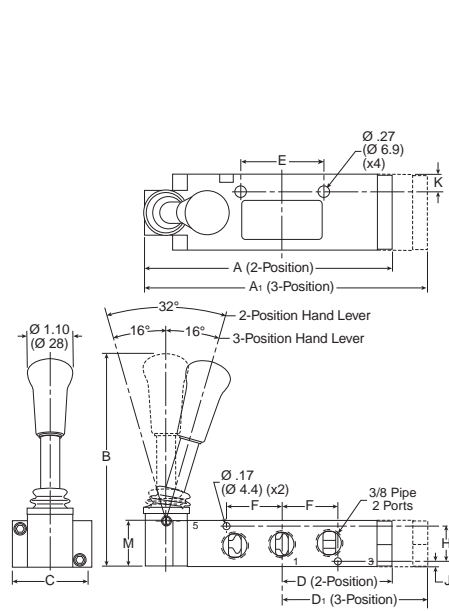

P2LCX 5/2 & 5/3

A	A ₁	B
6.20 (157.5)	7.07 (179.5)	5.36 (136.3)
C	D	D ₁
1.89 (48)	2.76 (70)	3.19 (81)
E	F	H
2.09 (53)	1.40 (35.5)	.91 (23)
J	K	M
.14 (3.5)	.43 (11)	1.18 (30)

Inches (mm)

P2LDX 3/2 Hand Lever Operated
 Lever operation 90° to ports movement

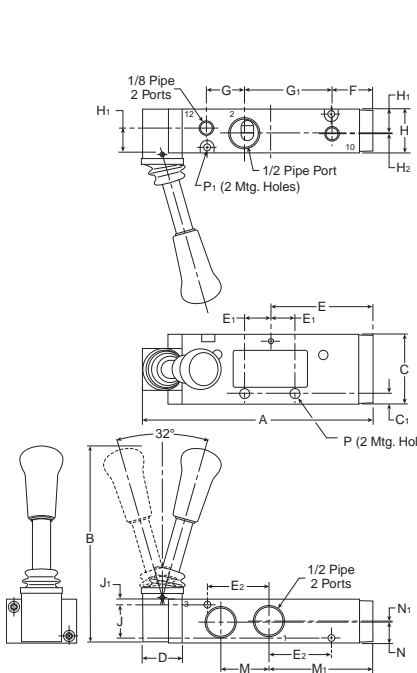

P2LDX 3/2

A	B	C
6.20 (158)	5.36 (136)	1.89 (48)
C ₁	D	E
.30 (7.5)	1.06 (27)	2.76 (70)
E ₁	E ₂	F
.67 (17)	1.65 (42)	1.08 (28)
G	G ₁	H
.98 (25)	2.36 (60)	1.18 (30)
H ₁	H ₂	J
.67 (17)	.02 (0.5)	.91 (23)
J ₁	M	M ₁
.14 (3.5)	1.30 (33)	2.76 (70)
N	N ₁	P
.59 (15)	.04 (1)	Ø .26 (Ø 6.6)
P ₁	Ø .17 (Ø 4.4)	

Inches (mm)

P2LDX 5/2 & 5/3 Hand Lever Operated
 Lever operation 90° to ports movement

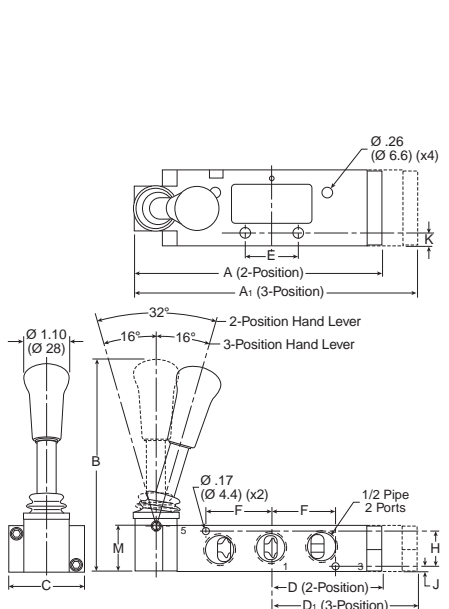

P2LDX 5/2 & 5/3

A	A ₁	B
6.20 (157.5)	7.07 (179.5)	5.36 (136.3)
C	D	D ₁
1.89 (48)	3.19 (81)	2.76 (70)
E	F	H
1.34 (34)	1.65 (42)	.91 (23)
J	K	M
.14 (3.5)	.30 (7.5)	1.18 (30)

Inches (mm)



For inventory, lead time, and kit lookup, visit www.pdnplu.com

Directair 2
& 4 Series

Viking Xtreme
Lever Series

42 Lever/
Pedal Series

MO Series

Safety



Manual / Mechanical
Valves

Brass Poppet /
Sliding Seal

Control Panel
Products

Sensing

P2LBX 3/2 Twist Lever Operated

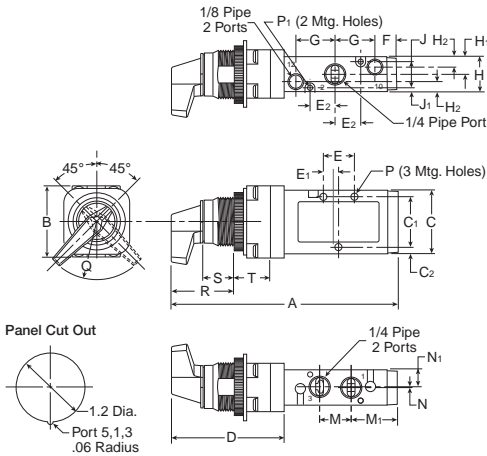

P2LBX 3/2

A	B	C	C ₁	C ₂	D	E	E ₁	E ₂
5.67 (144)	1.79 (45.5)	1.57 (40)	1.26 (32)	.16 (4)	2.87 (73)	.79 (20)	.39 (10)	.63 (16)
F	G	H	H ₁	H ₂	J	J ₁	M	M ₁
.55 (14)	.98 (25)	.87 (22.2)	.44 (11.1)	.26 (6.6)	.65 (16.5)	.11 (2.9)	.79 (20)	1.14 (29)
N	N ₁	P	P ₁	Q	R	S	T	
.02 (0.5)	.42 (10.6)	∅ .17 (4.3)	∅ .12 (3.1)	1.5R (38.1)R	1.85 (47)	1.10 (28)	.67 (17)	

Inches (mm)

P2LBX 5/2 Twist Lever Operated

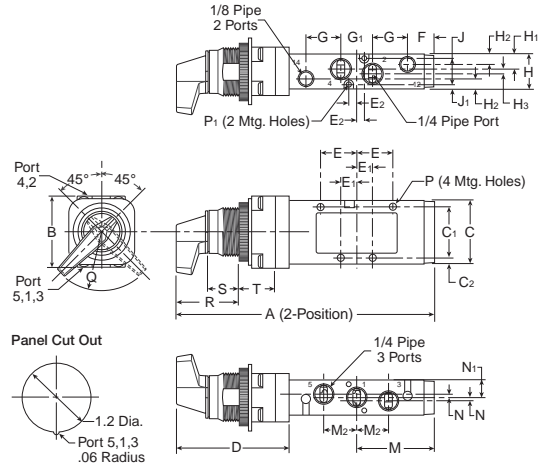

P2LBX 5/2

A	B	C	C ₁	C ₂	D	E	E ₁	E ₂	F
6.46 (164)	1.79 (45.5)	1.57 (40)	1.26 (32)	.15 (4)	2.87 (73)	.91 (23)	.39 (10)	.20 (5)	.67 (17)
G	G ₁	H	H ₁	H ₂	H ₃	J	J ₁	M	M ₂
.87 (22)	.79 (20)	.87 (22.2)	.44 (11.1)	.26 (6.6)	.12 (3)	.65 (16.5)	.11 (2.9)	1.93 (49)	.79 (20)
N	N ₁	P	P ₁	Q	R	S	T		
.08 (0.2)	.44 (11.1)	∅ .17 (4.3)	∅ .12 (3.1)	1.5R (38.1)R	1.85 (47)	1.10 (28)	.67 (17)		

Inches (mm)

P2LBX 3/2 Knob Lever Operated
 Lever operation inline with ports

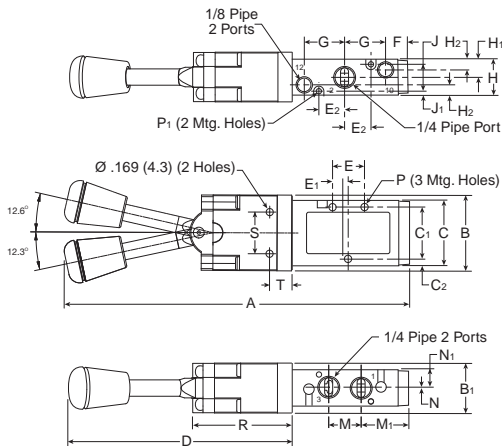

P2LBX 3/2

A	B	B ₁	C	C ₁	C ₂	D	E	E ₁
8.19 (208)	1.79 (45.5)	1.2 (30.5)	1.57 (40)	1.26 (32)	.16 (4)	5.39 (137)	.79 (20)	.39 (10)
E ₂	F	G	H	H ₁	H ₂	J	J ₁	M
.63 (16)	.55 (14)	.98 (25)	.87 (22.2)	.44 (11.1)	.26 (6.6)	.65 (16.5)	.11 (2.9)	.79 (20)
M ₁	N	N ₁	P	P ₁	R	S	T	
1.14 (29)	.02 (0.5)	.42 (10.6)	∅ .17 (4.3)	∅ .12 (3.1)	2.38 (60.5)	.98 (25.0)	.52 (13.2)	

Inches (mm)

P2LBX 5/2 & 5/3 Knob Lever Operated
 Lever operation inline with ports

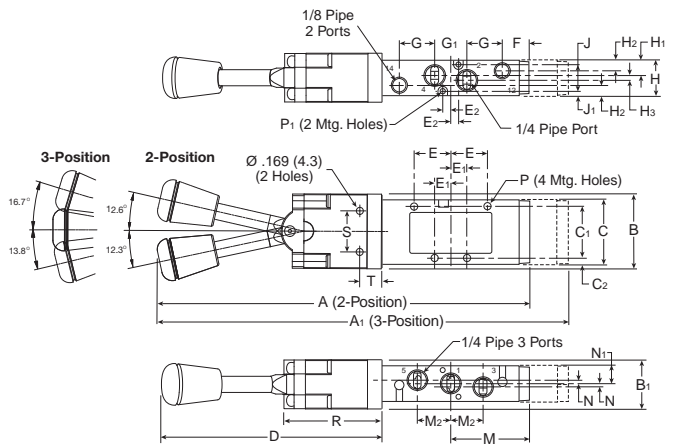

P2LBX 5/2 & 5/3

A	A ₁	B	B ₁	C	C ₁	C ₂	D	E	E ₁
8.97 (228)	9.84 (250)	1.79 (45.5)	1.2 (30.5)	1.57 (40)	1.26 (32)	.15 (4)	5.39 (137)	.91 (23)	.39 (10)
E ₂	F	G	G ₁	H	H ₁	H ₂	H ₃	J	J ₁
.20 (5)	.67 (17)	.87 (22)	.79 (20)	.87 (22.2)	.44 (11.1)	.26 (6.6)	.12 (3)	.65 (16.5)	.11 (2.9)
M	M ₂	N	N ₁	P	P ₁	R	S	T	
1.93 (49)	.79 (20)	.08 (0.2)	.44 (11.1)	∅ .17 (4.3)	∅ .12 (3.1)	2.38 (60.5)	.98 (25.0)	.52 (13.2)	

Inches (mm)



For inventory, lead times, and kit lookup, visit www.pdnplu.com

Directair 2 & 4 Series
 Viking Xtreme Lever Series
 4:2 Lever / Pedal Series
 M0 Series
 Safety
 Manual / Mechanical Valves
 Brass Poppet / Sliding Seal
 Control Panel Products
 Sensing

P2LBX 3/2 Twist Lever Operated

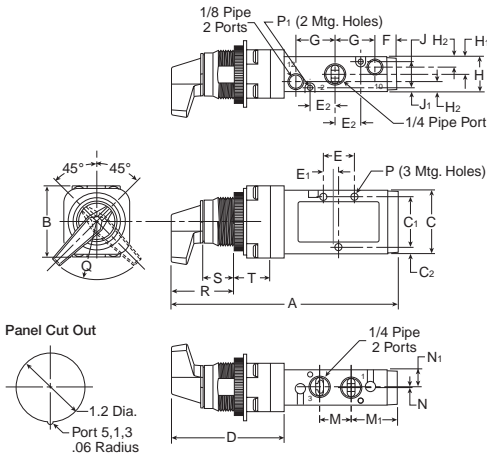

P2LBX 3/2

A	B	C	C ₁	C ₂	D	E	E ₁	E ₂
5.67 (144)	1.79 (45.5)	1.57 (40)	1.26 (32)	.16 (4)	2.87 (73)	.79 (20)	.39 (10)	.63 (16)
F	G	H	H ₁	H ₂	J	J ₁	M	M ₁
.55 (14)	.98 (25)	.87 (22.2)	.44 (11.1)	.26 (6.6)	.65 (16.5)	.11 (2.9)	.79 (20)	1.14 (29)
N	N ₁	P	P ₁	Q	R	S	T	
.02 (0.5)	.42 (10.6)	∅ .17 (4.3)	∅ .12 (3.1)	1.5R (38.1)R	1.85 (47)	1.10 (28)	.67 (17)	

Inches (mm)

P2LBX 5/2 Twist Lever Operated

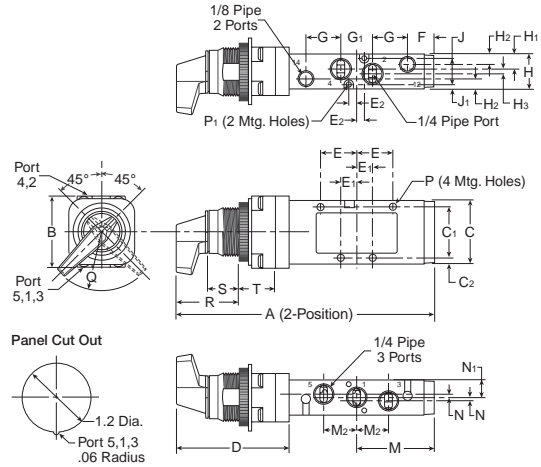

P2LBX 5/2

A	B	C	C ₁	C ₂	D	E	E ₁	E ₂	F
6.46 (164)	1.79 (45.5)	1.57 (40)	1.26 (32)	.15 (4)	2.87 (73)	.91 (23)	.39 (10)	.20 (5)	.67 (17)
G	G ₁	H	H ₁	H ₂	H ₃	J	J ₁	M	M ₂
.87 (22)	.79 (20)	.87 (22.2)	.44 (11.1)	.26 (6.6)	.12 (3)	.65 (16.5)	.11 (2.9)	1.93 (49)	.79 (20)
N	N ₁	P	P ₁	Q	R	S	T		
.08 (0.2)	.44 (11.1)	∅ .17 (4.3)	∅ .12 (3.1)	1.5R (38.1)R	1.85 (47)	1.10 (28)	.67 (17)		

Inches (mm)

P2LBX 3/2 Knob Lever Operated
 Lever operation inline with ports

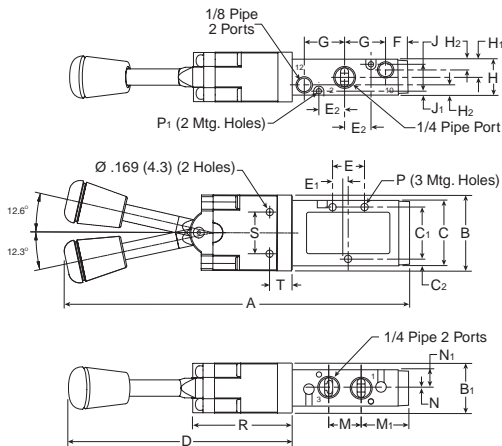

P2LBX 3/2

A	B	B ₁	C	C ₁	C ₂	D	E	E ₁
8.19 (208)	1.79 (45.5)	1.2 (30.5)	1.57 (40)	1.26 (32)	.16 (4)	5.39 (137)	.79 (20)	.39 (10)
E ₂	F	G	H	H ₁	H ₂	J	J ₁	M
.63 (16)	.55 (14)	.98 (25)	.87 (22.2)	.44 (11.1)	.26 (6.6)	.65 (16.5)	.11 (2.9)	.79 (20)
M ₁	N	N ₁	P	P ₁	R	S	T	
1.14 (29)	.02 (0.5)	.42 (10.6)	∅ .17 (4.3)	∅ .12 (3.1)	2.38 (60.5)	.98 (25.0)	.52 (13.2)	

Inches (mm)

P2LBX 5/2 & 5/3 Knob Lever Operated
 Lever operation inline with ports

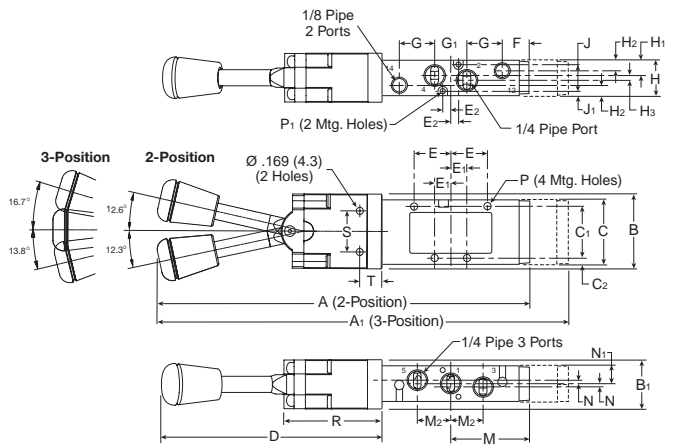

P2LBX 5/2 & 5/3

A	A ₁	B	B ₁	C	C ₁	C ₂	D	E	E ₁
8.97 (228)	9.84 (250)	1.79 (45.5)	1.2 (30.5)	1.57 (40)	1.26 (32)	.15 (4)	5.39 (137)	.91 (23)	.39 (10)
E ₂	F	G	G ₁	H	H ₁	H ₂	H ₃	J	J ₁
.20 (5)	.67 (17)	.87 (22)	.79 (20)	.87 (22.2)	.44 (11.1)	.26 (6.6)	.12 (3)	.65 (16.5)	.11 (2.9)
M	M ₂	N	N ₁	P	P ₁	R	S	T	
1.93 (49)	.79 (20)	.08 (0.2)	.44 (11.1)	∅ .17 (4.3)	∅ .12 (3.1)	2.38 (60.5)	.98 (25.0)	.52 (13.2)	

Inches (mm)



For inventory, lead times, and kit lookup, visit www.pdnplu.com

Directair 2 & 4 Series
 Viking Xtreme Lever Series
 4:2 Lever / Pedal Series
 M0 Series
 Safety
 Manual / Mechanical Valves
 Brass Poppet / Sliding Seal
 Control Panel Products
 Sensing

68PM Male Connector

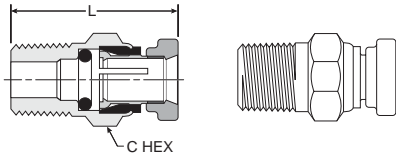

Part number	Tube size	Pipe thread (NPTF)	C hex	L
68PM-2-1	1/8	1/16	3/82	0.93
68PM-2-2	1/8	1/8	7/16	0.88
68PM-5/32-1	5/32	1/16	3/8	0.95
68PM-5/32-2	5/32	1/8	7/16	0.74
68PM-5/32-4	5/32	1/4	9/16	0.99
68PM-3-1	3/16	1/16	7/16	0.95
68PM-3-2	3/16	1/8	7/16	0.92
68PM-3-4	3/16	1/4	9/16	1.10

68PMT Male Connector

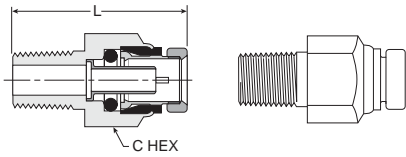

Part number	Tube size	Pipe thread (NPTF)	C hex	L
68PMT-4-2	1/4	1/8	1/2	1.06
68PMT-4-4	1/4	1/4	9/16	1.19
68PMT-4-6	1/4	3/8	3/4	1.27
68PMT-6-2	3/8	1/8	3/4	1.37
68PMT-6-4	3/8	1/4	3/4	1.43
68PMT-6-6	3/8	3/8	3/4	1.33
68PMT-6-8	3/8	1/2	7/8	1.38
68PMT-8-4	1/2	1/4	7/8	1.72
68PMT-8-6	1/2	3/8	7/8	1.52
68PMT-8-8	1/2	1/2	7/8	1.44
68PMT-10-6	5/8	3/8	1	1.88
68PMT-10-8	5/8	1/2	1	1.88
68PMT-12-8	3/4	1/2	1-3/16	2.03

169PMNS Male Elbow Non-Swivel 90°

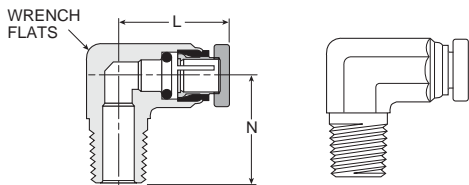

Part number	Tube size	Pipe thread (NPTF)	Wrench flats	L	N
169PMNS-2-2	1/8	1/8	3/8	0.86	0.68
169PMNS-5/32-2	5/32	1/8	3/8	0.88	0.68
169PMNS-3-2	3/16	1/8	3/8	0.75	0.67
169PMNS-3-4	3/16	1/4	1/2	0.74	0.93

169PMT Male Elbow Swivel 90°

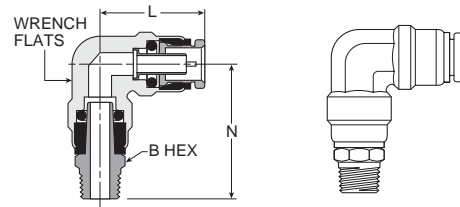

Part number	Tube size	Pipe Thread (NPTF)	Wrench flats	B hex	L	N
169PMT-4-2	1/4	1/8	13/32	7/16	0.84	1.21
169PMT-4-4	1/4	1/4	13/32	9/16	0.84	1.43
169PMT-4-6	1/4	3/8	13/32	11/16	0.84	1.43
169PMT-6-2	3/8	1/8	9/16	9/16	1.11	1.41
169PMT-6-4	3/8	1/4	9/16	9/16	1.11	1.58
169PMT-6-6	3/8	3/8	9/16	11/16	1.11	1.58
169PMT-6-8	3/8	1/2	9/16	7/8	1.11	1.79
169PMT-8-4	1/2	1/4	11/16	5/8	1.27	1.73
169PMT-8-6	1/2	3/8	11/16	3/4	1.27	1.81
169PMT-8-8	1/2	1/2	11/16	7/8	1.27	1.96
169PMT-10-6	5/8	3/8	7/8	3/4	1.53	2.03
169PMT-10-8	5/8	1/2	7/8	7/8	1.53	2.18

169PMTL Male Elbow Long Non-Swivel 90°

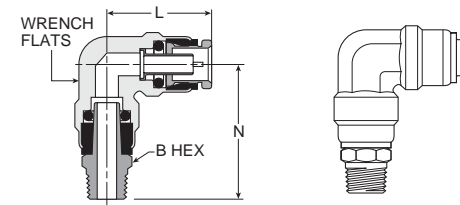

Part number	Tube size	Pipe Thread (NPTF)	Wrench flats	B hex	L	N
169PMTL-6-4	3/8	1/4	9/16	9/16	1.06	1.63
169PMTL-6-6	3/8	3/8	9/16	7/8	1.19	2.50
169PMTL-6-8	3/8	1/2	9/16	7/8	1.19	2.50
169PMTL-8-8	1/2	1/2	11/16	7/8	1.22	2.50
169PMTL-10-8	5/8	1/2	7/8	7/8	1.46	2.50



For inventory, lead time, and kit lookup, visit www.pdnplu.com



Dimensional Data

169PMTNS Male Elbow Non-Swivel 90°

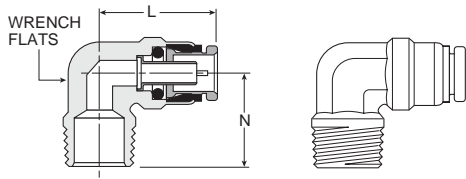

Part number	Tube size	Pipe thread (NPTF)	Wrench flats	L	N
169PMTNS-4-2	1/4	1/8	1/2	0.84	0.72
169PMTNS-4-4	1/4	1/4	1/2	0.84	0.90
169PMTNS-4-6	1/4	3/8	1/2	0.84	1.06
169PMTNS-6-2	3/8	1/8	9/16	1.05	0.75
169PMTNS-6-4	3/8	1/4	9/16	1.05	0.94
169PMTNS-6-6	3/8	3/8	3/4	1.05	0.94
169PMTNS-6-8	3/8	1/2	11/16	1.12	1.26
169PMTNS-8-4	1/2	1/4	11/16	1.17	1.06
169PMTNS-8-6	1/2	3/8	11/16	1.22	1.06
169PMTNS-8-8	1/2	1/2	11/16	1.22	1.26
169PMTNS-10-6	5/8	3/8	7/8	1.46	1.11
169PMTNS-10-8	5/8	1/2	7/8	1.46	1.32
169PMTNS-12-8	3/4	1/2	1	1.81	1.44

171PMTNS Male Run Tee Non-Swivel

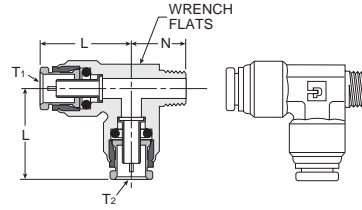

Part number	Tube 1 size	Tube 2 size	Pipe thread (NPTF)	Wrench flats	L1	L2	N
171PMTNS-4-4	1/4	1/4	1/4	15-32	0.91	0.91	0.94
171PMTNS-4-6-4	1/4	3/8	1/4	5/8	0.93	1.21	0.97
171PMTNS-6-4	3/8	3/8	1/4	5/8	1.21	1.21	0.97
171PMTNS-6-4-4	3/8	1/4	1/4	5/8	1.21	0.93	0.97
171PMTNS-6-4-6	3/8	1/4	3/8	5/8	1.22	0.97	0.93
171PMTNS-6-6	1/2	3/8	3/8	5/8	1.21	1.27	0.97
171PMTNS-6-8	1/2	3/8	1/2	5/8	1.17	1.27	1.26
171PMTNS-8-4	1/2	1/2	1/4	7/8	1.28	1.27	1.06

172PMT Male Branch Tee Swivel

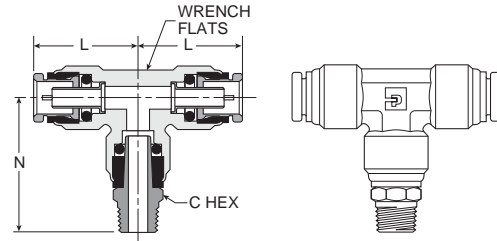

Part number	Tube size	Pipe thread (NPTF)	Wrench flats	C hex	L	N
172PMT-4-2	1/4	1/8	1/2	7/16	0.85	1.25
172PMT-4-4	1/4	1/4	1/2	9/16	0.85	1.43
172PMT-6-2	3/8	1/8	5/8	9/16	1.22	1.66
172PMT-6-4	3/8	1/4	5/8	5/8	1.22	1.83
172PMT-6-6	3/8	3/8	5/8	3/4	1.22	1.83
172PMT-8-4	1/2	1/4	7/8	5/8	1.27	1.73
172PMT-8-6	1/2	3/8	7/8	3/4	1.27	1.79
172PMT-8-8	1/2	1/2	7/8	7/8	1.27	1.97

171PMT Male Run Tee Swivel

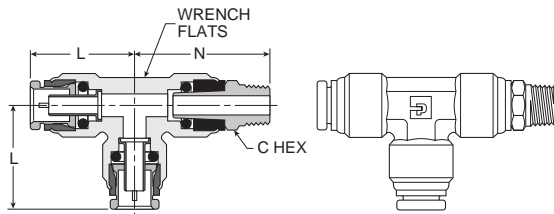

Part number	Tube size	Pipe thread (NPTF)	Wrench flats	L	N	N
171PMT-4-2	1/4	1/8	1/2	7/16	.85	1.25
171PMT-4-4	1/4	1/4	1/2	9/16	.85	1.48
171PMT-4-6	1/4	3/8	1/2	11/16	.85	1.43
171PMT-6-4	3/8	1/4	5/8	9/16	1.21	1.83
171PMT-6-6	3/8	3/8	5/8	11/16	1.21	1.83
171PMT-8-4	1/2	1/4	7/8	5/8	1.27	1.74
171PMT-8-6	1/2	3/8	7/8	3/4	1.27	1.83
171PMT-8-8	1/2	1/2	7/8	7/8	1.27	1.99

172PMTNS Male Branch Tee Non-Swivel

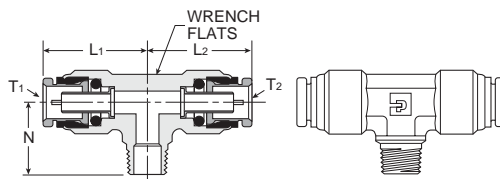

Part number	Tube 1 size	Tube 2 size	Pipe thread (NPTF)	Wrench flats	L1	L2	N
172PMTNS-4-2	1/4	1/4	1/8	1/2	0.91	0.91	0.78
172PMTNS-6-4	3/8	3/8	1/4	5/8	1.21	1.21	0.97
172PMTNS-6-4-4	3/8	1/4	1/4	5/8	1.21	.93	0.97
172PMTNS-6-6	3/8	3/8	3/8	5/8	1.21	1.21	0.97
172PMTNS-6-8	3/8	3/8	1/2	7/8	1.17	1.17	1.26
172PMTNS-8-6	1/2	1/2	3/8	7/8	1.28	1.28	1.06
172PMTNS-8-6-8	1/2	3/8	1/2	7/8	1.25	1.25	1.25
172PMTNS-8-8	1/2	1/2	1/2	7/8	1.34	1.25	1.25

Directair 2 & 4 Series

Viking Xtreme Lever Series

42 Lever / Pedal Series

MO Series

Safety



Manual / Mechanical Valves

Brass Poppet / Sliding Seal

Control Panel Products

Sensing



For inventory, lead times, and kit lookup, visit www.pdnplu.com

42 Lever / Pedal Series

Heavy duty lever

- Parallel mount handle
- Perpendicular mount handle

Heavy duty foot pedal

2 port sizes

- 1/4" port – 1.3 to 2.2 Cv
- 3/8" port – 1.3 to 2.9 Cv

2-position

- 4-way

3-position valves

- All ports blocked
- Center exhaust

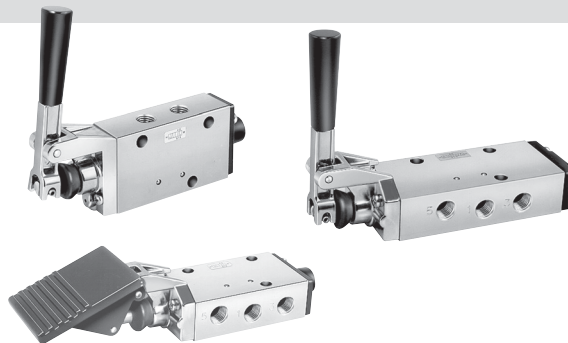

Operating information

Operating pressure: Vacuum to 150 PSI (710 mmHg to 1035 kPa)

Temperature range: 0°F to 140°F (-18°C to 60°C)

Lever Valve - 2-Position

	Symbol	Port size	Cv	Description	Valve type	Part number
		1/4"	2.2	Inline, parallel	2-position, spring return	422CS011K
		3/8"	2.9	Inline, parallel	2-position, spring return	422CS021K
		1/4"	2.2	Inline, parallel	2-position, detent	422CS011W
		3/8"	2.9	Inline, parallel	2-position, detent	422CS021W
		1/4"	2.2	Inline, perpendicular	2-position, spring return	422CR011K
		3/8"	2.9	Inline, perpendicular	2-position, spring return	422CR021K
		1/4"	2.2	Inline, perpendicular	2-position, detent	422CR011W
		3/8"	2.9	Inline, perpendicular	2-position, detent	422CR021W

Lever Valve - 3-Position

	Symbol	Port size	Cv	Description	Valve type	Part number
		1/4"	1.3	Inline, parallel	3-position, APB	422CS013W
		3/8"	1.3	Inline, parallel	3-position, APB	422CS023W
		1/4"	1.3	Inline, parallel	3-position, CE	422CS014W
		3/8"	1.3	Inline, parallel	3-position, CE	422CS024W
		1/4"	1.3	Inline, perpendicular	3-position, APB	422CR013W
		3/8"	1.3	Inline, perpendicular	3-position, APB	422CR023W
		1/4"	1.3	Inline, perpendicular	3-position, CE	422CR014W
		3/8"	1.3	Inline, perpendicular	3-position, CE	422CR024W

Foot Pedal Valve - 2-Position

	Symbol	Port size	Cv	Description	Valve type	Part number
		1/4"	2.2	Foot pedal	2-position, spring return	422CT011K
		3/8"	2.9	Foot pedal	2-position, spring return	422CT021K
				Foot pedal guard*		PS2043P

* This kit contains the valve mounting hardware.

CAUTION:

This valve shall not be used to actuate a punch press. Do not use this valve on punch presses or press brakes. See OSHA 1910.217.

Most popular.



For inventory, lead time, and kit lookup, visit www.pdnplu.com

42 Lever / Pedal Series

422 C R 0 1 1 K

Operator #14 End	
Lever Perpendicular (Inline Only)	R
Lever Parallel	S
Foot Pedal (2-Position, Spring Return, Inline Only)	T

Operator #12 End	
K	Spring Return (2-Position Only)
W	Detented

Style	
NPT	0

Function (4-Way)	
2-Position	
1	Single Pressure
3-Position*	
3	Single Pressure - All Ports Blocked
4	Single Pressure - Cyl. Ports to Exhaust

* Available Detented Only.

Port Size	
1	1/4"
2	3/8"

Valve body service kits

2-position valve	Single pressure	PS2038P
	Dual pressure	PS2039P
3-position valve	Single pressure	PS2041P

Kit includes: all soft seals and spool.

Most popular.



For inventory, lead times, and kit lookup, visit www.pdnplu.com

Directair 2 & 4 Series
Viking Xtreme Lever Series
42 Lever / Pedal Series
MO Series
Safety
Manual / Mechanical Valves
Brass Poppet / Sliding Seal
Control Panel Products
Sensing

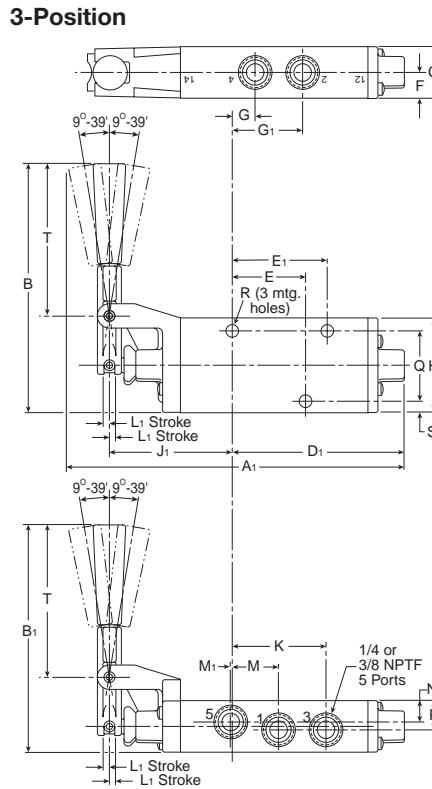
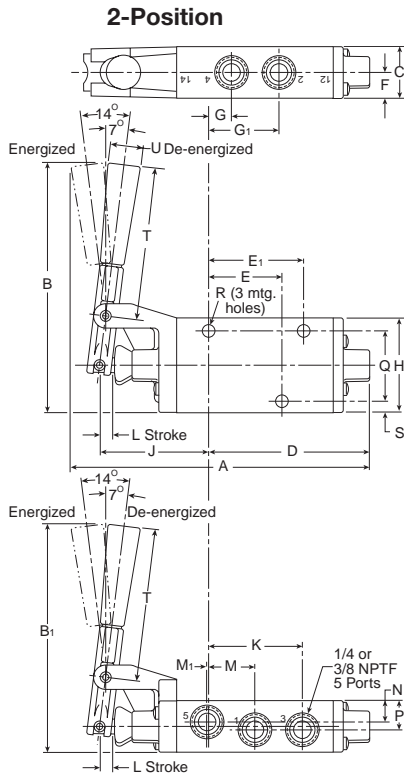

Lever Valve

A	A ₁	B	B ₁	C
6.70 (170)	7.58 (193)	5.55 (141)	5.05 (128)	1.15 (29)

D	D ₁	E	E ₁	F
3.59 (91)	3.83 (97)	1.58 (40)	2.06 (52)	.57 (14)

G NPT	G ₁ NPT	H
1/4" .51 (13) 3/8" .55 (14)	1/4" 1.56 (40) 3/8" 1.51 (38)	2.13 (54)

J	J ₁	K NPT	L
2.44 (62)	2.80 (71)	1/4" 2.08 (53) 3/8" 2.13 (54)	.25 (6)

L ₁	M	M ₁ NPT	N
.18 (5)	1.03 (36)	1/4" .02 (.5) 3/8" .06 (2)	.50 (13)

P	Q	R	S	T
.65 (17)	1.58 (40)	.33 (8)	.27 (7)	3.42 (87)

U Dia

.75
(19)

Inches (mm)

Foot Pedal Valve

A	B	B ₁	C	D
8.64 (220)	2.18 (55)	1.03 (26)	1.15 (29)	3.59 (91)

E	E ₁	F	G NPT
1.58 (40)	2.06 (52)	.57 (14)	1/4" .51 (13) 3/8" .55 (14)

G ₁ NPT	H	H ₁	J
1/4" 1.56 (40) 3/8" 1.51 (38)	2.13 (54)	2.50 (64)	2.32 (59)

K NPT	L	M
1/4" 2.08 (53) 3/8" 2.13 (54)	.60 (15)	1.03 (26)

M ₁ NPT	N	P	Q
1/4" .02 (.5) 3/8" .06 (2)	.50 (13)	.65 (17)	1.58 (40)

R	S	T	U
.33 (8)	.27 (7)	3.00 (76)	.48 (11)

Inches (mm)

Foot Valve Guard: PS2043P*

A	A ₁	B	B ₁	C
4.50 (114)	.75 (19)	10.50 (267)	1.25 (32)	.48 (11)

D	E	E ₁	F	F ₁
6.00 (152)	7.13 (181)	.50 (13)	13.00 (330)	8.38 (213)

Inches (mm)

* This kit contains the valve mounting hardware.

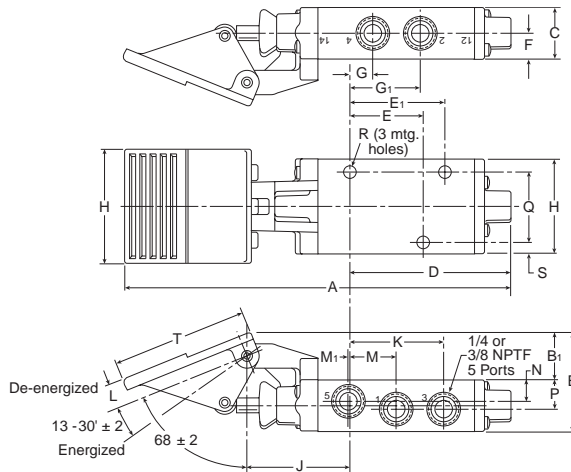

CAUTION:

This valve shall not be used to actuate a punch press. Do not use this valve on punch presses or press brakes. See OSHA 1910.217.

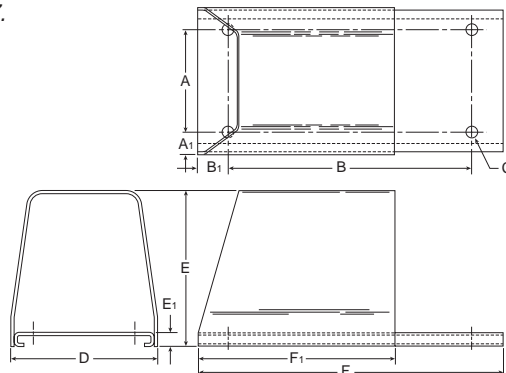

For inventory, lead time, and kit lookup, visit www.pdnplu.com

Directair 2
& 4 Series

Viking Xtreme
Lever Series

42 Lever/
Pedal Series

MO Series

Safety



Manual / Mechanical
Valves

Brass Poppet /
Sliding Seal

Control Panel
Products

Sensing

Features

MO Series

MO Series

- 1/4" to 3/4" NPTF ports
- Standard operators listed. Consult factor for variations in orientation
- Standard 2 position 3-way and 4-way valves listed. Consult factory for 2-way and 3 position valves
- Corrosion resistant bronze body
- High flow brass spacers position o-ring, permit reverse piping and vacuum service
- Specially compounded o-rings suitable for non-lube air service and low pressure oil service
- Floating stem of hard chrome plated stainless steel; no metal to metal contact
- Closed at crossover design for air savings
- Piped exhaust convenient for muffling
- Interchangeable operators
- Interchangeable end sections
- Service without disturbing plumbing
- Dual mounting brackets on most models

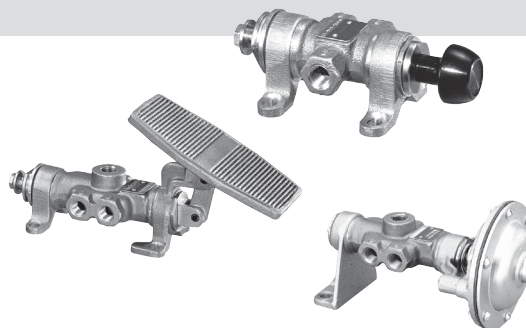

Flow Cv ratings

Valve type	Port size	Port 1 to 2	Port 1 to 3	Port 2 to 3	Port 2 to 4	Port 3 to 4
3-way 2-position	1/4	2.4	—	2.4	—	—
	3/8	3.2	—	3.4	—	—
	1/2	5.0	—	5.1	—	—
4-way 2-position	1/4	2.4	2.4	—	2.0	2.2
	3/8	3.4	3.2	—	3.0	3.1
	1/2	5.2	5.3	—	4.7	4.7
	3/4	8.7	9.2	—	7.9	8.0

Flow Cv

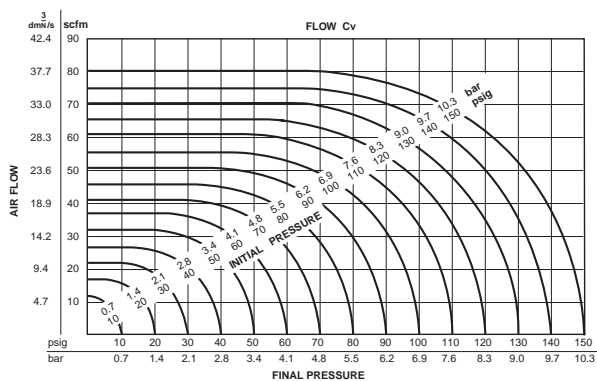

Flow capacities

The capacity curves shown in the chart are for a theoretical valve having a Cv = 1.0 for air at standard conditions.

Flow rating determined in accordance with NFPA recommended standard NFPA/T3.21.3 - 1974.

Operating information

Pressure limitations
Knob (manual and spring return) and palm operators (manual and spring return)

Media	Port size	PSI (kPa)	
		3-way	4-way
Air and Hydraulic	1/4	200 (1380)	180 (1240)
	3/8	175 (1210)	170 (1170)
	1/2	160 (1100)	150 (1030)
	3/4	150 (1030)	150 (1030)
Vacuum	All	Within 1" Hg of perfect	
Other	Consult factory		

Pressure limitations
Knob (detent), lever, pedal, treadle, clevis, cam air operated diaphragm and cylinder

Media	Port size	PSI (kPa)	
		3-way	4-way
Air and Hydraulic	1/4	225 (1550)	225 (1550)
	3/8	225 (1550)	225 (1550)
	1/2	215 (1480)	215 (1480)
	3/4	200 (1380)	200 (1380)
Vacuum	All	Within 1" Hg of perfect	
Other	Consult factory		

Temperature range: -15°F to 200°F (-26° to 93°C)

Lubrication: For best results and service life use clean, moisture free lubricated air.

Material specifications

Body	High pressure valve bronze
Knobs and palm buttons	Anodized aluminum
Operators	Iron castings; steel rod, bar and tube, and plated for corrosion resistance
O-rings	Buna-N and impregnated with Molybdenum Disulfide
Spacers and end bearings	Brass bar stock
Springs	high quality steel and plated for corrosion resistance
Stem	Stainless steel and hard chrome plated

Warnings

- ⚠ Install guards on all hand operated valves if accidental operation can cause personal injury.
- ⚠ Foot operated valves must be protected against inadvertent operation that can cause serious bodily injury. Use of a guard is strongly recommended as it will reduce the likelihood of inadvertent operation.



For inventory, lead times, and kit lookup, visit www.pdnplu.com

Directair 2 & 4 Series

Viking Xtreme Lever Series

422 Lever / Pedal Series

MO Series

Safety



Manual / Mechanical Valves

Brass Poppet / Sliding Seal

Control Panel Products

Sensing

MO Series Air Pilot, Manual & Mechanically Actuated Valves

3-way and 4-way knob operated	Description	Part number 1/4 NPT	Part number 3/8 NPT	Part number 1/2 NPT	Part number 3/4 NPT
	3-way, detent ball, foot bracket	M05422448	M05432448	M05442448	M05462448
	3-way, detent ball, panel mount with nut	M05822451	M05832451	M05842451	M05862451
	3-way, N.C., manual, foot bracket	M08521848	M08531848	M08541848	M08561848
	3-way, N.C., manual, panel nut	M08521851	M08531851	M08541851	M08561851
	3-way, N.C., pull to operate, spring return, foot bracket	M09721848	M09731848	M09741848	M09761848
	3-way, N.C., pull to operate, spring return, panel mount with nut	M06421851	M06431851	M06441851	M06461851
	3-way, N.C., push to operate, spring return, foot bracket	M09821848	M09831848	M09841848	M09861848
	3-way, N.C., push to operate, spring return, panel mount with nut	M06521851	M06531851	M06541851	M06561851
	4-way, detent ball, foot bracket	M05425448	M05435448	M05445448	M05465448
	4-way, detent ball, panel mount with nut	M05825451	M05835451	M05845451	M05865451
	4-way, manual, foot bracket	M08524648	M08534648	M08544648	M08564648
	4-way, manual, panel nut	M08524651	M08534651	M08544651	M08564651
	4-way, pull to operate, spring return, foot bracket	M09724648	M09734648	M09744648	M09764648
	4-way, pull to operate, spring return, panel mount with nut	M06424651	M06434651	M06444651	M06464651
	4-way, push to operate, spring return, foot bracket	M09824648	M09834648	M09844648	M09864648
	4-way, push to operate, spring return, panel mount with nut	M06524651	M06534651	M06544651	M06564651
3-way and 4-way palm button operated					
	3-way, N.C., pull palm button to operate, spring return, panel mount with nut	M06421859	M06431859	M06441859	M06461859
	3-way, N.C., push palm button to operate, spring return, panel mount with nut	M06521859	M06531859	M06541859	M06561859
	4-way, pull palm button to operate, spring return panel mount with nut	M06424659	M06434659	M06444659	M06464659
	4-way, push palm button to operate, spring return, panel mount with nut	M06524659	M06534659	M06544659	M06564659
3-way and 4-way lever operated					
	3-way, detent ball, foot bracket	M05422443	M05432443	M05442443	M05462443
	3-way, manual, foot bracket	M08521843	M08531843	M08541843	M08561843
	3-way, N.C., pull lever to operate, spring return, foot bracket	M09621843	M09631843	M09641843	M09661843
	3-way, N.C., push lever to operate, spring return, foot bracket	M09521843	M09531843	M09541843	M09561843
	4-way, detent ball, foot bracket	M05425443	M05435443	M05445443	M05465443
	4-way, manual, foot bracket	M08524643	M08534643	M08544643	M08564643
	4-way, pull lever to operate, spring return, foot bracket	M09624643	M09634643	M09644643	M09664643
	4-way, push lever to operate, spring return, foot bracket	M09524643	M09534643	M09544643	M09564643

Most popular.



For inventory, lead time, and kit lookup, visit www.pdnplu.com

Directair 2
& 4 Series

Viking Xtreme
Lever Series

42 Lever/
Pedal Series

MO Series

Safety



Manual / Mechanical
Valves

Brass Poppet /
Sliding Seal









Control Panel
Products

Sensing

Common Part Numbers













MO Series

MO Series Air Pilot, Manual & Mechanically Actuated Valves

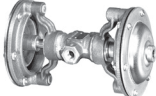
3-way and 4-way, foot operated: treadle / pedal type	Description	Part number 1/4 NPT	Part number 3/8 NPT	Part number 1/2 NPT	Part number 3/4 NPT
	 3-way, treadle operated, detent ball, foot bracket	M05422488	M05432488	M05442488	—
	 3-way, treadle operated, manual return, foot bracket	M08521888	M08531888	M08541888	—
	 3-way, N.C., spring return, pedal operated, foot bracket	M06221840	M06231840	M06241840	—
	 4-way, treadle operated, detent ball, foot bracket	M05425488	M05435488	M05445488	—
	 4-way, treadle operated, manual return, foot bracket	M08524688	M08534688	M08544688	—
	 4-way, spring return, pedal operated, foot bracket	M06224640	M06234640	M06244640	—









CAUTION: This valve shall not be used to actuate a punch press. Do not use this valve on punch presses or press brakes. See OSHA 1910.217.

3-way and 4-way air operated : diaphragm or cylinder

	 3-way, N.C., single air diaphragm, air signal to actuate, spring return foot bracket	M08421830	M08431830	M08441830	—
	 3-way, single air cylinder signal to actuate, spring return foot bracket	M08521826	M08531826	M08541826	M08561826
	 3-way, double air diaphragm	M03321833	M03331833	M03341833	—
	 3-way, double air cylinder foot bracket	M01921819	M01931819	M01941819	M01961819
	 4-way, single air diaphragm, air signal to actuate, spring return foot bracket	M08424630	M08434630	M08444630	—
	 4-way, single air cylinder signal to actuate, spring return foot bracket	M08524626	M08534626	M08544626	M08564626
	 4-way, double air diaphragm	M03324633	M03334633	M03344633	—
	 4-way, double air cylinder foot bracket	M01924619	M01934619	M01944619	M01964619

Note: diaphragm operators : pilot signal pressures from 20 to 60 psi. Cylinder operators : pilot signal pressures from 20 to 250 psi.

3-way and 4-way clevis operated

	 3-way, manual, foot bracket	M08521805	M08531805	M08541805	M08561805
	 3-way, N.C., pull to operate, spring return foot bracket	M09621805	M09631805	M09641805	M09661805
	 3-way, N.C., push to operate, spring return, foot bracket	M09521805	M09531805	M09541805	M09561805
	 4-way, manual, foot bracket	M08524605	M08534605	M08544605	M08564605
	 4-way, pull clevis to operate, spring return, foot bracket	M09624605	M09634605	M09644605	M09664605
	 4-way, push clevis to operate, spring return, foot bracket	M09524605	M09534605	M09544605	M09564605

3-way and 4-way cam operated

	 3-way, N.C., spring return, cam operated, foot bracket	M09521803	M09531803	M09541803	M09561803
	 4-way, spring return, cam operated, foot bracket	M09524603	M09534603	M09544603	M09564603

 Most popular.



For inventory, lead times, and kit lookup, visit www.pdnplu.com

Directair 2 & 4 Series

Viking Xtreme Lever Series

42 Lever / Pedal Series

MO Series

Safety



Manual / Mechanical Valves

Brass Poppet / Sliding Seal

Control Panel Products

Sensing

Ordering Information

MO Series

MO Valve: 1/4", 3/8", 1/2" Port Size

MO 85 3 18 48

Valve Series	
Basic Series	MO

Left End Section	
Double Cylinder	19
Double Air Diaphragm	33
Ball Detent, Small Bracket	54
Ball Detent, Panel Mounted	58
Direct Acting Spring Return, Less Bracket (Push Lever)	62
Reverse Acting Spring Return, Less Bracket (Pull Lever)	63
Light Spring Return Direct Acting, Less Bracket (Pull Knob)	64
Light Spring Return Reverse Acting, Less Bracket (Push Knob)	65
Stem Stop, Large Bracket	84
Stem Stop, Small Bracket	85
Direct Acting Spring Return, Small Bracket (Push Lever)	95
Reverse Acting Spring Return, Small Bracket (Pull Lever)	96
Light Spring Return Direct Acting, Small Bracket (Pull Knob)	97
Light Spring Return Reverse Acting, Small Bracket (Push Knob)	98

Pipe Size	
NPT	Port Size
1/4	2
3/8	3
1/2	4

Operating End Section: Right End	
03	Cam Follower
05	Clevis, Small Bracket
19	Double Cylinder
26	Single Cylinder
30	Single Diaphragm, Std. Spring
33	Double Diaphragm
40	Pedal
43	Lever, Mounting Feet
48	Knob, Small Bracket
51	Knob, Panel Mounted
59	Palm Button, Panel Mounted
88	Treadle
99	Palm Button

Body / Function	
18	3-Way
24*	3-Way, 2-Position Detent
46	4-Way
54*	4-Way, 2-Position Detent

* At least one end section must be coded 54.

MO Valve: 3/4" Port Size

MO 85 6 18 48

Valve Series	
Basic Series	MO

Left End Section	
Double Cylinder	19
Ball Detent, Small Bracket	54
Ball Detent, Panel Mounted	58
Direct Acting Spring Return, Less Bracket (Push Lever)	62
Reverse Acting Spring Return, Less Bracket (Pull Lever)	63
Light Spring Return Direct Acting, Less Bracket (Pull Knob)	64
Light Spring Return Reverse Acting, Less Bracket (Push Knob)	65
Stem Stop, Small Bracket	85
Direct Acting Spring Return, Small Bracket (Push Lever)	95
Reverse Acting Spring Return, Small Bracket (Pull Lever)	96
Light Spring Return Direct Acting, Small Bracket (Pull Knob)	97
Light Spring Return Reverse Acting, Small Bracket (Push Knob)	98

Pipe Size	
NPT	Port Size
3/4	6

Operating End Section: Right End	
03	Cam Follower
05	Clevis, Small Bracket
19	Double Cylinder
26	Single Cylinder
43	Lever, Mounting Feet
48	Knob, Small Bracket
51	Knob, Panel Mounted
59	Palm Button, Panel Mounted
99	Palm Button

Body / Function	
18	3-Way
24*	3-Way, 2-Position Detent
46	4-Way
54*	4-Way, 2-Position Detent

* At least one end section must be coded 54.



CAUTION:

Be sure to order end sections that are functionally effective with each other and with the body section selected. Model number combinations are possible which may not operate.



For inventory, lead time, and kit lookup, visit www.pdnplu.com

Directair 2 & 4 Series

Viking Xtreme Lever Series

42 Lever / Pedal Series

MO Series

Safety



Manual / Mechanical Valves

Brass Poppet / Sliding Seal

Control Panel Products

Sensing

Accessories

MO Series

**Pedal Guard
(Fits all pedal operated valves)**

Description	Model number
Guard with door	M232001
Guard without door	M232002
Guard with door for 1/4 and 3/8 valve	M232003*
Guard without door for 1/4 and 3/8 valve	M232004*
Guard with door for 1/2 and 3/4	M232005*
Guard without door for 1/2 and 3/4	M232006*

* Includes mounting hardware.

CAUTION:

Foot valves utilizing this guard shall not be used to actuate a punch press.
Do not use this valve on punch presses or press brakes.
See OSHA 1910.217.

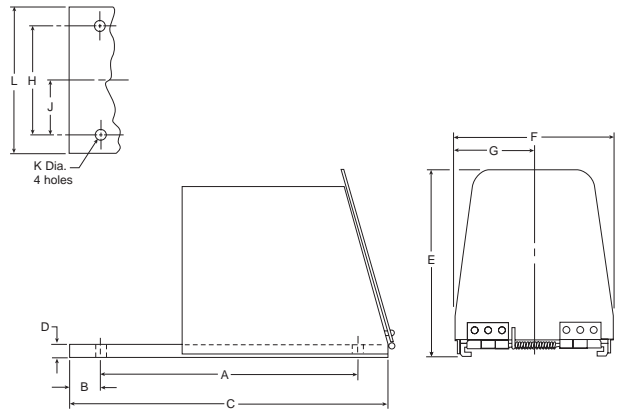

Dimensions

A	B	C	D	E	F	G
10.50	1.25	13.00	.50	7.38	6.36	3.18
266.7	31.8	330.2	12.7	187.4	161.5	80.8
H	J	K	L			
4.50	2.25	.44	6.00			
114.3	57.2	11.2	152.4			

MO valve 9 digit part number dissection

The MO Valve Series has with wide variety of operating and return ends which can be ordered either on the left or right hand side of the valve body. Common part numbers on the previous pages can be ordered with the left and right hand ends swapped. Swapping operator and return end sections does not change the spool function, but can reverse the

expected function of the valve. For example, a 3-way, normally closed, "NC", spring return valve will become a 3-way normally open, "NO", valve when the operator and return section is swapped. There are other non-cataloged options available and this part number dissection will enable you to discuss your valve part number with the factory for options.

3-way

Series name	Left end	Port size	Body function	Right end
MO	XX	X	XX	XX

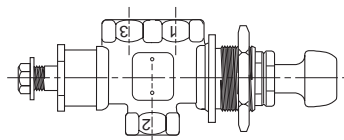

Left End Section in relation to port #2 ← → Right End Section in relation to port #2

4-way

Series name	Left end	Port size	Body function	Right end
MO	XX	X	XX	XX

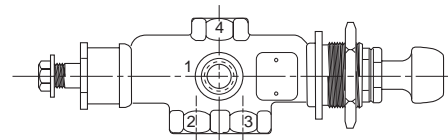

Left End Section in relation to port #2 ← → Right End Section in relation to port #3

Most popular.



For inventory, lead times, and kit lookup, visit www.pdnplu.com

Body Sections

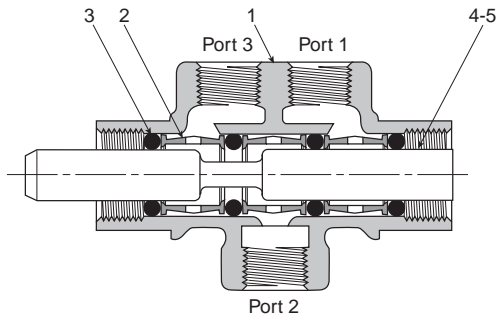

M032*18
Standard 3-Way
M032*24
2-Position Detent 3-Way

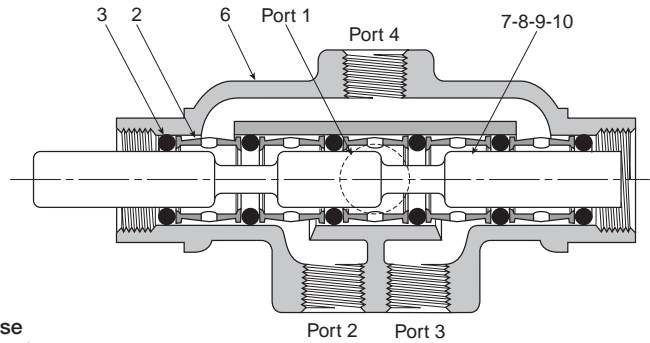

M032*46
Standard 4-Way
M032*54
2-Position Detent 4-Way

Port Size	Use No. *
1/4	2
3/8	3
1/2	4
3/4	6

Item No.	Part number				Description
	1/4"	3/8"	1/2"	3/4"	
1	M053007	M053019	M053030	M053038	Body – 3-Way
2	M313004	M313011	M313013	M313017	Spacer (2-3-5)
3	H13466	H13588	H13580	H13584	O-Ring (3-4-6)
4	M373014	M373060	M373102	M373142	Stem – 3-Way
5	M373020	M373064	M373103	M373146	Stem – 3-Way 2-Pos. Detent
6	M053003	M053020	M053033	M053039	Body – 4-Way
7	M373033	M373074	M373116	M373156	Stem – 4-Way
8	M373039	M373076	M373118	—	Stem – 4-Way 2-Pos. Detent

NOTE: () denotes quantity required when more than one.

Service Kits

(Field service instructions)

Description (For all 3 & 4-way valves)	1/4	3/8	1/2	3/4
Manual & mechanical operators	M242001	M242002	M242003	M242004
Cylinder (single, double & double-acting)	M242006	M242007	M242008	M242009
Diaphragm (single & double)	M242011	M242012	M242013	M242014

Replacement Knobs & Palm Buttons



Knob & Adapter Kit Palm Button & Adapter Kit

Description	1/4" & 3/8"	1/2"	3/4"
Knob & Adapter Kit	M122001	M122002	M122003
Palm Button & Adapter Kit	M122004	M122005	M122006

Hex Drive Pipe Plugs

Port size	1/4"	3/8"	1/2"	3/4"
Part number	K21R02025L	K21R02037L	K21R02050L	K21R02075L



For inventory, lead time, and kit lookup, visit www.pdnplu.com

Directair 2 & 4 Series
 Viking Xtreme Lever Series
 42 Lever / Pedal Series
 MO Series
 Safety
 Manual / Mechanical Valves
 Brass Poppet / Sliding Seal
 Control Panel Products
 Sensing

Technical Data

Manual & Mechanical Operators

Directair 2
& 4 Series

Viking Xtreme
Lever Series

42 Lever /
Pedal Series

MO Series

Safety



Manual / Mechanical
Valves

Brass Poppet /
Sliding Seal

Control Panel
Products

Sensing

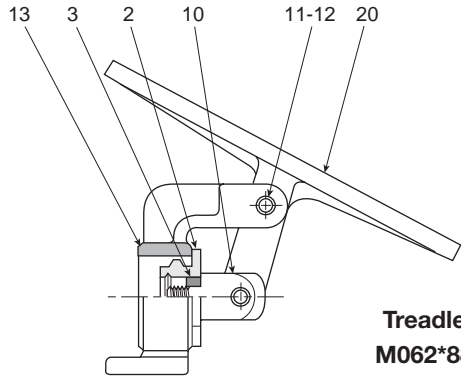

**Treadle
M062*88**

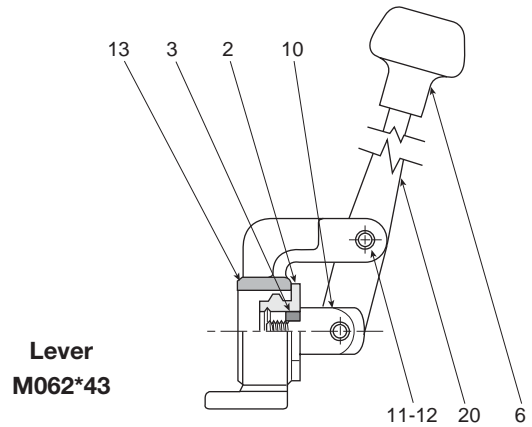

**Lever
M062*43**

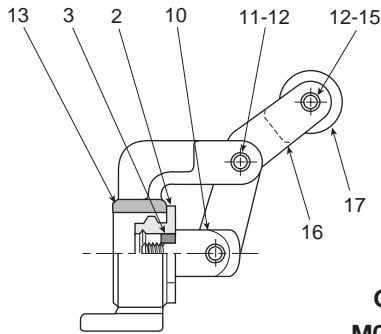

**Cam
M062*03**

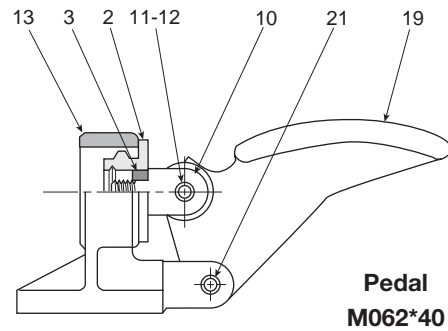

**Pedal
M062*40**

Port Size	Use No. *
1/4	2
3/8	3
1/2	4
3/4	6

Item No.	Part number				Description
	1/4"	3/8"	1/2"	3/4"	
2	M103012	M103047	M103066	M103108	End Bearing
3	H17705	H17705	H17706	H17408	Lockwasher
6	H05028	H05028	H05028	H05028	Knob
10	M133003	M133003	M133012	M133018	Clevis
11	H07229	H07229	M333013	M333013	Pivot Pin (2)
12	—	—	H08903	H08903	Retaining Ring (4)
13	M073009	M073022	M073033	M073042	Bracket
14	M273022	M273022	M273023	M273024	Lever
15	—	H07230	M333016	M333016	Roller Trunnion
16	M273002	M273002	M273006	M273007	Cam Arm
17	M443003	M443003	M443002	M443002	Roller
19	M323005	M323005	M323006	M323007	Pedal
20	M553004	M553004	M553005	—	Treadle
21	H07229	H07229	M333013	M333014	Pivot Pin

NOTE: () denotes quantity required when more than one.



For inventory, lead times, and kit lookup, visit www.pdnplu.com

Manual & Mechanical Operators

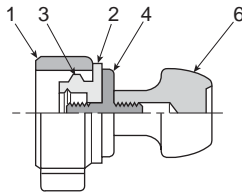

Knob
M062*48

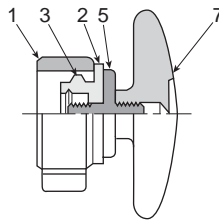

Palm Button
M062*99

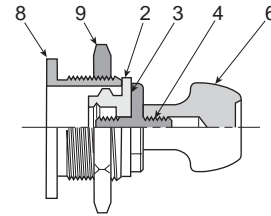

Panel Mounted Knob
M062*51

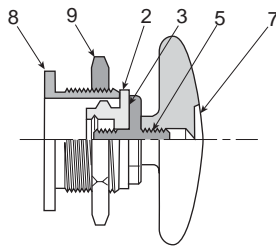

Panel Mounted Palm Button
M062*59

Port Size	Use No. *
1/4	2
3/8	3
1/2	4
3/4	6

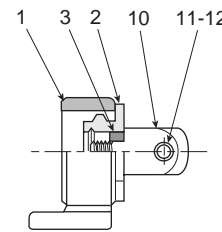

Clevis
M062*05

Item No.	Part number				Description
	1/4"	3/8"	1/2"	3/4"	
1	M073016	M073026	M073037	M073046	Bracket
2	M103012	M103047	M103066	M103108	End Bearing
3	H17705	H17705	H17706	H17408	Lockwasher
4	M013011	M013011	M013012	M013013	Knob Adapter
5	M013011	M013011	M013012	M013013	Palm Knob Adapter
6	H05028	H05028	H05028	H05028	Knob
7	H05029	H05029	H05029	H05029	Palm Button
8	M013014	M013015	M013016	M013017	Panel Adapter
9	M303005	M303006	M303007	M303008	Jam Nut
10	M133003	M133003	M133012	M133018	Clevis
11	H07229	H07229	M333013	M333013	Pivot Pin (2)
12	—	—	H08903	H08903	Retaining Ring (4)

NOTE: () denotes quantity required when more than one.



For inventory, lead time, and kit lookup, visit www.pdnplu.com

Directair 2
& 4 Series

Viking Xtreme
Lever Series

42 Lever/
Pedal Series

MO Series

Safety



Manual / Mechanical
Valves

Brass Poppet /
Sliding Seal

Control Panel
Products

Sensing

Technical Data

MO Series

Pneumatic Operators

Directair 2
& 4 Series

Viking Xtreme
Lever Series

42 Lever /
Pedal Series

MO Series

Safety



Manual / Mechanical
Valves

Brass Poppet /
Sliding Seal

Control Panel
Products

Sensing

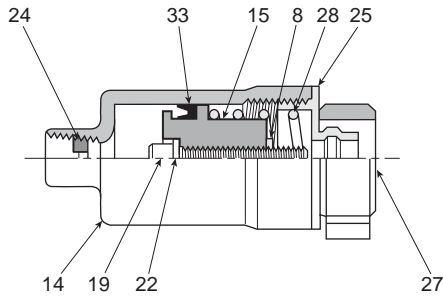

**Single Cylinder
M062*26**

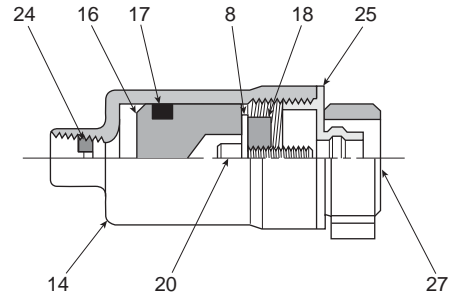

**Double Cylinder
M062*19**

Port Size	Use No. *
1/4	2
3/8	3
1/2	4
3/4	6

Item No.	Part number				Description
	1/4"	3/8"	1/2"	3/4"	
8	H17705	H17705	H17706	H17408	Lockwasher
14	M243028	M243028	M243028	M243036	Housing
15	M343019	M343019	M343018	M343027	Piston – Single Act.
16	M343022	M343022	M343022	M343028	Piston – Double Cyl.
17	H14515	H14515	H14515	H14520	Packer
18	M013005	M013005	M013007	M013009	Adapter
19	H10121	H10121	H10147	H10219	Screw – Single Act.
20	H10117	H10117	H10145	H10215	Screw – Double Act.
22	H17514	H17514	H17519	H17524	Lockwasher
24	M363002	M363002	M363002	M363002	Restrictor
25	M383007	M383011	M383018	M383029	Retainer
27	M073016	M073026	M073037	M073046	Bracket
28	M493015	M493015	M493015	M493020	Spring
33	H22232	H22232	H22232	H14520	Packer

NOTE: () denotes quantity required when more than one.



For inventory, lead times, and kit lookup, visit www.pdnplu.com

Pneumatic Operators

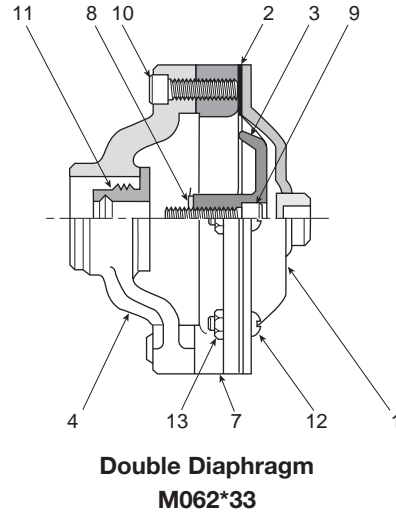
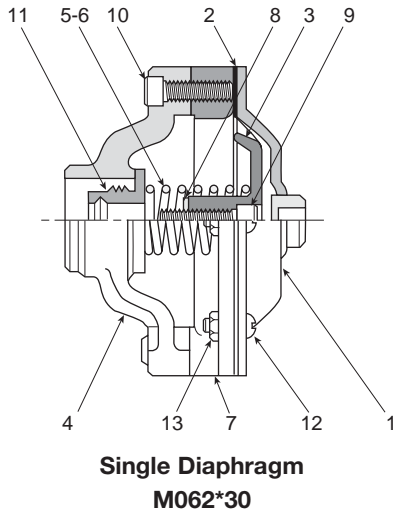

Port Size	Use No. *
1/4	2
3/8	3
1/2	4
3/4	6

Item No.	Part number				Description
	1/4"	3/8"	1/2"	3/4"	
1	M163005	M163005	M163005	M163012	Cover
2	M193002	M193002	M193002	M193005	Diaphragm
3	M343038	M343038	M343032	M343039	Piston
4	M573004	M573003	M573001	M573011	Yoke
5	M493024	M493024	M493010	M493023	Spring
6	M493022	M493022	M493009	—	Spring (Inst. Air)
7	M423002	M423002	M423002	M423004	Ring
8	H17705	H17705	H17706	H17408	Lockwasher
9	H10119	H10119	H10145	H10217	Screw
10	H10115	H10115	H10115	H10115	Screw (2)
11	M103012	M103047	M103066	M103108	End Bearing
12	H11333	H11333	H11333	H11333	Screw (6)
13	H06416	H06416	H06416	H06416	Nut (6)

NOTE: () denotes quantity required when more than one.

Directair 2 & 4 Series
 Viking Xtreme Lever Series
 42 Lever / Pedal Series
 MO Series
 Safety
 Manual / Mechanical Valves
 Brass Poppet / Sliding Seal
 Control Panel Products
 Sensing



For inventory, lead time, and kit lookup, visit www.pdnplu.com

End Sections

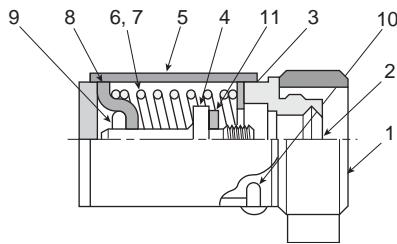

Direct Acting Spring Return with Bracket
M062*95 Push Lever
M062*97 Pull Knob

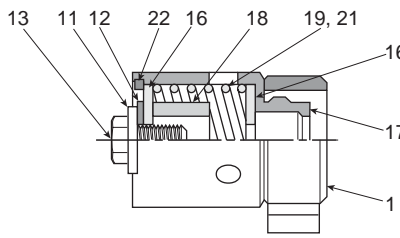

Spring Centered Neutral Standard Spring
M062*74 Standard Spring
M062*78 Heavy Spring

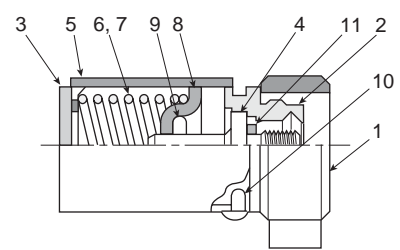

Reverse Acting Spring Return with Bracket
M062*96 Pull Lever
M062*98 Push Knob

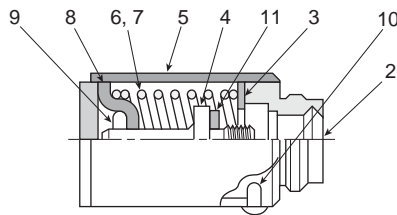

Direct Acting Spring Return Less Bracket
M062*62 Push Lever
M062*64 Pull Knob

Port Size	Use No. *
1/4	2
3/8	3
1/2	4
3/4	6

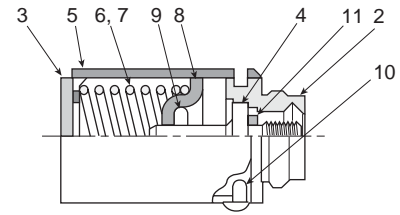

Reverse Acting Spring Return Less Bracket
M062*63 Pull Lever
M062*65 Push Knob

Item No.	Part number				Description
	1/4"	3/8"	1/2"	3/4"	
1	M073016	M073026	M073037	M073046	Bracket
2	M103111	M103112	M103113	M103114	End Bearing
3	M413015	M413015	M413016	M413017	Spring Retainer Washer
4	M523009	M523009	M523010	M523011	Stem Stop – Guide
5	M243043	M243043	M243044	M243045	Spring Housing
6	M493037	M493037	M493027	M493026	Spring – Knob Oper.
7	M493038	M493038	M493011	M493012	Spring – Other Oper.
8	M383032	M383032	M383033	M383034	Spring Retainer
9	H07254	H07254	H07270	H07271	Roll Pin
10	H11215	H11215	H11216	H11217	Screw
11	H17705	H17705	H17706	H17408	Lockwasher
12	M563002	M563002	M563006	M563014	Stem Stop
13	H09626	H09626	H09645	H09706	Stem Stop Screw
16	M563007	M563009	M563008	M563016	Washer
17	M243008	M243019	M243027	M243032	Spring Housing
18	M083003	M083004	M083005	M083008	Spacer
19	M493008	M493008	M493008	M493014	Spring
21	M493006	M493006	M493006	M493007	Spring – Dbl. Act. Cyl.
22	H09025	H09025	H09025	H09012	Retainer Ring

NOTE: () denotes quantity required when more than one.



For inventory, lead times, and kit lookup, visit www.pdnplu.com

Directair 2 & 4 Series
 Viking Xtreme Lever Series
 42 Lever / Pedal Series
 MO Series
 Safety
 Manual / Mechanical Valves
 Brass Poppet / Sliding Seal
 Control Panel Products
 Sensing

End Sections

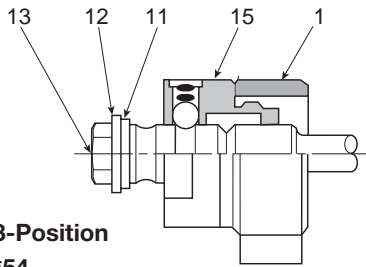

**Ball Detent, 3-Position
M062*54**

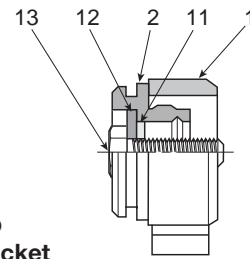

**Stem Stop
with Small Bracket
M062*85**

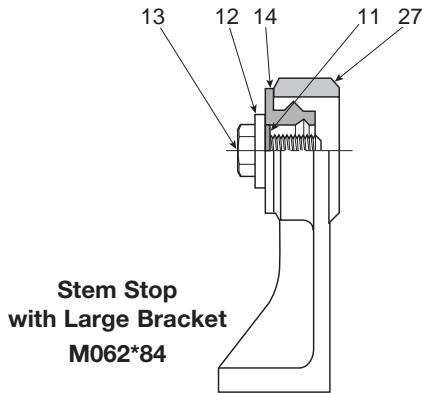

**Stem Stop
with Large Bracket
M062*84**

Port Size	Use No. *
1/4	2
3/8	3
1/2	4
3/4	6

Item No.	Part number				Description
	1/4"	3/8"	1/2"	3/4"	
1	M073016	M073026	M073037	M073046	Bracket
2	M103111	M103112	M103113	M103114	End Bearing
11	H17705	H17705	H17706	H17408	Lockwasher
12	M563002	M563002	M563006	M563014	Stem Stop
13	H09626	H09626	H09645	H09706	Stem Stop Screw
14	M103012	M103047	M103066	M103108	End Bearing – Plain
15	M012001	M012002	M012003	M012005	Ball Detent Assembly
27	M073006	M073017	M073028	—	Large Bracket

NOTE: () denotes quantity required when more than one.

Directair 2
& 4 Series

Viking Xtreme
Lever Series

42 Lever/
Pedal Series

MO Series

Safety



Manual / Mechanical
Valves

Brass Poppet /
Sliding Seal

Control Panel
Products

Sensing



For inventory, lead time, and kit lookup, visit www.pdnplu.com

Dimensional Data

Knob Operated, 2-Position Detent, Ball Detent

M054 Ball Detent, Small Bracket & M058 Ball Detent, Panel Mounted

3-Way

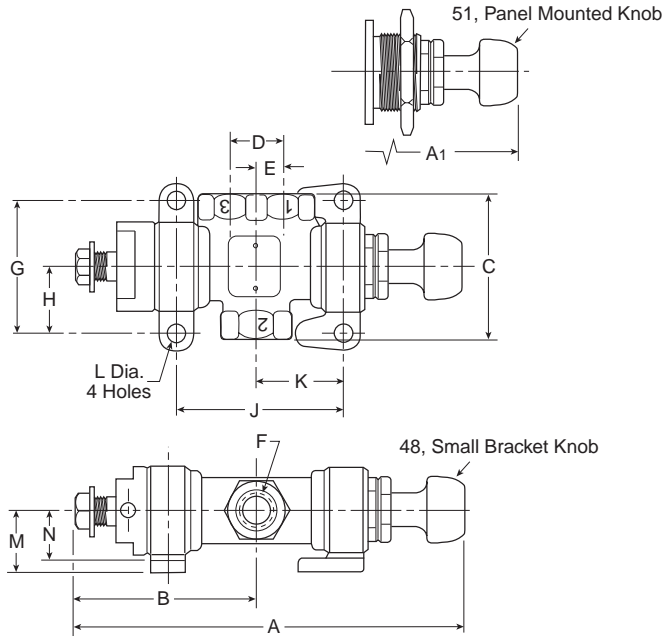

	1/4	3/8	1/2	3/4
A	6.57 (166.9)	7.30 (185.4)	8.56 (217.4)	10.40 (264.2)
A1	6.57 (166.9)	7.30 (185.4)	8.56 (217.4)	10.40 (264.2)
B	3.25 (82.6)	3.66 (93.0)	4.39 (111.5)	5.41 (137.4)
C	2.38 (60.4)	2.62 (66.6)	3.00 (76.2)	3.62 (92.0)
D	.94 (23.9)	1.06 (26.9)	1.25 (31.8)	1.62 (41.2)
E	.47 (11.9)	.53 (13.5)	.62 (15.8)	.81 (20.6)
F	1/4" Pipe	3/8" Pipe	1/2" Pipe	3/4" Pipe
G	2.25 (57.2)	2.38 (60.4)	2.62 (66.6)	3.25 (82.6)
H	1.12 (28.4)	1.19 (30.2)	1.31 (33.3)	1.62 (41.2)
J	2.63 (66.8)	3.13 (79.5)	3.72 (94.5)	4.56 (115.8)
K	1.31 (33.3)	1.56 (39.6)	1.86 (47.2)	2.28 (57.9)
L	.34 (8.6)	.34 (8.6)	.41 (10.4)	.41 (10.4)
M	1.12 (28.4)	1.12 (28.4)	1.25 (31.8)	1.56 (39.6)
N	.25 (6.4)	.25 (6.4)	.31 (7.9)	.31 (7.9)

Inches (mm)

M054 Ball Detent, Small Bracket & M058 Ball Detent, Panel Mounted

4-Way

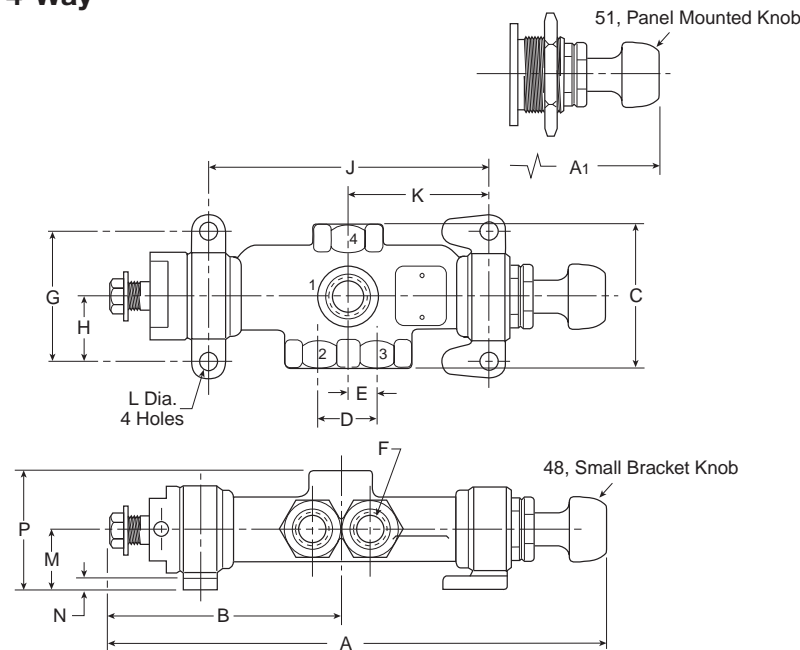

	1/4	3/8	1/2	3/4
A	8.02 (203.7)	9.13 (231.9)	11.17 (283.7)	13.10 (332.7)
A1	8.02 (203.7)	9.13 (231.9)	11.17 (283.7)	13.10 (332.7)
B	4.00 (101.6)	4.57 (116.1)	5.44 (138.2)	6.76 (171.7)
C	2.38 (60.4)	2.62 (66.6)	3.00 (76.2)	3.62 (92.0)
D	.94 (23.9)	1.06 (26.9)	1.25 (31.8)	1.62 (41.2)
E	.47 (11.9)	.53 (13.5)	.62 (15.8)	.81 (20.6)
F	1/4" Pipe	3/8" Pipe	1/2" Pipe	3/4" Pipe
G	2.25 (57.2)	2.38 (60.4)	2.62 (66.6)	3.25 (82.6)
H	1.12 (28.4)	1.19 (30.2)	1.31 (33.3)	1.62 (41.2)
J	4.14 (105.2)	4.98 (126.5)	5.85 (148.6)	7.39 (187.7)
K	2.07 (52.6)	2.49 (63.2)	2.92 (74.2)	3.69 (93.7)
L	.34 (8.6)	.34 (8.6)	.41 (10.4)	.41 (10.4)
M	1.12 (28.4)	1.12 (28.4)	1.25 (31.8)	1.56 (39.6)
N	.25 (6.4)	.25 (6.4)	.31 (7.9)	.31 (7.9)
P	2.12 (53.8)	2.18 (55.4)	2.63 (66.8)	3.06 (77.7)

Inches (mm)



For inventory, lead times, and kit lookup, visit www.pdnplu.com

Knob Operated, Manual Return, Stem Stop

M085 Stem Stop, Small Bracket

3-Way

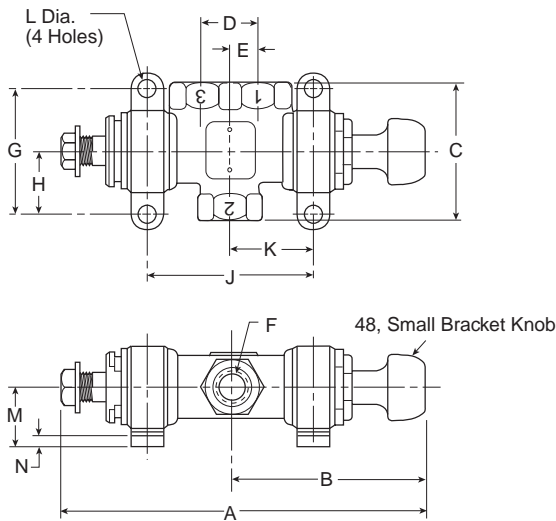

	1/4	3/8	1/2	3/4
A	5.99 (152.2)	6.69 (169.9)	7.90 (200.7)	9.60 (243.8)
B	3.32 (84.3)	3.64 (92.5)	4.17 (105.9)	4.99 (126.8)
C	2.38 (60.4)	2.62 (66.6)	3.00 (76.2)	3.62 (92.0)
D	0.94 (23.9)	1.06 (26.9)	1.25 (31.8)	1.62 (41.2)
E	0.47 (11.9)	0.53 (13.5)	0.62 (15.8)	0.81 (20.6)
F	1/4" Pipe	3/8" Pipe	1/2" Pipe	3/4" Pipe
G	2.25 (57.2)	2.38 (60.4)	2.62 (66.6)	3.25 (82.6)
H	1.12 (28.4)	1.19 (30.2)	1.31 (33.3)	1.62 (41.2)
J	2.64 (67.1)	3.14 (79.8)	3.73 (94.7)	4.67 (118.6)
K	1.32 (33.5)	1.57 (39.9)	1.87 (47.5)	2.33 (59.2)
L	0.34 (8.6)	0.34 (8.6)	0.41 (10.4)	0.41 (10.4)
M	1.12 (28.4)	1.12 (28.4)	1.25 (31.8)	1.56 (39.6)
N	0.25 (6.4)	0.25 (6.4)	0.31 (7.9)	0.31 (7.9)
Travel	0.62 (15.7)	0.69 (17.5)	0.88 (22.4)	1.12 (28.4)

Inches (mm)

M085 Stem Stop, Small Bracket

4-Way

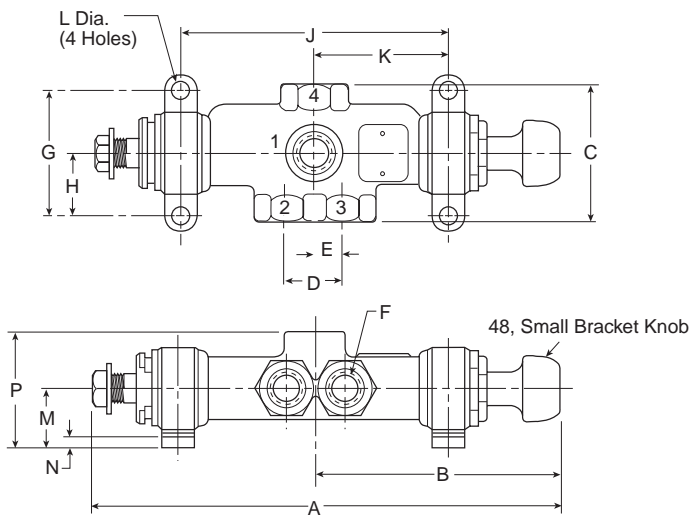

	1/4	3/8	1/2	3/4
A	7.49 (190.2)	8.53 (216.7)	10.01 (254.2)	12.31 (312.7)
B	4.02 (102.1)	4.56 (115.8)	5.73 (145.5)	6.34 (161.0)
C	2.38 (60.4)	2.62 (66.6)	3.12 (79.2)	3.62 (92.0)
D	0.94 (23.9)	1.06 (26.9)	1.25 (31.8)	1.62 (41.2)
E	0.47 (11.9)	0.53 (13.5)	0.62 (15.8)	0.81 (20.6)
F	1/4" Pipe	3/8" Pipe	1/2" Pipe	3/4" Pipe
G	2.25 (57.2)	2.38 (60.4)	2.62 (66.6)	3.25 (82.6)
H	1.12 (28.4)	1.19 (30.2)	1.31 (33.3)	1.62 (41.2)
J	4.14 (105.2)	4.98 (126.5)	5.85 (148.6)	7.39 (187.7)
K	2.07 (52.6)	2.49 (63.2)	2.93 (74.4)	3.69 (93.7)
L	0.34 (8.6)	0.34 (8.6)	0.41 (10.4)	0.41 (10.4)
M	1.12 (28.4)	1.12 (28.4)	1.25 (31.8)	1.56 (39.6)
N	0.25 (6.4)	0.25 (6.4)	0.31 (7.9)	0.31 (7.9)
P	2.12 (53.8)	2.18 (55.4)	2.63 (66.8)	3.06 (77.7)
Travel	0.62 (15.7)	0.69 (17.5)	0.88 (22.4)	1.12 (28.4)

Inches (mm)



For inventory, lead time, and kit lookup, visit www.pdnplu.com

Directair 2
& 4 Series

Viking Xtreme
Lever Series

42 Lever/
Pedal Series

MO Series

Safety



Manual / Mechanical
Valves

Brass Poppet /
Sliding Seal

Control Panel
Products

Sensing

Dimensional Data

MO Series

Knob & Palm Button Operated, Light Spring Return

M097 Light Spring Return Direct Acting, Small Bracket (Pull Knob)

3-Way

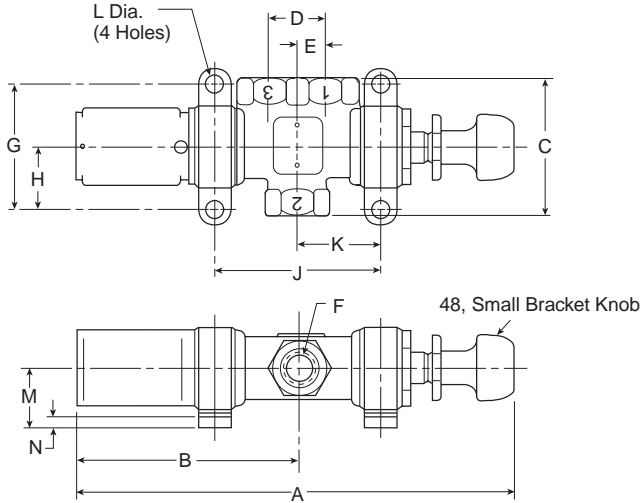

	1/4	3/8	1/2	3/4
A	7.86 (199.8)	8.55 (217.2)	10.36 (263.1)	13.01 (330.4)
B	3.92 (99.6)	4.24 (107.7)	5.32 (135.2)	6.92 (175.8)
C	2.38 (60.4)	2.62 (66.6)	3.00 (76.2)	3.62 (92.0)
D	0.94 (23.9)	1.06 (26.9)	1.25 (31.8)	1.62 (41.2)
E	0.47 (11.9)	0.53 (13.5)	0.62 (15.8)	0.81 (20.6)
F	1/4" Pipe	3/8" Pipe	1/2" Pipe	3/4" Pipe
G	2.25 (57.2)	2.38 (60.4)	2.62 (66.6)	3.25 (82.6)
H	1.12 (28.4)	1.19 (30.2)	1.31 (33.3)	1.62 (41.2)
J	2.64 (67.1)	3.14 (79.8)	3.73 (94.7)	4.67 (118.6)
K	1.32 (33.5)	1.57 (39.9)	1.87 (47.5)	2.33 (59.2)
L	0.34 (8.6)	0.34 (8.6)	0.41 (10.4)	0.41 (10.4)
M	1.12 (28.4)	1.12 (28.4)	1.25 (31.8)	1.56 (39.6)
N	0.25 (6.4)	0.25 (6.4)	0.31 (7.9)	0.31 (7.9)
Travel	0.62 (15.7)	0.69 (17.5)	0.88 (22.4)	1.12 (28.4)

Inches (mm)

M097 Light Spring Return Direct Acting, Small Bracket (Pull Knob)

4-Way

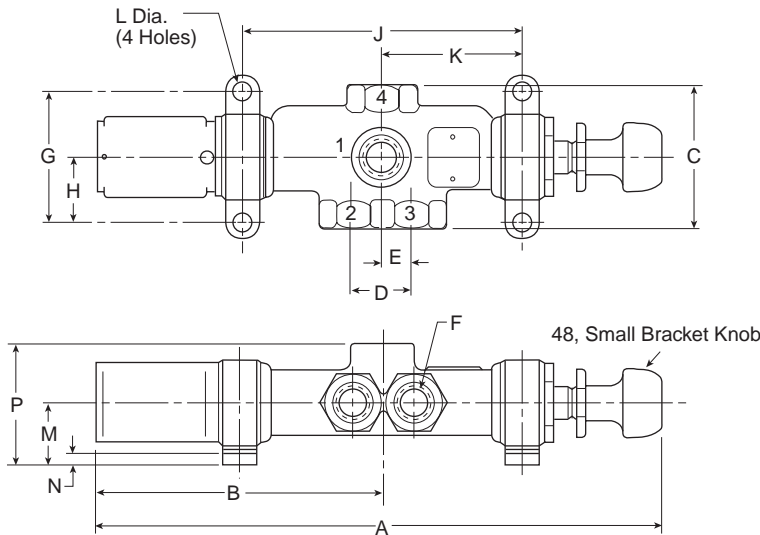

	1/4	3/8	1/2	3/4
A	9.36 (237.9)	10.39 (263.9)	12.48 (317.0)	15.73 (399.5)
B	4.67 (118.5)	5.15 (130.8)	6.37 (161.8)	8.27 (210.1)
C	2.38 (60.4)	2.62 (66.6)	3.12 (79.2)	3.62 (92.0)
D	0.94 (23.9)	1.06 (26.9)	1.25 (31.8)	1.62 (41.2)
E	0.47 (11.9)	0.53 (13.5)	0.62 (15.8)	0.81 (20.6)
F	1/4" Pipe	3/8" Pipe	1/2" Pipe	3/4" Pipe
G	2.25 (57.2)	2.38 (60.4)	2.62 (66.6)	3.25 (82.6)
H	1.12 (28.4)	1.19 (30.2)	1.31 (33.3)	1.62 (41.2)
J	4.14 (105.2)	4.98 (126.5)	5.85 (148.6)	7.39 (187.7)
K	2.07 (52.6)	2.49 (63.2)	2.93 (74.4)	3.69 (93.7)
L	0.34 (8.6)	0.34 (8.6)	0.41 (10.4)	0.41 (10.4)
M	1.12 (28.4)	1.12 (28.4)	1.25 (31.8)	1.56 (39.6)
N	0.25 (6.4)	0.25 (6.4)	0.31 (7.9)	0.31 (7.9)
P	2.12 (53.8)	2.18 (55.4)	2.63 (66.8)	3.06 (77.7)
Travel	0.62 (15.7)	0.69 (17.5)	0.88 (22.4)	1.12 (28.4)

Inches (mm)



For inventory, lead times, and kit lookup, visit www.pdnplu.com

**Panel Mounted, Knob & Button Operated,
 Light Spring Return**

**M064 Direct Acting, Less Bracket (Pull Knob) &
 M065 Reverse Acting, Less Bracket (Push Knob)**

3-Way

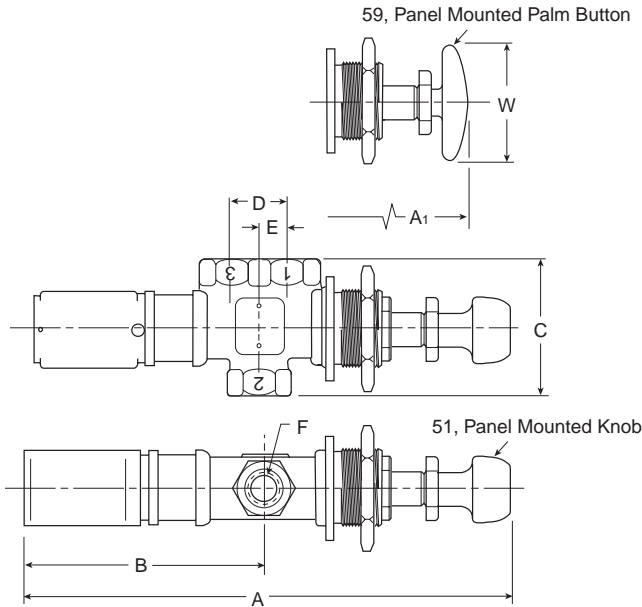

	1/4	3/8	1/2	3/4
A	7.86 (199.6)	8.55 (217.1)	10.36 (263.1)	13.01 (330.4)
A1	7.55 (191.8)	8.24 (209.3)	10.05 (255.3)	12.70 (322.6)
B	3.96 (99.5)	4.23 (107.4)	5.31 (134.9)	6.91 (175.5)
C	2.38 (60.4)	2.62 (66.6)	3.00 (76.2)	3.62 (92.0)
D	0.94 (23.9)	1.06 (26.9)	1.25 (31.8)	1.62 (41.2)
E	0.47 (11.9)	0.53 (13.5)	0.62 (15.8)	0.81 (20.6)
F	1/4" Pipe	3/8" Pipe	1/2" Pipe	3/4" Pipe
W	2.25 (57.2)	2.25 (57.2)	2.25 (57.2)	2.25 (57.2)
Travel	0.62 (15.7)	0.69 (17.5)	0.88 (22.4)	1.12 (28.4)

Inches (mm)

**M064 Direct Acting, Less Bracket (Pull Knob) &
 M065 Reverse Acting, Less Bracket (Push Knob)**

4-Way

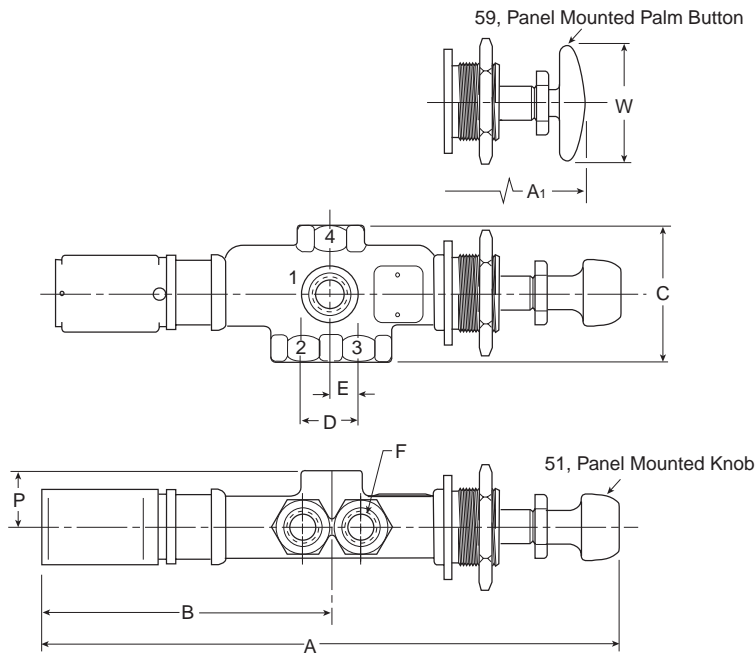

	1/4	3/8	1/2	3/4
A	9.36 (237.7)	10.39 (263.9)	12.48 (317.0)	15.73 (399.5)
A1	9.05 (229.9)	10.08 (256.0)	12.17 (309.1)	15.42 (391.7)
B	4.67 (118.5)	5.15 (130.8)	6.37 (161.8)	8.27 (210.1)
C	2.38 (60.4)	2.62 (66.6)	3.12 (79.2)	3.62 (92.0)
D	0.94 (23.9)	1.06 (26.9)	1.25 (31.8)	1.62 (41.2)
E	0.47 (11.9)	0.53 (13.5)	0.62 (15.8)	0.81 (20.6)
F	1/4" Pipe	3/8" Pipe	1/2" Pipe	3/4" Pipe
P	2.12 (53.8)	2.18 (55.4)	2.63 (66.8)	3.06 (77.7)
W	2.25 (57.2)	2.25 (57.2)	2.25 (57.2)	2.25 (57.2)
Travel	0.62 (15.7)	0.69 (17.5)	0.88 (22.4)	1.12 (28.4)

Inches (mm)



For inventory, lead time, and kit lookup, visit www.pdnplu.com

Directair 2
& 4 Series

Viking Xtreme
Lever Series

42 Lever/
Pedal Series

MO Series

Safety



Manual / Mechanical
Valves

Brass Poppet /
Sliding Seal

Control Panel
Products

Sensing

Dimensional Data

MO Series

Lever Operated, Manual Return, Stem Stop

M085 Stem Stop, Small Bracket

3-Way

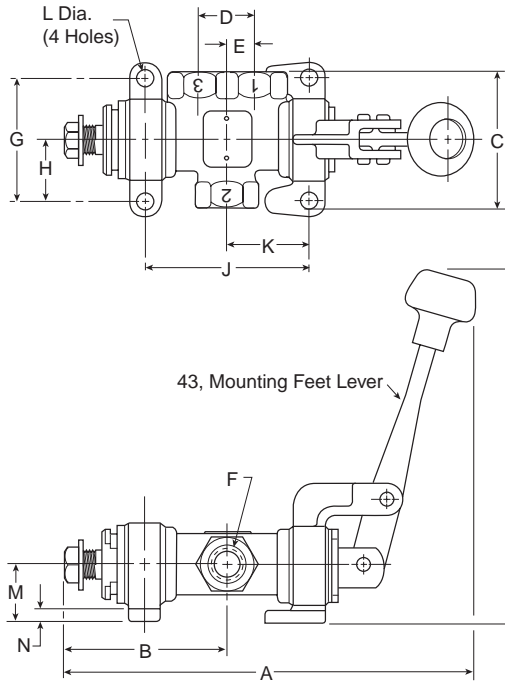

	1/4	3/8	1/2	3/4
A	6.77 (172.0)	7.76 (197.1)	9.29 (236.0)	11.46 (291.1)
B	2.67 (67.8)	3.05 (77.5)	3.72 (94.5)	4.61 (117.1)
C	2.38 (60.4)	2.62 (66.6)	3.00 (76.2)	3.62 (92.0)
D	0.94 (23.9)	1.06 (26.9)	1.25 (31.8)	1.62 (41.2)
E	0.47 (11.9)	0.53 (13.5)	0.62 (15.8)	0.81 (20.6)
F	1/4" Pipe	3/8" Pipe	1/2" Pipe	3/4" Pipe
G	2.25 (57.2)	2.38 (60.4)	2.62 (66.6)	3.25 (82.6)
H	1.12 (28.4)	1.19 (30.2)	1.31 (33.3)	1.62 (41.2)
J	2.63 (66.8)	3.13 (79.5)	3.72 (94.5)	4.56 (115.8)
K	1.31 (33.3)	1.56 (39.6)	1.86 (47.2)	2.28 (57.9)
L	0.34 (8.6)	0.34 (8.6)	0.41 (10.4)	0.41 (10.4)
M	1.12 (28.4)	1.12 (28.4)	1.25 (31.8)	1.56 (39.6)
N	0.25 (6.4)	0.25 (6.4)	0.31 (7.9)	0.31 (7.9)
R	6.78 (172.2)	6.78 (172.2)	8.10 (205.7)	10.73 (272.5)
Travel	0.62 (15.7)	0.69 (17.5)	0.88 (22.4)	1.12 (28.4)

Inches (mm)

M085 Stem Stop, Small Bracket

4-Way

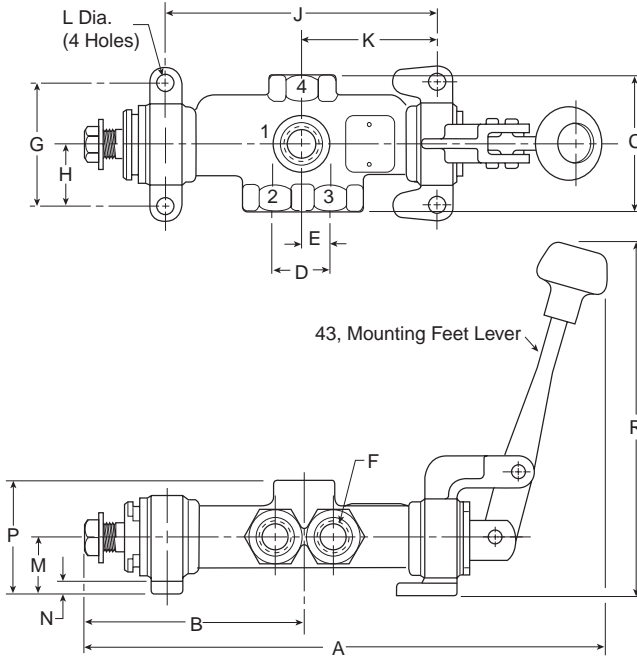

	1/4	3/8	1/2	3/4
A	8.28 (210.3)	9.60 (243.8)	11.08 (281.4)	14.17 (359.9)
B	3.42 (86.9)	3.97 (100.8)	4.78 (121.4)	5.97 (151.6)
C	2.38 (60.4)	2.62 (66.6)	3.12 (79.2)	3.62 (92.0)
D	0.94 (23.9)	1.06 (26.9)	1.25 (31.8)	1.62 (41.2)
E	0.47 (11.9)	0.53 (13.5)	0.62 (15.8)	0.81 (20.6)
F	1/4" Pipe	3/8" Pipe	1/2" Pipe	3/4" Pipe
G	2.25 (57.2)	2.38 (60.4)	2.62 (66.6)	3.25 (82.6)
H	1.12 (28.4)	1.19 (30.2)	1.31 (33.3)	1.62 (41.2)
J	4.14 (105.2)	4.98 (126.5)	5.85 (148.6)	7.39 (187.7)
K	2.07 (52.6)	2.49 (63.2)	2.92 (74.2)	3.69 (93.7)
L	0.34 (8.6)	0.34 (8.6)	0.41 (10.4)	0.41 (10.4)
M	1.12 (28.4)	1.12 (28.4)	1.25 (31.8)	1.56 (39.6)
N	0.25 (6.4)	0.25 (6.4)	0.31 (7.9)	0.31 (7.9)
P	2.12 (53.8)	2.18 (55.4)	2.63 (66.8)	3.06 (77.7)
R	6.78 (172.2)	6.78 (172.2)	8.10 (205.7)	10.73 (272.5)
Travel	0.62 (15.7)	0.69 (17.5)	0.88 (22.4)	1.12 (28.4)

Inches (mm)



For inventory, lead times, and kit lookup, visit www.pdnplu.com

Directair 2 & 4 Series
Viking Xtreme Lever Series
42 Lever / Pedal Series
MO Series
Safety
Manual / Mechanical Valves
Brass Poppet / Sliding Seal
Control Panel Products
Sensing

Lever Operated, Spring Return

M095 Direct Acting, Small Bracket (Push Lever) & M096 Reverse Acting, Small Bracket (Pull Lever)

3-Way

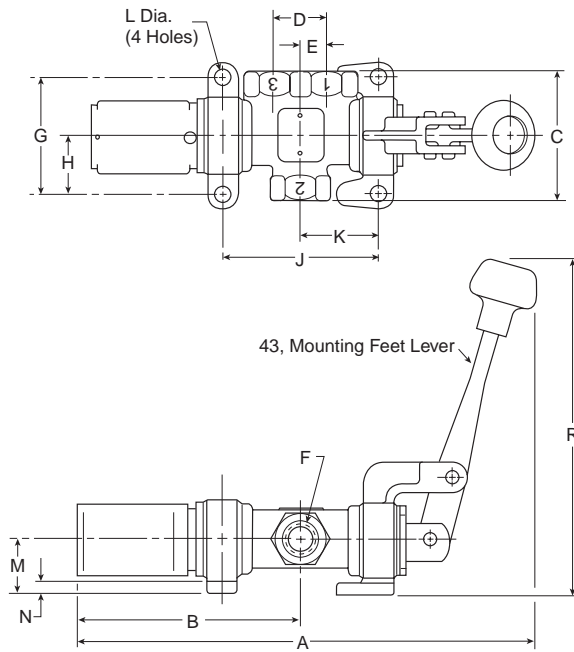

	1/4	3/8	1/2	3/4
A	7.99 (202.8)	8.94 (227.0)	10.88 (276.4)	13.76 (349.5)
B	3.92 (99.5)	4.24 (107.6)	5.31 (134.9)	6.92 (175.8)
C	2.38 (60.4)	2.62 (66.6)	3.00 (76.2)	3.62 (92.0)
D	0.94 (23.9)	1.06 (26.9)	1.25 (31.8)	1.62 (41.2)
E	0.47 (11.9)	0.53 (13.5)	0.62 (15.8)	0.81 (20.6)
F	1/4" Pipe	3/8" Pipe	1/2" Pipe	3/4" Pipe
G	2.25 (57.2)	2.38 (60.4)	2.62 (66.6)	3.25 (82.6)
H	1.12 (28.4)	1.19 (30.2)	1.31 (33.3)	1.62 (41.2)
J	2.63 (66.8)	3.13 (79.5)	3.72 (94.5)	4.56 (115.8)
K	1.31 (33.3)	1.56 (39.6)	1.86 (47.2)	2.28 (57.9)
L	0.34 (8.6)	0.34 (8.6)	0.41 (10.4)	0.41 (10.4)
M	1.12 (28.4)	1.12 (28.4)	1.25 (31.8)	1.56 (39.6)
N	0.25 (6.4)	0.25 (6.4)	0.31 (7.9)	0.31 (7.9)
R	6.78 (172.2)	6.78 (172.2)	8.10 (205.7)	10.73 (272.5)
Travel	0.62 (15.7)	0.69 (17.5)	0.88 (22.4)	1.12 (28.4)

Inches (mm)

M095 Direct Acting, Small Bracket (Push Lever) & M096 Reverse Acting, Small Bracket (Pull Lever)

3-Way

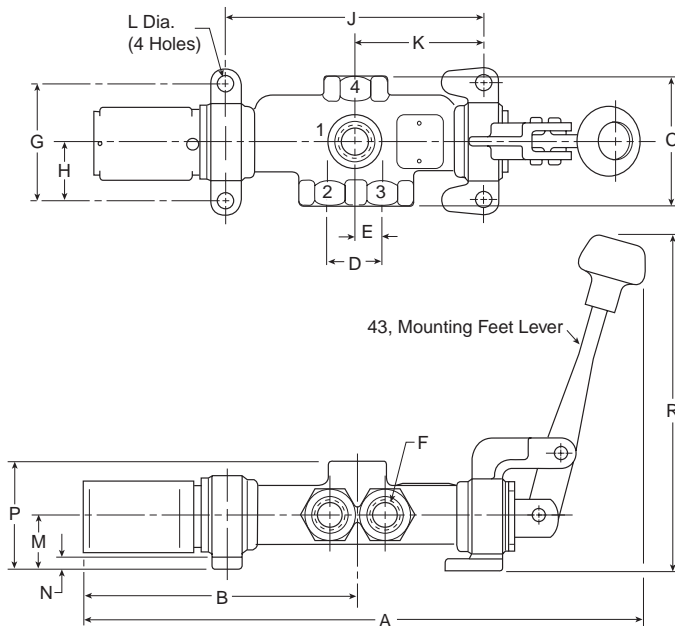

	1/4	3/8	1/2	3/4
A	9.53 (242.1)	10.78 (273.8)	12.67 (321.8)	16.47 (418.3)
B	4.67 (118.6)	5.15 (130.8)	5.68 (144.3)	8.27 (210.1)
C	2.38 (60.4)	2.62 (66.6)	3.12 (79.2)	3.62 (92.0)
D	0.94 (23.9)	1.06 (26.9)	1.25 (31.8)	1.62 (41.2)
E	0.47 (11.9)	0.53 (13.5)	0.62 (15.8)	0.81 (20.6)
F	1/4" Pipe	3/8" Pipe	1/2" Pipe	3/4" Pipe
G	2.25 (57.2)	2.38 (60.4)	2.62 (66.6)	3.25 (82.6)
H	1.12 (28.4)	1.19 (30.2)	1.31 (33.3)	1.62 (41.2)
J	4.14 (105.2)	4.98 (126.5)	5.85 (148.6)	7.39 (187.7)
K	2.07 (52.6)	2.49 (63.2)	2.92 (74.2)	3.69 (93.7)
L	0.34 (8.6)	0.34 (8.6)	0.41 (10.4)	0.41 (10.4)
M	1.12 (28.4)	1.12 (28.4)	1.25 (31.8)	1.56 (39.6)
N	0.25 (6.4)	0.25 (6.4)	0.31 (7.9)	0.31 (7.9)
P	2.12 (53.8)	2.18 (55.4)	2.63 (66.8)	3.06 (77.7)
R	6.78 (172.2)	6.78 (172.2)	8.10 (205.7)	10.73 (272.5)
Travel	0.62 (15.7)	0.69 (17.5)	0.88 (22.4)	1.12 (28.4)

Inches (mm)



For inventory, lead time, and kit lookup, visit www.pdnplu.com

Directair 2
& 4 Series

Viking Xtreme
Lever Series

42 Lever/
Pedal Series

MO Series

Safety



Manual / Mechanical
Valves

Brass Poppet /
Sliding Seal

Control Panel
Products

Sensing

Dimensional Data

MO Series

Treadle Operated, Manual Return, Stem Stop

M085 Stem Stop, Small Bracket

3-Way

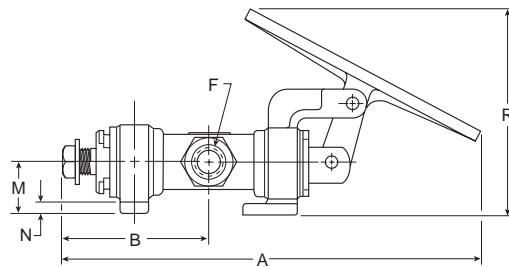
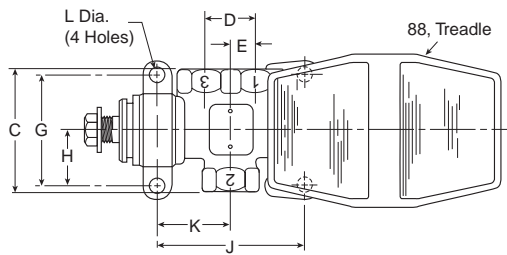

	1/4	3/8	1/2
A	8.01 (203.4)	8.73 (221.7)	10.32 (262.1)
B	2.67 (68.8)	3.06 (77.7)	4.06 (103.1)
C	2.38 (60.4)	2.62 (66.6)	3.00 (76.2)
D	0.94 (23.9)	1.06 (26.9)	1.25 (31.8)
E	0.47 (11.9)	0.53 (13.5)	0.62 (15.8)
F	1/4" Pipe	3/8" Pipe	1/2" Pipe
G	2.25 (57.2)	2.38 (60.4)	2.62 (66.6)
H	1.12 (28.4)	1.19 (30.2)	1.31 (33.3)
J	2.63 (66.8)	3.13 (79.5)	3.72 (94.5)
K	1.31 (33.3)	1.56 (39.6)	1.86 (47.2)
L	0.34 (8.6)	0.34 (8.6)	0.41 (10.4)
M	1.12 (28.4)	1.12 (28.4)	1.25 (31.8)
N	0.25 (6.4)	0.25 (6.4)	0.31 (7.9)
R	4.51 (114.6)	4.65 (118.1)	4.85 (123.2)
Travel	0.62 (15.8)	0.69 (17.5)	0.88 (22.4)

Inches (mm)

M085 Stem Stop, Small Bracket

4-Way

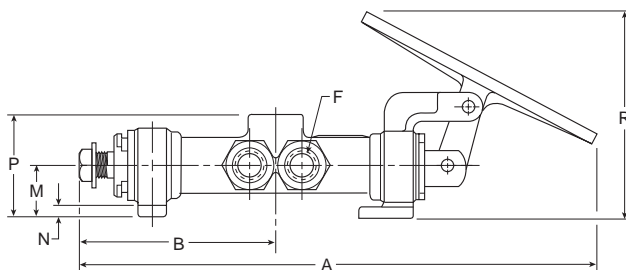
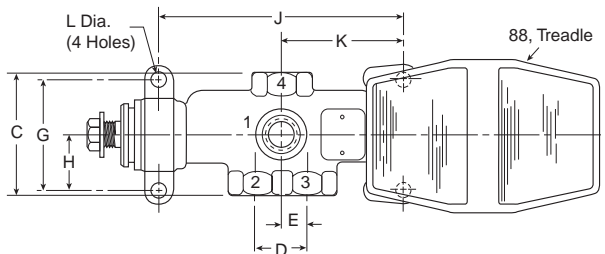

	1/4	3/8	1/2
A	9.52 (241.8)	10.57 (268.5)	12.11 (307.6)
B	3.42 (86.9)	3.97 (100.8)	4.78 (121.4)
C	2.38 (60.4)	2.62 (66.6)	3.12 (79.2)
D	0.94 (23.9)	1.06 (26.9)	1.25 (31.8)
E	0.47 (11.9)	0.53 (13.5)	0.62 (15.8)
F	1/4" Pipe	3/8" Pipe	1/2" Pipe
G	2.25 (57.2)	2.38 (60.4)	2.62 (66.6)
H	1.12 (28.4)	1.19 (30.2)	1.31 (33.3)
J	4.14 (105.2)	4.98 (126.5)	5.85 (148.6)
K	2.07 (52.6)	2.49 (63.2)	2.92 (74.2)
L	0.34 (8.6)	0.34 (8.6)	0.41 (10.4)
M	1.12 (28.4)	1.12 (28.4)	1.25 (31.8)
N	0.25 (6.4)	0.25 (6.4)	0.31 (7.9)
P	2.12 (53.8)	2.18 (55.4)	2.63 (66.8)
R	4.51 (114.6)	4.65 (118.1)	4.85 (123.2)
Travel	0.62 (15.8)	0.69 (17.5)	0.88 (22.4)

Inches (mm)



For inventory, lead times, and kit lookup, visit www.pdnplu.com

Directair 2 & 4 Series
Viking Xtreme Lever Series
42 Lever / Pedal Series
MO Series
Safety
Manual / Mechanical Valves
Brass Poppet / Sliding Seal
Control Panel Products
Sensing

Pedal Operated, Spring Return

M062 Direct Acting Spring Return, Less Bracket (Push Lever)
3-Way

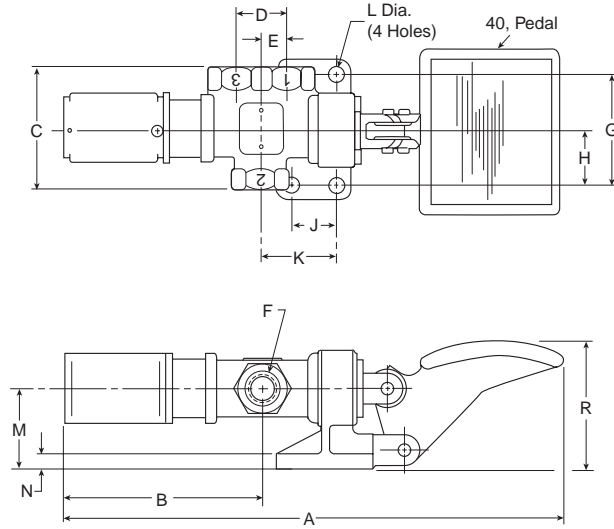

	1/4	3/8	1/2
A	9.99 (253.8)	10.50 (269.2)	12.66 (321.6)
B	3.92 (99.5)	4.23 (107.4)	5.31 (134.9)
C	2.38 (60.4)	2.62 (66.6)	3.00 (76.2)
D	0.94 (23.9)	1.06 (26.9)	1.25 (31.8)
E	0.47 (11.9)	0.53 (13.5)	0.62 (15.8)
F	1/4" Pipe	3/8" Pipe	1/2" Pipe
G	2.25 (57.2)	2.38 (60.4)	2.62 (66.6)
H	1.12 (28.4)	1.19 (30.2)	1.31 (33.3)
J	0.97 (24.6)	0.97 (24.6)	1.12 (28.4)
K	1.44 (36.6)	1.56 (39.6)	1.83 (46.5)
L	0.34 (8.6)	0.34 (8.6)	0.41 (10.4)
M	1.72 (43.7)	1.72 (43.7)	2.00 (50.8)
N	0.31 (7.9)	0.31 (7.9)	0.38 (9.6)
R	2.66 (67.6)	2.71 (68.8)	2.74 (69.6)
Travel	0.62 (15.8)	0.69 (17.5)	0.88 (22.4)

Inches (mm)

M062 Direct Acting Spring Return, Less Bracket (Push Lever)
4-Way

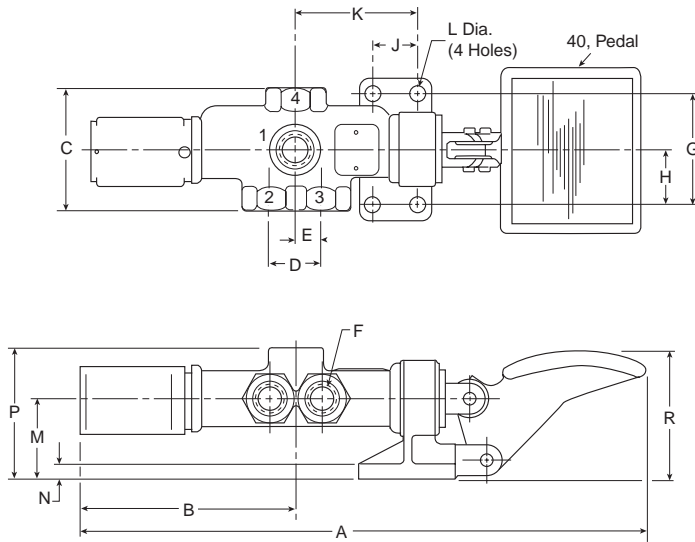

	1/4	3/8	1/2
A	11.50 (292.1)	12.44 (315.9)	14.45 (367.0)
B	4.67 (118.5)	5.15 (130.8)	5.68 (144.3)
C	2.38 (60.4)	2.62 (66.6)	3.00 (76.2)
D	0.94 (23.9)	1.06 (26.9)	1.25 (31.8)
E	0.47 (11.9)	0.53 (13.5)	0.62 (15.8)
F	1/4" Pipe	3/8" Pipe	1/2" Pipe
G	2.25 (57.2)	2.38 (60.4)	2.62 (66.6)
H	1.12 (28.4)	1.19 (30.2)	1.31 (33.3)
J	0.97 (24.6)	0.97 (24.6)	1.12 (28.4)
K	2.19 (55.6)	2.48 (63.0)	2.89 (73.4)
L	0.34 (8.6)	0.34 (8.6)	0.41 (10.4)
M	1.72 (43.7)	1.72 (43.7)	2.00 (50.8)
N	0.31 (7.9)	0.31 (7.9)	0.38 (9.6)
P	2.72 (69.1)	2.78 (70.6)	3.38 (85.8)
R	2.66 (67.6)	2.71 (68.8)	2.74 (69.6)
Travel	0.62 (15.8)	0.69 (17.5)	0.88 (22.4)

Inches (mm)



For inventory, lead time, and kit lookup, visit www.pdnplu.com



Dimensional Data

MO Series

Clevis Operated, Mechanical Return, Stem Stop

M085 Stem Stop, Small Bracket

3-Way

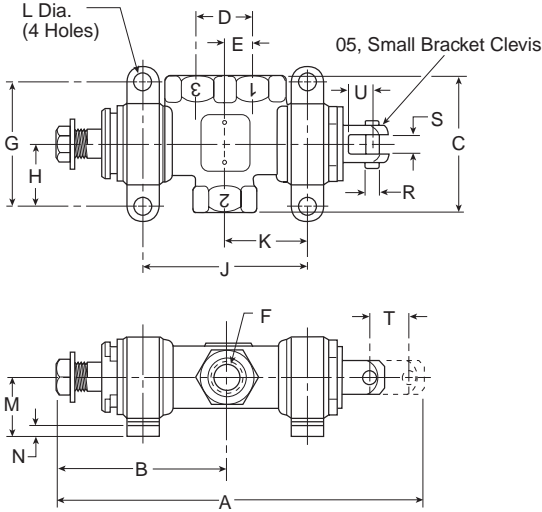

Inches (mm)

	1/4	3/8	1/2	3/4
A	5.31 (134.9)	6.01 (152.6)	7.36 (186.9)	8.92 (226.6)
B	2.68 (68.1)	3.06 (77.7)	4.85 (123.2)	4.62 (117.3)
C	2.38 (60.4)	2.62 (66.6)	3.00 (76.2)	3.62 (92.0)
D	0.94 (23.9)	1.06 (26.9)	1.25 (31.8)	1.62 (41.2)
E	0.47 (11.9)	0.53 (13.5)	0.62 (15.8)	0.81 (20.6)
F	1/4" Pipe	3/8" Pipe	1/2" Pipe	3/4" Pipe
G	2.25 (57.2)	2.38 (60.4)	2.62 (66.6)	3.25 (82.6)
H	1.12 (28.4)	1.19 (30.2)	1.31 (33.3)	1.62 (41.2)
J	2.64 (67.1)	3.14 (79.8)	3.73 (94.7)	4.67 (118.6)
K	1.32 (33.5)	1.57 (39.9)	1.87 (47.5)	2.33 (59.2)
L	0.34 (8.6)	0.34 (8.6)	0.41 (10.4)	0.41 (10.4)
M	1.12 (28.4)	1.12 (28.4)	1.25 (31.8)	1.56 (39.6)
N	0.25 (6.4)	0.25 (6.4)	0.31 (7.9)	0.31 (7.9)
R	0.25 (6.4)	0.25 (6.4)	0.31 (7.9)	0.31 (7.9)
S	0.38 (9.6)	0.38 (9.6)	0.44 (11.2)	0.44 (11.2)
U	0.47 (11.9)	0.47 (11.9)	0.56 (14.2)	0.62 (15.8)
Travel	0.62 (15.8)	0.69 (17.5)	0.88 (22.4)	1.12 (28.4)

M085 Stem Stop, Small Bracket

4-Way

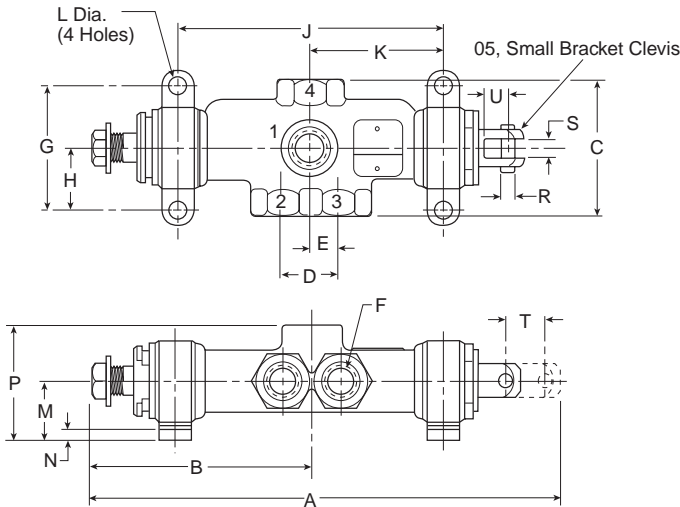

Inches (mm)

	1/4	3/8	1/2	3/4
A	6.81 (173.0)	7.85 (199.4)	9.48 (240.8)	11.64 (295.7)
B	3.42 (86.9)	3.97 (100.8)	5.91 (150.1)	5.97 (151.6)
C	2.38 (60.4)	2.62 (66.6)	3.12 (79.2)	3.62 (92.0)
D	0.94 (23.9)	1.06 (26.9)	1.25 (31.8)	1.62 (41.2)
E	0.47 (11.9)	0.53 (13.5)	0.62 (15.8)	0.81 (20.6)
F	1/4" Pipe	3/8" Pipe	1/2" Pipe	3/4" Pipe
G	2.25 (57.2)	2.38 (60.4)	2.62 (66.6)	3.25 (82.6)
H	1.12 (28.4)	1.19 (30.2)	1.31 (33.3)	1.62 (41.2)
J	4.14 (105.2)	4.98 (126.5)	5.85 (148.6)	7.39 (187.7)
K	2.07 (52.6)	2.49 (63.2)	2.92 (74.2)	3.69 (93.7)
L	0.34 (8.6)	0.34 (8.6)	0.41 (10.4)	0.41 (10.4)
M	1.12 (28.4)	1.12 (28.4)	1.25 (31.8)	1.56 (39.6)
N	0.25 (6.4)	0.25 (6.4)	0.31 (7.9)	0.31 (7.9)
P	2.12 (53.8)	2.18 (55.4)	2.63 (66.8)	3.06 (77.7)
R	0.25 (6.4)	0.25 (6.4)	0.31 (7.9)	0.31 (7.9)
S	0.38 (9.6)	0.38 (9.6)	0.44 (11.2)	0.44 (11.2)
U	0.47 (11.9)	0.47 (11.9)	0.56 (14.2)	0.62 (15.8)
Travel	0.62 (15.8)	0.69 (17.5)	0.88 (22.4)	1.12 (28.4)



For inventory, lead times, and kit lookup, visit www.pdnplu.com

Clevis Operated, Spring Return, Small Bracket

M095 Direct Acting (Push Lever) & M096 Reverse Acting (Pull Lever)

3-Way

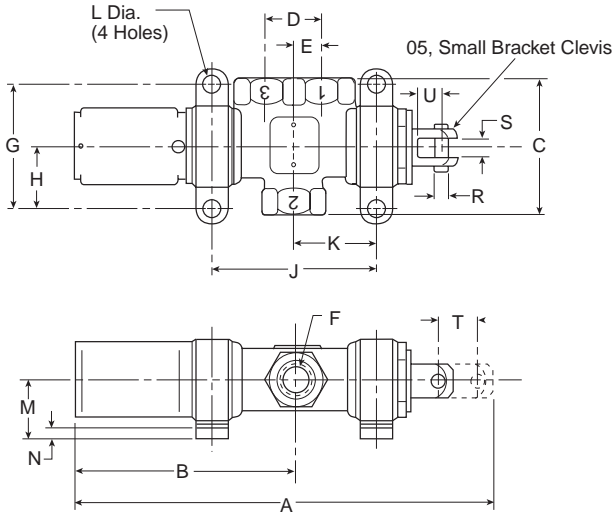

Inches (mm)

	1/4	3/8	1/2	3/4
A	6.56 (166.5)	7.19 (182.6)	8.95 (227.3)	11.22 (285.0)
B	3.92 (99.5)	4.24 (107.6)	5.31 (134.9)	6.92 (175.8)
C	2.38 (60.4)	2.62 (66.6)	3.00 (76.2)	3.62 (92.0)
D	0.94 (23.9)	1.06 (26.9)	1.25 (31.8)	1.62 (41.2)
E	0.47 (11.9)	0.53 (13.5)	0.62 (15.8)	0.81 (20.6)
F	1/4" Pipe	3/8" Pipe	1/2" Pipe	3/4" Pipe
G	2.25 (57.2)	2.38 (60.4)	2.62 (66.6)	3.25 (82.6)
H	1.12 (28.4)	1.19 (30.2)	1.31 (33.3)	1.62 (41.2)
J	2.63 (66.8)	3.13 (79.5)	3.72 (94.5)	4.56 (115.8)
K	1.31 (33.3)	1.56 (39.6)	1.86 (47.2)	2.28 (57.9)
L	0.34 (8.6)	0.34 (8.6)	0.41 (10.4)	0.41 (10.4)
M	1.12 (28.4)	1.12 (28.4)	1.25 (31.8)	1.56 (39.6)
N	0.25 (6.4)	0.25 (6.4)	0.31 (7.9)	0.31 (7.9)
R	0.25 (6.4)	0.25 (6.4)	0.31 (7.9)	0.31 (7.9)
S	0.38 (9.6)	0.38 (9.6)	0.44 (11.2)	0.44 (11.2)
U	0.47 (11.9)	0.47 (11.9)	0.56 (14.2)	0.62 (15.8)
Travel	0.62 (15.8)	0.69 (17.5)	0.88 (22.4)	1.12 (28.4)

M095 Direct Acting (Push Lever) & M096 Reverse Acting (Pull Lever)

4-Way

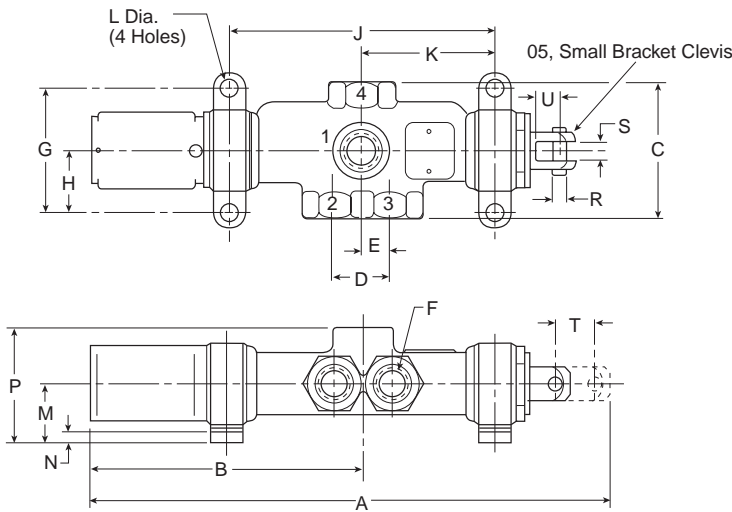

Inches (mm)

	1/4	3/8	1/2	3/4
A	8.06 (204.6)	9.03 (229.3)	11.07 (281.2)	13.94 (354.1)
B	4.67 (118.6)	5.15 (130.8)	5.68 (144.3)	8.27 (210.1)
C	2.38 (60.4)	2.62 (66.6)	3.00 (76.2)	3.62 (92.0)
D	0.94 (23.9)	1.06 (26.9)	1.25 (31.8)	1.62 (41.2)
E	0.47 (11.9)	0.53 (13.5)	0.62 (15.8)	0.81 (20.6)
F	1/4" Pipe	3/8" Pipe	1/2" Pipe	3/4" Pipe
G	2.25 (57.2)	2.38 (60.4)	2.62 (66.6)	3.25 (82.6)
H	1.12 (28.4)	1.19 (30.2)	1.31 (33.3)	1.62 (41.2)
J	4.14 (105.2)	4.98 (126.5)	5.85 (148.6)	7.39 (187.7)
K	2.07 (52.6)	2.49 (63.2)	2.9 (74.2)	3.69 (93.7)
L	0.34 (8.6)	0.34 (8.6)	0.41 (10.4)	0.41 (10.4)
M	1.12 (28.4)	1.12 (28.4)	1.25 (31.8)	1.56 (39.6)
N	0.25 (6.4)	0.25 (6.4)	0.31 (7.9)	0.31 (7.9)
P	2.12 (53.8)	2.18 (55.4)	2.63 (66.8)	3.06 (77.7)
R	0.25 (6.4)	0.25 (6.4)	0.31 (7.9)	0.31 (7.9)
S	0.38 (9.6)	0.38 (9.6)	0.44 (11.2)	0.44 (11.2)
U	0.47 (11.9)	0.47 (11.9)	0.56 (14.2)	0.62 (15.8)
Travel	0.62 (15.8)	0.69 (17.5)	0.88 (22.4)	1.12 (28.4)



For inventory, lead time, and kit lookup, visit www.pdnplu.com



Dimensional Data

MO Series

Single Diaphragm Operated, Spring Return Stem Stop

M084 Stem Stop, Large Bracket

3-Way

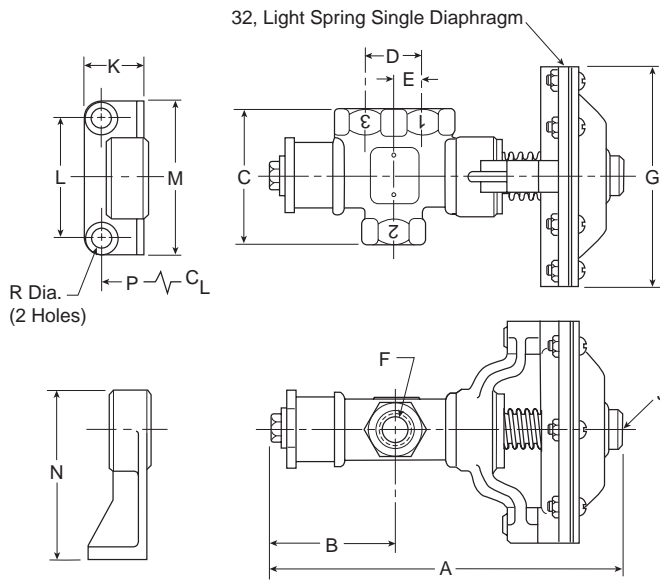

	1/4	3/8	1/2	3/4
A	6.14 (156.0)	6.85 (174.0)	8.03 (204.0)	9.89 (251.2)
B	2.03 (51.6)	2.36 (59.9)	2.83 (71.9)	3.48 (88.4)
C	2.38 (60.4)	2.62 (66.6)	3.00 (76.2)	3.62 (92.0)
D	0.94 (23.9)	1.06 (26.9)	1.25 (31.8)	1.62 (41.2)
E	0.47 (11.9)	0.53 (13.5)	0.62 (15.8)	0.81 (20.6)
F	1/4" Pipe	3/8" Pipe	1/2" Pipe	3/4" Pipe
G	4.34 (110.2)	4.34 (110.2)	4.34 (110.2)	5.27 (133.9)
J	1/8" Pipe	1/8" Pipe	1/8" Pipe	1/8" Pipe
K	1.12 (28.4)	1.12 (28.4)	1.75 (44.4)	2.00 (50.8)
L	2.00 (50.8)	2.38 (60.4)	2.00 (50.8)	3.25 (82.6)
M	2.75 (69.8)	3.00 (76.2)	3.00 (76.2)	4.19 (106.4)
N	3.22 (81.8)	3.28 (83.3)	3.40 (86.4)	4.00 (101.6)
P	1.81 (46.0)	2.03 (51.6)	2.74 (69.6)	3.18 (80.8)
R	0.34 (8.6)	0.34 (8.6)	0.41 (10.4)	0.41 (10.4)
Travel	0.62 (15.8)	0.69 (17.5)	0.88 (22.4)	1.12 (28.4)

Inches (mm)

M084 Stem Stop, Large Bracket

4-Way

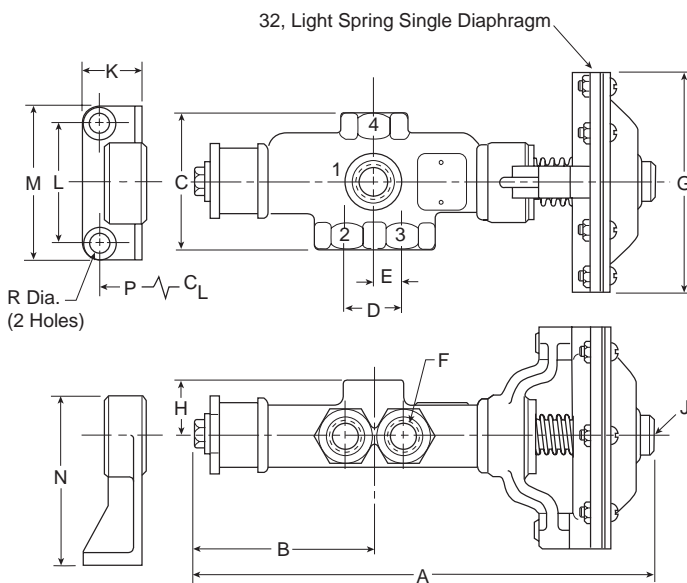

	1/4	3/8	1/2	3/4
A	7.65 (194.3)	8.69 (220.7)	9.82 (249.4)	12.60 (320.0)
B	2.79 (70.9)	3.28 (83.3)	3.89 (98.8)	4.84 (122.9)
C	2.38 (60.4)	2.62 (66.6)	3.12 (79.2)	3.62 (92.0)
D	0.94 (23.9)	1.06 (26.9)	1.25 (31.8)	1.62 (41.2)
E	0.47 (11.9)	0.53 (13.5)	0.62 (15.8)	0.81 (20.6)
F	1/4" Pipe	3/8" Pipe	1/2" Pipe	3/4" Pipe
G	4.34 (110.2)	4.34 (110.2)	4.34 (110.2)	5.27 (133.9)
H	1.00 (25.4)	1.06 (26.9)	1.38 (30.0)	1.50 (38.1)
J	1/8" Pipe	1/8" Pipe	1/8" Pipe	1/8" Pipe
K	1.12 (28.4)	1.12 (28.4)	1.75 (44.4)	2.00 (50.8)
L	2.00 (50.8)	2.38 (60.4)	2.00 (50.8)	3.25 (82.6)
M	2.75 (69.8)	3.00 (76.2)	3.00 (76.2)	4.19 (106.4)
N	3.22 (81.8)	3.28 (83.3)	3.40 (86.4)	4.00 (101.6)
P	2.57 (65.3)	2.95 (74.9)	3.80 (96.5)	4.54 (115.3)
R	0.34 (8.6)	0.34 (8.6)	0.41 (10.4)	0.41 (10.4)
Travel	0.62 (15.8)	0.69 (17.5)	0.88 (22.4)	1.12 (28.4)

Inches (mm)



For inventory, lead times, and kit lookup, visit www.pdnplu.com

Directair 2 & 4 Series
Viking Xtreme Lever Series
42 Lever / Pedal Series
MO Series
Safety
Manual / Mechanical Valves
Brass Poppet / Sliding Seal
Control Panel Products
Sensing

Double Diaphragm Operated

M033 Double Diaphragm

3-Way

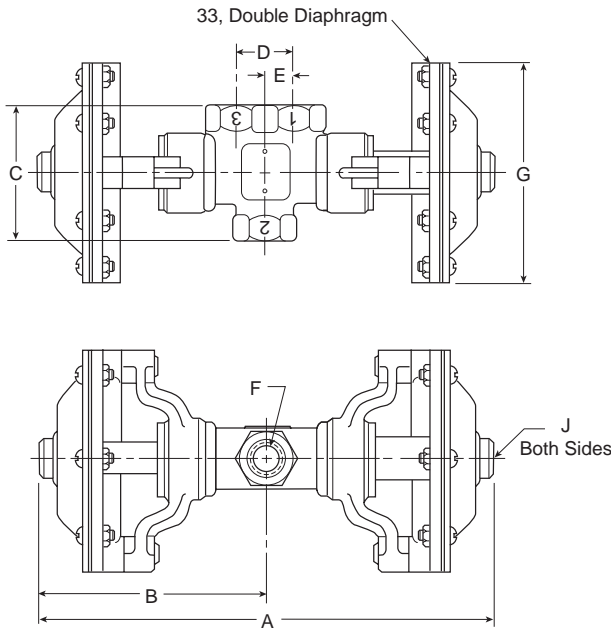

	1/4	3/8	1/2	3/4
A	8.22 (208.8)	8.98 (228.1)	10.40 (264.2)	12.82 (325.6)
B	4.11 (104.4)	4.49 (114.0)	5.20 (132.1)	6.41 (162.8)
C	2.38 (60.4)	2.62 (66.6)	3.00 (76.2)	3.62 (92.0)
D	.94 (23.9)	1.06 (26.9)	1.25 (31.8)	1.62 (41.2)
E	.47 (11.9)	.53 (13.5)	.62 (15.8)	.81 (20.6)
F	1/4" Pipe	3/8" Pipe	1/2" Pipe	3/4" Pipe
G	4.34 (110.2)	4.34 (110.2)	4.34 (110.2)	5.27 (133.9)
J	1/8" Pipe	1/8" Pipe	1/8" Pipe	1/8" Pipe

Inches (mm)

M033 Double Diaphragm

4-Way

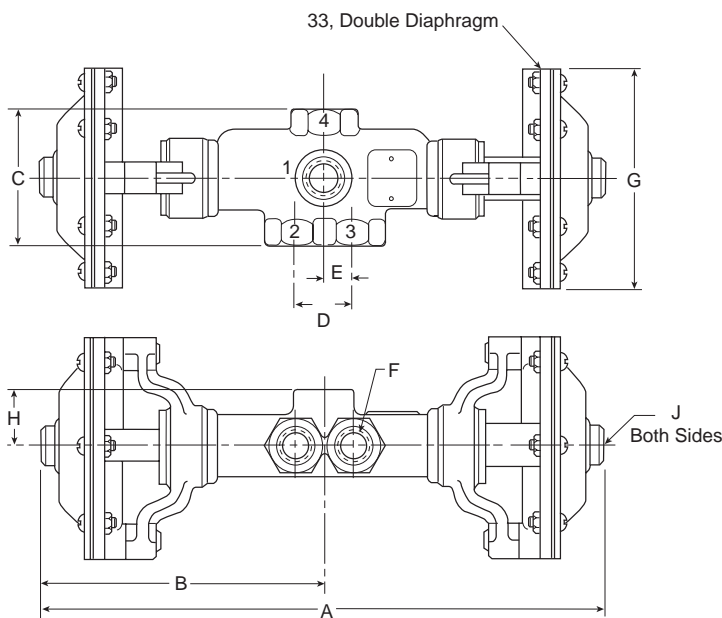

	1/4	3/8	1/2	3/4
A	9.72 (246.9)	10.82 (274.8)	11.86 (301.2)	15.52 (394.2)
B	4.86 (123.4)	5.41 (137.4)	5.93 (150.6)	7.76 (197.1)
C	2.38 (60.4)	2.62 (66.6)	3.12 (79.2)	3.62 (92.0)
D	.94 (23.9)	1.06 (26.9)	1.25 (31.8)	1.62 (41.2)
E	.47 (11.9)	.53 (13.5)	.62 (15.8)	.81 (20.6)
F	1/4" Pipe	3/8" Pipe	1/2" Pipe	3/4" Pipe
G	4.34 (110.2)	4.34 (110.2)	4.34 (110.2)	5.27 (133.9)
H	1.00 (25.4)	1.06 (26.9)	1.38 (30.0)	1.50 (38.1)
J	1/8" Pipe	1/8" Pipe	1/8" Pipe	1/8" Pipe

Inches (mm)



For inventory, lead time, and kit lookup, visit www.pdnplu.com

Directair 2
& 4 Series

Viking Xtreme
Lever Series

42 Lever/
Pedal Series

MO Series

Safety



Manual / Mechanical
Valves

Brass Poppet /
Sliding Seal

Control Panel
Products

Sensing

Dimensional Data

MO Series

Single Cylinder Operated, Spring Return, Stem Stop

M085 Stem Stop, Small Bracket

3-Way

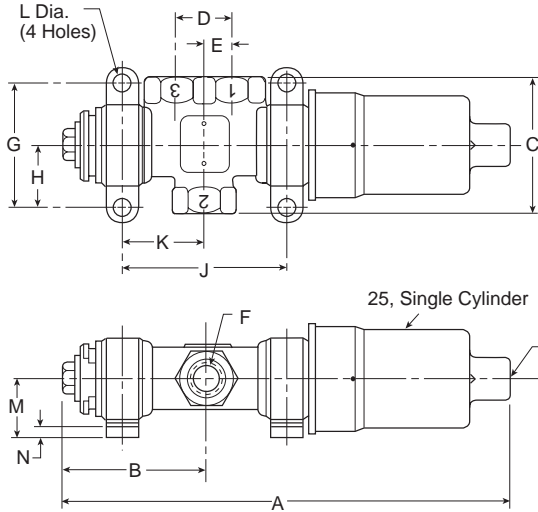

	1/4	3/8	1/2	3/4
A	7.50 (190.5)	8.14 (206.8)	9.03 (229.4)	11.18 (284.0)
B	2.03 (51.6)	2.36 (59.9)	2.83 (71.9)	3.48 (88.4)
C	2.38 (60.4)	2.62 (66.6)	3.00 (76.2)	3.62 (92.0)
D	.94 (23.9)	1.06 (26.9)	1.25 (31.8)	1.62 (41.2)
E	.47 (11.9)	.53 (13.5)	.62 (15.8)	.81 (20.6)
F	1/4" Pipe	3/8" Pipe	1/2" Pipe	3/4" Pipe
G	2.25 (57.2)	2.38 (60.4)	2.62 (66.6)	3.25 (82.6)
H	1.12 (28.4)	1.19 (30.2)	1.31 (33.3)	1.62 (41.2)
J	2.64 (67.1)	3.14 (79.8)	3.73 (94.7)	4.67 (118.6)
K	1.32 (33.5)	1.57 (39.9)	1.87 (47.5)	2.33 (59.2)
L	.34 (8.6)	.34 (8.6)	.41 (10.4)	.41 (10.4)
M	1.12 (28.4)	1.12 (28.4)	1.25 (31.8)	1.56 (39.6)
N	.25 (6.4)	.25 (6.4)	.31 (7.9)	.31 (7.9)
R	1/4" Pipe	1/4" Pipe	1/4" Pipe	1/4" Pipe
Travel	.62 (15.7)	.69 (17.5)	.88 (22.4)	1.12 (28.4)

Inches (mm)

M085 Stem Stop, Small Bracket

4-Way

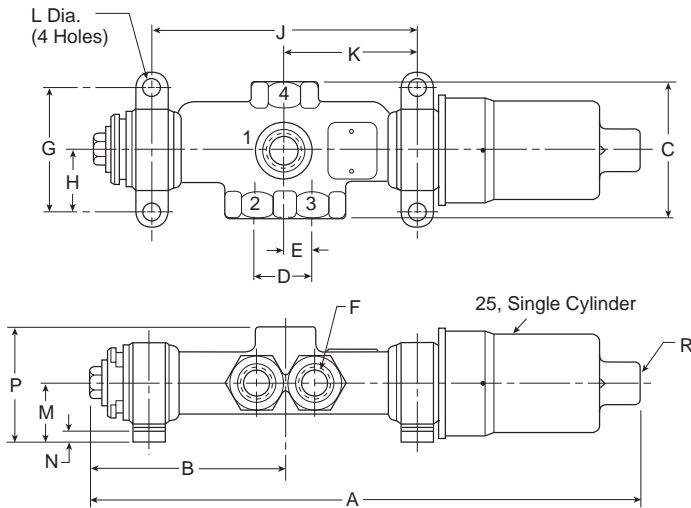

	1/4	3/8	1/2	3/4
A	9.00 (228.6)	9.98 (253.5)	11.15 (283.2)	13.90 (353.1)
B	2.79 (70.9)	3.28 (83.3)	3.89 (98.8)	4.84 (122.9)
C	2.38 (60.4)	2.62 (66.6)	3.12 (79.2)	3.62 (92.0)
D	.94 (23.9)	1.06 (26.9)	1.25 (31.8)	1.62 (41.2)
E	.47 (11.9)	.53 (13.5)	.62 (15.8)	.81 (20.6)
F	1/4" Pipe	3/8" Pipe	1/2" Pipe	3/4" Pipe
G	2.25 (57.2)	2.38 (60.4)	2.62 (66.6)	3.25 (82.6)
H	1.12 (28.4)	1.19 (30.2)	1.31 (33.3)	1.62 (41.2)
J	4.14 (105.2)	4.98 (126.5)	5.85 (148.6)	7.39 (187.7)
K	2.07 (52.6)	2.49 (63.2)	2.92 (74.2)	3.69 (93.7)
L	.34 (8.6)	.34 (8.6)	.41 (10.4)	.41 (10.4)
M	1.12 (28.4)	1.12 (28.4)	1.25 (31.8)	1.56 (39.6)
N	.25 (6.4)	.25 (6.4)	.31 (7.9)	.31 (7.9)
P	2.12 (53.8)	2.18 (55.4)	2.63 (66.8)	3.06 (77.7)
R	1/4" Pipe	1/4" Pipe	1/4" Pipe	1/4" Pipe
Travel	.62 (15.8)	.69 (17.5)	.88 (22.4)	1.12 (28.4)

Inches (mm)



For inventory, lead times, and kit lookup, visit www.pdnplu.com

Directair 2 & 4 Series
Viking Xtreme Lever Series
42 Lever / Pedal Series
MO Series
Safety
Manual / Mechanical Valves
Brass Poppet / Sliding Seal
Control Panel Products
Sensing

Double Cylinder Operated

M019 Double Cylinder

3-Way

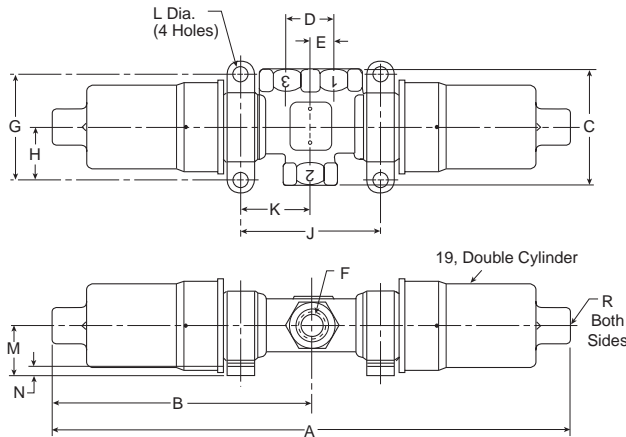

	1/4	3/8	1/2	3/4
A	10.94 (277.9)	11.56 (293.6)	12.40 (315.0)	15.40 (391.2)
B	5.47 (138.9)	5.78 (146.8)	6.20 (157.5)	7.70 (195.6)
C	2.38 (60.4)	2.62 (66.6)	3.00 (76.2)	3.62 (92.0)
D	.94 (23.9)	1.06 (26.9)	1.25 (31.8)	1.62 (41.2)
E	.47 (11.9)	.53 (13.5)	.62 (15.8)	.81 (20.6)
F	1/4" Pipe	3/8" Pipe	1/2" Pipe	3/4" Pipe
G	2.25 (57.2)	2.38 (60.4)	2.62 (66.6)	3.25 (82.6)
H	1.12 (28.4)	1.19 (30.2)	1.31 (33.3)	1.62 (41.2)
J	2.64 (67.1)	3.14 (79.8)	3.73 (94.7)	4.67 (118.6)
K	1.32 (33.5)	1.57 (39.9)	1.87 (47.5)	2.33 (59.2)
L	.34 (8.6)	.34 (8.6)	.41 (10.4)	.41 (10.4)
M	1.12 (28.4)	1.12 (28.4)	1.25 (31.8)	1.56 (39.6)
N	.25 (6.4)	.25 (6.4)	.31 (7.9)	.31 (7.9)
R	1/4" Pipe	1/4" Pipe	1/4" Pipe	1/4" Pipe

Inches (mm)

M019 Double Cylinder

4-Way

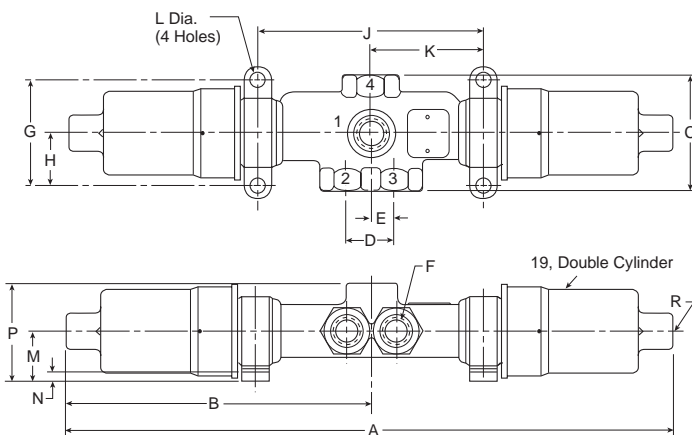

	1/4	3/8	1/2	3/4
A	12.42 (315.5)	13.40 (340.4)	14.52 (368.8)	18.12 (460.2)
B	6.21 (157.7)	6.70 (170.2)	7.26 (184.4)	9.06 (230.1)
C	2.38 (60.4)	2.62 (66.6)	3.12 (79.2)	3.62 (92.0)
D	.94 (23.9)	1.06 (26.9)	1.25 (31.8)	1.62 (41.2)
E	.47 (11.9)	.53 (13.5)	.62 (15.8)	.81 (20.6)
F	1/4" Pipe	3/8" Pipe	1/2" Pipe	3/4" Pipe
G	2.25 (57.2)	2.38 (60.4)	2.62 (66.6)	3.25 (82.6)
H	1.12 (28.4)	1.19 (30.2)	1.31 (33.3)	1.62 (41.2)
J	4.14 (105.2)	4.98 (126.5)	5.85 (148.6)	7.39 (187.7)
K	2.07 (52.6)	2.49 (63.2)	2.92 (74.2)	3.69 (93.7)
L	.34 (8.6)	.34 (8.6)	.41 (10.4)	.41 (10.4)
M	1.12 (28.4)	1.12 (28.4)	1.25 (31.8)	1.56 (39.6)
N	.25 (6.4)	.25 (6.4)	.31 (7.9)	.31 (7.9)
P	2.12 (53.8)	2.18 (55.4)	2.63 (66.8)	3.06 (77.7)
R	1/4" Pipe	1/4" Pipe	1/4" Pipe	1/4" Pipe

Inches (mm)



For inventory, lead time, and kit lookup, visit www.pdnplu.com

Directair 2
& 4 Series

Viking Xtreme
Lever Series

42 Lever/
Pedal Series

MO Series

Safety



Manual / Mechanical
Valves

Brass Poppet /
Sliding Seal

Control Panel
Products

Sensing

Dimensional Data

MO Series

Cam Operated, Spring Return

M095 Direct Acting, Small Bracket (Push Lever)

3-Way

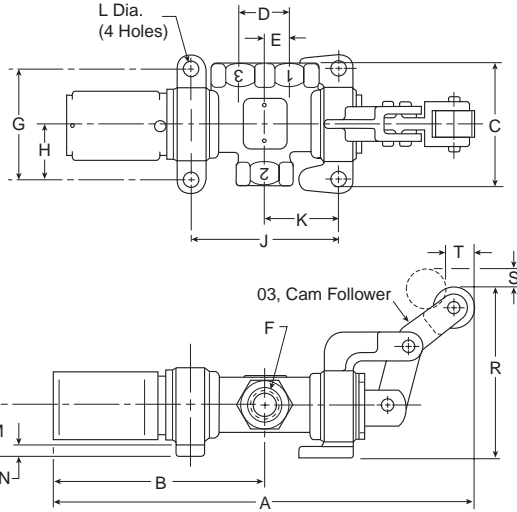

Inches (mm)

	1/4	3/8	1/2	3/4
A	7.98 (202.6)	8.72 (221.5)	10.77 (273.6)	13.54 (343.9)
B	3.92 (99.6)	4.24 (107.7)	5.31 (134.9)	6.92 (175.8)
C	2.38 (60.4)	2.62 (66.6)	3.00 (76.2)	3.62 (92.0)
D	.94 (23.9)	1.06 (26.9)	1.25 (31.8)	1.62 (41.2)
E	.47 (11.9)	.53 (13.5)	.62 (15.8)	.81 (20.6)
F	1/4" Pipe	3/8" Pipe	1/2" Pipe	3/4" Pipe
G	2.25 (57.2)	2.38 (60.4)	2.62 (66.6)	3.25 (82.6)
H	1.12 (28.4)	1.19 (30.2)	1.31 (33.3)	1.62 (41.2)
J	2.63 (66.8)	3.13 (79.5)	3.72 (94.5)	4.56 (115.8)
K	1.31 (33.3)	1.56 (39.6)	1.86 (47.2)	2.28 (57.9)
L	.34 (8.6)	.34 (8.6)	.41 (10.4)	.41 (10.4)
M	1.12 (38.4)	1.12 (28.4)	1.25 (31.8)	1.56 (39.6)
N	.25 (6.4)	.25 (6.4)	.31 (7.9)	.31 (7.9)
R	3.88 (98.6)	3.88 (98.6)	4.23 (107.4)	4.88 (124.0)
S	.43 (10.9)	.47 (11.9)	.70 (17.8)	.67 (17.0)
Travel	.53 (13.5)	.59 (15.0)	.75 (19.0)	.81 (20.6)

M095 Direct Acting, Small Bracket (Push Lever)

4-Way

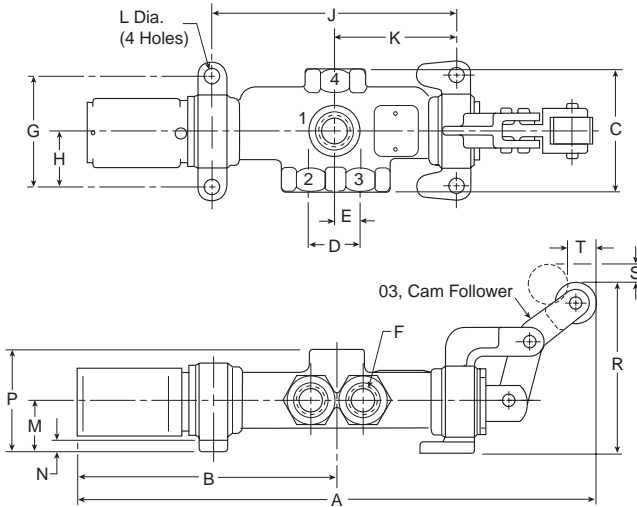

Inches (mm)

	1/4	3/8	1/2	3/4
A	9.48 (204.7)	10.56 (268.2)	12.89 (327.4)	16.26 (413.0)
B	4.67 (118.6)	5.15 (130.8)	5.68 (144.3)	8.27 (210.1)
C	2.38 (60.4)	2.62 (66.6)	3.12 (79.2)	3.62 (92.0)
D	.94 (23.9)	1.06 (26.9)	1.25 (31.8)	1.62 (41.2)
E	.47 (11.9)	.53 (13.5)	.62 (15.8)	.81 (20.6)
F	1/4" Pipe	3/8" Pipe	1/2" Pipe	3/4" Pipe
G	2.25 (57.2)	2.38 (60.4)	2.62 (66.6)	3.25 (82.6)
H	1.12 (28.4)	1.19 (30.2)	1.31 (33.3)	1.62 (41.2)
J	4.14 (105.2)	4.98 (126.5)	5.85 (148.6)	7.39 (187.7)
K	2.07 (52.6)	2.49 (63.2)	2.92 (74.2)	3.69 (93.7)
L	.34 (8.6)	.34 (8.6)	.41 (10.4)	.41 (10.4)
M	1.12 (28.4)	1.12 (28.4)	1.25 (31.8)	1.56 (39.6)
N	.25 (6.4)	.25 (6.4)	.31 (7.9)	.31 (7.9)
P	2.12 (53.8)	2.18 (55.4)	2.63 (66.8)	3.06 (77.7)
R	3.88 (98.6)	3.88 (98.6)	4.23 (107.4)	4.88 (124.0)
S	.43 (10.9)	.47 (11.9)	.70 (17.8)	.67 (17.0)
Travel	.53 (13.5)	.59 (15.0)	.75 (19.0)	.81 (20.6)



For inventory, lead times, and kit lookup, visit www.pdnplu.com

E50

Parker Hannifin Corporation
Pneumatic Division
Richland, Michigan
www.parker.com/pneumatics

Directair 2 & 4 Series
Viking Xtreme Lever Series
42 Lever / Pedal Series
MO Series
Safety
Manual / Mechanical Valves
Brass Poppet / Sliding Seal
Control Panel Products
Sensing

Lever & Treadle Operated, 2-Position Ball Detent

M054 Ball Detent, Small Bracket

3-Way

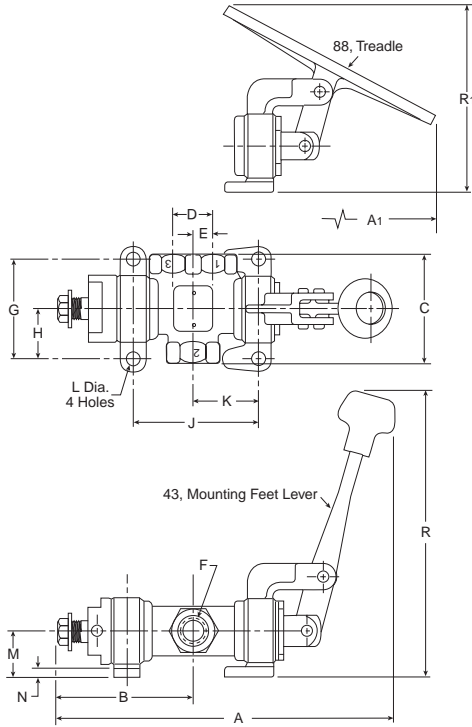

Inches (mm)

	1/4	3/8	1/2	3/4
A	7.35 (186.7)	8.36 (212.3)	9.95 (252.7)	12.25 (311.2)
A1	8.59 (218.2)	9.33 (237.0)	10.65 (270.5)	12.90 (327.7)
B	3.25 (82.6)	3.66 (93.0)	4.39 (111.5)	5.41 (137.4)
C	2.38 (60.4)	2.62 (66.6)	3.00 (76.2)	3.62 (92.0)
D	.94 (23.9)	1.06 (26.9)	1.25 (31.8)	1.62 (41.2)
E	.47 (11.9)	.53 (13.5)	.62 (15.8)	.81 (20.6)
F	1/4" Pipe	3/8" Pipe	1/2" Pipe	3/4" Pipe
G	2.25 (57.2)	2.38 (60.4)	2.62 (66.6)	3.25 (82.6)
H	1.12 (28.4)	1.19 (30.2)	1.31 (33.3)	1.62 (41.2)
J	2.63 (66.8)	3.13 (79.5)	3.72 (94.5)	4.56 (115.8)
K	1.31 (33.3)	1.56 (39.6)	1.86 (47.2)	2.28 (57.9)
L	.34 (8.6)	.34 (8.6)	.41 (10.4)	.41 (10.4)
M	1.12 (28.4)	1.12 (28.4)	1.25 (31.8)	1.56 (39.6)
N	.25 (6.4)	.25 (6.4)	.31 (7.9)	.31 (7.9)
R1	6.78 (172.2)	6.78 (172.2)	8.10 (205.7)	10.73 (272.5)
R2	4.51 (114.6)	4.65 (18.1)	4.85 (123.2)	6.03 (153.2)

M054 Ball Detent, Small Bracket

4-Way

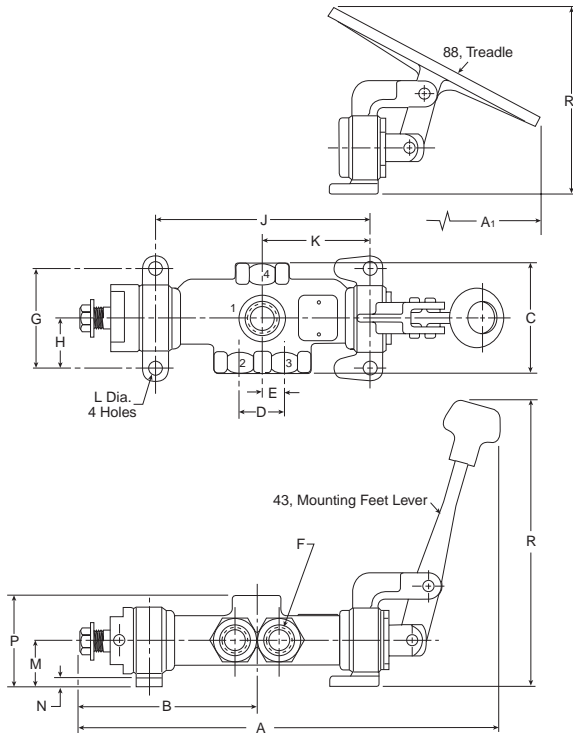

Inches (mm)

	1/4	3/8	1/2	3/4
A	8.86 (225.0)	10.20 (259.1)	11.74 (298.2)	14.96 (380.0)
A1	10.01 (254.2)	11.17 (283.7)	12.77 (324.4)	15.62 (396.8)
B	4.00 (101.6)	4.57 (116.1)	5.44 (138.2)	6.76 (171.7)
C	2.38 (60.4)	2.62 (66.6)	3.00 (76.2)	3.62 (92.0)
D	.94 (23.9)	1.06 (26.9)	1.25 (31.8)	1.62 (41.2)
E	.47 (11.9)	.53 (13.5)	.62 (15.8)	.81 (20.6)
F	1/4" Pipe	3/8" Pipe	1/2" Pipe	3/4" Pipe
G	2.25 (57.2)	2.38 (60.4)	2.62 (66.6)	3.25 (82.6)
H	1.12 (28.4)	1.19 (30.2)	1.31 (33.3)	1.62 (41.2)
J	4.14 (105.2)	4.98 (126.5)	5.85 (148.6)	7.39 (187.7)
K	2.07 (52.6)	2.49 (63.2)	2.92 (74.2)	3.69 (93.7)
L	.34 (8.6)	.34 (8.6)	.41 (10.4)	.41 (10.4)
M	1.12 (28.4)	1.12 (28.4)	1.25 (31.8)	1.56 (39.6)
N	.25 (6.4)	.25 (6.4)	.31 (7.9)	.31 (7.9)
P	2.12 (53.8)	2.18 (55.4)	2.63 (66.8)	3.06 (77.7)
R1	6.78 (172.2)	6.78 (172.2)	8.10 (205.7)	10.73 (272.5)
R2	4.51 (114.6)	4.65 (18.1)	4.85 (123.2)	6.03 (153.2)



For inventory, lead time, and kit lookup, visit www.pdnplu.com

E51

Parker Hannifin Corporation
 Pneumatic Division
 Richland, Michigan
www.parker.com/pneumatics

Directair 2
& 4 Series

Viking Xtreme
Lever Series

42 Lever/
Pedal Series

MO Series

Safety



Manual / Mechanical
Valves

Brass Poppet /
Sliding Seal

Control Panel
Products

Sensing

Features

Parker is protecting your most valuable assets...



Standard 190.147

- This applies to the servicing and maintenance of a machine or equipment.
- Any new, replacement, repair, or renovation to a machine must include an energy isolation device that can accept a lock out device.
- Lock out devices should not be used for any other purposes
- Verification of energy isolation is required



Standard Z244

- This applies to all machines
- Lockout / tagout is the primary method of hazardous energy control
- Machines shall be designed, manufactured, supplied, and installed with energy isolating devices



B11.0
B11.TR6

- B11.0 applies to a broad range of machines, B11.TR6 is specific to machine tools, and B155.1 is specific to packaging and converting machines
- Energy isolating device shall:
 - Be capable of being locked in the OFF position only
 - Be easy to operate
 - Have an exhaust port equal or greater than its supply port
 - Have a pressure indicator that is visible to an operator to verify line is relieved of pressure



B155.1

...By offering the best in pneumatic safety for machine maintenance:



Traditional Ball Valve

- Not a dedicated energy isolation device** ✘
- Not a full exhaust port ✘
- No verification of line exhaust ✘
- Can be locked ON ✘
- Not easily identifiable ✘



Parker Solution

- ✓ Dedicated energy isolation device**
- ✓ Full exhaust port**
- ✓ Verification of line exhaust**
- ✓ Only lockable in OFF position**
- ✓ Easily identifiable**



For inventory, lead times, and kit lookup, visit www.pdnplu.com

Directair 2 & 4 Series
 Viking Xtreme Lever Series
 42 Lever / Pedal Series
 MO Series
 Safety
 Manual / Mechanical Valves
 Brass Poppet / Sliding Seal
 Control Panel Products
 Sensing

LV / LVSS Series

Lockout valves are installed in pneumatic drop legs, or individual pneumatic control lines. In accordance with OSHA procedures, lockout valves are used during maintenance and service procedures of pneumatically (air) operated equipment.

- Used for compliance with OSHA 29 CFR part 1910
- 1/4" to 2" pipe sizes. NPT or BSPP
- Yellow cast aluminum body with red handle or stainless steel (NACE MR0175 / ISO 15156)
- Inline or surface mountable
- Built in port for pressure verification to meet ANSI B11 and PMMI B155 requirements

Material specifications

Description	LV	LVSS
Body:	Cast aluminum alloy	Stainless steel
Handle:	Plastic	Stainless steel
Spool:	Aluminum	Stainless steel
Seals:	Carboxylated nitrile	Carboxylated nitrile
Detent spring:	Stainless steel	Stainless steel
Grease:	Magnalube G [†]	Magnalube G [†]

[†] Trademark Magnalube

Compact

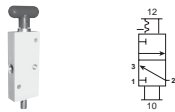

Port in/out	Port exhaust	SCFM in/out	SCFM exhaust	Wt (lb)	Part number *
1/4	3/8	41.8	40.7	0.9	LV2N3B
3/8	3/8	60.7	60.7	0.9	LV3N3B

Standard



Port in/out	Port exhaust	SCFM in/out	SCFM exhaust	Wt (lb)	Part number *
3/8	3/4	107.7	81.1	2.0	LV3N6B
1/2	3/4	161.4	90.9	2.0	LV4N6B
3/4	3/4	187.7	93.2	2.0	LV6N6B
3/4	1-1/4	297.7	204	3.2	LV6NAB
1	1-1/4	375	216	3.2	LV8NAB
1-1/4	1-1/4	436.4	221	3.2	LVANAB

High Flow



Port in/out	Port exhaust	SCFM in/out	SCFM exhaust	Wt (lb)	Part number *
1-1/2	2	761.4	1156	8.2	LVBNCB
2	2	918.2	1186	8.2	LVCNCB

Stainless Steel

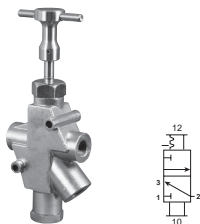

Port in/out	Port exhaust	SCFM in/out	SCFM exhaust	Wt (lb)	Part number *
1/4	1/4	48.6	47.2	3.8	LV2N2BSS
3/8	1/2	131.6	142	6.0	LV3N4BSS
1/2	1/2	124.8	142	6.0	LV4N4BSS
3/4	1	325	386	13	LV6N8BSS
1	1	325	386	13	LV8N8BSS
1-1/2	2	889	1023	35	LVBNCBSS
2	2	889	1023	35	LVCNCBSS

* For BSPP ports, change 4th digit from "N" to "B"

Most popular.



Operating information

Operating pressure:	LV	LVSS
Compact	15 to 145 PSIG	-
Standard	15 to 300 PSIG	15 to 300 PSIG
High flow	15 to 300 PSIG	-
Operating temperature:	40°F to 175°F	30°F to 175°F
Operating media:	Clean, dry, compressed air (5 micron)	



For inventory, lead time, and kit lookup, visit www.pdnplu.com



Features / Part Numbers

EZ Series

The EZ series meets all the same standards as the LV series with the added feature of a soft start when opened. There are still 2 detented positions for the handle (push close, pull to open), but when pulled open, an adjustable needle valve controls the rate of pressure build-up. This can protect equipment during start up after maintenance. The EZ is distinguishable from the LV series by the blue dot on the label.



3/4" Exhaust Shown

Features

- Combines lockout and soft-start functions in a single unit
- Used in systems for compliance with OSHA standard 29 CFR part 1910
- 3/8 Inch to 1-1/4 inch pipe sizes
- Cv's from 3.7 to 13.7
- 3/4 and 1-1/4 inch: exhaust ports available
- Exhaust port threaded for installation of silencer or line for remote exhausting
- Inline or surface mountable
- Yellow cast aluminum body with red handle. Blue dot on body indicates EZ Series valve

Operating information

Operating pressure:	Standard	15 to 300 PSIG
Operating temperature:		40°F to 175°F
Operating media:		Clean, dry, compressed air (5 micron)

Material specifications

Description

Body:	Cast aluminum alloy
Handle:	Plastic
Spool:	Aluminum
Seals:	Carboxylated nitrile
Detent spring:	Stainless steel
Grease:	Magnalube G [†]

† Trademark Magnalube

EZ Series

	Port in/out	Port exhaust	SCFM in/out	SCFM exhaust	Wt (lb)	Part number *
	3/8	3/4	136.4	181	2.1	EZ03NB6
	1/2	3/4	161.4	189	2.1	EZ04NB6
	3/4	3/4	181.9	216	2.1	EZ06NB6
	3/4	1-1/4	272.7	248	3.2	EZ06NBA
	1	1-1/4	311.4	273	3.2	EZ08NBA
	1-1/4	1-1/4	368.2	291	3.2	EZ0ANBA

* For BSPP ports, change 5th digit from "N" to "B"

Most popular.



For inventory, lead times, and kit lookup, visit www.pdnplu.com

Directair 2 & 4 Series
 Viking Xtreme Lever Series
 42 Lever / Pedal Series
 MO Series
 Safety
 Manual / Mechanical Valves
 Brass Poppet / Sliding Seal
 Control Panel Products
 Sensing

Applications

Lockout valves are installed in pneumatic drop legs, or individual pneumatic control lines (see Figure 1). In accordance with OSHA procedures, EZ valves are used during maintenance and service procedures of pneumatically (air) operated equipment. Prior to servicing, the red handle is pressed inward, blocking pressure and relieving all downstream air pressure. A padlock is installed through the locking hasp, preventing accidental actuation during the maintenance procedure. Following maintenance, the padlock is removed and the red handle is pulled outward, gradually returning air pressure to the system. (For complete Lockout / Tagout procedures, consult OSHA Standard 29 CFR Part 1910 in U.S. Federal Register/Vol. 54 No. 169, Friday, September 1, 1989 / Page 36644.)

LV / LVSS Operation

Normal Machine Operation – Valve Open

With the handle pulled outward. Inlet Port 1 is open to outlet Port 2. Exhaust Port 3 is blocked.

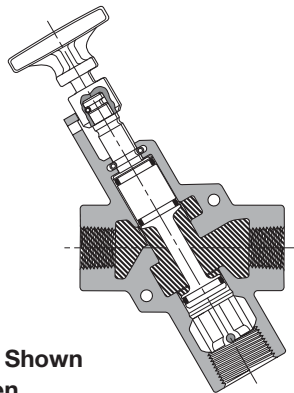

LV Series Shown Open

Mounting

Valves can be inline mounted or surface mounted using the two mounting holes provided in the valve body. Mount valves in plain view with the handle oriented for accessibility.

Placement of Lockout Device

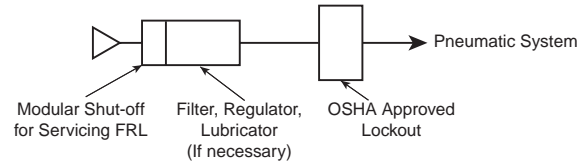
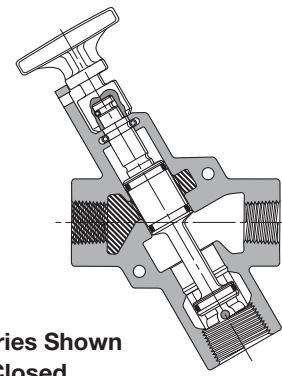

Figure 1.

Lockout Operation – Valve Closed

With the handle pushed inward. Inlet Port 1 is blocked. Outlet Port 2 is open to Exhaust Port 3.



LV Series Shown Closed

EZ Operation

Normal Machine Operation – Valve Open

When the red handle is pulled outward, the adjustable needle valve (accessed through the top of the handle) setting determines the rate of pressure buildup. When downstream pressure reaches the full flow described in the specifications below, Inlet Port 1 is open to outlet Port 2. Exhaust Port 3 is blocked.

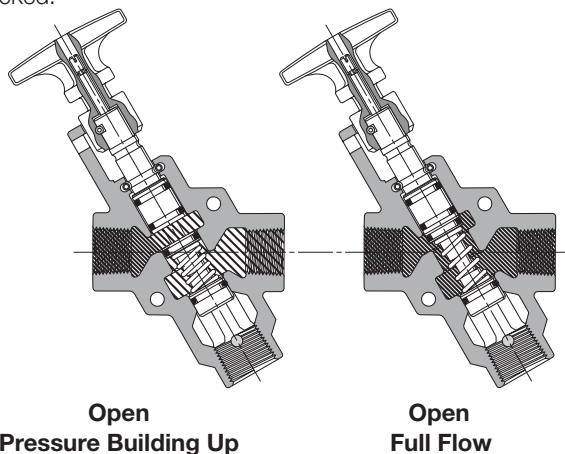

Open Pressure Building Up

Open Full Flow

Lockout Operation – Valve Closed

When the red handle is pushed inward, the Inlet Port 1 is blocked. Downstream air is exhausted through Exhaust Port 3.

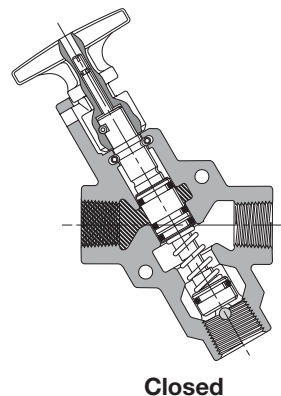

Closed



For inventory, lead time, and kit lookup, visit www.pdnplu.com

Directair 2 & 4 Series
Viking Xtreme Lever Series
42 Lever / Pedal Series
MO Series
Safety
Manual / Mechanical Valves
Brass Poppet / Sliding Seal
Control Panel Products
Sensing

Accessories

Corrosion resistant mufflers for harsh environments



Port size	Construction	Threads	Dimensions In. (mm)		Part number
			Width	Length	
1/4	Stainless steel	Male, NPT	0.56 (14.2)	1.75 (44.5)	5500A2004
1/2	Stainless steel	Male, NPT	0.87 (22.1)	2.75 (69.7)	5500A4004
1	Stainless steel	Male, NPT	1.31 (33.3)	3.87 (98.3)	5500B6004
2	Nickel plated	Male, NPT	2.37 (60.2)	5.50 (139.7)	5500A9004*

* Nickel plated

High Flow Silencers



Part number *	ES25MC	ES37MC	ES50MC	ES75MC	ES100MC	ES125MC	ES150MC	ES200MC
Pipe size	1/4	3/8	1/2	3/4	1	1-1/4	1-1/2	2
Flow (scfm)	129	219	549	893	1013	1486	1580	1580
Hex In. (mm)	0.63 (16)	1.00 (25)	1.00 (25)	1.62 (41)	1.62 (41)	—	—	2.99 (76)
Length In. (mm)	1.85 (47)	3.31 (84)	3.31 (84)	4.56 (116)	4.56 (116)	5.69 (145)	5.69 (145)	7.68 (195)

* NPT ports standard, for BSPT ports, add a "B" after the "S"

Pop-up Pressure Indicator



Brass – Part # **988A30** – Can be used on all LV or EZ series to provide visual verification of line exhaust



Stainless – Part# **1155H30** – Can be used on SS LV series to provide visual verification of line exhaust

Pressure Switch



- Part # **PPS1-2C3-RHM** (DIN 9.4mm connector)
- Part # **PPS1-2C3-RWL** (18" leads)
- Signal verification of line exhaust
- Field adjustable set point

Directair 2 & 4 Series
 Viking Xtreme Lever Series
 42 Lever / Pedal Series
 MO Series
 Safety
 Manual / Mechanical Valves
 Brass Poppet / Sliding Seal
 Control Panel Products
 Sensing

LZ Series, Exhaust Port - Compact, Standard, High Flow

Compact

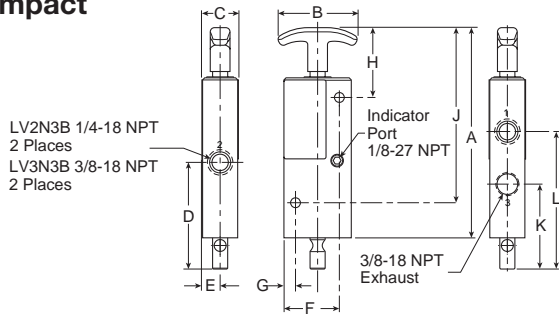

Compact LV Series, 3/8" Exhaust Port Dimensions

A	B	C	D	E	F
6.50 (165)	2.25 (57)	1.05 (27)	3.04 (77)	.51 (13)	1.58 (40)
G	H	J	K	L	
.33 (8)	1.99 (51)	4.99 (127)	2.42 (62)	3.92 (100)	

Inches (mm)

Standard

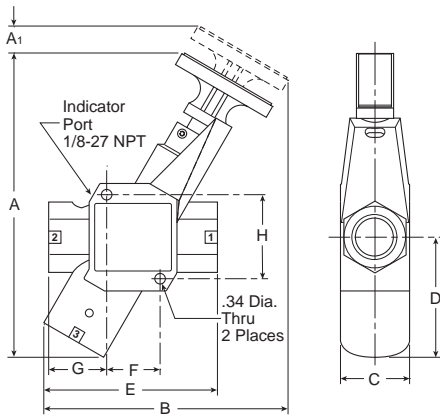

Compact LV Series, 3/4" Exhaust Port Dimensions

A	A ₁	B	C	D	E
8.32 (211)	0.64 (16)	6.60 (168)	2.00 (51)	3.06 (78)	4.24 (108)
F	G	H			
1.32 (111)	1.56 (40)	2.21 (56)			

Inches (mm)

Compact LV Series, 1-1/4" Exhaust Port Dimensions

A	A ₁	B	C	D	E
9.91 (252)	0.85 (22)	7.95 (202)	2.25 (57)	3.91 (99)	5.65 (144)
F	G	H			
1.74 (44)	1.89 (48)	2.74 (70)			

Inches (mm)

High Flow

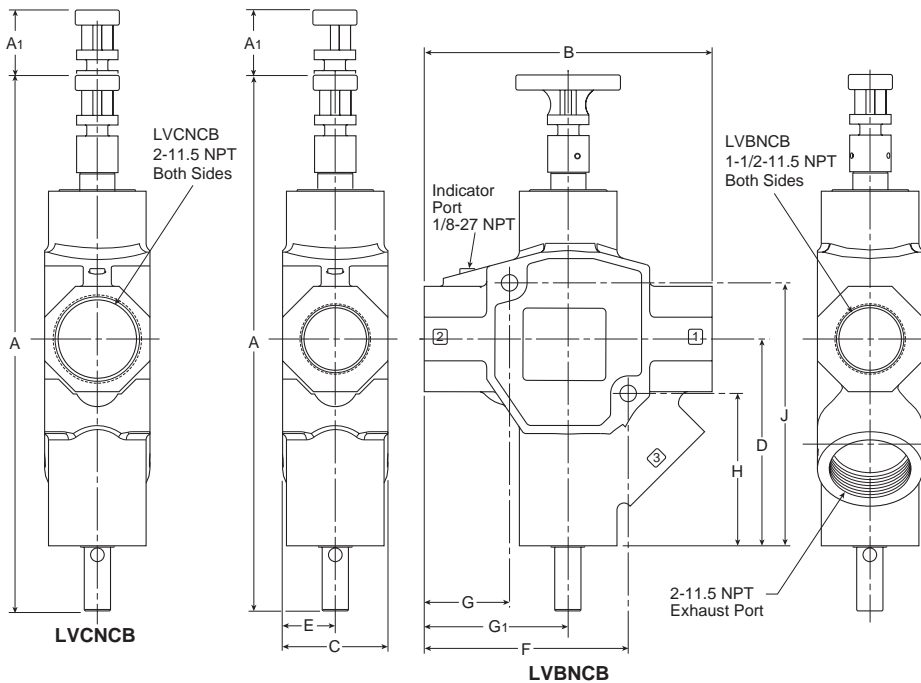

High Flow LV Series, 2" Exhaust Port Dimensions

A	A ₁	B
14.82 (376)	1.87 (47)	8.20 (208)
C	D	E
3.00 (76)	5.89 (150)	1.50 (38)
F	G	G ₁
5.81 (148)	2.43 (62)	4.10 (104)
H	J	
4.34 (110)	7.49 (190)	

Inches (mm)



For inventory, lead time, and kit lookup, visit www.pdnplu.com



Dimensional Data

LV Lockout, Stainless Steel

LZ Series, Exhaust Port - Compact, Standard, High Flow

Stainless Steel

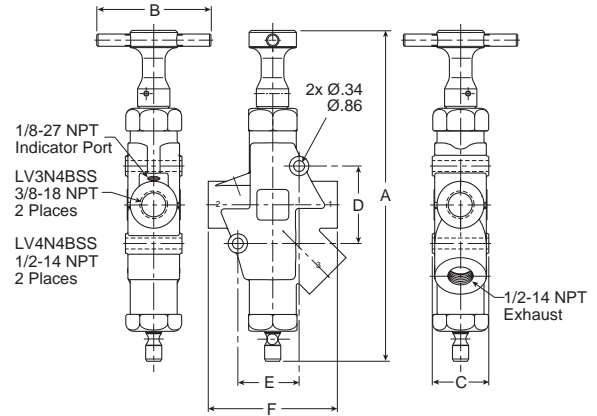
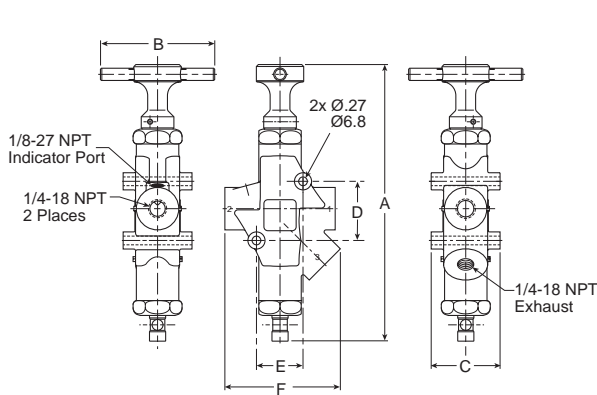

Stainless Steel LV Series, 1/4" Exhaust Port Dimensions

A	B	C	D	E	F
8.47	3.50	2.11	1.81	1.43	3.54
(215)	(89)	(54)	(46)	(36)	(90)

Inches (mm)

Stainless Steel LV Series, 1/2" Exhaust Port Dimensions

A	B	C	D	E	F
10.24	3.50	1.75	2.40	190	4.00
(260)	(89)	(45)	(61)	(48)	(102)

Inches (mm)

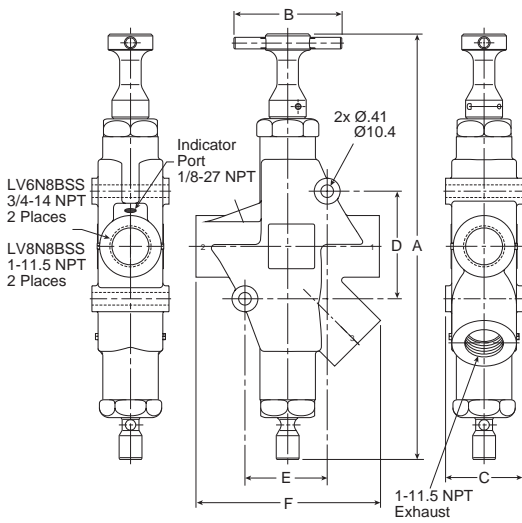

Stainless Steel LV Series, 1" Exhaust Port Dimensions

A	B	C	D	E	F
13.80	3.50	2.50	3.49	2.67	5.99
(351)	(89)	(64)	(89)	(68)	(152)

Inches (mm)

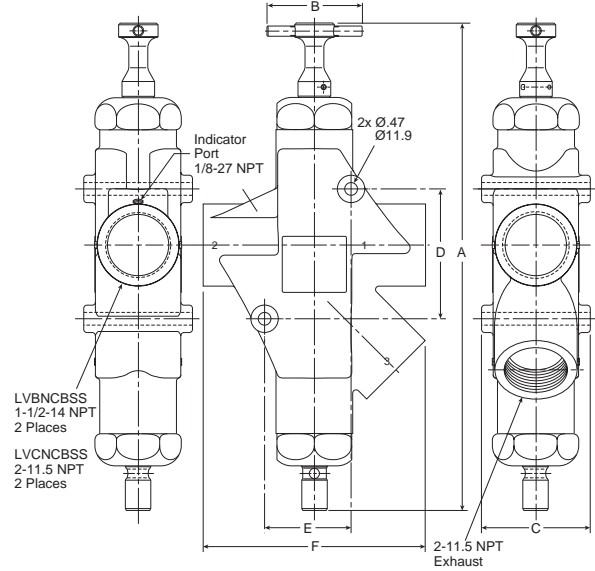

Stainless Steel LV Series, 2" Exhaust Port Dimensions

A	B	C	D	E	F
17.92	3.50	4.00	4.77	3.18	8.16
(455)	(89)	(102)	(121)	(81)	(207)

Inches (mm)



For inventory, lead times, and kit lookup, visit www.pdnplu.com

Directair 2 & 4 Series
 Viking Xtreme Lever Series
 42 Lever / Pedal Series
 MO Series
 Safety
 Manual / Mechanical Valves
 Brass Poppet / Sliding Seal
 Control Panel Products
 Sensing

EZ Series, Exhaust Port - Standard Flow

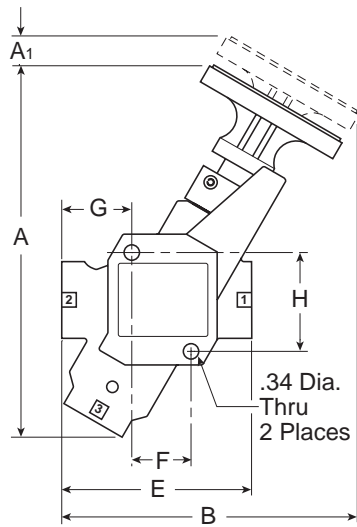

EZ 3/4" Exhaust Port Dimensions

A	A1	B	C	D
8.32 (211)	0.64 (16)	6.60 (168)	2.00 (51)	3.06 (78)

E	F	G	H
4.24 (108)	1.32 (111)	1.56 (40)	2.21 (56)

Inches (mm)

EZ 1-1/4" Exhaust Port Dimensions

A	A1	B	C	D
9.91 (252)	0.85 (22)	7.95 (202)	2.25 (57)	3.91 (99)

E	F	G	H
5.65 (144)	1.74 (44)	1.89 (48)	2.74 (70)

Inches (mm)

Directair 2
& 4 Series

Viking Xtreme
Lever Series

42 Lever/
Pedal Series

MO Series

Safety



Manual / Mechanical
Valves

Brass Poppet /
Sliding Seal

Control Panel
Products

Sensing



For inventory, lead time, and kit lookup, visit www.pdnplu.com

Features

Two-Hand Controls

Two-Hand Controls

- The pre-assembled two-hand control enclosure occupies both hands of an operator by requiring nearly simultaneous operation of two pushbuttons
- Poppet – snap-acting (no spools)
- Same air as in cylinders – Filtration: 40 micron
- No lubrication required



Part number	Connection
PXPC111	5/32" Instant

Operation

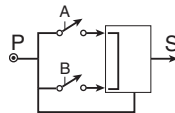

- Output “S” will appear only if “A” and “B” are simultaneously operated (within .5 seconds or less of each other).
- If the operator actuates only one pushbutton, either “A” or “B”, or if both “A” and “B” are actuated but at an interval greater than .5 seconds, output “S” will not appear.
- Output “S” is regenerated by supply “P”. Output “S” will therefore disappear if supply “P” is cut off.
- Output “S” will disappear if either “A” or “B” is released.
- If output “S” disappears for any reason, “A” and “B” must be nearly simultaneously actuated to again provide output “S”.
- Since output “S” is regenerated it appears sharply, at full force (snap-acting), and is quickly exhausted upon deactivation. In addition the module is not affected by the length or diameter of tubing used for output “S”.

General Characteristics

Operating Pressure	40 to 120 PSI (3 to 8 bar)
Permissible Fluids –	Air or neutral gas 40 micron filtration, lubricated or dry
Flow at 90 PSI (6 bar)	7 SCFM (200 l/mn ANR)
Operating Temperature	-5°F to 140°F (-15°C to 60°C)
	Below 40°F (5°C), an air dryer is required
Storage Temperature	-40°F to 160°F (-40°C to 70°C)
Number of operations with dry air at 90 PSI (6 bar), 68°F (20°C), frequency 1 Hz	1 Million Operations
Vibration resistance –	Conforms to section 19-2 of bureau Véritas regulations (November 1987)
Materials –	Body Glass Filled Nylon
	Operating Head Zinc Alloy and Plastic
Connections:	5/32" instant

Mounting

Approvals:

- In accordance with European Standard EN 574 - September 1996
- Conforms to the model that has obtained CE Type Test Certificate No. 02526 520 4631 0397

! WARNING

These devices should **NOT** be used in any application involving rotary clutch presses. Two hand control modules do not of themselves insure the safety of any machine. Users and original equipment manufacturers are responsible for making sure that installations meet all relevant safety regulations.

Notes: These two-hand control modules provide an output signal upon nearly concurrent operation of two pushbuttons.

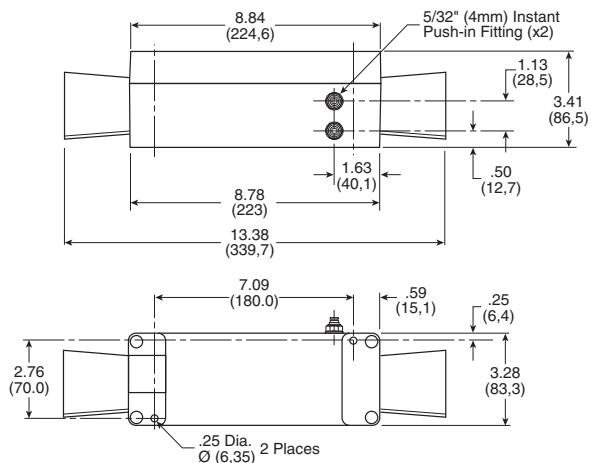

Inches (mm)



For inventory, lead times, and kit lookup, visit www.pdnplu.com

Directair 2 & 4 Series

Viking Xtreme Lever Series

42 Lever / Pedal Series

M0 Series

Safety



Manual / Mechanical Valves

Brass Poppet / Sliding Seal

Control Panel Products

Sensing

Two-Hand Control Module

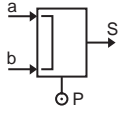

PXPA11

S = Output
 AdB = Momentary input
 P = Pressure supply

Part number	Connection
PXPA11	5/32" Instant

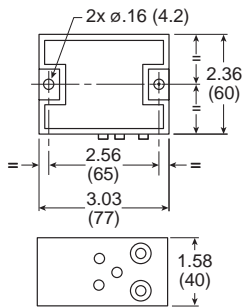

Specifications

Air Quality –	Standard Shop Air, Lubricated or Dry	40 µm Filtration
Materials –	Body	Polyamide
	Operating Head	Zinc Alloy & Plastic
Flow at 90 PSI (6 bar) in SCFM (l/mn ANR)		7 (200)
Number of Operations with Dry Air at 90 PSI (6 bar) and 68°F (20°C) - Frequency 1 Hz		1 million Operations
Operating Positions		All Positions
Operating Pressure –		15 to 115 PSIG (1 to 8 bar)
Ports	5/32" Instant for Semi-Rigid Nylon or Polyurethane Tube	
Operating Temperature –	Operating	32°F to 122°F (0°C to 50°C)
	Storage	-22°F to 140°F (-30°C to 60°C)
Vibration resistance:	Conforms to section 19-2 of bureau Véritas regulations (November 1987)	

⚠ WARNING

These devices should **NOT** be used in any application involving rotary clutch presses. Two hand control modules do not of themselves insure the safety of any machine. Users and original equipment manufacturers are responsible for making sure that installations meet all relevant safety regulations.

Notes: These two-hand control modules provide an output signal upon nearly concurrent operation of two pushbuttons.

Two-Hand Control Module Guard

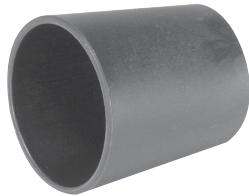

PPRL15

Part number	Base component
PPRL15	PXPC111

Two Hand Repair Parts

Part number	Quantity required	Description
PXPA11	1	Control Module
PXBB4931	2	Valve Body & Mounting Ring
ZB4BR*	2	Push Button
PPRL15	2	Control Module Guard

* 2 = Black, 3 = Green, 4 = Red



For inventory, lead time, and kit lookup, visit www.pdnplu.com

Features / Part Numbers

PL-VL Series Valves

PL / VL Series

These are 4-Way, 3-Position, rotary disc, direct-operated air valves. Two different types of control are offered. The forged bronze disc and the cast iron surface upon which the disc works are ground and lapped to provide a leak-proof seal. Air pressure from the inlet port is confined beneath the disc, making the seal tighter as the pressure increases, yet friction between the lapped surfaces is so low that only 15 pounds of force is required to move the lever at 100 PSI line pressure. The need for packing to seal around the stem is eliminated.



Valve can be furnished for gasketing to a manifold on customer's machine or with an adaptor for tapped bottom porting.

Valves are detented.

Operating handles may be installed in any of four positions.

Operating information

Operating pressure: 0 to 150 PSI (0 to 1035 kPa)

Temperature range: 18°F to 200°F (-8°C to 93°C)

Lubrication: Filtered and lubricated air recommended for maximum valve life and minimum maintenance.

PL Series Valves

This type has a 90° lever movement. In neutral position, inlet is closed to pressure – outlets closed to exhaust. With clockwise (CW), inlet is connected to cylinder port directly opposite. Other cylinder port is connected to exhaust. With counterclockwise (CCW), inlet is connected to cylinder port diagonally opposite. Other cylinder port is connected to exhaust. Recommended for stationary air cylinders, arbor presses, and as a throttling valve for positioning air cylinders.

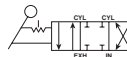

Port Size	Description	Cv	Part number	Optional Bottom Port Adapter	Optional Bottom Manifold
1/4" NPT	4-way, 3-position, detent, closed center	2.5	PL25	PLD25	PLA25
3/8" NPT	4-way, 3-position, detent, closed center	3.0	PL37	PLD37	PLA37
1/2" NPT	4-way, 3-position, detent, closed center	6.2	PL50	PLD50	PLA50

VL Series Valves

This type has a 90° lever movement. In neutral position, inlet is closed to pressure – outlets open to exhaust. With clockwise (CW), inlet is connected to cylinder port directly opposite. Other cylinder port is connected to exhaust. With counterclockwise (CCW), inlet is connected to cylinder port diagonally opposite. Other cylinder port is connected to exhaust. This valve is particularly suited for pneumatic chuck operation.

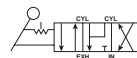

Port Size	Description	Cv	Part number	Optional Bottom Port Adapter	Optional Bottom Manifold
1/4" NPT	4-way, 3-position, detent, exhaust center	2.5	VL25	VLD25	VLA25
3/8" NPT	4-way, 3-position, detent, exhaust center	3.0	VL37	VLD37	VLA37
1/2" NPT	4-way, 3-position, detent, exhaust center	6.2	VL50	VLD50	VLA50

Optional Items and Accessories

Bottom Porting for gasket mounting to customer's manifold. Four holes are drilled (see following page for dimensions) through the base into the four port chambers. Side ports are plugged. Customer provides suitable means of gasketing. Specify Series PLA or VLA.

Bottom Ported Adaptor Plate, o-ring gasketed to base (four o-rings furnished). Adaptor plate has four drilled and tapped ports. Side ports are plugged. Specify Series PLD or VLD.

Service kits

Description	Valve size	Part number
Lever assembly service kits	PL25, PL25HP, PL37, PL37HP, VL25, & VL37	PL2425P
	PL50, PL50HP & VL50	PL2424P
Body gasket	PL25, PL25HP, PL37, PL37HP, VL25, & VL37	P66837
	PL50, PL50HP & VL50	P66829

Most popular.



For inventory, lead times, and kit lookup, visit www.pdnplu.com

Directair 2 & 4 Series

Viking Xtreme Lever Series

422 Lever / Pedal Series

MO Series

Safety



Manual / Mechanical Valves

Brass Poppet / Sliding Seal

Control Panel Products

Sensing

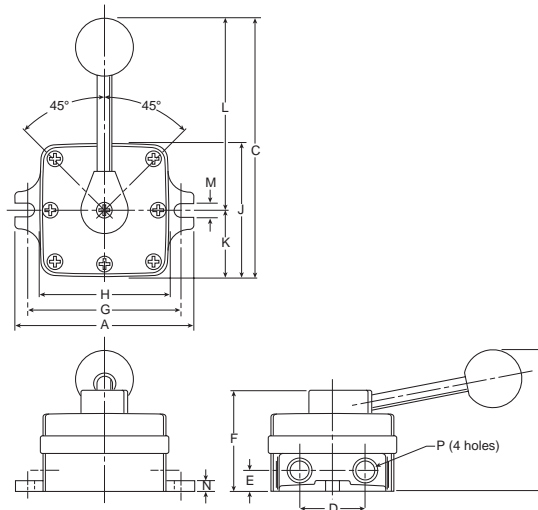

PL-VL Dimensions

	A	B	C	D	E	F	G	H	J	K	L	M	N	P
PL25	4.75	3.81	6.81	1.69	.56	2.75	4.12	3.50	3.50	1.69	5.06	.34	.28	1/4
VL25	(121)	(97)	(173)	(43)	(14)	(70)	(105)	(89)	(89)	(43)	(129)	(9)	(7)	NPT
PL37	4.75	3.81	6.81	1.69	.56	.56	4.12	3.50	3.50	1.69	5.06	.34	.28	3/8
VL37	(121)	(97)	(173)	(43)	(14)	(14)	(105)	(89)	(89)	(43)	(129)	(9)	(7)	NPT
PL50	5.62	4.44	8.94	2.12	.66	3.25	5.00	4.38	4.38	2.12	6.75	.34	.34	1/2
VL50	(143)	(113)	(227)	(54)	(17)	(83)	(127)	(111)	(111)	(54)	(171)	(9)	(9)	NPT

inches (mm)

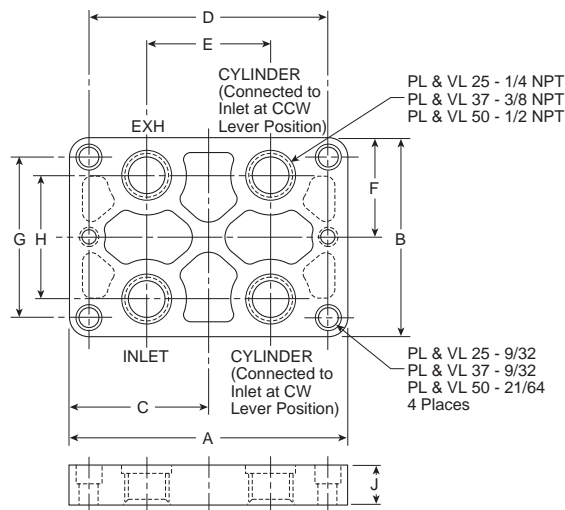

Adapter Plate for Series PLD and VLD Dimensions

	A	B	C	D	E	F	G	H	J
PLD25	4.75	3.38	2.38	4.12	2.19	1.69	2.75	2.06	.58
VLD25	(121)	(86)	(60)	(105)	(56)	(43)	(70)	(52)	(15)
PLD37	4.75	3.38	2.38	4.12	2.19	1.69	2.75	2.06	.58
VLD37	(121)	(86)	(60)	(105)	(56)	(43)	(70)	(52)	(15)
PLD50	5.62	4.25	2.81	5.00	2.59	2.12	3.62	2.81	.70
VLD50	(143)	(108)	(71)	(127)	(66)	(54)	(92)	(71)	(18)

inches (mm)



For inventory, lead time, and kit lookup, visit www.pdnplu.com

Directair 2
& 4 Series

Viking Xtreme
Lever Series

42 Lever/
Pedal Series

M0 Series

Safety



Manual / Mechanical
Valves

Brass Poppet /
Sliding Seal

Control Panel
Products

Sensing

Features / Part Numbers

HV Valve Series

HV Valve Series

- Compact and simple design
- Rotary disc, direct operated valves
- Side porting
- Detent action smooth lever actuation
- General pneumatic applications



Material specifications

Cover	Zinc
Body	Aluminum
Seals	Polyurethane

Operating information

Operating pressure: 0 to 150 PSI (0 to 10 bar)
 Temperature range: 32°F to 166°F (0°C to 60°C)
 Lubrication: Filtered and lubricated air recommended for maximum valve life and minimum maintenance.

HV Series Valves

These closed center valves have a 90° lever movement. In neutral position, the inlet is closed to pressure and outlets are closed to exhaust. With clockwise (CW) rotation, inlet (IN) is connected to C2, C1 is connected to exhaust (EXH). With counter-clockwise (CCW) rotation, inlet (IN) is connected to C1, C2 is connected to exhaust (EXH). These valves are recommended for stationary air cylinders, and as throttling valves for positioning air cylinders. They are not to be used on punch presses or press brakes.

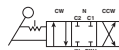

Port size	Description	Cv (ANSI)	Cv (JIS)	Part number
1/4" NPT	4-way, 3-position	0.5	0.4	HVN4200-8
3/8" NPT	4-way, 3-position	1.4	2.72	HVN4400-10
1/2" NPT	4-way, 3-position	1.5	3.26	HVN4400-15

HVN4200-8

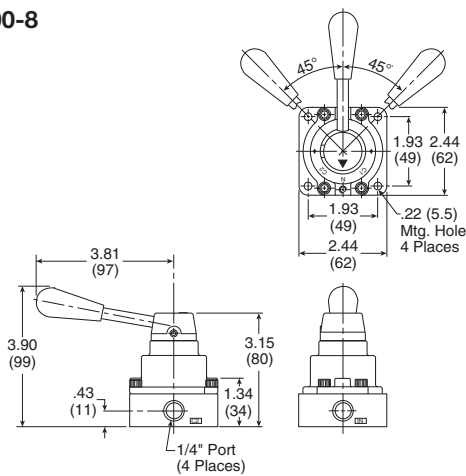

HVN4400-10, 15

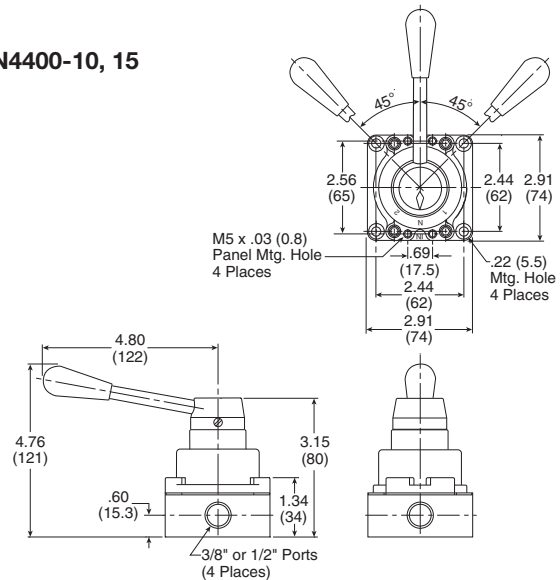

Service kits

Description	Valve size	Part number
Disk & seal service kits	HV4200	HVRK420001
	HV4400	HVRK440001

ANSI Cv vs. JIS Cv

For Pneumatic Valve flow, the measurement Cv – Coefficient of Flow – is used to convey to the user how much air can flow through a given valve. Most valve manufacturers publish this information in their catalogs to assist the user in choosing the proper valve for their application. In publishing this data however, there are discrepancies in how the Cv is calculated, resulting in some Cv's being OVERSTATED by 20 to 40%. This can adversely affect the user's application because the valve flows LESS than the published Cv.

The reason for the large discrepancy is in the method of calculation - the ANSI (NFPA) or the JIS standard. Parker's Cv valve is calculated using the ANSI (NFPA) T3.21.3-1990 standard. The ANSI (NFPA) method is a structured test using very specific tube sizes and lengths, inlet pressures and pressure drops, and volume chambers.

Most popular.



For inventory, lead times, and kit lookup, visit www.pdnplu.com

Hand Operated Sliding Seal Valves

Sliding seal valves provide 3 or 4-Way directional control in a compact body size. Comfortable hand lever is easy to operate and maintains set position. Disc type valve has minimum number of moving parts. Valves should be used with filtered and lubricated air.

CAUTION:
Install guards on all hand operated valves.
Accidental operation can cause personal injury.

Material specifications

Internal components	Brass, stainless steel
Body	Die cast zinc
Seals	Buna N

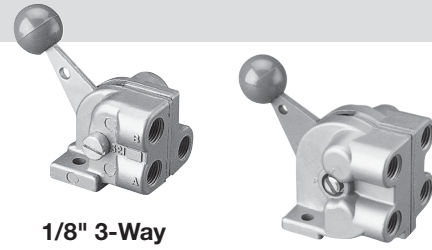

1/8" 3-Way

1/4" 4-Way

Operating information

Operating pressure: Max. 200 PSIG air only
Min. 26" Hg vacuum

Temperature range: -40°F to 212°F (-40°C to 100°C)
(If it is possible that the ambient temperature may fall below freezing, the medium must be moisture free to prevent internal damage or unpredictable behavior.)

Hand Operated Sliding Seal Valve

Symbol	Port size	Function	Cv (Avg)	Service kit*	Part number
	1/8"	3-way, 2-position, detented	0.54	032130899	032130599
	1/8"	4-way, 2-position, detented	0.54	032130899	032140299
	1/4"	3-way, 2-position, detented	1.25	008230299	008230109
	1/4"	4-way, 3-position, detented, center blocked	1.25	008230299	008240109

Note: 3-Way exhaust passage is through an untapped hole in bottom side of valve.

1/8" 3-Way 032130599

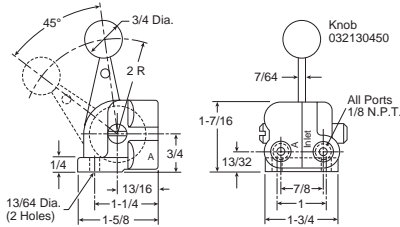

Service Kit 032130899*

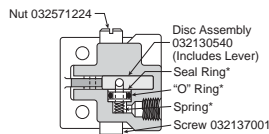

1/8" 4-Way 032140299

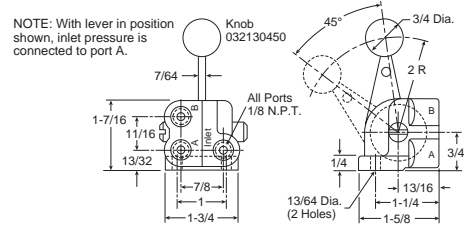

Service Kit 032130899*

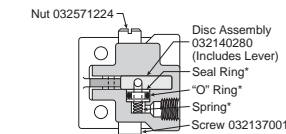

1/4" 3-Way 008230109

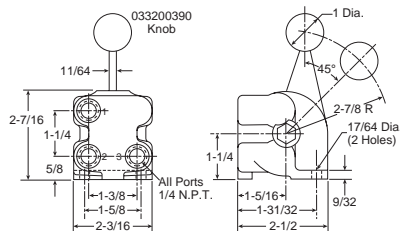

Service Kit 032130899*

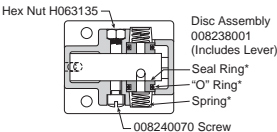

1/4" 4-Way 008240109

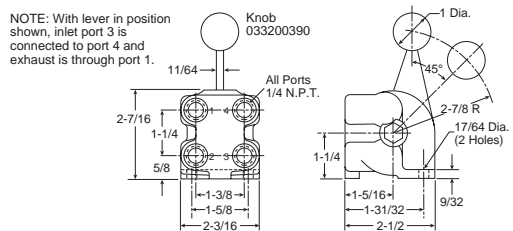

Service Kit 032130899*

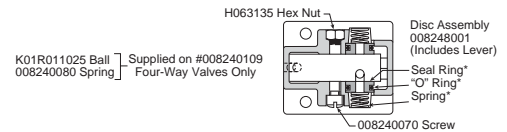

Most popular.

* Service kits contain asterisk items



For inventory, lead time, and kit lookup, visit www.pdnplu.com

Directair 2
& 4 Series

Viking Xtreme
Lever Series

42 Lever/
Pedal Series

M0 Series

Safety



Manual / Mechanical
Valves

Brass Poppet /
Sliding Seal

Control Panel
Products

Sensing

Features / Part Numbers

Button Operated Valves

2 & 3-way normally closed poppet, 1/4" Port valve operates at the press of a button and may be installed in a pipe line or used as a portable blow gun attached to a length of hose.

CAUTION:
 Install guards on all hand operated valves.
 Accidental operation can cause personal injury.

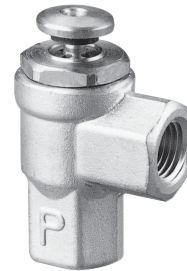



Material specifications

Internal components	Brass, stainless and plated steel
Body	Brass
Seals	Buna N

Operating information

Operating pressure:	Max. 150 PSIG air only Min. 0 PSIG
Temperature range:	-20°F to 180°F (-28°C to 82°C)

Button Operated Valves

	Port size	Function	Cv (Avg)	Old number	Service kit	Part number
	1/4"	2-way	0.94	7796SP1	077960105	077960199
	1/4"	3-way	0.94	8187	077960105	081870129

Dimensions

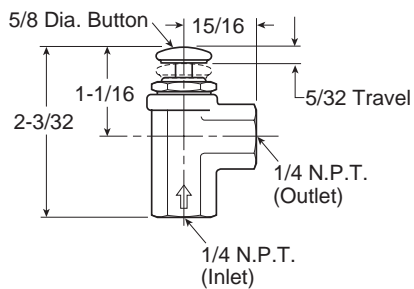

Replacement Parts

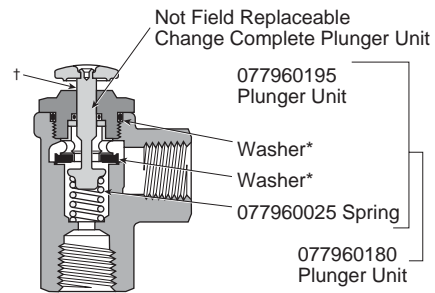

† 077960199 2-Way valve shown.
 * Included in service kits listed above.



For inventory, lead times, and kit lookup, visit www.pdnplu.com

Directair 2 & 4 Series
 Viking Xtreme Lever Series
 42 Lever / Pedal Series
 MO Series
 Safety
 Manual / Mechanical Valves
 Brass Poppet / Sliding Seal
 Control Panel Products
 Sensing

Hand / Cam Operated Valves

Inline, button-operated, 2 & 3-way normally closed poppet, 1/4" port valve has mounting holes for single or gang mounting. Actuation by hand, cam or mechanical fingers. Valves should be used with filtered and lubricated air.



CAUTION:

Install guards on all hand operated valves. Accidental operation can cause personal injury.

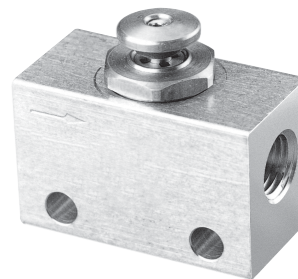

Operating information

Operating pressure: Max. 150 PSIG air only
Min. 0 PSIG
Temperature range: -20°F to 180°F (-28°C to 82°C)

Hand / Cam Operated Valves

	Port size	Function	Cv (Avg)	Old number	Service kit	Part number
	1/4"	2-way	0.94	7796SP5	077960105	077960319
	1/4"	3-way	0.94	8187SP1	077960105	081870139

Replacement Parts

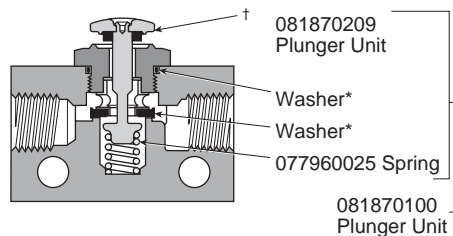
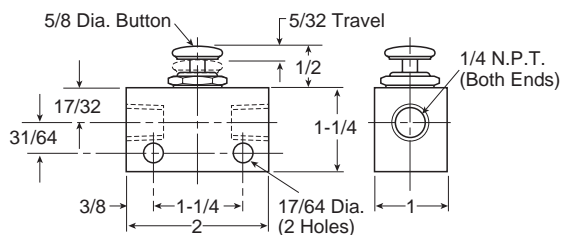

† 081870139 3-Way valve shown.
* Included in service kits listed above.



For inventory, lead time, and kit lookup, visit www.pdnplu.com

Directair 2 & 4 Series
Viking Xtreme Lever Series
42 Lever / Pedal Series
MO Series
Safety
Manual / Mechanical Valves
Brass Poppet / Sliding Seal
Control Panel Products
Sensing

Features / Part Numbers

Bleed Valves

This 2-way normally closed bleeder valve is an accessory that may be used with any double pilot-operated valve (bleed type). It provides manual or cam-operated control. A 1/4" pipe thread fits either the pilot valve port or the feeder airline. Opposite end has standard 1/2-20 thread for easy mounting on machine or panel. Valves should be used with filtered and lubricated air.



Material specifications

Internal components	Brass, stainless steel
Body	Brass
Seals	Fluorocarbon

Operating information

Operating pressure:	Max. 150 PSIG air only Min. 0 PSIG
Temperature range:	-40°F to 450°F (-40°C to 232°C)

Bleed Valves

	Port size	Function	Part number
	1/4"	2-way	315139000

Dimensions

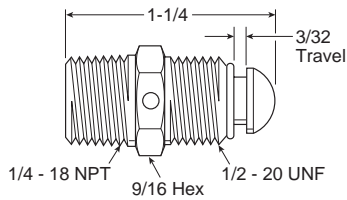

Directair 2 & 4 Series
 Viking Xtreme Lever Series
 4/2 Lever / Pedal Series
 MO Series
 Safety
 Manual / Mechanical Valves
 Brass Poppet / Sliding Seal
 Control Panel Products
 Sensing



For inventory, lead times, and kit lookup, visit www.pdnplu.com

Control Panel Products

HUMAN-MACHINE DIALOG requires devices such as push buttons and selector switches to provide command inputs. A wide variety of these devices are available to meet most application needs; in both pneumatic and electrical switch bodies. All of these devices use the 22 mm (7/8") mounting standard.

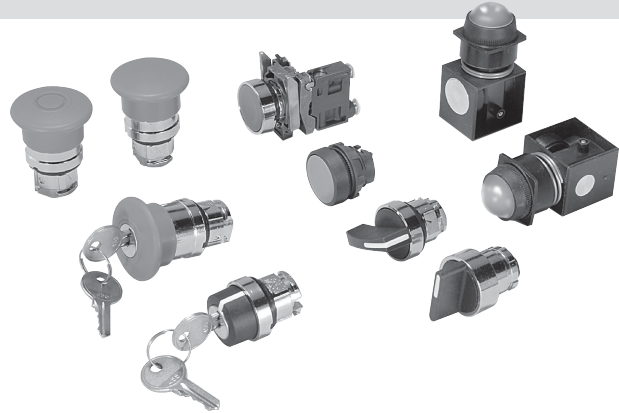

Complete Assemblies— 3/2 Valve Bodies with 5/32" Instant Straight Connections

Flush Push Buttons

	Color	Function	Type of switching*	Part number
	Black			PXBB3111BA2
	Green	Spring return	NNP	PXBB3111BA3
	Red			PXBB3111BA4
	Black	Spring return	NNP+NP	PXBB3251BA2
	Black			PXBB4131BA2
	Green	Spring return	Single universal 3-way	PXBB4131BA3
	Red			PXBB4131BA4
	Black	Spring return	Dual universal 3-way	PXBB4231BA2

* Type of switching: Universal 3-way: valve can be connected either as NP or NNP as required by connecting the primary air supply to port 1 or port 3.

Note: Mount up to three valves on mounting ring.

Mushroom Head Push Buttons (40mm Diameter)

	Color	Function	Type of switching*	Part number
	Black	Spring return	NNP	PXBB3111BC2
	Red	Push-pull		PXBB3111BT4
	Red	Push-pull	NP	PXBB3121BT4
	Black	Spring return	Single universal 3-way	PXBB4131BC2
	Red	Push-pull		PXBB4131BT4

* Type of switching: Universal 3-way: valve can be connected either as NP or NNP as required by connecting the primary air supply to port 1 or port 3.

Note: Mount up to three valves on mounting ring.

Selector Switches

	Color	Function	Type of switching*	Part number
	Black	2 maintained positions with std. handle	NNP	PXBB3111BD2
	Black		NNP+NP	PXBB3211BD2
	Black		NNP+NP	PXBB3251BD2
	Black	3 maintained positions with std. handle	NNP+NP	PXBB3211BD3
	Black		NNP+NP	PXBB3251BD3
	Black	3 positions, spring return to center with long handle	NNP+NP	PXBB3211BJ5
	Black	2 maintained positions with std. Handle	Single universal 3-way	PXBB4131BD2
	Black	2 maintained positions with std. handle	Dual universal 3-way	PXBB4231BD2
	Black	3 maintained positions with std. handle	Dual universal 3-way	PXBB4231BD3
	Black	3 maintained positions with long handle	Dual universal 3-way	PXBB4231BJ5

* Type of switching: Universal 3-way: valve can be connected either as NP or NNP as required by connecting the primary air supply to port 1 or port 3.

Most popular.



For inventory, lead time, and kit lookup, visit www.pdnplu.com

Directair 2
& 4 Series

Viking Xtreme
Lever Series

42 Lever/
Pedal Series

M0 Series

Safety



Manual / Mechanical
Valves

Brass Poppet /
Sliding Seal

Control Panel
Products





Sensing

Accessories

Control Panel Products



For Use With PXBB Valve Bodies and ZBE Electrical Switch Bodies

Push Buttons

	Color	Function	Type	Plastic head**	Metal head*
				Part number	
	Black	Spring return	Flush	ZB5AA2	ZB4BA2
	Green			ZB5AA3	ZB4BA3
	Red			ZB5AA4	ZB4BA4
	Yellow			—	ZB4BA5
	Blue			—	ZB4BA6
Black	ZB5AL2			ZB4BL2	
	Green	Spring return	Extended	ZB5AL3	ZB4BL3
	Red			ZB5AL4	ZB4BL4
	Yellow			—	ZB4BL5
	Black	Spring return	Booted	—	ZB4BPA2
	Green			—	ZB4BPA3
	Red			—	ZB4BPA4
	Black	Detent 2 position	Flush	—	ZB4BH02
	Green			—	ZB4BH03
	Red			—	ZB4BH04

* ZB4*** model numbers are metal head operators
 ** ZB5*** model numbers are plastic head operators, use with plastic mounting ring.



Mushroom Head Push Buttons

	Color	Function	Description	Part number*
	Black	Spring return	Ø 40mm head	ZB4BC2
	Green			ZB4BC3
	Red			ZB4BC4
	Black	Latching push-pull	Ø 40mm head	ZB4BT2
Red	ZB4BT84			
	Black	Spring return	Ø 60mm head	ZB4BR2
	Green			ZB4BR3
	Red			ZB4BR4

* ZB4*** model numbers are metal head operators



For Push Buttons and Visual Indicators

Mounting Ring for Valve Bodies, Switch Bodies and Operating Heads

Description	Part number
 Metal mounting ring	ZB4BZ009
 Plastic mounting ring	ZB5AZ009

Note: To release push button from mounting ring, pull lever on top of mounting ring up and remove push button operator. To assemble push button operator to mounting ring, align arrows and snap into place.

Selector Switches

Standard black handle			
Description	Function	Part number*	
Maintained	2 positions	ZB4BD2	
Spring return from right to left		ZB4BD4	
Maintained	3 positions	ZB4BD3	
Spring return to center from left and right		ZB4BD5	
Maintained right spring return from left to center	3 positions	ZB4BD7	
Maintained left spring return from right to center	3 positions	ZB4BD8	
Long Black Handle			
Maintained	2 positions	ZB4BJ2	
Spring return from right to left		ZB4BJ4	
Maintained	3 positions	ZB4BJ3	
Spring return to center from left and right		ZB4BJ5	

* ZB4*** model numbers are metal head operators

Key Operated Selectors

Key withdrawal	Function	Part number*
Left	2 maintained positions	ZB4BG2
Left and right		ZB4BG4
Center	3 maintained positions	ZB4BG3
Left and right		ZB4BG5
Center	3 positions 2 spring return to center	ZB4BG7

* ZB4*** Model numbers are metal head operators

Mushroom Head Push Buttons with Key Select

Color	Function	Description	Part number*
Red	Latching turn to release	Ø 40mm head	ZB4BS844
Red	Key latching		ZB4BS944

* ZB4**** model numbers are metal head operators

 Most popular.



For inventory, lead times, and kit lookup, visit www.pdnplu.com

Directair 2 & 4 Series

Viking Xtreme Lever Series

42 Lever / Pedal Series

M0 Series

Safety



Manual / Mechanical Valves

Brass Poppet / Sliding Seal

Control Panel Products

Sensing

For Use With 2B4* Metal Operating Heads**

3/2 Valve Bodies with Mounting Ring

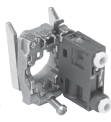

PXBB3111B

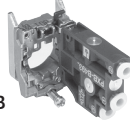

PXBB4131B

Connections	Function	Type of switching*	Part number
5/32" Instant	3/2	NNP	PXBB3111B
5/32" Instant	3/2	NP	PXBB3121B
5/32" Instant	3/2	Universal 3-way	PXBB4131B

* NNP: Normally non-passing.

Note: Mount up to 3 valves on mounting ring for push buttons.
 Mount up to 2 valves on mounting ring for selector switches, valves cannot be mounted in center position.

Specifications

Air Quality – Standard Shop Air, Lubricated or Dry	40 µm Filtration
Flow –	PXBB3• Cv=.08 PXBB4• Cv=.18
Materials –	Body Polyamide Operating Head Zinc Alloy & Plastic
Operating Positions	All Positions
Operating Pressure –	PXBB3• 15 to 115 PSIG (1 to 9 bar) PXBB4• 15 to 145 PSIG (1 to 10 bar)
Ports	5/32" Instant for Semi-Rigid Nylon or Polyurethane Tube
Operating Temperature –	5°F to 140°F (-15°C to 60°C)

Additional Valve Bodies



PXBB3911



PXBB4932



PXBB4931

Connections	Function	Type of switching*	Part number
5/32" instant straight	3/2	NNP	PXBB3911
5/32" instant swivel			PXBB3912
5/32" instant straight	3/2	NP	PXBB3921
5/32" instant swivel			PXBB3922
5/32" instant straight	3/2	Universal	PXBB4931
5/32" instant swivel			PXBB4932

* NNP: Normally non-passing.

Most popular.



For inventory, lead time, and kit lookup, visit www.pdnplu.com

Directair 2
& 4 Series

Viking Xtreme
Lever Series

42 Lever/
Pedal Series

MO Series

Safety



Manual / Mechanical
Valves

Brass Poppet /
Sliding Seal

Control Panel
Products

Sensing

Accessories

Control Panel Products

For Push Buttons and Visual Indicators

Legend Plates for PXBB Devices (22mm)

Description	Part number
Without text for customer engraving	
Black / red background (white letters)	ZBY2101
Yellow / white background (black letters)	ZBY4101
With text for push buttons	
Start	ZBY2303
Stop	ZBY2304
Forward	ZBY2305
Reverse	ZBY2306
Up	ZBY2307
Down	ZBY2308
Right	ZBY2309
Left	ZBY2310
On	ZBY2311
Off	ZBY2312
Open	ZBY2313
Close	ZBY2314
Inch	ZBY2321
Reset	ZBY2323
Power On	ZBY2326
Slow	ZBY2327
Fast	ZBY2328
Emergency stop	ZBY2330
Run	ZBY2334
With text for 2-position selectors	
Off On	ZBY2367
With text for 3-position selectors	
Hand Off Auto	ZBY2387



Most popular.

Blank Legend Plates for Inscription

For PXBB devices (2 lines of 11 characters maximum)

Please indicate the required text when ordering.
(Allow 3 weeks for delivery)

Description	Part number
Black background / White letters	ZBY2002

For 22mm Visual Indicators Only

2 lines of 11 characters maximum

Please indicate the required text when ordering.
(Allow 3 weeks for delivery)

Description	Part number
Black background / white letters	ZB2BY2002

Electrical Switch Bodies

When combined with pneumatic valves, these contact blocks allow different forms of power to be provided from a single push button. Can be mounted with both types of valves PXBB3 / PXBB4.

Type of contact	Part number
Normally open (NO)	ZBE101
Normally closed (NC)	ZBE102



Note: Plastic mounting ring ZB5AZ009 to be used with ZB5 plastic operating heads. Metal mounting ring ZB4BZ009 to be used with ZB4 metal operating heads.

Electrical specification: 240V, 10 Amp

Most popular.



For inventory, lead times, and kit lookup, visit www.pdnplu.com

Directair 2 & 4 Series
Viking Xtreme Lever Series
42 Lever / Pedal Series
MO Series
Safety
Manual / Mechanical Valves
Brass Poppet / Sliding Seal
Control Panel Products
Sensing

Pneumatic Visual Indicators

An indicator ball is rotated by a pneumatic input, changing the visible color. The ball sits behind a clear plastic window, providing a wide field of view. The visual indicators are available in five brightly colored Day-Glow paints for increased visibility. Like push buttons and selector switches, visual indicators use the 22mm (7/8") mounting standard.

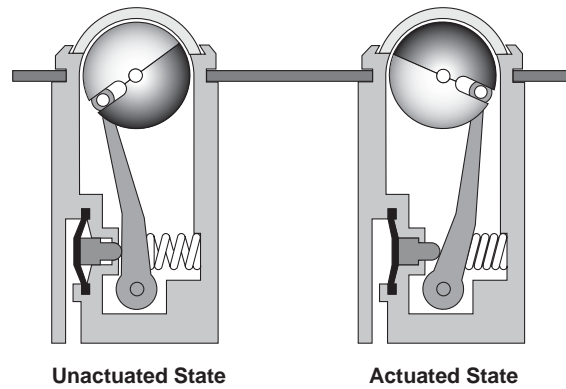

With 5/32" Instant Connections

22mm Visual Indicators

Black Plastic Bezel	Color	Part number "ON" indicator	Part number "OFF" indicator
	Green	PXVF131	PXVF1213
	Red	PXVF141	PXVF1214
	Yellow	PXVF151	PXVF1215
	Blue	PXVF161	PXVF1216
	White	PXVF111	PXVF1211

Notes: The Pneumatic Indicators are black in one position and colored in the other. The colored position corresponds either to the presence of a pressure ("ON" Indicator) or the absence of pressure ("OFF" Indicator).

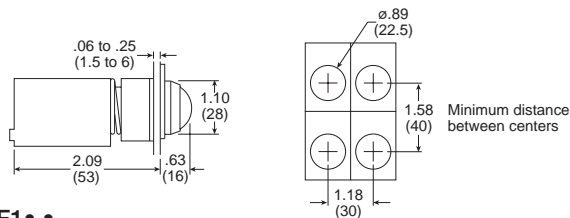

PXVF1 • •

Mounting Accessories

Color	Description	Part number
—	Plastic head (ZB5) mounting nut tightening tool	ZB5AZ905
Black plastic	Guard for 40mm	ZBZ1602

Specifications

Air Quality –	Standard Shop Air, Lubricated or Dry 40 µm Filtration	
Materials –	Body	Polyamide
	Operating Head	Zinc Alloy & Plastic
Number of Operations with Dry Air at 90 PSI (6 bar) and 68°F (20°C) - Frequency 1 Hz	Mushroom Head	300,000 Operations
	Mushroom Head	1 million Operations
Operating Positions	All Positions	
Operating Pressure –	15 to 115 PSIG (1 to 8 bar)	
Ports	5/32" Instant for Semi-Rigid Nylon or Polyurethane Tube 10-32 UNF Available	
Operating Temperature –	Operating	32°F to 122°F (0°C to 50°C)
	Storage	-22°F to 140°F (-30°C to 60°C)

Most popular.



For inventory, lead time, and kit lookup, visit www.pdnplu.com



Directair 2 & 4 Series
Viking Xtreme Lever Series
42 Lever / Pedal Series
MO Series
Safety

Manual / Mechanical Valves
Brass Poppet / Sliding Seal
Control Panel Products
Sensing

Modular Pneumatic / Electric Push Buttons

As with electrical contact switches, pneumatic valve modules can be mounted on a number of different operating heads.

- Pneumatic normally non passing (NNP) is equivalent to electrical normally open (N.O.).
- Pneumatic normally passing (NP) is equivalent to electrical normally closed (N.C.).

Note: Electrical switches can be stacked, but the rear connection on pneumatic switches prevents stacking. Therefore, when mixing electrical and pneumatic switch bodies on the same operator, the pneumatic switch must be mounted last.

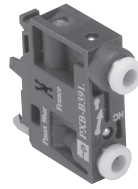

PXBB3911

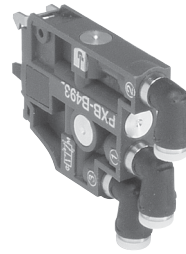

PXBB4932

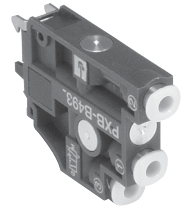

PXBB4931

Push Buttons

Spring Return or Latching
 Mushroom Headed Push Buttons



Standard
 Push Button

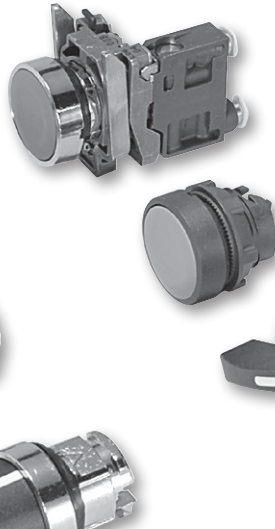

Visual indicators



Selector Switches

2 or 3 Positions,
 Fixed or
 ReturnTo Center

Functionality Explanation

Fluid Power			Universal Description	Electrical	
Function	Symbol			Function	Symbol
Normally Closed (N.C.)	2-Way		Normally Non-Passing (NNP)	Normally Open (N.O.)	
	3-Way				
Normally Open (N.O.)	2-Way		Normally Passing (NP)	Normally Closed (N.C.)	
	3-Way				

Type of Switching: Universal 3-Way: Valve can be connected either as NP or NNP as required by connecting the primary air supply to port 1 or port 3.



- NNP: Normally Non-Passing.
- NP: Normally Passing.
- NNP + NNP: Double Switch Body, Both Normally Non-Passing.
- NNP + NP: Normally Non passing and Normally-Passing.
- NP + NP: Both Normally Passing.

Combination of Output Devices On a Single Mounting Block

Up to 3 output devices (valves or electrical contacts) can be mounted side by side on 1 mounting block.

Note: The central position can only be activated by push button heads.

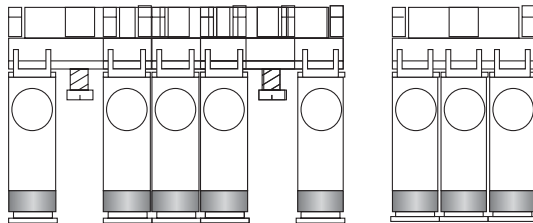

Electrical Contacts and Valves can be Combined Either Side by Side, or by Mounting the Valve on the Back of the Electrical Contact.

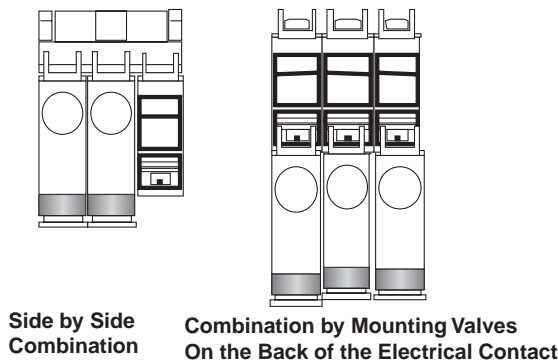

Assembling Output Devices and Heads On ZB5 Series Mounting Block

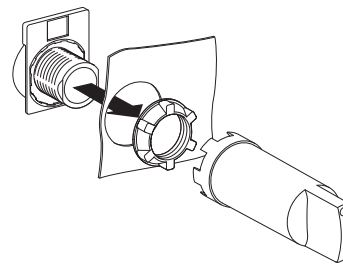

Replacement Old Style Mounting

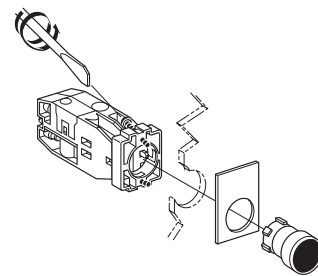

For inventory, lead time, and kit lookup, visit www.pdnplu.com

Directair 2 & 4 Series
Viking Xtreme Lever Series
42 Lever / Pedal Series
MO Series
Safety
Manual / Mechanical Valves
Brass Poppet / Sliding Seal
Control Panel Products
Sensing

Dimensional Data

PXB-B3 Dimensions

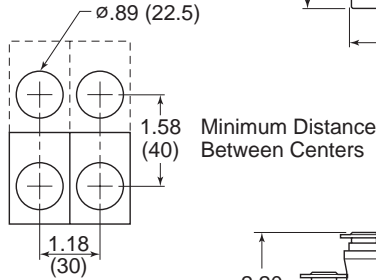
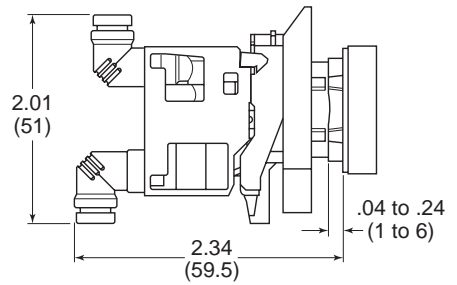
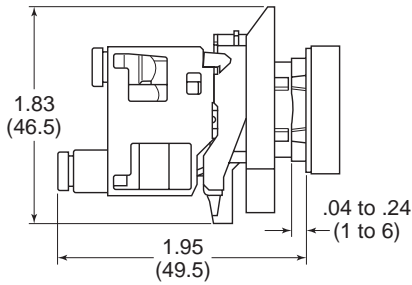

PXB-B4 Dimensions

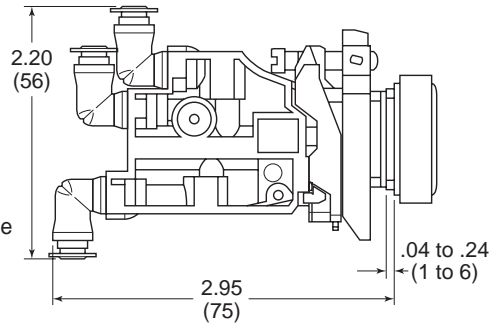
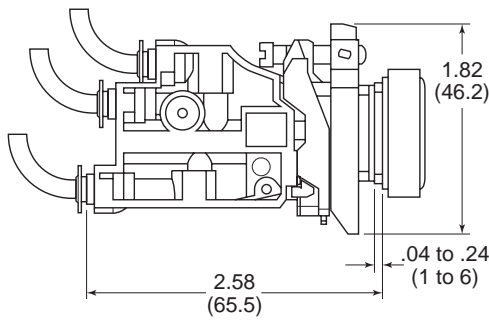

Tube Bending Radius For PXBB3 and PXBB4

- 4 mm O.D. x 2 mm I.D. Tube = Minimum 0.39 (10) Radius
- 4 mm O.D. x 2.7 mm I.D. Tube = Minimum 0.59 (15) Radius

Assembly

Assembling PXB Valves On Mounting Block

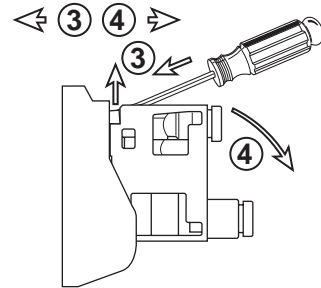
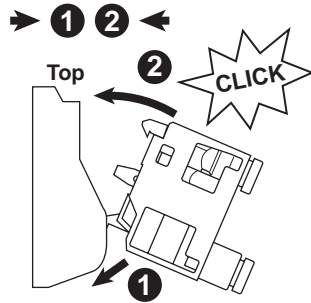

Assembling PXB Valves On the Back of the Electrical Contact

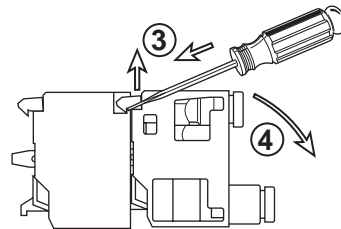
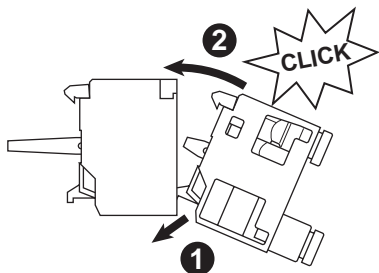

For inventory, lead times, and kit lookup, visit www.pdnplu.com

Directair 2 & 4 Series	Viking Xtreme Lever Series	42 Lever / Pedal Series	MO Series	Safety	Manual / Mechanical Valves
			Brass Poppet / Sliding Seal	Control Panel Products	Sensing

Features

Limit Switches

To achieve the sensing or feedback function, pneumatic sensors can be:

- Limit switches in a variety of sizes and configurations
- Pressure switches with many adjustable ranges
- Components designed specifically for pneumatic technology using pressure variation, air bleed or blocking for detection.

A wide variety of pneumatic sensors are available to suit any application requirement.

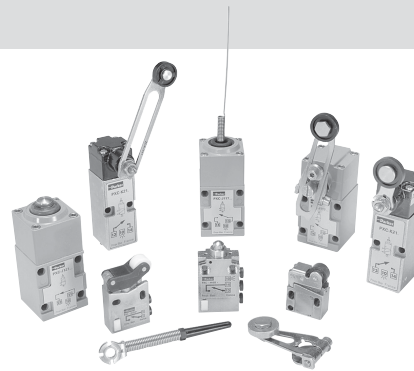

Material specifications

Body	Zinc alloy
Poppets	Polyurethane
Seals	Nitrile (Buna N)

Operating information

Operating pressure:	40 to 115 PSIG (3 to 8 bar)
Operating temperature:	
Operating	32°F to 122°F (0°C to 50°C)
Storage	-22°F to 140°F (-30°C to 60°C)

3/2 Miniature Direct Acting Limit Switches
1/16" I.D. Internal Orifice

	Actuator	Type of switching*	Flow SCFM (NI/min)	Nominal bore	Connection	Part number
	Steel plunger operating levers available	NNP	2.2 (60)	1/16" (1.5mm)	5/32" instant	PXCM111
					10-32 UNF	PXCM115
	Plastic roller	NNP	3.0 (85)		5/32" instant	PXCM121
					10-32 UNF	PXCM125

7/64" I.D. Internal Orifice

	Plastic roller	NNP	8.8 (250)	7/16" (2.5mm)	5/32" instant	PXCM521
--	----------------	-----	-----------	---------------	---------------	----------------

Actuators For Steel Plunger (Use with PXCM11*)

	Plastic roller lever					PXCZ11
--	----------------------	--	--	--	--	---------------

* NNP: Normally non-passing.

Specifications

Air Quality – Standard Shop Air, Lubricated or Dry	40 µm Filtration
Maximum Operating Frequency	5 Hz
Number of Operations with Dry Air at 90 PSI (6 bar) and 68°F (20°C) - Frequency 1 Hz	10 million
Operating Positions	All Positions

Most popular.



For inventory, lead time, and kit lookup, visit www.pdnplu.com



E77

Parker Hannifin Corporation
Pneumatic Division
Richland, Michigan
www.parker.com/pneumatics

Directair 2 & 4 Series
Viking Xtreme Lever Series
42 Lever / Pedal Series
MO Series
Safety





Manual / Mechanical Valves
Brass Poppet / Sliding Seal
Control Panel Products
Sensing

3/2 Compact Pilot Operated Limit Switches
7/64" I.D. Internal Orifice, 5/32" Instant Connections, Pipeable Exhaust Port

	Actuator	Type of switching*	Flow SCFM (NI/min)	Nominal bore	Connection	Part number	
Directair 2 & 4 Series Viking Xtreme Lever Series 42 Lever / Pedal Series		Steel plunger operating levers available				PXCM601A110	
		Steel roller plunger	NNP	8.8 (250)	7/64" (2.5mm)	5/32" instant	PXCM601A102
		90° Steel roller plunger					PXCM601A103

Standard Duty Limit Switches – “K” Series

Plunger Operated Limit Switches
1/8" I.D. Internal Orifice, 5/32" Instant Connections, Pipeable Exhaust Port

	Actuator	Type of switching*	Flow SCFM (NI/min)	Nominal bore	Connection	Part number		
MO Series Safety		Steel plunger	NNP			PXCK21101		
			NP			PXCK22101		
		Steel roller plunger	NNP			PXCK21102		
			NP			PXCK22102		
		Plastic roller plunger	NNP	7.4 (210)	1/8" (3mm)	5/32" instant	PXCK21121	
			NP				PXCK22121	
			Cats whisker	NNP				PXCK21106
				NP				PXCK22106

* NNP: Normally non-passing. 

 Most popular.





For inventory, lead times, and kit lookup, visit www.pdnplu.com

E78

Parker Hannifin Corporation
 Pneumatic Division
 Richland, Michigan
www.parker.com/pneumatics

Roller Operated Limit Switches

1/8" I.D. Internal Orifice, 5/32" Instant Connections, Pipeable Exhaust Port

	Actuator	Type of switching*	Flow SCFM (NI/min)	Nominal bore	Connection	Part number
	Fixed delrin roller lever multi-function head actuates: - from right and left - from right - from left	NNP	7.4 (210)	1/8" (3mm)	5/32" instant	PXCK2110031
		NP				PXCK2210031
	Adjustable delrin roller lever multi-function head actuates: - from right and left - from right - from left	NNP				PXCK2110041
		NP				PXCK2210041

Separate Pneumatic Switch Bodies

	Actuator	Type of switching*	Part number
	For use with ZCK series operating heads	NNP	PXCK211
		NP	PXCK221

Pneumatic Switch Bodies with Rotary Heads

	Actuator	Type of switching*	Part number
	Multi-function head actuates: - from right and left - from right - from left	NNP	PXCK21100
		NP	PXCK22100

Field Conversion of Rotary Operating Head

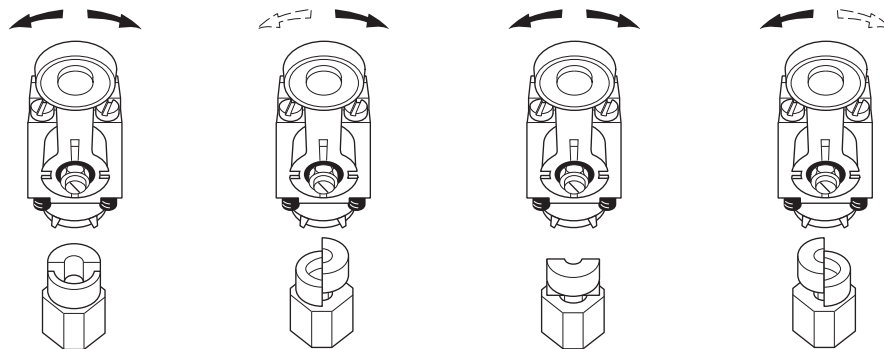

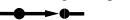
* NNP: Normally non-passing. 
 NP: Normally passing. 

 Most popular.



For inventory, lead time, and kit lookup, visit www.pdnplu.com

Directair 2
& 4 Series

Viking Xtreme
Lever Series

42 Lever/
Pedal Series

MO Series

Safety



Manual / Mechanical
Valves

Brass Poppet /
Sliding Seal

Control Panel
Products

Sensing

Part Numbers

Standard Duty Limit Switches – “K” Series









Operating Heads

For Use With PXCK Switch Bodies

Actuator	Description	Part number
Rotary operated		
	Die cast zinc	ZCKG00
Plunger operated		
Roller plunger		ZCKD02
Whisker		ZCKD06
Rod plunger	Plunger operated	ZCKD10
Delrin roller lever on plunger		ZCKD21
Steel roller lever on plunger		ZCKD23

Operating Levers for Rotary Heads

For Use With Rotary Head ZCKG00

Actuator	Description	Part number
	Steel 1/8" square	ZCKY51
	Fiberglass 1/8" dia. round	ZCKY52
	Plastic spring rod lever	ZCKY81
	Metal spring rod lever	ZCKY91
	Delrin roller lever	ZCKY11
	Steel roller lever	ZCKY13
	Adjust. delrin roller lever	ZCKY41
	Adjust. steel roller lever	ZCKY43

Heavy Duty Limit Switches – “J” Series

Switch Bodies Only











Type of switching*	Part number
NNP	PXCJ117
NP	PXCJ127

Separate Pneumatic Switch Bodies

Direction of actuator	Type of switching*	Part number
Right & left, spring return	NNP	PXCJ11701
Right or left, spring return		PXCJ11705
Right & left, spring return	NP	PXCJ12701
Right or left, spring return		PXCJ12705









Operating Levers for Rotary Heads



Die Cast Zinc. For Use With PXCJ Switch Bodies

Operator	Description	Part number
	Delrin roller	ZC2JY11
	Steel roller	ZC2JY13
	Offset delrin roller	ZC2JY21
	Plastic spring rod	ZC2JY81
	Metal spring rod	ZC2JY91
	Delrin roller	ZC2JY31
	Offset delrin roller	ZC2JY41
	Single track, delrin roller	ZC2JY71
	Fork lever	ZC2JY61
	Double track, delrin rollers	ZC2JY61

Top Plunger & Rotary Operating Heads

Die Cast Zinc. For Use With PXCJ Switch Bodies

Operation	Description	Part number
Top Plunger Type		
	Top push	ZC2JE61
	Top roller push	ZC2JE62
	Side push	ZC2JE63
	Cat's whisker	ZC2JE70
Rotary Type		
	From left & right	ZC2JE01
	Counterclockwise from right	ZC2JE02
	Clockwise from left	ZC2JE03
	From left or right	ZC2JE05
	Maintained positions	ZC2JE09

* NNP: Normally non-passing. 
 NP: Normally passing. 

 Most popular.



For inventory, lead times, and kit lookup, visit www.pdnplu.com

Directair 2 & 4 Series

Viking Xtreme Lever Series

42 Lever / Pedal Series

MO Series

Safety



Manual / Mechanical Valves

Brass Poppet / Sliding Seal

Control Panel Products

Sensing

Operator Specifications

	PXCK2••01	PXCK2••02	PXCK2••03	PXCK2••06	PXCK2••00 + Actuator
Differential angle	—	—	—	12°	3°
Differential travel	.008" (0.2 mm)	.008" (0.2 mm)	.008" (0.2 mm)	—	—
Maximum angle of travel	—	—	—	—	80°
Maximum travel (B) at 90 PSIG (6 bar)	.228" (5.8 mm)	.228" (5.8 mm)	.228" (5.8 mm)	—	—
Minimum pre-travel (A) at 90 PSIG (6 bar)	.087" (2.2 mm)	.087" (2.2 mm)	.102" (2.6 mm)	—	—
Minimum operating force at 90 PSI (6 bar)	3.6 lbf (16N)	4.5 lbf (20N)	3.4 lbf (15N)	—	—
Minimum operating torque at 90 PSI (6 bar)	—	—	—	17.0 oz in (120mNm)	29.8 oz in (210mNm)
Operating angle	—	—	—	35°	31° (Minimum lever travel including pre-travel required for operation)

Operating Diagram

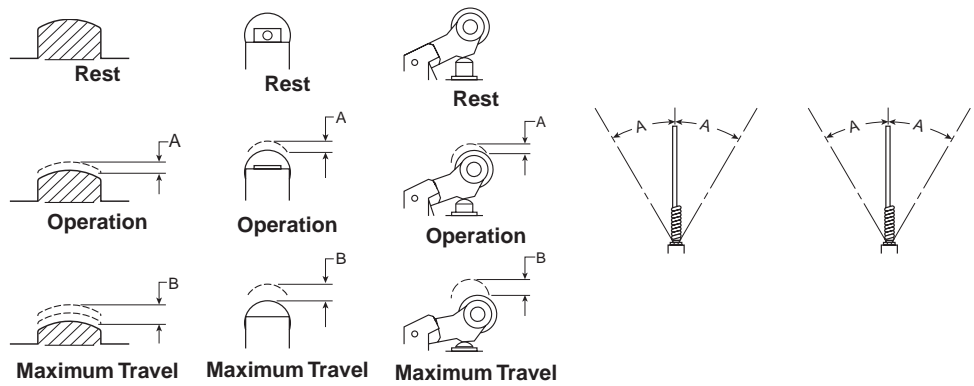

Operators

	PXCM111	PXCM121	PXCM521
Differential Travel at 90 PSI (6 bar)	.006" (0.15 mm)	.012" (0.3 mm)	.020" (0.5 mm)
Maximum Travel (B) at 90 PSIG (6 bar)	.055" (1.4 mm)	.126" (3.2 mm)	.228" (5.8 mm)
Minimum Pre-Travel (A) at 90 PSIG (6 bar)	.035" (0.9 mm)	.079" (2 mm)	.087" (2.2 mm)
Minimum Operating Force at 90 PSI (6 bar)	2.5 lb (11 N)	1.0 lb (4.5 N)	1.6 lb (7 N)

Operating Diagram

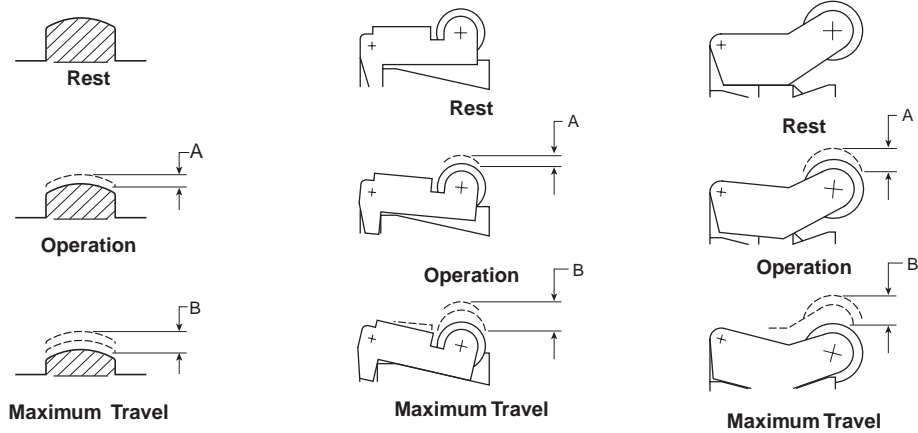

	PXCM601A110	PXCM601A102	PXCM601A103	PXCM601A110 + XCMZ24
Differential Travel at 90 PSI (6 bar)	.012" (0.3 mm)	.008" (0.2 mm)	.020" (0.5 mm)	.047" (1.2 mm) (A)
Maximum Travel (B) at 90 PSIG (6 bar)	.197" (5 mm)	.197" (5 mm)	.197" (5 mm)	—
Minimum Pre-Travel (A) at 90 PSIG (6 bar)	.066" (1.7 mm)	.066" (1.7 mm)	.066" (1.7 mm)	.370" (9.4 mm) (A)
Minimum Operating Force at 90 PSI (6 bar)	5.4 lbf (24 N)	5.2 lbf (23 N)	5.2 lbf (23)	4.3 lbf (19)

Operating Diagram

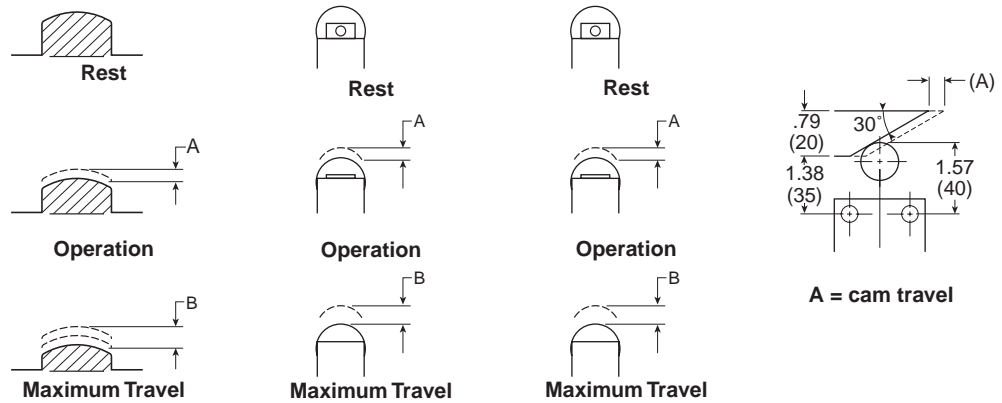

Directair 2 & 4 Series

Viking Xtreme Lever Series

422 Lever / Pedal Series

MO Series

Safety



Manual / Mechanical Valves

Brass Poppet / Sliding Seal

Control Panel Products

Sensing



For inventory, lead times, and kit lookup, visit www.pdnplu.com

Miniature Limit Switches

PXCM111

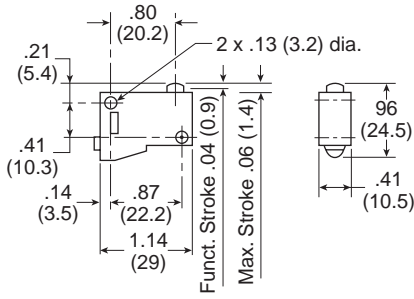

PXCZ12

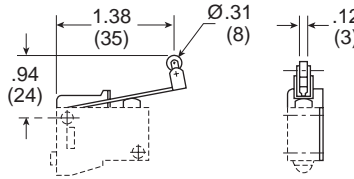

PXCZ11

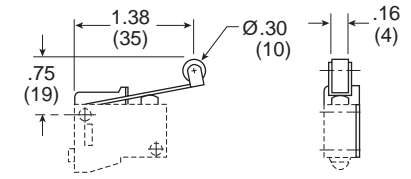

PXCM121, PXCM131

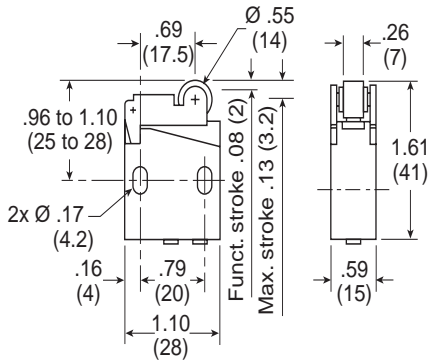

PXCM521

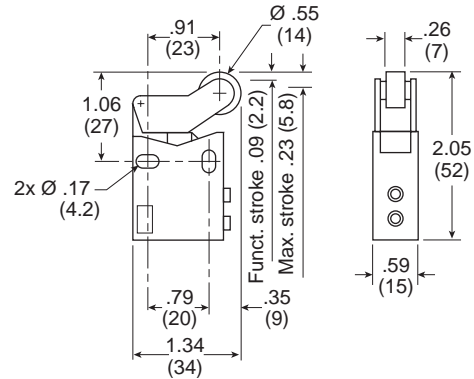

Compact Limit Switches

PXCM601A102

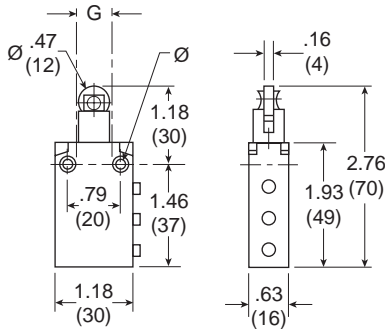

PXCM601A103

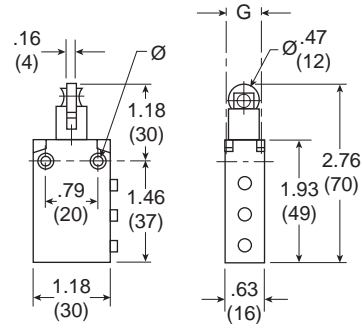

Ø:
 2 mounting holes Ø .17" (4.3)
 2 countersunk Ø .32" (8.2)
 depth 4 mm

PXCM601A110

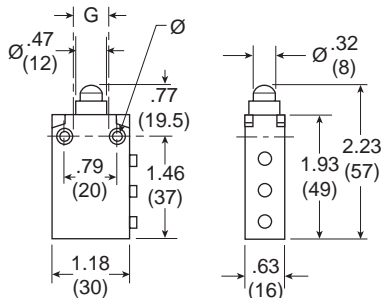

G:
 top mounting holes, 2 x M5
 .71" (18 mm) centers



For inventory, lead time, and kit lookup, visit www.pdnplu.com

Directair 2
 & 4 Series

Viking Xtreme
 Lever Series

42 Lever/
 Pedal Series

MO Series

Safety



Manual / Mechanical
 Valves

Brass Poppet /
 Sliding Seal

Control Panel
 Products

Sensing

Dimensional Data

K Series

PXCK21101, PXCK22101

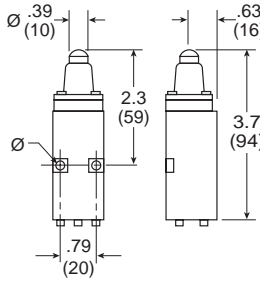

PXCK21102, PXCK22102

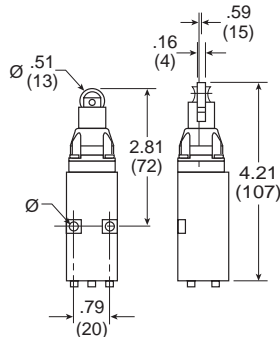

PXCK21121, PXCK22121

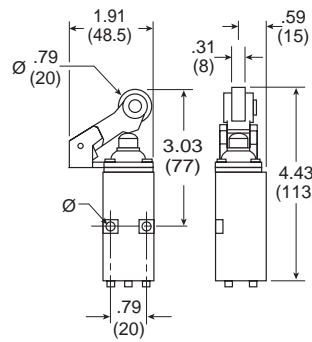

PXCK21106, PXCK22106

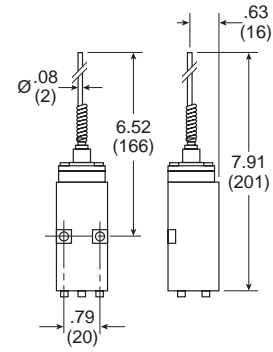

PXCK2110031, PXCK2210031

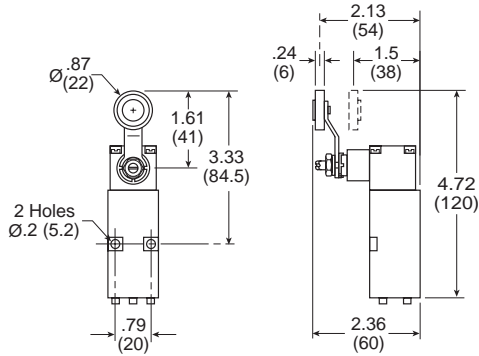

PXCK2110041, PXCK2210041

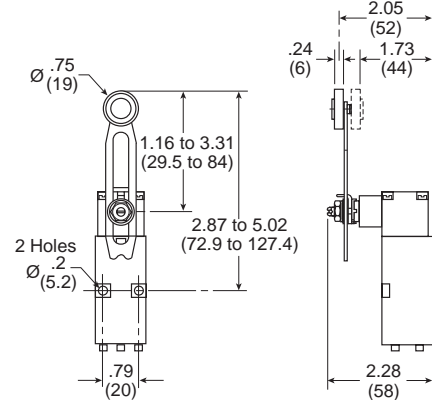

Pneumatic Switch Bodies

PXCK211, PXCK221

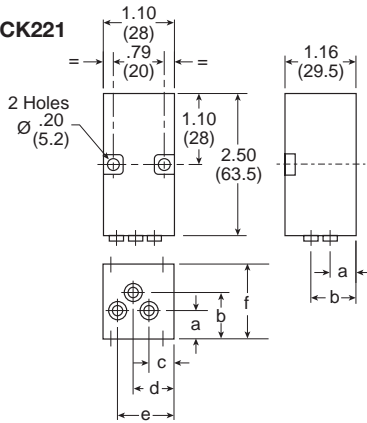

	inch	mm
a	.39	10
b	.77	19.5
c	.35	9
d	.61	15.5
e	.87	22
r	1.66	29.5

Rotary Heads with Operating Levers

ZCKY81

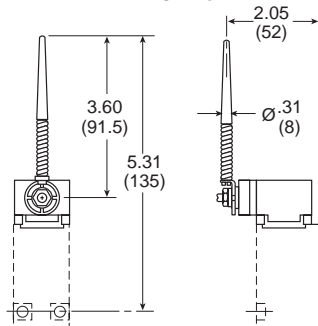

ZCKY91

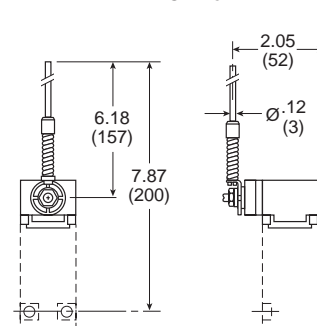

For inventory, lead times, and kit lookup, visit www.pdnplu.com

Directair 2 & 4 Series
Viking Xtreme Lever Series
42 Lever / Pedal Series
MO Series
Safety
Manual / Mechanical Valves
Brass Poppet / Sliding Seal
Control Panel Products
Sensing

J Series

Switch Body With Plunger Heads

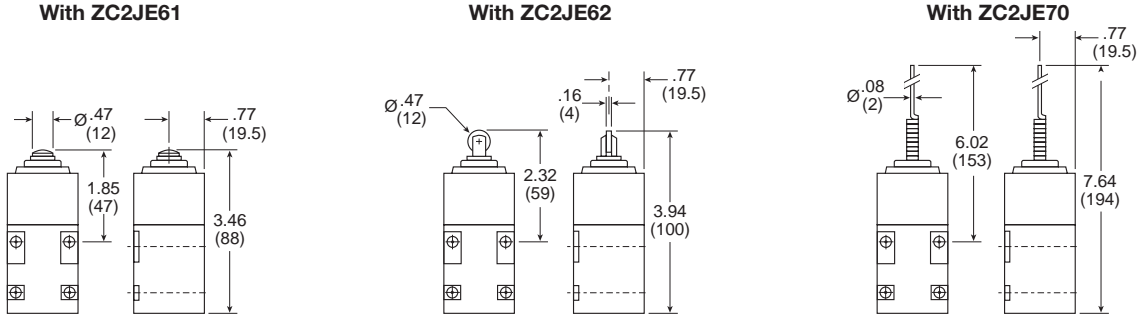

Switch Body With Rotary Heads and Operating Levers

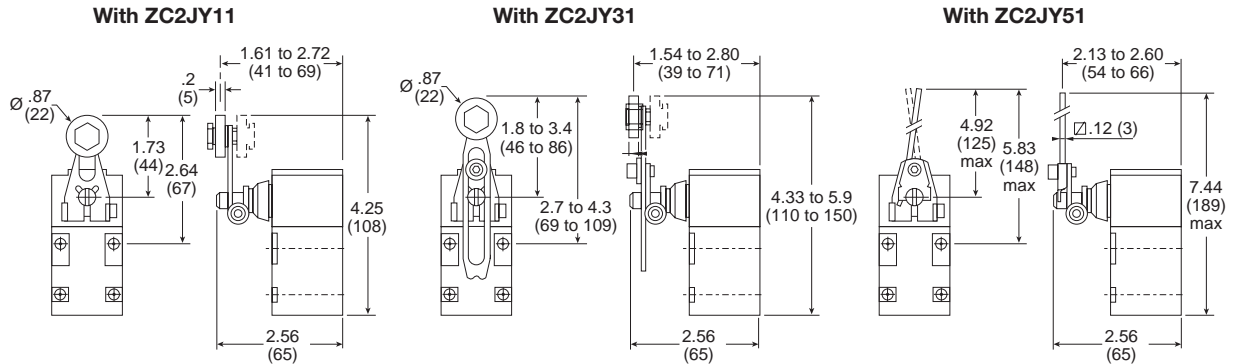

Rotary Heads With Operating Levers

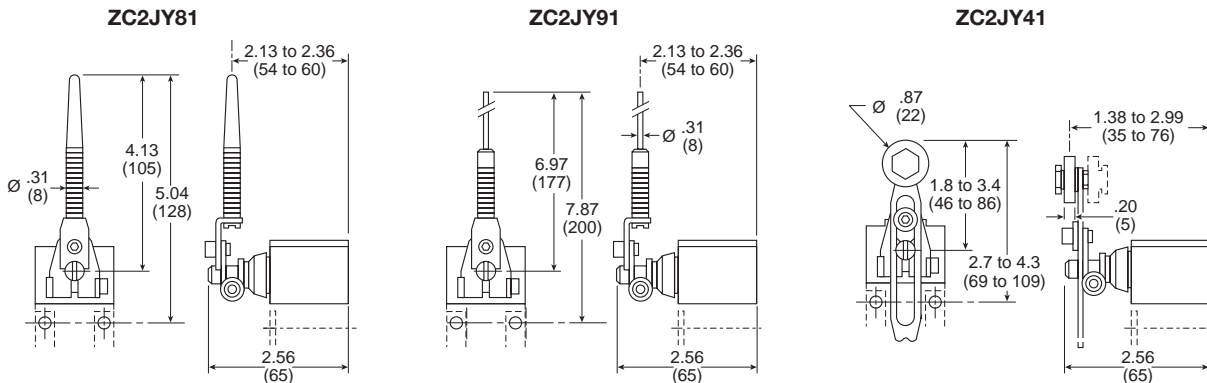

Pneumatic Switch Bodies

PXCJ117, PXCJ127

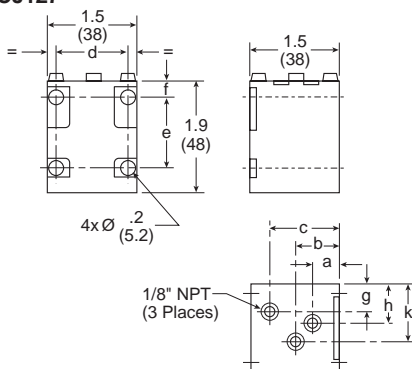

	inch	mm
a	.47	12
b	.75	19
c	1.16	29.5
d	1.14 to 1.18	29 to 30
e	1.18	30
f	.28	7
g	.43	11
h	.51	13
k	.94	24



For inventory, lead time, and kit lookup, visit www.pdnplu.com

E85

Parker Hannifin Corporation
 Pneumatic Division
 Richland, Michigan
www.parker.com/pneumatics

Directair 2
& 4 Series

Viking Xtreme
Lever Series

42 Lever/
Pedal Series

MO Series

Safety



Manual / Mechanical
Valves

Brass Poppet /
Sliding Seal

Control Panel
Products

Sensing

Parker Pneumatic

Directair 2 & 4 Series
Viking Xtreme Lever Series
42 Lever / Pedal Series
MO Series
Safety

Manual / Mechanical Valves
Brass Poppet / Sliding Seal
Control Panel Products
Sensing



For inventory, lead times, and kit lookup, visit www.pdnplu.com

Pneumatic Valve Products
Accessories

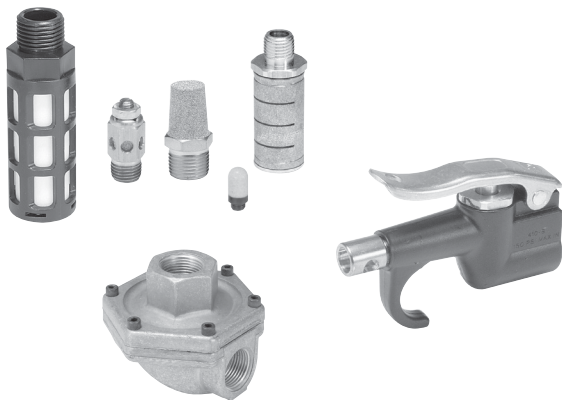
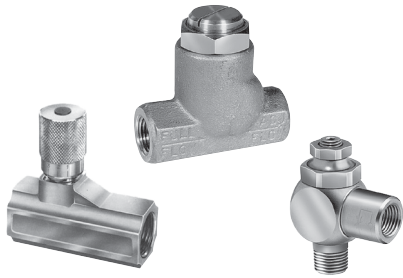

Flow Controls & Check Valves

337 Micrometer Series	F2
338 Series	F3
3250 Series	F4-F5
3251 Series	F6
339 Series	F7
3047 Series	F7

Miscellaneous Accessories

EM Series Sintered Bronze Muffler / Filters	F8
Muffler / Flow Controls	F8
Breather Vents	F9
Silencers	F9
Stainless Steel Mufflers	F10
Air Line Silencers, Plastic	F11-F12
ECS Reclassifier	F13
Quick Exhaust & Shuttle Valves	F14-F16
Blocking Valves	F17-F18, F21
Threshold Sensors, PWS Series	F19-F21
Tank Valves	F22
Blow Guns	F23-F24

Integrated Fittings

Index	F25-F26
Compact Flow Control Valves	F27-F28
Miniature Flow Control Valves	F29
Swivel Outlet Flow Control Valves	F30
Plug-In Flow Control Valves	F31
In-Line Flow Control Valves	F32-F33
Compact Metal Flow Control Valves	F34
Flow Control Check Valves	F35-F36
Blocking Flow Control Valves	F37
Threshold Sensors	F38



337 Series Micrometer Flow Control Valves, 1/8" to 3/4" Ports

The "337" Series Flow Control Valves meter flow of air in one direction and allow free flow in the reverse direction.

Valves are manufactured with a fine tapered needle providing precise flow control, even at low flow rates. The perimeter of the adjustment knob features numerical micrometer position markings providing a visual indication of the setting. Once the desired flow is selected, a set screw can be tightened to maintain the setting.

These valves are available with NPTF ports in 1/8", 1/4", 3/8", 1/2", and 3/4" sizes. This series is recommended for pneumatic service.

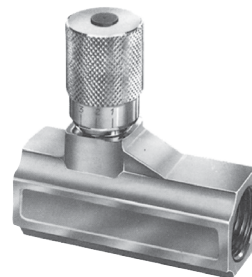

Material Specifications

Body	Brass
Check Seal	Urethane
Knob	Aluminum
Needle	Stainless steel
Needle Seals	Buna N (Fluorocarbon optional – consult factory)
Retainer	Zinc- Plated Steel
Spring	Stainless Steel
Set Screw	Steel

Operating information

Maximum operating pressure: 250 PSIG
Cracking pressure for return check poppet 1 to 2 PSIG

Operating temperature:*

Standard:	0°F to 180°F
Extended:	0°F to 300°F (consult factory)

* Ambient temperatures below freezing require moisture-free air. Ambient temperatures below freezing and above 180° require lubricants especially selected for suitability at these temperatures. Pneumatic valves should be used with filtered and lubricated air.

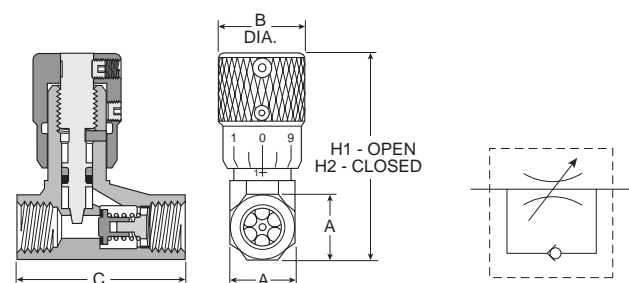

337 Micrometer Flow Control Valves – NPT

Port size	Flow (SCFM †)		A	B	C	H1	H2	Part number	Service kits
	Adj.	Free flow							
1/8"	15	32	9/16"	0.75	1.47	2.03	1.81	003371000	003378000
1/4"	28	75	11/16"	0.75	1.47	2.28	2.03	003371001	003378001
3/8"	59	139	7/8"	0.88	2.31	2.84	2.53	003371002	003378002
1/2"	126	183	1-3/16"	1.06	3.25	3.62	3.22	003371003	003378003
3/4"	140	327	1-3/8"	1.06	3.25	3.72	3.31	003371004	003378004

337 Micrometer Flow Control Valves – BSPP

Port size	Flow (SCFM †)		A	B	C	H1	H2	Part number	Service kits
	Adj.	Free flow							
1/8"	15	32	9/16"	0.75	1.47	2.03	1.81	00337G1000	003378000
1/4"	28	75	11/16"	0.75	1.47	2.28	2.03	00337G1001	003378001

† At 100 PSIG inlet pressure with full pressure drop.

Most popular.



For inventory, lead times, and kit lookup, visit www.pdnplu.com

338 Series Flow Control Valves, 1/8" to 3/4" Ports

"338" Series needle valves bi-directionally meter the flow of air through the valve.

This series features a fine tapered needle providing precise flow of air in both directions. Numerical micrometer position markings are stamped on the perimeter of the adjustment knob which provide a visual indication of the setting. Once the desired flow is selected, a set screw can be tightened to maintain the setting.

These valves are available with NPTF ports in 1/8", 1/4", 3/8" 1/2" and 3/4" sizes. This series is recommended for pneumatic service.



Material Specifications

Body	Brass
Internal Components	Stainless steel
Seals	Buna N (Fluorocarbon optional – consult factory)

Operating information

Maximum operating pressure: 250 PSIG

Operating temperature:*

Standard: 0°F to 180°F

Extended: 0°F to 300°F (consult factory)

* Ambient temperatures below freezing require moisture-free air. Ambient temperatures below freezing and above 180° require lubricants especially selected for suitability at these temperatures. Pneumatic valves should be used with filtered and lubricated air.

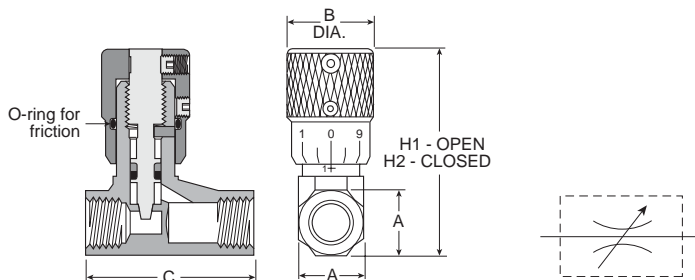

338 Needle Valves – NPT

Port size	Flow (SCFM †)	A	B	C	H1	H2	Part number	Service kits
1/8"	15	9/16"	0.75	1.47	2.03	1.81	003381100	003378000
1/4"	28	11/16"	0.75	1.47	2.28	2.03	003381101	003378001
3/8"	59	7/8"	0.88	2.31	2.84	2.53	003381102	003378002
1/2"	126	1-3/16"	1.06	3.25	3.62	3.22	003381103	003378003
3/4"	140	1-3/8"	1.06	3.25	3.72	3.31	003381104	003378004

338 Needle Valves – BSPP

Port size	Flow (SCFM †)	A	B	C	H1	H2	Part number	Service kits
1/8"	15	9/16"	0.75	1.47	2.03	1.81	00338G1100	003378000
1/4"	28	11/16"	0.75	1.47	2.28	2.03	00338G1101	003378001

† At 100 PSIG inlet pressure with full pressure drop.

Most popular.



For inventory, lead time, and kit lookup, visit www.pdnplu.com

3250 Series Flow Control Valves, 1/8" to 3/4" Ports

The "3250" Series Flow Control Valves are specifically designed to accurately meter the flow of air in one direction and allow free flow in the opposite direction. The "3250" Series Flow Control Valves are also suitable for low pressure hydraulic service.

When air is moving in the free flow direction through the valve, it forces the poppet off its seat and unrestricted air flow is permitted.

When air is moving in the metered direction through the valve, air pressure and the force of the poppet spring causes the poppet to close. Flow must then be through the orifice that is controlled by the metering screw. Opening this screw allows more flow; closing it, less flow.



Operating information

Operating pressure:	400 PSIG (Air) 800 PSIG (Hydraulic)
Operating temperature:	Standard: -40°F to 180°F Extended: -20°F to 400°F

Valve will operate mounted in any position. Lock nut on metering screw prevents change in setting during operation.

Material Specifications

Body	Brass
Internal Components	Brass, Stainless steel
Seals	Buna N

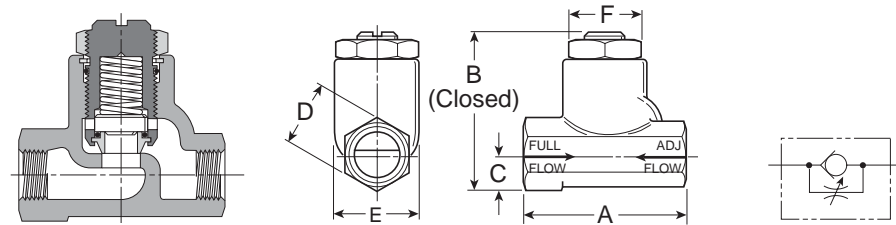

3250 Flow Control Valves, 1/8" to 3/4" Ports – NPT

Port size	Max. flow (SCFM)		A	B	C	D	E	F	Part number
	Metered direction	Free flow direction							
1/8"	70	60	1.75	1.56	0.37	0.62	0.81	0.68	032500119
1/4"	130	120	2.33	1.97	0.44	0.75	1.09	0.94	032500219
3/8"	220	205	2.66	2.44	0.56	1.00	1.38	1.19	032500319
1/2"	295	346	3.11	3.06	0.75	1.25	1.63	1.38	032500419
3/4"	420	615	3.56	3.69	0.88	1.50	2.00	1.75	032500519

3250 Flow Control Valves, 1/8" to 3/4" Ports – BSPP

Port size	Max. flow (SCFM)		A	B	C	D	E	F	Part number
	Metered direction	Free flow direction							
1/8"	70	60	1.75	1.56	0.37	0.62	0.81	0.68	03250G0119
1/4"	130	120	2.33	1.97	0.44	0.75	1.09	0.94	03250G0219
3/8"	220	205	2.66	2.44	0.56	1.00	1.38	1.19	03250G0319
1/2"	295	346	3.11	3.06	0.75	1.25	1.63	1.38	03250G0419
3/4"	420	615	3.56	3.69	0.88	1.50	2.00	1.75	03250G0519

Most popular.



For inventory, lead times, and kit lookup, visit www.pdnplu.com

3250 Series Needle Valves, 1" to 1-1/2" Ports

These extra large flow control valves have been developed to provide effective flow settings for large diameter cylinders and for other similar air applications. Each valve has a fine screw adjustment allowing precise settings which are secured by a sturdy lock nut.

Large internal port passages coupled with unique soft seal poppet and inline design provide maximum full flow capacity and minimum pressure drop in the free flow direction. Their cone shaped brass metering valve will provide consistent cylinder speed by regulating cylinder exhaust.

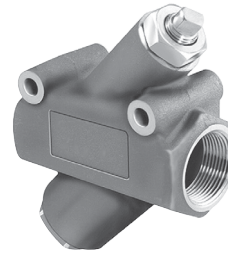

Material Specifications

Body	Cast Aluminum
Internal Components	Brass, Aluminum
Seals	Buna N, Urethane
Spring	Stainless Steel

Operating information

Maximum operating pressure: 250 PSIG
 Operating temperature:
 Standard: -40°F to 180°F
 Extended: -40°F to 350°F (consult factory)

Flow Controls
& Check Valves

Misc
Accessories

Integrated
Fittings

Accessories

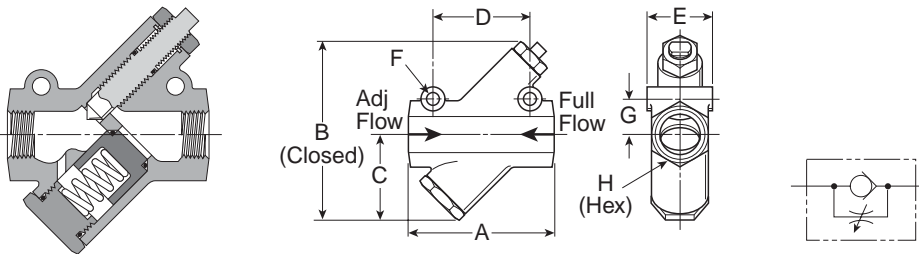

3250 Flow Control Valves, 1" to 1-1/2" Ports – NPT

Port size	Max. flow needle open		A	B	C	D	E	F	G	H	Part number
	SCFM†	Cv									
1"	70	60	5.00	6.50	3.00	3.25	2.25	.39	1.31	2.13	032501000
1-1/4"	130	120	5.00	6.50	3.00	3.25	2.25	.39	1.31	2.13	032501250
1-1/2"	295	346	5.88	8.00	3.75	3.50	2.50	.39	1.50	2.38	032501500

3250 Flow Control Valves, 1" to 1-1/2" Ports – BSPP

Port size	Max. flow needle open		A	B	C	D	E	F	G	H	Part number
	SCFM†	Cv									
1"	70	60	5.00	6.50	3.00	3.25	2.25	.39	1.31	2.13	03250G1000
1-1/4"	130	120	5.00	6.50	3.00	3.25	2.25	.39	1.31	2.13	03250G1250
1-1/2"	295	346	5.88	8.00	3.75	3.50	2.50	.39	1.50	2.38	03250G1500

† At 100 PSIG inlet pressure with full pressure drop.

Most popular.



For inventory, lead time, and kit lookup, visit www.pdnplu.com

3251 Series Right Angle Flow Control Valves, 1/8" to 1/2" Ports

The Right Angle Flow Control is an ideal solution to cylinder speed control where space is at a premium. Costly fittings, connections and piping expenses can be eliminated because the valve can rotate 360°, the piping alignment can be in any direction. It then locks into place. The 1/8" model can be rotated after final assembly.

Install by threading male end directly into cylinder port. The free-flow and metered-flow direction is automatically predetermined. Free-flow direction is into cylinder and metered-flow is out of the cylinder. Flow is adjusted with an Allen wrench and locked with nut.

Right Angle Flow Control also available with Prestolok fittings on inlet port to accommodate 5/32 - 3/8 tube sizes. This allows for quick connection and eliminates need for separate tube fitting.

Material Specifications

Body	Brass
Plunger	Brass and Acetal
Seals	Buna N



Shown with Threaded Inlet



Shown with Prestolok Inlet Fitting

Operating information

Operating pressure:	125 PSIG (863 kPa) max.
Operating temperature:	0°F to 140°F (-18°C to 60°C)

Flow Controls & Check Valves

Misc Accessories

Integrated Fittings

Accessories

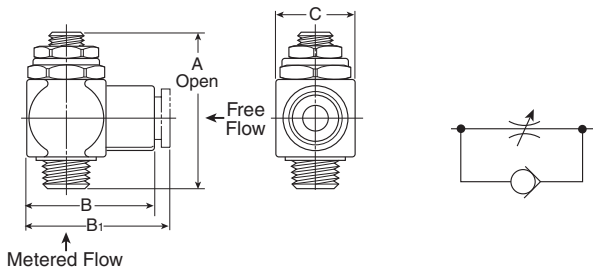

3251 Flow Control Valves – NPT

Thread (NPT) male	Thread (NPT) female	Cv		A mm	B mm	C mm	Weight		Part number
		Adjusted flow	Free flow				oz.	kg.	
1/8	1/8	0.26	0.20	44	30	17	2.0	0.9	032510125
1/4	1/4	0.75	0.68	51	36	23	4.5	2.0	032510250
3/8	3/8	0.84	0.72	58	43	27	7.0	3.2	032510375
1/2	1/2	1.64	1.41	68	53	32	11.0	5.0	032510500

With Prestolok Fittings

1/8	5/32	0.19	0.16	44	30	17	2.0	0.9	032511215
1/8	1/4	0.28	0.22	44	30	17	2.0	0.9	032511225
1/4	1/4	0.51	0.44	51	36	23	4.5	2.0	032512525
1/4	3/8	0.62	0.53	51	36	23	4.5	2.0	032512538
3/8	3/8	0.78	0.65	58	43	27	7.0	3.2	032513838

CAUTION: If it is possible that the ambient temperature may fall below freezing, the medium must be moisture-free to prevent internal damage or unpredictable behavior.

Most popular.



For inventory, lead times, and kit lookup, visit www.pdnplu.com

339 Series Check Valves, 1/8" to 3/4" Ports

"339" Series check valves allow free flow in one direction and provide positive checked flow in the reverse direction. These valves are available with NPTF ports in 1/8", 1/4", 3/8", 1/2" & 3/4" sizes. This series is recommended for pneumatic service.



Material Specifications

Body	Brass
Internal Components	Brass / stainless steel / zinc-plated steel
Seals	Urethane (standard) Fluorocarbon (optional, consult factory)

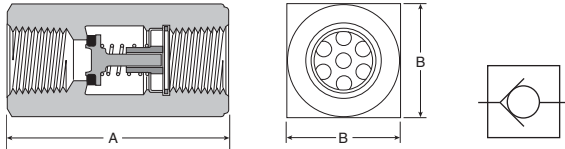

Operating information

Operating pressure: 250 PSIG max.
Cracking pressure 1 to 2 PSIG

Operating temperature: *
Standard: 0°F to 180°F
Extended Option: 0°F to 300°F (consult factory)

* Ambient temperatures below freezing require moisture-free air. Ambient temperatures below freezing and above 180° require lubricants especially selected for suitability at these temperatures. Pneumatic valves should be used with filtered and lubricated air.

339 Check Valve

Port size	Flow (SCFM †)	A	B	Part number	
				NPT	BSPP
1/8"	35	1.22	0.56	003393000	00339G3000
1/4"	75	1.34	0.69	003393001	00339G3001
3/8"	143	2.00	0.88	003393002	–
1/2"	162	2.56	1.19	003393003	–
3/4"	323	2.66	1.38	003393004	–

† At 100 PSIG inlet pressure with full pressure drop.

3047 Series Check Valves, 1/4" Ports

"3047" Series check valves allow free flow in one direction and provide positive checked flow in the reverse direction. This valve is available with a male 1/4" NPTF connection and is recommended for pneumatic service.



Material Specifications

Body	Brass
Internal Components	Brass / stainless steel
Seals	Nitrile

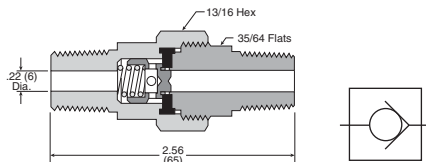

Operating information

Operating pressure: 250 PSIG max.
Cracking pressure 1 to 2 PSIG

Operating temperature: *
Standard: 0°F to 180°F

* Ambient temperatures below freezing require moisture-free air. Ambient temperatures below freezing and above 180° require lubricants especially selected for suitability at these temperatures. Pneumatic valves should be used with filtered and lubricated air.

3047 Check Valve

Port size	Flow (SCFM †)	Part number
1/4"	30	030470099

† At 100 PSIG inlet pressure with full pressure drop.

 Most popular.



For inventory, lead time, and kit lookup, visit www.pdnplu.com

EM Series – Sintered Bronze Muffler / Filters

Muffler / filters effectively reduce air exhaust noises to an industry accepted level with minimum flow restriction. They protect valves, impact wrenches, screw drivers and other air tools by preventing dirt and other foreign matter from entering the system. Non-corrosive. Can be cleaned with many common solvents.

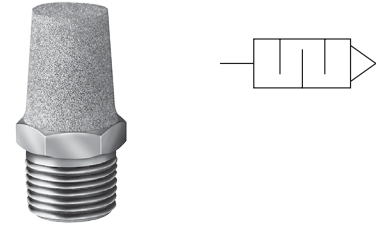

EM Series

Pipe thread	Overall length	Hex size	Part number
M5	.75	5/16"	EMM5
1/8"	1.00	7/16"	EM12
1/4"	1.32	9/16"	EM25
3/8"	1.54	11/16"	EM37
1/2"	1.85	7/8"	EM50
3/4"	2.29	1-1/6"	EM75
1"	2.91	1-5/16"	EM100
1-1/4"	3.25	1-11/16"	EM125
1-1/2"	3.69	2"	EM150

Operating information

Operating pressure: 250 PSIG (Air)
Cracking pressure 1 to 2 PSIG

Operating temperature:* 0°F to 300°F

* Ambient temperatures below freezing require moisture-free air. Ambient temperatures below freezing and above 180° require lubricants especially selected for suitability at these temperatures. Pneumatic valves should be used with filtered and lubricated air.

Muffler / Flow Controls

Muffler / flow controls provide an acceptable exhaust noise level and effectively meter exhaust. Installed in valve exhaust ports, they control cylinder piston speeds throughout a wide range. The adjusting screw cannot be accidentally blown out, can be locked to maintain setting. Brass and bronze construction. Clean with commonly used solvents.

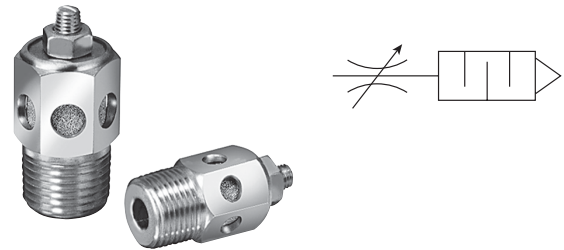

Muffler / Flow Controls

Pipe thread	Overall length	Hex size	Part number
1/8"	1.15	9/16"	045020002
1/4"	1.42	1/2"	045040004
3/8"	1.49	11/16"	045060060
1/2"	1.77	7/8"	045080080
3/4"	1.98	1-1/16"	045120012
1"	2.15	1-5/16"	045160016

Operating information

Operating pressure: 250 PSIG (Air)
Cracking pressure 1 to 2 PSIG

Operating temperature:* 0°F to 300°F

* Ambient temperatures below freezing require moisture-free air. Ambient temperatures below freezing and above 180° require lubricants especially selected for suitability at these temperatures. Pneumatic valves should be used with filtered and lubricated air.

Most popular.



For inventory, lead times, and kit lookup, visit www.pdnplu.com

Breather Vents

These low silhouette versions of the muffler / filter are useful where space is a problem and / or to prevent contamination. Use for vacuum relief or pressure equalization in gear boxes, oil tanks, reservoirs, etc. Non-corrosive.

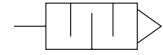

Breather Vent

Pipe thread	Overall length	Hex size	Part number
1/8"	0.44	7/16"	047020002
1/4"	0.63	9/16"	047040004
3/8"	0.75	11/16"	047060006
1/2"	0.88	7/8"	047080008
3/4"	1.00	1-1/6"	047120012
1"	1.31	1-5/16"	047160016
1-1/4"	1.41	1-11/16"	047200020
1-1/2"	1.50	2"	047240024

NOTE: Breather vents should not be used as exhaust mufflers.

Operating information

Operating pressure: 150 PSIG (Air) max.

Operating temperature:* 0°F to 300°F

* Ambient temperatures below freezing require moisture-free air. Ambient temperatures below freezing and above 180° require lubricants especially selected for suitability at these temperatures. Pneumatic valves should be used with filtered and lubricated air.

ES Series – Silencer

The silencer is designed to give superior performance in noise control with a minimum effect on air efficiency. "Trimline" design allows location in the tightest places without extra plumbing and fittings. Fits directly into the exhaust port of more than 90% of present commercial valves. Slotted body permits rapid discharge of air without undesirable back pressure. Unique nylon screen element resists dirt buildup or clogging.

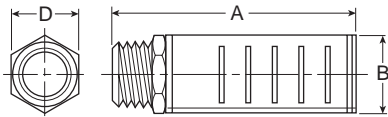

Operating information

Operating pressure: 250 PSIG (Air) max.

Operating temperature:* 0°F to 300°F

* Ambient temperatures below freezing require moisture-free air. Ambient temperatures below freezing and above 180° require lubricants especially selected for suitability at these temperatures. Pneumatic valves should be used with filtered and lubricated air.

ES Series – Silencer

Pipe thread	Flow SCFM @ 100 PSIG inlet	Dimensions			Part numbers	
		A	B	D	NPTF	BSPT (R)
1/8"	115	1.85	0.81	0.63	ES12MC	ESB12MC
1/4"	129	1.85	0.81	0.63	ES25MC	ESB25MC
3/8"	219	3.31	1.26	1.00	ES37MC	ESB37MC
1/2"	549	3.31	1.26	1.00	ES50MC	ESB50MC
3/4"	893	4.56	2.01	1.62	ES75MC	ESB75MC
1"	1,013	4.56	2.01	1.62	ES100MC	ESB100MC
1-1/4"	1,486	5.69	2.88	—	ES125MC	ESB125MC
1-1/2"	1,580	5.69	2.88	—	ES150MC	ESB150MC

Most popular.



For inventory, lead time, and kit lookup, visit www.pdnplu.com

Stainless Steel Mufflers

Corrosion resistant mufflers for harsh environments

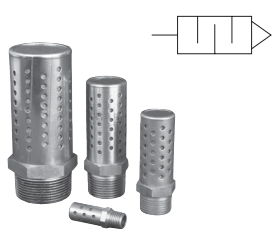

Port size	Construction	Threads	Dimensions In. (mm)		Part number
			Width	Length	
1/4	Stainless steel	Male, NPT	0.56 (14.2)	1.75 (44.5)	5500A2004
1/2	Stainless steel	Male, NPT	0.87 (22.1)	2.75 (69.7)	5500A4004
1	Stainless steel	Male, NPT	1.31 (33.3)	3.87 (98.3)	5500A6004
2	Nickel plated	Male, NPT	2.37 (60.2)	5.50 (139.7)	5500A9004*

* Nickel plated

Flow Controls
& Check Valves

Misc
Accessories

Integrated
Fittings

Accessories



ASN Air Line Silencer, Plastic

- Compact
- Lightweight
- Easy to Install
- Excellent Noise Reduction
- Protects Components from Contamination
- NPT and BSPT Threads Available

The plastic silencer is designed to give excellent noise reduction with a minimum effect on air efficiency. The "Trimline" design allows for locating the silencer in the tightest places without extra plumbing or fittings. Fits directly into the exhaust port of most commercial valves. Open surface area of element allows for rapid discharge of air without undesirable back pressure.

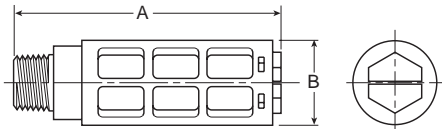

Operating information

Operating pressure:	0 to 150 PSIG (0 to 10 bar, 0 to 1034 kPa)
Operating temperature:	14°F to 140°F (-10°C to 60°C)

Material Specifications

Body	Acetal (Plastic)
Element	Polyethylene

ASN Air Line Silencer, Plastic

Thread size	A (mm)	B (mm)	Maximum flow (SCFM) 100 PSIG inlet	Sound pressure level (dBA)		Part number	
				20 PSIG inlet	100 PSIG inlet	NPT	BSPT
M5	0.43 (11)	0.32 (8)	15	69	79	AS-5	
1/8"	1.57 (40)	0.63 (16)	51	69	81	ASN-6	AS-6
1/4"	2.56 (65)	0.83 (21)	124	67	84	ASN-8	AS-8
3/8"	3.35 (85)	0.98 (25)	247	83	98	ASN-10	AS-10
1/2"	3.74 (95)	1.18 (30)	370	69	96	ASN-15	AS-15

Most popular.



For inventory, lead time, and kit lookup, visit www.pdnplu.com

P6M G Thread Air Line Silencer, Plastic

- All Plastic Ultra Light Weight Versions
- High Noise Level Reduction
- Low Back Pressure Generation

The plastic silencer is designed to give excellent noise reduction with a minimum effect on air efficiency. The “Trimline” design allows for locating the silencer in the tightest places without extra plumbing or fittings. Fits directly into the exhaust port of most commercial valves. Open surface area of element allows for rapid discharge of air without undesirable back pressure.

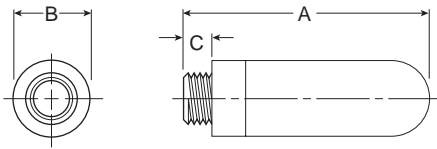
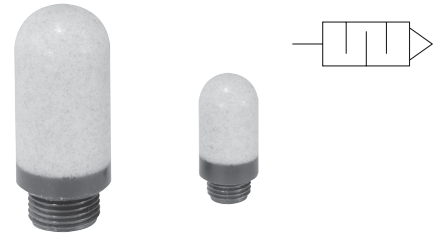

Operating information

Operating pressure:	0 to 246 PSIG (0 to 17 bar, 0 to 1700 kPa)
Operating temperature:	14°F to 176°F (-10°C to 80°C)
Plastic	14°F to 165°F (-10°C to 74°C)
Metal	
Efficiency	92%

P6M G Thread, Air Line Silencer, Plastic

Port thread	A	Diameter B	C	Weight (grams)	Part number
M5	0.91 (23)	0.26 (6,5)	0.16 (4)	0.01	P6M-PAC5
G1/8	1.14 (29)	0.55 (14)	0.24 (6)	0.02	P6M-PAB1
G1/4	1.34 (34)	0.67 (17)	0.24 (6)	0.04	P6M-PAB2
G3/8	2.36 (60)	0.98 (25)	0.35 (9)	0.06	P6M-PAB3
G1/2	2.52 (64)	0.98 (25)	0.43 (11)	0.10	P6M-PAB4
G3/4	5.51 (140)	1.50 (38)	0.55 (14)	0.50	P6M-PAB6
G1	6.30 (160)	1.89 (48)	0.79 (20)	0.62	P6M-PAB8

Most popular.



For inventory, lead times, and kit lookup, visit www.pdnplu.com

Flow Controls
& Check Valves

Misc
Accessories

Integrated
Fittings

Accessories



ECS Reclassifier, Air Line Muffler

The ECS (Muffler-Reclassifier) eliminates unwanted oil mist and reduces exhaust noise from pneumatic valves, cylinders and air motors.

- 99.97% Oil Removal Efficiencies
- 25 dBA Noise Attenuation
- 1/2" NPT and 1" NPT
- Disposable Units
- Continuous or Plugged Drain Option
- Metal Retained Construction
- Fast Exhaust Time

Improve Overall Plant Environment

Exhaust oil mist and noise pollution have a direct impact on worker productivity.

Oil aerosol mist from lubricators and compressors is pervasive and enters the industrial plant environment through the exhaust ports of valves, cylinders and air motors. This rapidly expanding exhaust also produces sudden and excessive noise.

The ECS (Muffler-Reclassifier) is 99.97% efficient at removing the oil aerosols. The ECS also acts as a silencer to lower the dBA levels below O.S.H.A. requirements.

The result is a cleaner, quieter environment which equates to greater work productivity and safety.

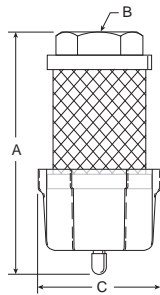

ECS Reclassifier, Air Line Muffler

Thread size	A	B	C	Part number
1/2	5.30 (135 mm)	1/2" NPT	2.57 (65 mm)	ECS3
1	7.30 (185mm)	1" NPT	2.57 (65mm)	ECS5

Performance Characteristics

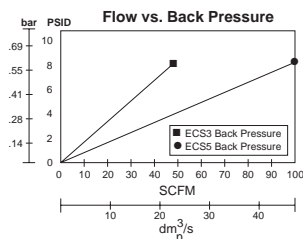
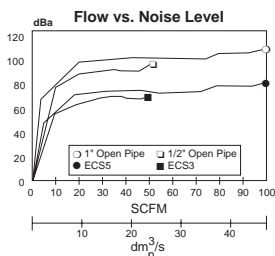

Most popular.



Operating information

Maximum line pressure:	100 PSIG (6.8 bar)
Maximum operating temperature:	125°F (52°C)

Operation

Compressor oils and lubricating oils are exhausted from valves, cylinders and air motors into the ECS. Oil aerosols are "coalesced" into larger droplets and gravity pulls them into the attached drain sump. The sump can then be drained manually or by using a 1/4" ID plastic tube drain. The air flowing into the ECS is also muffled or silenced as it enters the inside of the ECS and passes through the filter media into the atmosphere.

Proven Technology

The ECS units are constructed from the same materials that go into our oil removal coalescing filter elements.

The seamless design insures media uniformity and strength. This proven technology provides high coalescing efficiency with low pressure drop.

The filter media is supported by cylindrical perforated steel retainers both inside and out. These retainers, fully plated for excellent corrosion resistance, give the ECS units high rupture strength in either flow direction. These filters can also be used as high efficiency inlet or bypass filters for vacuum pumps, or breather elements to protect the air above critical process liquids.

ECS3 / ECS5

The ECS solves two problems inherent in compressed air exhaust from valves, cylinders and air motors - oil mist removal and noise abatement.

The ECS will improve your industrial plant environment, thereby improving worker productivity.

Flow Controls
& Check Valves

Misc
Accessories

Integrated
Fittings

Accessories



OR Series Quick Exhaust & Shuttle Valves

Quick exhaust valves provide rapid exhaust of control air when placed between control valve and actuator. They can also be used as shuttle valves. Diaphragm materials are available in urethane, Nitrile, Fluorocarbon, and PTFE to meet a wide variety of operating conditions.

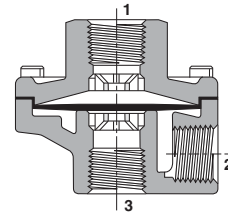

Material Specifications

Body	Die cast aluminum
Static Seals	Nitrile standard with urethane (Others see chart below)
Diaphragm	Standard – Urethane Optional – Fluorocarbon, PTFE, or Nitrile (Depending on size)

Operating information

Operating pressure (Air): 150 PSIG (max), 3 PSIG (min)
200 PSIG (max), 50 PSIG (min) for Model No. OR37TB (PTFE diaphragm)

Operating temperature:*

- Urethane: 0°F to 180°F (-18°C to 80°C)
- Nitrile: 0°F to 180°F (-18°C to 80°C)
- Fluorocarbon: 0°F to 400°F (-18°C to 205°C)
- PTFE: 0°F to 500°F (-18°C to 260°C)

* Ambient temperatures below freezing require moisture-free air. Ambient temperatures below freezing and above 180° require lubricants especially selected for suitability at these temperatures. Pneumatic valves should be used with filtered and lubricated air.

Mounting Bracket Kit – No. 036408100

(Including body screws)

For “OR12” and “OR25” sizes with 7/8” “A” Dimension.

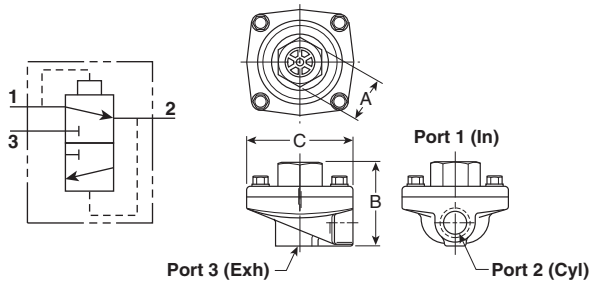
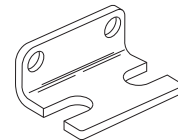

Model Selection, Performance Data and Dimensions

Port 1	Port 2	Port 3	Flow (SCFM †)	Part Number		A	B	C	Service Kit No.
				NPTF	BSPP “G”				
STANDARD Urethane diaphragms (Nitrile static seals)									
1/4"	1/4"	3/8"	150	OR25NB	ORB25NB	1" Hex	2.06	2.44	033400105
	3/8"	3/8"	240	OR25PB	—	1" Hex	2.06	2.44	033400105
3/8"	3/8"	3/8"	240	OR37B	ORB37B	1" Hex	2.06	2.44	033400105
1/2"	1/2"	1/2"	450	OR50B	ORB50B	1-1/2" Hex	2.88	3.38	034750109
3/4"	3/4"	3/4"	550	OR75B	ORB75B	1-1/2" Hex	2.88	3.38	034750109
Nitrile diaphragms (Nitrile static seals)									
1/8"	1/8"	1/8"	70	OR12B	ORB12B	7/8" Sq.	1.75	1.88	033400105
	1/8"	1/4"	70	OR12NB	ORB12NB	7/8" Sq.	1.75	1.88	033400105
1/4"	1/4"	1/4"	90	OR25B	ORB25B	7/8" Sq.	1.75	1.88	036408000
	1/4"	3/8"	90	OR25NFB	ORB25NFB	1" Hex	2.06	2.44	033408000
3/8"	3/8"	3/8"	240	OR37FB	ORB37FB	1" Hex	2.06	2.44	033408000
3/4"	3/4"	3/4"	550	OR75FB	ORB75FB	1-1/2" Hex	2.88	3.38	034759000
Fluorocarbon diaphragms for extended temperature operation (Fluorocarbon static seals)									
1/8"	1/8"	1/8"	70	OR12VB	ORB12VB	7/8" Sq.	1.75	1.88	036508000
	1/8"	1/4"	70	OR12NVB	ORB12NVB	7/8" Sq.	1.75	1.88	036508000
1/4"	1/4"	1/4"	90	OR25VB	ORB25VB	7/8" Sq.	1.75	1.88	036508000
3/8"	3/8"	3/8"	240	OR37VB	ORB37VB	1" Hex	2.06	2.44	033400319
1/2"	1/2"	1/2"	450	OR50VB	ORB50VB	1-1/2" Hex	2.88	3.38	034750120
3/4"	3/4"	3/4"	550	OR75VB	ORB75VB	1-1/2" Hex	2.88	3.38	034750120
PTFE diaphragms for higher pressure and temperature (Fibre static seals)									
3/8"	3/8"	3/8"	240	OR37TB	ORB37TB	1" Hex	2.06	2.44	033400504

† At 100 PSIG inlet pressure with full pressure drop.

Most popular.



For inventory, lead times, and kit lookup, visit www.pdnplu.com

Shuttle Valves

Shuttle valves determine a single pneumatic output from two separate inputs. If pressure is applied to both ports simultaneously, the valve will select the port with the higher pressure.



Material Specifications

Body	Aluminum
Internal Components	Aluminum
Seals	Nitrile

Operating information

Operating pressure:
 Maximum: 200 PSIG
 Minimum: Differential Pressure 3 PSIG

Operating temperature:* 0°F to 160°F

* Ambient temperatures below freezing require moisture-free air. Ambient temperatures below freezing and above 180° require lubricants especially selected for suitability at these temperatures. Pneumatic valves should be used with filtered and lubricated air.

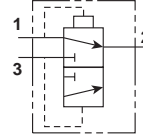
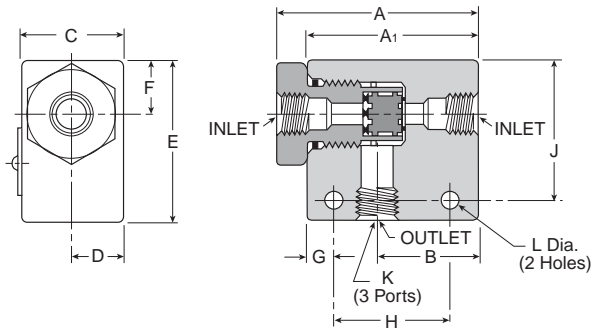

Model Selection and Dimensions

Port size	Flow (Cv)	Dimensions											Part number	
		A	A1	B	C	D	E	F	G	H	J	K		L
1/8"	0.32	N/A	1.62	0.81	0.62	0.31	1.00	0.281	0.312	1.00	0.75	1/8 - 27	0.219	N1641001
1/4"	1.65	2.50	2.12	1.25	1.25	0.62	2.00	0.67	0.265	1.25	1.35	1/4 - 18	0.219	N1642003
3/8"	2.02	2.50	2.12	1.25	1.25	0.62	2.00	0.67	0.265	1.25	1.35	3/8 - 16	0.219	N1643003

Most popular.



For inventory, lead time, and kit lookup, visit www.pdnplu.com



Typical “Quick Exhaust Valve” Applications

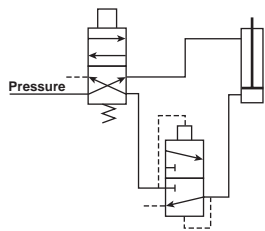

Rapid Retraction – Double Acting Cylinder

In this circuit, air is exhausted through a Quick Exhaust Valve that is **close coupled** to the cap end of the cylinder. Because the Quick Exhaust Valve has a greater exhaust capacity than the four-way Control Valve, increased cylinder speed can be accomplished with a smaller and less expensive control valve.

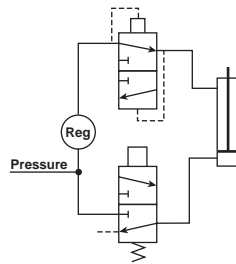

Dual Pressure Actuation of Double Acting Cylinder

This circuit utilizes a Quick Exhaust Valve and a three-way Control Valve to permit rapid extension of the cylinder at a high pressure.

NOTE: Line pressure must be 3 or 4 times greater than rod end pressure. Effective working pressure is the differential between the cap and rod end.

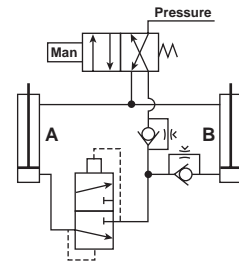

Bi-Directional Control of Two Double Acting Cylinders

This circuit provides maximum control with a minimum of valving. A large four-way Control Valve is not needed to permit the rapid retraction of Cylinder A, as the Quick Exhaust Valve performs this function. The extension of Cylinders A and B and retraction of Cylinder B are controlled by Speed Control Valves.

Flow Controls & Check Valves

Misc Accessories

Integrated Fittings

Typical “Shuttle Valve” Applications

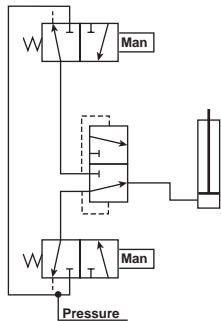

“OR” Circuit

The most common application of the Shuttle Valve is the “OR” Circuit. Here a cylinder or other work device can be actuated by either control valve. The valves can be manually or electrically actuated and located in any position.

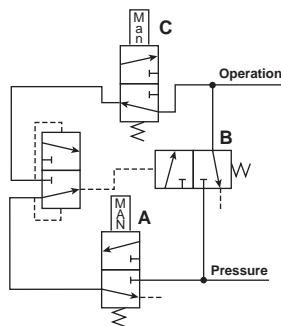

Memory Circuit

This circuit enables continuous operation once initiated. Pressure is delivered to the circuit when Valve A is actuated. This allows pressure to pass through the shuttle valve actuating Valve B. Pressure then flows through Valve B and also the other side of the shuttle valve which holds Valve B open for continuous operation. To unlock the circuit, Valve C must be opened to exhaust the circuit and allow Valve B to return to its normally closed position.

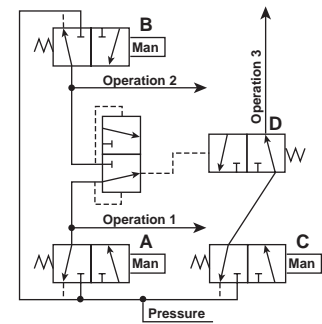

Interlock

This circuit prevents the occurrence of a specific operation while one or another operation takes place. When either Valve A or B is actuated to perform operation 1 or 2, Valve D is shifted to the closed position and prevents operation 3 from occurring.

Accessories



Blocking Valves

The blocking valve is a single acting spring return 2/2 valve in a fitting format. The device requires a pneumatic pilot signal to open, which allows free flow of air or neutral gas. As long as a pilot signal is present, the device will remain open. When the pilot signal is removed, the internal spring will close the blocking valve, bubble tight.

These devices have two primary design uses: (1) to prevent unwanted gravity induced motion in cylinders during shut down procedures or during periods of lost supply pressure and (2) freezing the cylinder position by using a blocking valve at each end of the cylinder. Application needs such as tool or work piece protection, horizontal indexing or inspection stops are often satisfied by these devices.

Material specifications

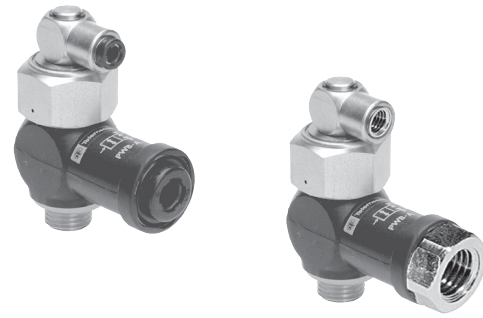

Body Zinc alloy





Operating information

Operating pressure: 0 to 150 PSIG (0 to 10.3 bar)
 Operating temperature:
 Operating 5°F to 140°F (-15°C to 60°C)
 Storage -40°F to 160°F (-40°C to 70°C)

For Cylinder Mounting (Can also be mounted in Threshold Sensor Banjo) With Instant Tube Fittings

BSPP				NPT				
Symbol	Connection for pilot	Cylinder port thread (male)	Connection for tube	Part number	Connection for pilot	Cylinder port thread (male)	Connection for tube	Part number
  4mm Tube PWBA3469		1/8"	6mm	PWBA1468	5/32" Tube	1/8"	1/4"	PWBA3468
		1/4"	6mm	PWBA1469		1/4"	1/4"	PWBA3469
		1/4"	8mm	PWBA1489		3/8"	3/8"	PWBA3493
		3/8"	8mm	PWBA1483		1/2"	1/2"	PWBA3412
		3/8"	10mm	PWBA1493				
		1/2"	12mm	PWBA1412				

With Threaded Connections and Tube Pilot Port

BSPP				NPT				
Symbol	Connection for pilot	Cylinder port thread (male)	Connection from valve (female)	Part number	Connection for pilot	Cylinder port thread (male)	Connection from valve (female)	Part number
  4mm Tube M5 Female PWBA3833		1/8"	1/4"	PWBA1898	5/32" * Tube	1/8"	1/8"	PWBA3888
		1/4"	1/4"	PWBA1899		1/4"	1/4"	PWBA3899
		3/8"	3/8"	PWBA1833		3/8"	3/8"	PWBA3833
		1/2"	1/2"	PWBA1822		1/2"	1/2"	PWBA3822

* Instant fitting

With Threaded Connections and Threaded Pilot Port

NPT			
Connection for pilot	Cylinder port thread (male)	Connection from valve	Part number
1/8" pipe	1/8"	1/8"	PWBA38887
	1/4"	1/4"	PWBA38997
	3/8"	3/8"	PWBA38337
	1/2"	1/2"	PWBA38227

 Most popular.



For inventory, lead time, and kit lookup, visit www.pdnplu.com

Flow Controls
 & Check Valves
 Misc
 Accessories
 Integrated
 Fittings
 Accessories

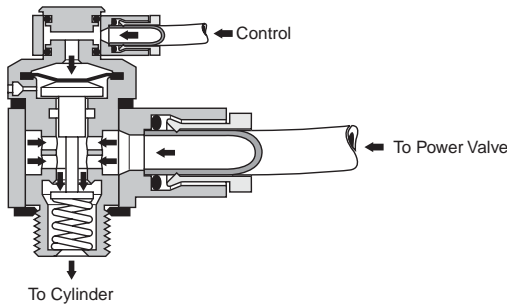
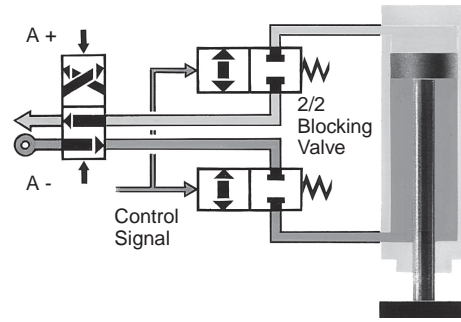
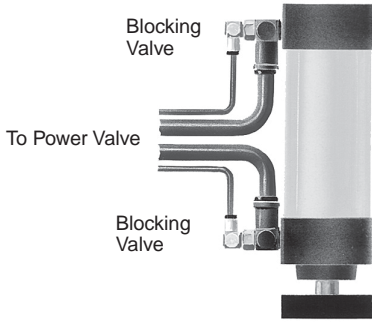

PWBA General Characteristics

Permissible Fluids	Air or neutral gas, 50 µm filtration, lubricated or not
Mechanical Life	10 Million
Maximum Operating Frequency	10Hz
Mounting Screw	Brass
Maximum Mounting Torque:	88 inch pounds
10-32 UNF and M5	
1/8"	70 inch pounds
1/4"	105 inch pounds
3/8"	265 inch pounds
1/2"	310 inch pounds
Adjustment	N/A
Adjustment Locking	N/A
Air Quality – Standard Shop Air, Lubricated or Dry 40 µm Filtration	

Piloting and De-Piloting Pressure

Blocking Valve Sizes	Pilot with Operating Pressure of:			
	30 PSI	60 PSI	90 PSI	120 PSI
1/8" BSP or NPT	33 PSI	40 PSI	45 PSI	50 PSI
1/4" BSP or NPT	33 PSI	40 PSI	45 PSI	50 PSI
3/8" BSP or NPT	35 PSI	40 PSI	45 PSI	50 PSI
1/2" BSP or NPT	45 PSI	50 PSI	55 PSI	60 PSI

Blocking Valve Sizes	Depilot with Operating Pressure of:			
	30 PSI	60 PSI	90 PSI	120 PSI
1/8" BSP or NPT	20 PSI	25 PSI	30 PSI	34 PSI
1/4" BSP or NPT	20 PSI	25 PSI	30 PSI	34 PSI
3/8" BSP or NPT	20 PSI	25 PSI	30 PSI	34 PSI
1/2" BSP or NPT	25 PSI	30 PSI	34 PSI	40 PSI



For inventory, lead times, and kit lookup, visit www.pdnplu.com

Threshold Sensors

The plug-in threshold sensors provide feedback information on pneumatic cylinder status in either pneumatic or electrical outputs. Mounted into the cylinder port, these devices monitor the back pressure of the cylinder's exhaust. When the cylinder's piston stops, the back pressure rapidly drops and the threshold sensor provides the desired output. Ideal for variable stroke applications such as robotics where other sensor type devices such as limit switches are impractical, these devices provide a signal whenever the cylinder stops motion.

The threshold sensor consists of two complementary sub assemblies (1) the banjo fitting and (2) the plug-in sensor element. In all cases, the sensor is easily plugged into the banjo fitting and locked in place with a spring clip. The banjo fitting is designed to accept (piggy backed) other functional fittings such as flow controls or blocking valves. Simply select the sensor based on the type feedback signal that best fits the application.

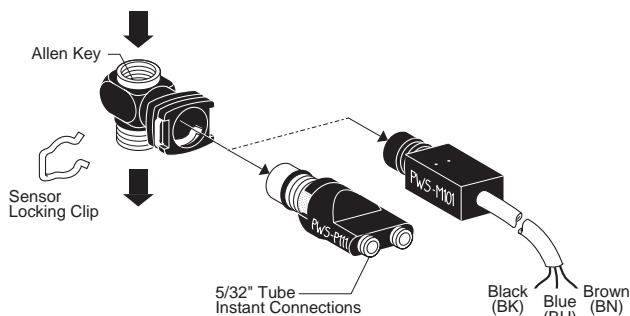

Material specifications

Body	Thermoplastic
Mounting screw	Brass

Banjo Sockets (with Sensor Clip)

Port size	Wrench	Part number
10-32	5/16" Hex	PWSB1557
1/8"	3/16" Allen	PWSB1887
1/4"	5/16" Allen	PWSB1997
3/8"	3/8" Allen	PWSB1337
1/2"	1/2" Allen	PWSB1227



Plug-in Sensors

Output	Connection	Part number
Pneumatic	5/32" push-in	PWSP111
Electrical	3-wire cable (6 ft)	PWSM1012

Most popular.



Operating information

Operating pressure: 0 to 150 PSIG (0 to 10.3 bar)
 Operating temperature:
 Operating 5°F to 140°F (-15°C to 60°C)
 Storage -40°F to 160°F (-40°C to 70°C)

Caution: If it is possible that the ambient temperature may fall below freezing, the medium must be moisture free to prevent internal damage or unpredictable behavior.

Mounting

Banjo fittings in 10-32 to 1/2" pipe sizes are designed to be installed directly into actuator ports (up to 5" bore cylinders). The banjo fitting can accommodate other functional fittings and components such as right angle flow control valves or blocking valves. Banjo fittings screw into actuators using an Allen wrench or 5/16" hex head wrench for 10-32 size. Electrical or pneumatic feedback element snaps into place using a locking clip.

Operation

Pneumatic sensors have a continuous pressure signal applied to the sensor device. Electrical sensors have a continuous electrical signal applied to the sensor device. The threshold sensor assembly mounted directly into the cylinder Port provides an output signal S, which can be pneumatic or electrical, when the falling back pressure in the exhausting chamber of the cylinder reaches the operating threshold (approximately 6-9 PSIG). (The device is a normally passing device. The output is only on when there is nearly zero pressure at the cylinder.)

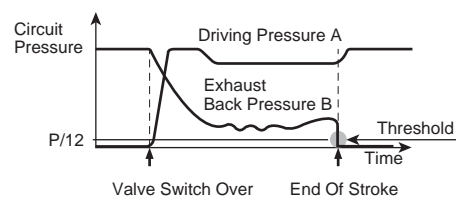

Flow Controls & Check Valves

Misc Accessories

Integrated Fittings

Accessories



For inventory, lead time, and kit lookup, visit www.pdnplu.com

Specifications

Maximum Operating Frequency	10 Hz
Pilot Pressure (PWSP111)	>64 PSIG (4.4 bar)
Threshold Pressure	6 to 9 PSIG (.4 to .6 bar)
Output Flow Rate (PWSP111)	3 SCFM at 90 PSIG
Current Rating (PWSM1012) –	5 VA, 250 VAC 5W, 48 VAC
Life Expectancy –	10 million cycles with dry air at 90 PSIG, 68°F, and 1 Hz operating frequency
Voltage Range (PWSM1012) –	12 - 240 VAC 12 - 48 VDC

Air Quality – Standard Shop Air, Lubricated or Dry 40 µm Filtration

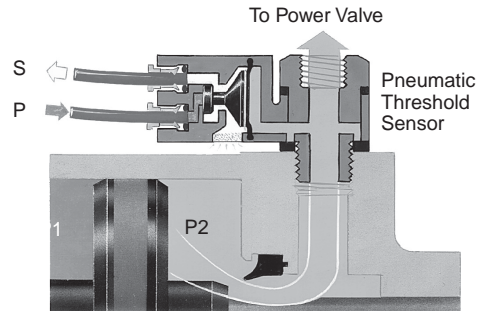
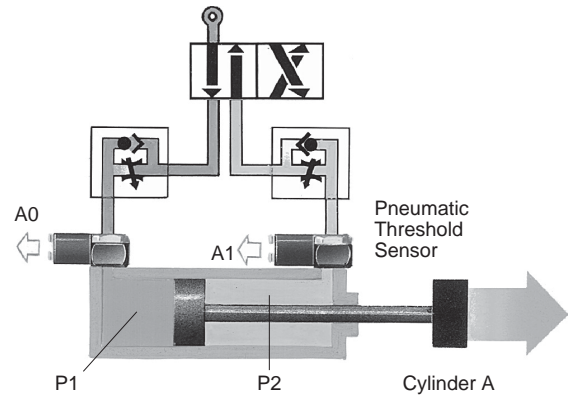
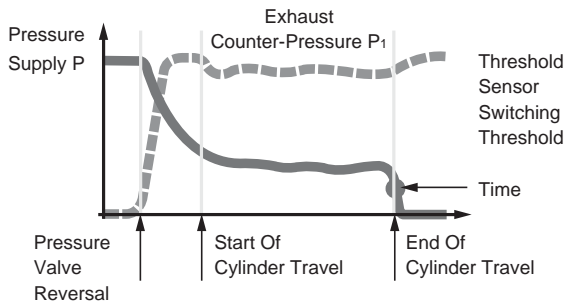

PWS General Characteristics

Permissible Fluids	Air or neutral gas, 50 µm filtration, lubricated or not
Flow	N/A
Mechanical Life	10 Million
Maximum Operating Frequency	10Hz
Maximum Mounting Torque:	
10-32 UNF and M5	88 inch pounds
1/8"	70 inch pounds
1/4"	105 inch pounds
3/8"	265 inch pounds
1/2"	310 inch pounds
Adjustment	N/A
Adjustment Locking	N/A

Piloting and De-Piloting Pressure

Threshold sensors	Pilot with operating pressure of 90 PSI	Depilot with operating pressure of 90 PSI
PWSP111	64 PSI	6 PSI
PWSM1012	15 PSI	9 PSI
PWSE101 and PWSE111	10 PSI	7 PSI

Flow Controls
& Check Valves

Misc
Accessories

Integrated
Fittings

Accessories



Fluid Power		Universal Description	Electrical	
Function	Symbol		Function	Symbol
Normally Closed (N.C.)	2-Way	Normally Non-Passing (NNP)	Normally Open (N.O.)	
	3-Way			
Normally Open (N.O.)	2-Way	Normally Passing (NP)	Normally Closed (N.C.)	
	3-Way			



For inventory, lead times, and kit lookup, visit www.pdnplu.com

Blocking Valves

PWBA14/34

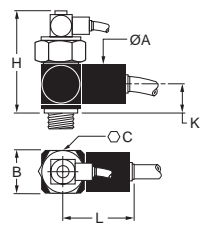

ØA	B	C	K	H	L	Flow*	Part number
0.86" (22)	0.82" (21)	0.94" (24)	0.53" (13.5)	2.32" (59)	1.54" (39)	14.8	PWBA1468/3468
0.86" (22)	0.82" (21)	0.94" (24)	0.53" (13.5)	2.09" (53)	1.54" (39)	19.4	PWBA1469/3469 PWBA1489
1.06" (27)	1.10" (28)	0.94" (24)	0.55" (14)	2.09" (53)	1.98" (50)	45.9	PWBA1483 PWBA1493/3493
1.22" (31)	1.30" (33)	1.30" (33)	0.94" (24)	2.59" (66)	2.59" (66)	81.2	PWBA1412/3412

PWBA18/38

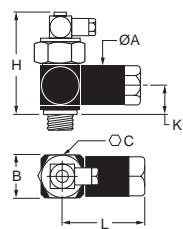

0.86" (22)	0.82" (21)	0.94" (24)	0.53" (13.5)	2.32" (59)	1.71" (43.5)	14.8	PWBA1898/3888
0.86" (22)	0.82" (21)	0.94" (24)	0.53" (13.5)	2.09" (53)	1.71" (43.5)	19.4	PWBA1899/3899
1.06" (27)	1.10" (28)	0.94" (24)	0.55" (14)	2.09" (53)	2.18" (55)	45.9	PWBA1833/3833
1.22" (31)	1.30" (33)	1.30" (33)	0.94" (24)	2.59" (66)	2.47" (63)	81.2	PWBA1822/3822

PWBA38

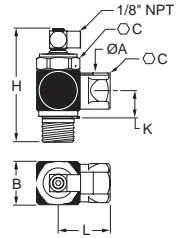

0.75" (19)	0.87" (22)	0.83" (21)	0.67" (17)	2.20" (56)	1.73" (44)	14.8	PWBA38887
0.75" (19)	0.87" (22)	0.83" (21)	0.67" (17)	2.20" (56)	1.73" (44)	19.4	PWBA38997
1.06" (27)	1.18" (30)	1.06" (27)	0.91" (23)	2.64" (67)	1.42" (36)	45.9	PWBA38337
1.06" (27)	1.18" (30)	1.06" (27)	0.91" (23)	2.64" (67)	1.42" (36)	81.2	PWBA38227

Threshold Sensors

Banjo Socket

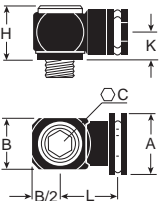

A	B	C	H	K	L	Part number
.98 (25)	.43 (11)	5/16" Hex	.79 (20)	.40 (10)	.67 (17)	PWSB1557
.98 (25)	.63 (16)	3/16" Allen	.71 (18)	.40 (10)	.79 (20)	PWSB1887
.98 (25)	.83 (21)	5/16" Allen	.71 (18)	.40 (10)	.87 (22)	PWSB1997
.98 (25)	1.10 (28)	3/8" Allen	.79 (20)	.47 (12)	.98 (25)	PWSB1337
.98 (25)	1.30 (33)	1/2" Allen	.93 (24)	.55 (14)	1.02 (26)	PWSB1227

PWSP111

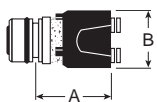

A	B	Part number
.87 (22)	.79 (20)	PWSP111
1.26 (32)	.79 (20)	PWSM1012

PWSM1012



Flow Controls
& Check Valves

Misc
Accessories

Integrated
Fittings

Accessories



Tank Valves

For tanks, steel barrels, compressors and other pneumatic containers where a dependable automatic air valve is needed. Equipped with standard valve core and sealing cap. Maximum operating pressure is 185 PSIG. Temperature range is -40°F to 220°F.

091660060, 1/8" pipe thread, dome shaped cap

Has a 1/8" pipe thread at bottom for minimum protrusion. N/P finish, dome shaped cap.

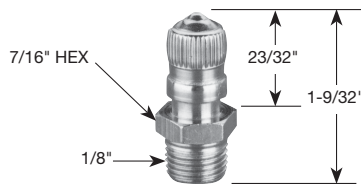

Thread size	Box qty	Part number
1/8	25	091660060

014680006, 1/8" pipe thread part way up the stem, screwdriver type cap

Has a 1/8" pipe thread part way up the stem which allows for minimum protrusion. N/P finish, has screwdriver type cap.

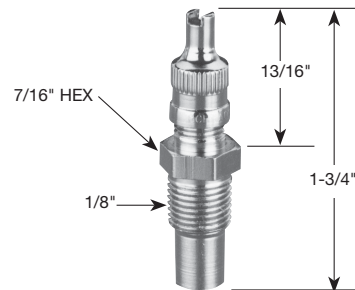

Thread size	Box qty	Part number
1/8	25	014680006

006450060, 1/8" pipe thread at bottom, screwdriver type cap

A 1/8" pipe thread at bottom permits maximum protrusion. N/P finish, screwdriver type cap.

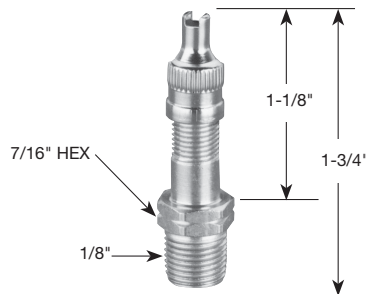

Thread size	Box qty	Part number
1/8	25	006450060

Most popular.



For inventory, lead times, and kit lookup, visit www.pdnplu.com

Flow Controls
 & Check Valves

Misc
 Accessories

Integrated
 Fittings

Accessories



O.S.H.A. Certification — All safety blow guns conform to the requirements of Compressed Air Standards as currently described in the U.S. Bureau of Labor Standards, paragraph 1910.242, when pressurized at the inlet to a maximum of 100 PSIG. Conform to current O.S.H.A. Directive No. 100-1.

Brass Nozzle Blow Guns

Contoured lever or button control both provide a natural, comfortable grip even when used with gloves. Finger guard and hang-up hook for finger protection and quick safe storage. Die cast zinc body, painted finish.

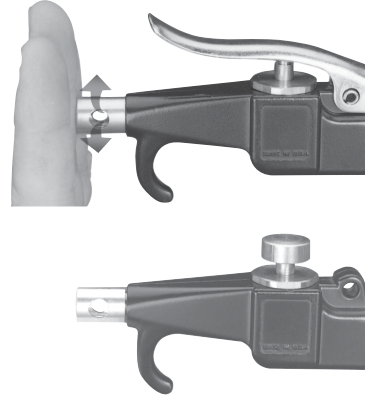

Brass Nozzle Blow Gun

Type	Inlet port	SCFM rating*	Part number
Lever operated	1/4	20	004750010
Button operated	1/4	20	004700010

* Based on 100 PSIG inlet pressure.

Flow Controls
& Check Valves

Misc
Accessories

Integrated
Fittings

Accessories



Vortec FLO-GAIN Blow Guns

A quiet Vortec FLO-GAIN nozzle is combined with a high performance blow gun. Compressed air attains sonic velocity through an adjustable slot and attaches to the exterior surface of the cone shaped nozzle. Settings are shown on a micrometer dial. Sound level of 80 dBA with 80 PSIG inlet. Finger guard and hang-up hook offers desirable finger protection and quick secure storage. Die cast zinc body, painted finish.

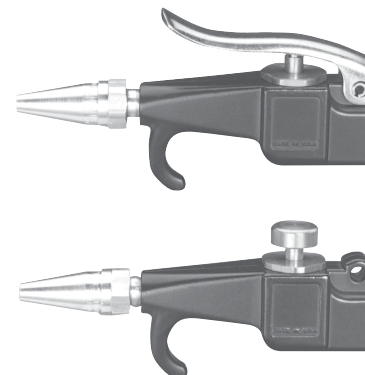

Vortec FLO-GAIN Blow Gun

Type	Inlet port	SCFM rating*	Part number
Lever operated	1/4	70+	004750900
Button operated	1/4	70+	004700900

* Based on 100 PSIG inlet pressure.

Self-Regulating Blow Gun

Designed with integral self-regulating pressure reducing valve for automatic shut-off when nozzle is blocked. Prevents air pressure buildup over 30 PSIG in compliance with U.S. Dept. of Labor standards.

Air shield aids in protecting the operator against blow back of flying chips of dirt. Designed to operate at less than 90 dBA to comply with government regulations. Die cast zinc body, painted finish.



Self-Regulating Blow Gun

Type	Inlet port	SCFM rating*	Part number
Lever operated	1/4	10	004750010

* Based on 100 PSIG inlet pressure.

 Most popular.

Performance Data

Inlet Pressure	Blocked Pressure	Sound Level
70 PSIG	17.0 PSIG	79 dBA
100 PSIG	21.0 PSIG	83 dBA
175 PSIG	28.0 PSIG	87 dBA



For inventory, lead time, and kit lookup, visit www.pdnplu.com

Brass Nozzle

004707020

General purpose nozzles are supplied as standard on 004700010 and 004750010 blow guns. Conform to the requirements of the Williams Steiger Occupational Safety and Health Act of 1970, paragraph 1910.242 when fitted with blow guns pressurized at the inlet to a maximum of 100 PSIG. Conform to O.S.H.A. Directive 100-1.

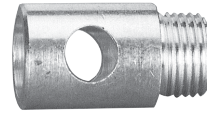

	Part number
Brass Nozzle	004707020

470 and 475 Series Blow Guns

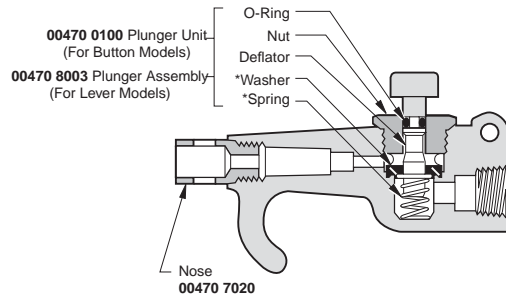

* Contained in Service Kit No. **00470 0090**

Flow Controls
& Check Valves

Misc
Accessories

Integrated
Fittings





























Accessories



Most popular.



For inventory, lead times, and kit lookup, visit www.pdnplu.com

Compact Flow Control Valves	FCC731 Meter Out  Page F27	FCC731 Meter Out - BSPP  Page F27	FCCB731 Bi-Directional Flow Control  Page F27	FCCB731 Bi-Directional Flow Control - BSPP  Page F27	FCCK731 Knobless Meter Out Flow Control  Page F28
	FCCK731 Knobless Flow Control - BSPP  Page F28	FCCKB731 Knobless Bi-Directional Flow Control - BSPP  Page F28	Miniature Flow Control Valves	FCM731 Meter Out Flow Control  Page F29	FCM731 Flow Control - BSPP  Page F29
FCMK731 Knobless Mini Meter Out Flow Control  Page F29	Swivel Outlet Flow Control Valves	FCCS731 Compact Swivel Outlet Flow Control  Page F30		FCMS731 Mini Swivel Outlet Flow Control  Page F30	FCMS731 Miniature Swivel Outlet - BSPP  Page F30
Plug-In Flow Control Valves		FCMSP731 Mini Flow Control  Page F31	FCMSP701 Miniature Flow Control  Page F31	FCCSP731 Compact Flow Control  Page F31	
	In-Line Flow Control Valves	FC832 Flow Control  Page F32	FCB832 Bi-Directional Flow Control  Page F32	FCPM832 Panel Mountable Flow Control  Page F33	FC836 Threaded Flow Control  Page F33
Compact Metal Flow Control Valves		FC705 Push-to-Connect Metal Flow Control  Page F34	FC701 Push-to-Connect Metal Flow Control - BSPP  Page F34	FC708 Threaded Port Meter Out Flow Control  Page F34	FC702 Threaded Port Metal Flow Control - BSPP  Page F34
	Flow Control Check Valves	32PLCK In-Line Check Valve  Page F35	W68PLCK Male Check Valve  Page F35	W68PLCKI Male Check Valve Meter In  Page F35	68PLCK Male Check Valve Meter Out - BSPP  Page F36
VC Check Valve  Page F36					









Flow Controls & Check Valves

Misc Accessories

Integrated Fittings

Accessories



Blocking Flow Control Valves	FC601 Push-to-Connect Lock Out Valves  Page F37	FC601 Push-to-Connect Lock-Out Valve - BSPP  Page F37	FC602 Threaded Port Lock Out Valves  Page F37	FC608 Threaded Port Lock-Out Valve - BSPP  Page F37	
	Threshold Sensor	PSBJ731 Pneumatic - 5/32 Pilot  Page F38	PSBJ731 Pneumatic - 4mm Pilot  Page F38	PSPJ731 Pneumatic - 10-32 Pilot  Page F38	PSBJ708 Pneumatic - M5 Pilot  Page F38

Flow Controls
& Check Valves

Misc
Accessories

Integrated
Fittings

Accessories



Compact Flow Control Valves

Compact flow control regulators ensure excellent performance of flow and are perfectly suited for reduced spaces due to their small size. The sensitivity of the adjustment screw provides very precise air flow control and regulation. A locking nut guarantees stability of adjustment against vibration tampering of the flow setting.



Material Specifications

Body (depending upon the model)	Glass reinforced nylon 6.6 Brass
Gripping Ring	Stainless Steel
Adjustment Screws	Nickel-plated brass
Locking Nut	Nickel-plated brass
Base	Nickel-plated brass

Applicable Tube

Tube O.D.	1/8, 5/32, 1/4, 3/8
Tube O.D. (mm)	4, 6, 8, 10, 12

Operating information

Pressure range:	15 to 145 PSI
Temperature range:	30°F to 160°F
Working fluid:	Compressed air

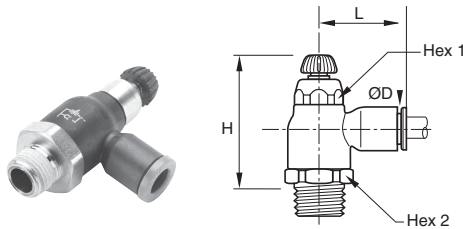

FCC731 Compact Meter Out - NPT

Tube size (In)	NPT	Hex 1 (In)	Hex 2 (In)	H Open	H Closed	L	Part number
5/32	1/8	0.63	0.39	1.67	1.44	0.85	FCC731-5/32-2
	1/4	0.63	0.39	1.67	1.44	0.85	FCC731-5/32-4
1/4	1/8	0.63	0.39	1.67	1.44	0.85	FCC731-4-2
	1/4	0.63	0.39	1.67	1.44	0.85	FCC731-4-4
3/8	1/4	0.91	0.67	2.03	1.71	1.22	FCC731-6-4
	3/8	0.91	0.67	2.03	1.71	1.22	FCC731-6-6

FC731 Compact Meter Out - BSPP

Tube size (mm)	BSPP	Hex 1 (mm)	Hex 2 (mm)	H Open	H Closed	L	Part number
4	1/8	10	16	38.0	44.0	22.0	FCC731-4M-2G
	1/8	10	16	38.0	44.0	22.0	FCC731-6M-2G
6	1/4	10	16	36.5	42.5	22.0	FCC731-6M-4G
	1/8	14	19	41.5	48.0	28.0	FCC731-8M-2G
8	1/4	14	19	41.5	48.0	28.0	FCC731-8M-4G
	3/8	14	19	41.5	48.0	28.0	FCC731-8M-6G
10	1/4	17	23	45.5	53.5	31.5	FCC731-10M-4G
	3/8	17	23	45.5	54.0	31.5	FCC731-10M-6G
12	3/8	17	23	45.5	54.0	35.0	FCC731-12M-6G
	1/2	17	24	45.5	54.0	35.0	FCC731-12M-8G

Most popular.

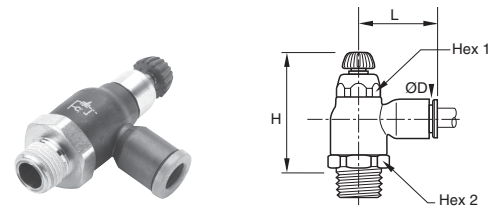

FCCB731 Compact Bi-Directional Flow Control - NPT

Tube size (In)	NPT	Hex 1 (In)	Hex 2 (In)	H Open	H Closed	L	Part number
5/32	1/8	0.63	0.39	1.67	1.44	0.85	FCCB731-5/32-2
	1/8	0.63	0.39	1.67	1.44	0.85	FCCB731-4-2
1/4	1/4	0.63	0.39	1.67	1.44	0.85	FCCB731-4-4

FCCB731 Compact Bi-Directional Flow Control - BSPP

Tube size (mm)	BSPP	Hex 1 (mm)	Hex 2 (mm)	H Open	H Closed	L	Part number
4	1/8	10	16	38.0	44.0	22.0	FCCB731-4M-2G
	1/8	10	16	38.0	44.0	22.0	FCCB731-6M-2G
6	1/4	10	16	36.5	42.5	22.0	FCCB731-6M-4G
	1/8	14	19	41.5	48.0	28.0	FCCB731-8M-2G
8	1/4	14	19	41.5	48.0	28.0	FCCB731-8M-4G
	3/8	14	19	41.5	48.0	28.0	FCCB731-8M-6G

Flow Controls & Check Valves

Misc Accessories

Integrated Fittings

Accessories



For inventory, lead time, and kit lookup, visit www.pdnplu.com

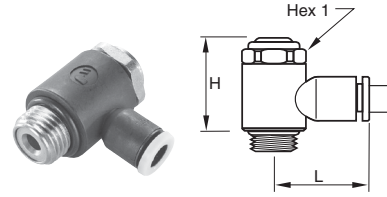
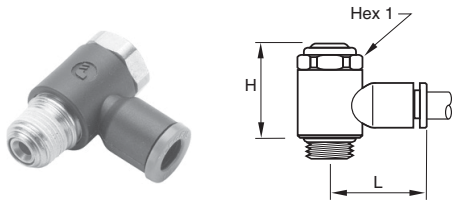

FCKC731 Knobless Meter Out Flow Control - NPT

Tube size (In)	NPT / UNF	Hex 1 (In)	H	L	Part number
1/8	10-32	10-32	-	0.69	FCKC731-2-0
	1/8	1/8	13	0.79	FCKC731-2-2
5/32	10-32	10-32	-	0.69	FCKC731-5/32-0
	1/8	1/8	13	0.79	FCKC731-5/32-2
1/4	10-32	10-32	-	0.69	FCKC731-4-0
	1/8	1/8	13	0.79	FCKC731-4-2
5/16	1/4	1/4	17	1.04	FCKC731-4-4
	1/8	1/8	13	0.79	FCKC731-5-2
3/8	1/4	1/4	17	1.04	FCKC731-5-4
	3/8	3/8	20	1.14	FCKC731-6-6

FCKCB731 Knobless Bi-Directional Flow Control - BSPP

Tube size (In)	BSPP / M5	Hex 1 (In)	H	L	Part number
4	M5X0.8	8	17.5	17.0	FCKCB731-4M-M5
	1/8	13	25.0	19.0	FCKCB731-4M-2G
6	M5X0.8	8	17.5	19.0	FCKCB731-6M-M5
	1/8	13	25.0	21.0	FCKCB731-6M-2G
8	1/4	17	26.5	22.0	FCKCB731-6M-4G
	1/8	13	25.0	26.0	FCKCB731-8M-2G
8	1/4	17	26.5	27.0	FCKCB731-8M-4G
	3/8	20	37.5	29.0	FCKCB731-8M-6G

FCKC731 Knobless Meter Out Flow Control - BSPP

Tube size (mm)	BSPP / M5	Hex 1 (mm)	H	L	Part number
4	M5X0.8	8.0	17.5	17.0	FCKC731-4M-M5
	1/8	13.0	25.0	19.0	FCKC731-4M-2G
6	M5X0.8	8.0	17.5	19.0	FCKC731-6M-M5
	1/8	13.0	25.0	21.0	FCKC731-6M-2G
8	1/4	17.0	26.5	22.0	FCKC731-6M-4G
	1/8	13.0	25.0	26.0	FCKC731-8M-2G
8	1/4	17.0	26.5	27.0	FCKC731-8M-4G
	3/8	20.0	37.5	29.0	FCKC731-8M-6G
10	1/4	17.0	26.5	29.0	FCKC731-10M-4G
	3/8	20.0	37.5	31.0	FCKC731-10M-6G
12	1/2	23.0	43.0	37.0	FCKC731-10M-8G
	3/8	20.0	37.5	6.8	FCKC731-12M-6G
	1/2	23.0	43.0	37.0	FCKC731-12M-8G

Flow Controls & Check Valves

Misc Accessories

Integrated Fittings

Accessories



For inventory, lead times, and kit lookup, visit www.pdnplu.com

Miniature Flow Control Valves

The miniature flow control regulator is especially adapted for all very small sized pneumatic applications (micro-pneumatic in particular). They are specifically designed for use with small bore cylinders (pancake / flat cylinders). Miniature flow control regulators are available in meter out, meter in and Bi-Directional versions.

Material Specifications

Body (depending upon the model)	Glass reinforced nylon 6.6 Brass
Gripping Ring	Stainless Steel
Adjustment Screws	Nickel-plated brass
Locking Nut	Nickel-plated brass
Base	Nickel-plated brass

Applicable Tube

Tube O.D.	1/8, 5/32, 1/4
Tube O.D. (mm)	3, 4, 6, 8

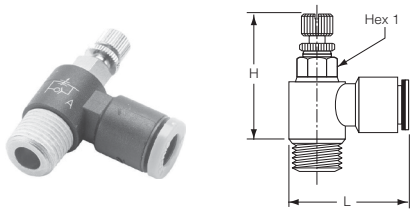

FCM731 Miniature Meter Out Flow Control - NPT

Tube size (in)	NPT	Hex 1 (mm)	H Open	H Closed	L	Part number
1/8	10-32	6	1.14	0.91	0.67	FCM731-2-0
	1/8	7	1.41	1.26	0.69	FCM731-2-2
5/32	10-32	6	1.02	0.93	0.67	FCM731-5/32-0
	1/8	7	1.16	1.06	0.71	FCM731-5/32-2
1/4	10-32	6	1.02	0.93	0.73	FCM731-4-0
	1/8	7	1.16	1.06	0.75	FCM731-4-2
	1/4	8	1.28	1.18	0.77	FCM731-4-4

FCM731 Miniature Meter Out Flow Control - BSPP

Tube size (mm)	BSPP	Hex 1 (mm)	H Closed	H Open	L	Part number
3	M3X0.5	6	23.5	26.0	17.0	FCM731-3M-M3
	M5X0.8	6	23.5	26.0	17.0	FCM731-3M-M5
4	M3X0.5	6	23.5	26.0	16.5	FCM731-4M-M3
	M5X0.8	6	23.5	26.0	17.0	FCM731-4M-M5
6	1/8	7	27.0	29.5	18.0	FCM731-4M-2G
	M5X0.8	6	23.5	26.0	18.0	FCM731-6M-M5
8	1/8	7	27.0	29.5	18.5	FCM731-6M-2G
	1/4	8	30.0	32.5	19.0	FCM731-6M-4G
8	1/8	13	26.5	31.0	26.0	FCM731-8M-2G
	1/4	16	29.0	34.0	27.5	FCM731-8M-4G
	3/8	20	36.0	42.0	29.0	FCM731-8M-6G

Most popular.



Operating information

Pressure range:	15 to 145 PSI
Temperature range:	30°F to 160°F
Working fluid:	Compressed air

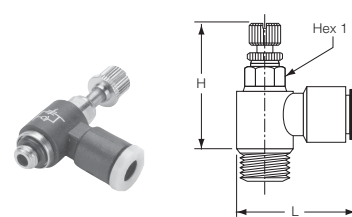

FCMB731 Miniature Bi-Directional Flow Control - BSPP

Tube size (mm)	BSPP	Hex 1	H Open	H Closed	L	Part number
4	M5X0.8	6	23.5	26.0	16.5	FCMB731-4M-M5
	1/8	7	27.0	29.5	17.0	FCMB731-4M-2G
6	M5X0.8	6	23.5	26.0	18.0	FCMB731-6M-M5
	1/8	7	27.0	29.5	18.0	FCMB731-6M-2G
6	1/4	8	30.0	32.5	18.5	FCMB731-6M-4G

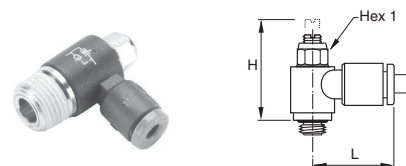

FCMB731 Miniature Bi-Directional Flow Control - BSPP

Tube size (in)	NPT	Hex 1 mm	H Open	H Closed	L	Part number
1/8	10-32	6	0.79	0.65	0.65	FCMK731-2-0
	1/8	6	0.85	0.71	0.71	FCMK731-2-2
5/32	10-32	6	0.79	0.65	0.65	FCMK731-5/32-0
	1/8	6	0.85	0.71	0.71	FCMK731-5/32-2
1/4	10-32	6	0.79	0.65	0.65	FCMK731-4-0
	1/8	6	0.85	0.71	0.73	FCMK731-4-2
	1/4	6	0.97	0.83	0.73	FCMK731-4-4

Flow Controls & Check Valves

Misc Accessories

Integrated Fittings

Accessories



Swivel Outlet Flow Control Valves

Flow control regulators with “swivel outlet” are especially designed to allow a vertical or angled tube exit where access is restricted. The swivel outlet comes with instant push-in connection to ease installation. Flow control regulators with swivel outlet are available in meter out and meter in versions.



Material Specifications

Body	Glass reinforced nylon 6.6
Gripping Ring	Stainless Steel
Adjustment Screws	Nickel-plated brass
Locking Nut	Nickel-plated brass
Base	Nickel-plated brass

Applicable Tube

Tube O.D.	5/32, 1/4, 3/8
Tube O.D. (mm)	4, 6, 8, 10, 12

Operating information

Pressure range:	15 to 145 PSI
Temperature range:	30°F to 160°F
Working fluid:	Compressed air

Flow Controls
& Check Valves

Misc
Accessories

Integrated
Fittings

Accessories

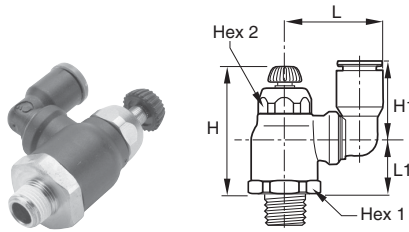

FCCS731 Compact Swivel Outlet Flow Control

Tube size (In)	NPT	Hex 1 mm	Hex 2 mm	H Closed	H Open	H1	L	L1	Part number
1/4	1/8	19	10	1.87	2.09	0.63	0.93	0.65	FCCS731-4-2
	1/4	19	14	1.79	1.99	0.73	1.00	0.89	FCCS731-4-4
3/8	1/4	23	17	1.93	2.20	1.04	1.34	0.97	FCCS731-6-4
	3/8	23	17	1.93	2.20	1.04	1.34	0.97	FCCS731-6-6

FCCS731 Compact Swivel Outlet - BSPP

Tube size (In)	BSPP	Hex 1 mm	Hex 2 mm	H Closed	H Open	H1	L	L1	Part number
6	1/8	16	10	38.0	44.0	16.0	23.5	18.0	FCCS731-6M-2G
	1/4	16	10	36.5	42.5	16.0	23.5	16.5	FCCS731-6M-4G
8	1/8	19	14	41.5	48.0	23.0	28.0	19.0	FCCS731-8M-2G
	1/4	19	14	41.5	48.0	23.0	28.0	19.5	FCCS731-8M-4G
10	3/8	19	14	41.5	48.0	23.0	28.0	17.5	FCCS731-8M-6G
	1/4	23	17	45.5	53.5	26.5	35.0	21.0	FCCS731-10M-4G
	3/8	23	17	45.5	54.0	26.5	35.0	21.5	FCCS731-10M-6G
12	3/8	23	17	45.5	54.0	31.0	38.0	21.5	FCCS731-12M-6G
	1/2	23	17	45.5	54.0	31.0	38.0	21.0	FCCS731-12M-8G

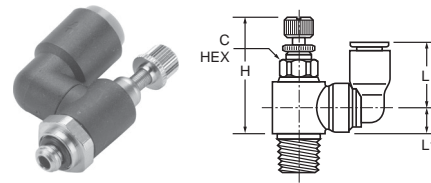

FCMS731 Mini Swivel Outlet Flow Control

Tube size (In)	NPT	Hex 1 mm	H Closed	H Open	H1	L	L1	Part number
5/32	10-32	6	0.96	1.08	0.55	0.73	0.26	FCMS731-5/32-0
	1/8	8	1.08	1.20	0.55	0.73	0.33	FCMS731-5/32-2

FCMS731 Miniature Swivel Outlet - BSPP

Tube size (In)	BSPP	Hex 1 mm	H Closed	H Open	H1	L	L1	Part number
4	M5X0.8	6	24.5	27.5	14.5	19.5	6.5	FCMS731-4M-M5
	1/8	7	27.5	31.0	14.5	20.0	8.5	FCMS731-4M-2G
6	M5X0.8	6	24.5	27.5	16.0	21.5	6.5	FCMS731-6M-M5
6	1/8	7	27.5	31.0	16.0	22.0	8.5	FCMS731-6M-2G



Plug-In Flow Control Valves

Plug-in flow control regulators can be directly mounted into existing fittings and allow very compact installations. They are particularly suited for mounting in manifolds using cartridges. Their design and function give equal performance to that of flow control regulators with threaded connections.

Material Specifications

Body	Glass reinforced nylon 6.6
Gripping Ring	Stainless Steel
Adjustment Screws	Nickel-plated brass
Locking Nut	Nickel-plated brass
Tailpiece	Nickel-plated brass

Applicable Tube

Tube O.D.	1/8, 5/32, 1/4
Tube O.D. (mm)	4, 6, 8, 10, 12



Operating information

Pressure range:	15 to 145 PSI
Temperature range:	30°F to 160°F
Working fluid:	Compressed air

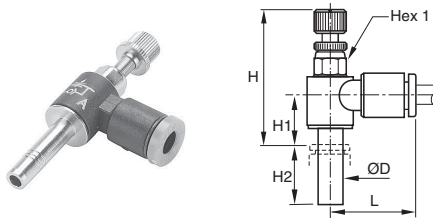

FCMS731 Plug-In Mini Flow Control

Tube size (In)	Hex 1 mm	H Open	H Closed	H1	H2	L	Part number
1/8	6	1.04	0.94	0.12	0.59	0.67	FCMS731-2
5/32	6	1.10	1.00	0.37	0.61	0.67	FCMS731-5/32
1/4	7	1.18	1.08	0.12	0.73	0.73	FCMS731-4

FCMS701 - Plug-In Miniature Flow Control

Tube size (mm)	Hex 1 mm	H Closed	H Open	H1	H2	L	Part number
4	6	25.5	28.0	9.5	15.5	17.0	FCMS701-4M
6	7	27.5	29.0	10.5	17.0	18.5	FCMS701-6M

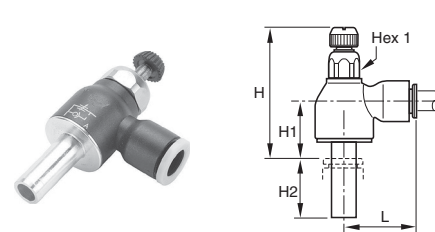

FCCSP731 Plug-In Compact Flow Control

Tube size (mm)	Hex 1 mm	H Closed	H Open	H1	H2	L	Part number
6	10	35.0	41.0	14.0	17.0	22.0	FCCSP731-6M
8	14	39.5	46.5	16.0	21.5	28.0	FCCSP731-8M
10	17	43.5	51.5	17.5	24.5	31.5	FCCSP731-10M
12	17	43.0	51.0	17.0	27.0	31.5	FCCSP731-12M

Flow Controls
& Check Valves

Misc
Accessories

Integrated
Fittings

Accessories



In-Line Flow Control Valves

In-line flow controls are unidirectional flow control valves. Intake air flows freely through the flow control; exhaust air is metered out through a specially designed adjustment screw. An arrow on the body of the valve indicates the direction of controlled flow. They can be easily added to existing circuitry. Simply splice it into the cylinder port line.

They can be used individually or they may be stacked together using two joining clips.

Material Specifications

Body	Glass reinforced nylon 6.6
Gripping Ring	Stainless Steel
Adjustment Screws	Nickel-plated brass
Locking Nut	Nickel-plated brass
Tailpiece	Nickel-plated brass

Applicable Tube

Tube O.D.	5/32, 1/4, 5/16, 3/8, 1/2
Tube O.D. (mm)	4, 6, 8, 10, 12

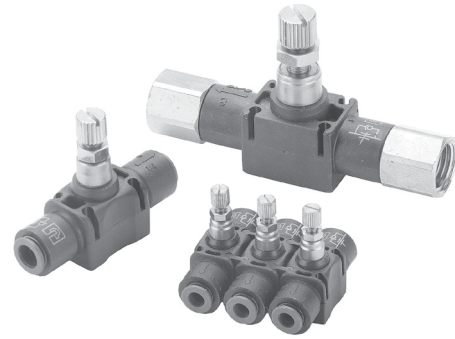

Operating information

Pressure range:	15 to 145 PSI
Temperature range:	30°F to 160°F
Working fluid:	Compressed air

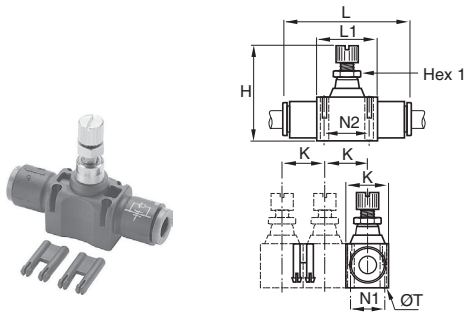

FC832 In-Line Flow Control

Tube size (In)	Hex 1 mm	H Closed	H Open	K	L	L1	N1	N2	T	Part number
5/32	5	1.15	1.31	0.47	1.52	0.59	0.31	0.43	0.09	FC832-5/32
1/4	8	1.54	1.74	0.66	2.00	0.90	0.43	0.66	0.12	FC832-4
5/16	11	1.73	1.97	0.73	2.38	1.02	0.49	0.79	0.13	FC832-5
3/8	14	2.03	2.38	0.94	2.87	1.29	0.62	1.01	1.60	FC832-6
1/2	14	2.24	2.63	1.09	3.35	1.37	0.78	1.07	0.16	FC832-8

FC832 In-Line Flow Control

Tube size (mm)	Hex 1 mm	H Closed	H Open	K	L	L1	N1	N2	T	Part number
4	5	29.5	33.5	12.0	39.0	15.0	8.0	11.0	2.2	FC832-4M
6	8	39.5	44.5	17.0	54.0	23.0	11.0	17.0	3.2	FC832-6M
8	11	44.0	50.0	18.5	60.5	26.0	12.5	20.0	3.2	FC832-8M
10	14	52.0	61.0	24.0	76.0	33.0	16.0	26.0	4.2	FC832-10M
12	14	57.5	67.5	28.0	86.0	35.0	20.0	27.5	4.2	FC832-12M

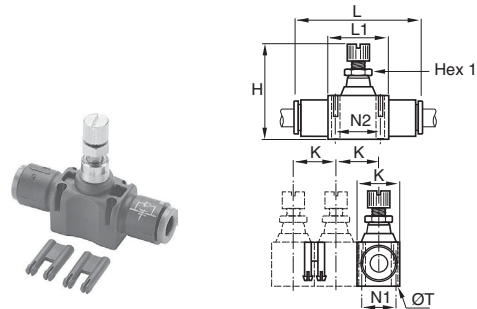

FCB832 In-Line Bi-Directional Flow Control

Tube size (In)	Hex 1 mm	H Closed	H Open	K	L	L1	N1	N2	T	Part number
5/32	5	1.15	1.31	0.47	1.52	0.59	0.31	0.43	0.09	FCB832-5/32
1/4	8	1.54	1.74	0.66	2.00	0.90	0.43	0.66	0.12	FCB832-4
5/16	11	1.73	1.97	0.73	2.38	1.02	0.49	0.79	0.13	FCB832-5

FCB832 In-Line Bi-Directional Flow Control

Tube size (mm)	Hex 1 mm	H Closed	H Open	K	L	L1	N1	N2	T	Part number
4	5	29.5	33.5	12.0	39.0	15.0	8.0	11.0	2.2	FCB832-4M
6	8	39.5	44.5	17.0	54.0	23.0	11.0	17.0	3.2	FCB832-6M
8	11	44.0	50.0	18.5	60.5	26.0	12.5	20.0	3.2	FCB832-8M

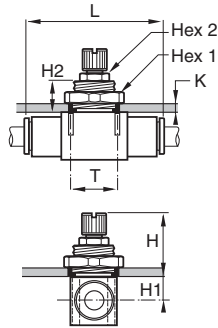

FCPM832 In-Line Panel Mountable Flow Control

Tube size (mm)	Hex 1 mm	Hex 2 mm	H Closed mm	H Open mm	K mm	L mm	H1 mm	H2 mm	T mm	Part number
4	14		21.5	25.5	6.0	39.0	6.5	11.0	10.5	FCPM832-4M
6	19		27.5	32.5	7.0	54.0	7.5	13.5	16.5	FCPM832-6M
8	24	11	28.5	34.5	7.0	60.5	9.0	13.5	18.5	FCPM832-8M
10	30	14	29.5	38.5	7.0	76.0	11.5	13.5	24.5	FCPM832-10M
12	32	14	32.0	42.0	8.0	86.0	12.5	15.5	27.5	FCPM832-12M

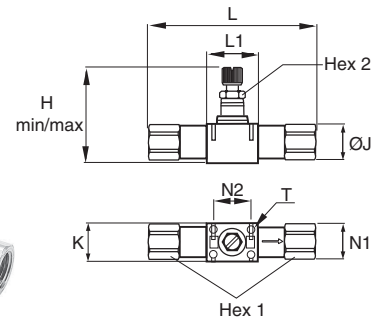
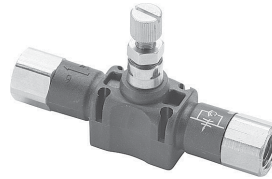

FC836 Threaded In-Line Flow Control

NPT	Hex 1 mm	Hex 2 mm	H Closed mm	H Open mm	K mm	L mm	L1 mm	N1 mm	N2 mm	T mm	Part number
1/8	13	8.00	1.56	1.75	0.67	2.70	0.91	0.43	0.67	0.12	FC836-2
1/4	16	11.00	1.73	1.97	0.73	3.27	1.02	0.49	0.79	0.12	FC836-4
3/8	22	14.00	2.05	2.40	0.94	3.82	1.30	0.63	1.02	0.16	FC836-6
1/2	24	14.00	2.26	2.66	1.10	4.76	1.38	0.79	1.08	0.16	FC836-8

FC836 Threaded In-Line Flow Control - BSPP

BSPP	Hex 1 mm	Hex 2 mm	H Closed mm	H Open mm	K mm	L mm	L1 mm	N1 mm	N2 mm	T mm	Part number
1/8	13	8	39.5	44.5	17.0	68.5	23.1	11.0	17.0	3.2	FC836-2G
1/4	16	11	44.0	50.0	18.5	83.0	25.9	12.5	20.0	3.2	FC836-4G
3/8	19	14	52.0	61.0	24.0	97.0	33.0	16.0	26.0	4.2	FC836-6G
1/2	24	14	57.5	67.5	28.0	121.0	35.0	20.0	27.5	4.2	FC836-8G

Flow Controls & Check Valves

Misc Accessories

Integrated Fittings

Accessories



Compact Metal Flow Control Valves

Metal flow control regulators are suited for use in severe conditions (temperatures, sparks, abrasion, etc). The screw and locking nut have been designed for easy manipulation, by hand. Adjustment can be made with a screwdriver and locking by use of a wrench.



Material Specifications

Body	Treated brass
Gripping Ring	Stainless Steel
Adjustment Screws	Nickel-plated brass
Locking Nut	Nickel-plated brass
Tailpiece	Nickel-plated brass

Applicable Tube

Tube O.D.	1/8, 5/32, 1/4, 3/8
Tube O.D. (mm)	4, 6, 8, 10, 12, 14

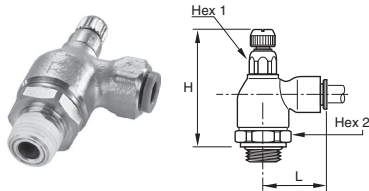

FC705 Push-to-Connect Metal Flow Control

Tube size (In)	NPT	Hex 1 mm	Hex 2 mm	H Closed	H Open	L	Part number
5/32	1/8	19	10	1.79	2.01	0.85	FC705-5/32-2
1/4	1/8	19	10	1.79	2.01	0.97	FC705-4-2
	1/4	19	10	1.79	2.01	0.97	FC705-4-4
3/8	1/4	19	14	1.91	2.11	1.14	FC705-6-4
	3/8	25	17	2.15	2.40	1.40	FC705-6-6

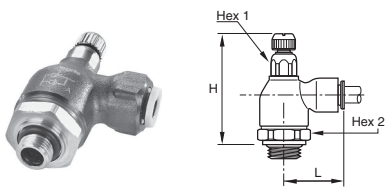

FC701 Push-to-Connect Metal Flow Control - BSPP

Tube size (mm)	BSPP	Hex 1 mm	Hex 2 mm	H Closed	H Open	L	Part number
4	1/8	10	19	47.0	53.0	21.0	FC701-4M-2G
	1/8	10	19	47.0	53.0	24.5	FC701-6M-2G
6	1/4	10	19	47.5	53.0	24.5	FC701-6M-4G
	1/8	14	19	50.0	55.0	29.0	FC701-8M-2G
8	1/4	14	19	50.0	56.0	29.0	FC701-8M-4G
	3/8	17	25	56.0	62.0	30.5	FC701-8M-6G
10	1/4	14	19	50.0	56.0	35.0	FC701-10M-4G
	3/8	17	25	56.0	62.0	35.0	FC701-10M-6G
12	3/8	17	25	56.0	62.0	38.0	FC701-12M-6G
	1/2	17	25	55.0	62.0	38.0	FC701-12M-8G
14	1/2	17	25	55.0	62.0	41.0	FC701-14M-8G

Operating information

Pressure range:	15 to 145 PSI
Temperature range:	30°F to 160°F
Working fluid:	Compressed air

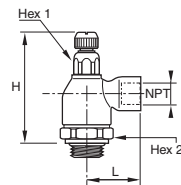

FC708 Threaded Port Meter Out Flow Control

NPT	Hex 1 mm	Hex 2 mm	H Closed	H Open	L	L1	L2	Part number
1/8	19	10	1.79	2.01	0.89	0.87	1.14	FC708-2
1/4	19	14	1.91	2.11	1.28	0.87	1.28	FC708-4
3/8	25	17	2.15	2.40	1.36	0.91	1.44	FC708-6
1/2	25	17	2.15	2.40	1.50	0.91	1.50	FC708-8

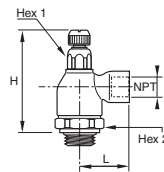

FC702 Threaded Port Meter Out Flow Control - BSPP

BSPP	Hex 1 mm	Hex 2 mm	H Closed	H Open	L	Part number
1/8	10	19	47.0	52.5	22.5	FC702-2G
1/4	14	19	50.5	55.5	32.0	FC702-4G
3/8	17	25	56.0	62.0	34.5	FC702-6G
1/2	17	25	55.0	62.0	37.5	FC702-8G

Flow Control Check Valves

These in-line check valves allows air to pass in one direction while blocking flow in the other direction. Their extreme compactness and light weight make them suitable as a safety item in compressed air circuits. The body of the fitting contains an arrow to indicate the direction of flow.

Material Specifications

Body	32PLCK: Nylon/nickel plated brass
	68PLCK: Nylon body with nickel-plated brass base
	VC: Acetal
Gripping Ring	Stainless Steel
O-ring	Nitrile (32PLCK & 68PLCK)
	EPDM (VC)

Applicable Tube

Tube O.D.	PLCK: 5/32, 1/4, 5/16, 3/8 VC: 1/4, 5/16, 3/8
Tube O.D. (mm)	PLCK: 4, 6, 8, 10, 12



Operating information

Pressure range:	15 to 145 PSI
Temperature range:	34°F to 150°F
Cracking pressure:	PLCK: 7 PSI
	VC: 1/3 PSI
Working fluid:	Compressed air

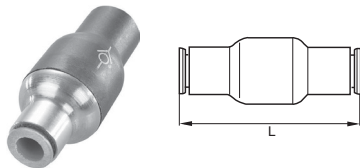

32PLCK In-Line Check Valve - NPT

Tube size (In)	L	Part number
5/32	1.52	32PLCK-5/32
1/4	1.61	32PLCK-4
5/16	2.03	32PLCK-5
3/8	2.50	32PLCK-6

32PLCK In-Line Check Valve - BSPP

Tube size (mm)	L	Part number
4	38.5	32PLCK-4M
6	41.0	32PLCK-6M
8	51.5	32PLCK-8M
10	63.5	32PLCK-10M
12	66.5	32PLCK-12M

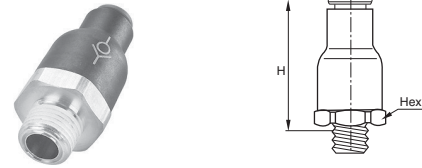

W68PLCK Male Check Valve

Tube size (In)	NPT/ UNF	Hex mm	H	Part number
5/32	10-32	9	1.26	68PLCK-5/32-0
5/32	1/8	16	1.12	W68PLCK-5/32-2
1/4	1/8	19	1.42	W68PLCK-4-2
1/4	1/4	19	1.42	W68PLCK-4-4
3/8	1/4	23	1.65	W68PLCK-6-4
3/8	3/8	23	1.65	W68PLCK-6-6

W68PLCKI Male Check Valve Meter In

Tube size (in)	NPT/ UNF	Hex mm	H	Part number
5/32	10-32	9	1.26	68PLCKI-5/32-0
5/32	1/8	16	1.12	W68PLCKI-5/32-2
1/4	1/8	19	1.42	W68PLCKI-4-2
1/4	1/4	19	1.42	W68PLCKI-4-4
3/8	1/4	23	1.65	W68PLCKI-6-4
3/8	3/8	23	1.65	W68PLCKI-6-6

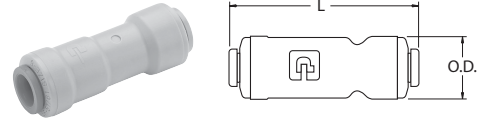
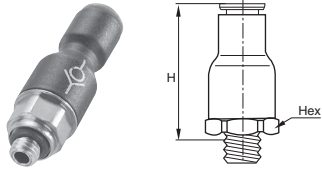

68PLCK Male Check Valve Meter Out - BSPP

Tube size (mm)	BSPP	Hex 1 mm	H	Part number
4	M5X0.8	9	32.0	68PLCK-4M-M5
4	1/8	16	28.5	68PLCK-4M-2G
6	1/8	16	30.5	68PLCK-6M-2G
6	1/4	16	30.5	68PLCK-6M-4G
8	1/8	19	36.0	68PLCK-8M-2G
8	1/4	19	36.0	68PLCK-8M-4G

VC - Check Valve

Tube size (in)	BSPP	Hex 1 mm	Part number
1/4	2.00	.66	A4VC4-MG
5/16	2.10	.70	A5VC5-MG
3/8	2.15	.80	A6VC6-MG

68PLCKI Male Check Valve Meter In - BSPP

Tube size (mm)	BSPP	Hex 1 mm	H	Part number
4	M5X0.8	9	32.0	68PLCKI-4M-M5
6	1/8	16	30.5	68PLCKI-6M-2G
8	1/8	19	36.0	68PLCKI-8M-2G
8	1/4	19	36.0	68PLCKI-8M-4G
10	3/8	23	42.0	68PLCKI-10M-6G
12	3/8	23	42.0	68PLCKI-12M-6G
12	1/2	23	44.0	68PLCKI-12M-8G

Flow Controls
 & Check Valves

Misc
 Accessories

Integrated
 Fittings

Accessories



Blocking Flow Control Valves

Blocking valves prevents damage to work and equipment in the event of a loss of pressure. Blocking valves which are mounted in pairs on a cylinder lock the piston by simultaneously cutting off the supply and exhaust. Functional locks are more precise and rapid when blocking valves are located on the cylinder: the volume of air in the pipe work no longer needs to be taken into consideration.



Material Specifications

Body	Treated brass
Gripping Ring	Stainless Steel
Seals, Diaphragm	Nitrile

Applicable Tube

Tube O.D.	1/8, 5/32, 1/4, 3/8
Tube O.D. (mm)	4, 6, 8, 10, 12, 14

Operating information

Pressure range:	15 to 145 PSI
Temperature range:	-4°F to 160°F
Number of cycles:	> 10 million at 68°F and 1 Hz
Leak rate:	< 3.2 CCM
Working fluid:	Compressed air

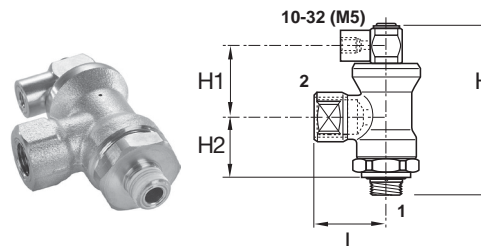
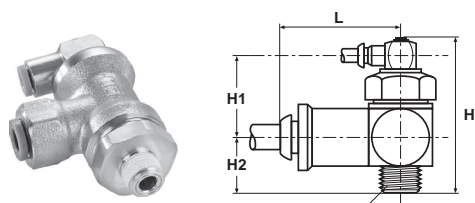

FC601 Push-to-Connect Lockout Valves

Tube size (In)	NPT	Hex mm	H	H1	H2	L	Part number
1/4	1/8	21	2.03	1.24	0.79	1.10	FC601-4-2
1/4	1/4	21	2.03	1.24	0.79	1.10	FC601-4-4
3/8	3/8	24	2.19	1.14	1.04	1.38	FC601-6-6
1/2	1/2	24	2.19	1.14	1.04	1.69	FC601-8-8

FC601 Push-to-Connect Lockout Valve - BSPP

Tube size (mm)	BSPP	Hex 1 mm	H	H1	H2	L	Part number
6	1/8	21	53	24.5	21.0	28.0	FC601-6M-2G
6	1/4	21	53	24.5	21.0	28.0	FC601-6M-4G
8	1/4	21	53	24.5	21.0	28.0	FC601-8M-4G
8	3/8	24	56	25.0	23.0	34.5	FC601-8M-6G
10	3/8	24	56	25.0	23.0	35.0	FC601-10M-6G
12	1/2	24	56	25.0	23.0	37.5	FC601-12M-8G

FC602 Threaded Port Lockout Valves

1 NPT	2 NPT	Hex mm	H	H1	H2	L	Part number
1/4	1/8	21	2.03	1.24	0.79	1.04	FC602-2
1/4	1/4	21	2.03	1.24	0.79	1.04	FC602-4
3/8	3/8	24	2.19	1.14	1.04	1.34	FC602-6
1/2	1/2	24	2.19	1.14	1.04	1.57	FC602-8

FC608 Threaded Port Lockout Valve - BSPP

1 BSPP	2 BSPP	Hex 1 mm	H	H1	H2	L	Part number
1/8	1/4	21	53	24.5	21.0	28.0	FC608-4G-2G
1/4	1/4	21	53	24.5	21.0	28.0	FC608-4G-4G
3/8	3/8	24	56	25.0	23.0	34.0	FC608-6G-6G
1/2	1/2	24	56	25.0	23.0	41.0	FC608-8G-8G

Flow Controls & Check Valves

Misc Accessories

Integrated Fittings

Accessories



Threshold Sensor

The sensor fitting detects the absence of pressure and translates it to a high pressure pneumatic output. When used to monitor the decaying or exhausting side of a pneumatic cylinder's piston, it emits a positive output. When the cylinder comes to the end of its stroke, wherever that may be, the signal emitted from the sensor can then be used to pilot the next step.

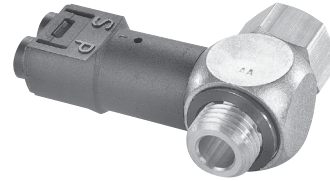

Operating information

	PSBJ, PSPJ	PSPE
Working pressure:	45 to 115 PSI	45 to 115 PSI
Breaking pressure:	8.5 PSI	7 PSI
Working temperature:	5°F to 140°F	–
Response time:	3 Ms	–
Current rating:	–	5A / 250VAC 5W / 48VDC
Reset pressure:	10 PSI	10 PSI
UL listed component		

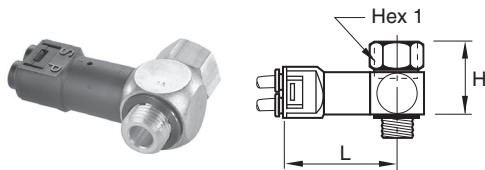

PSBJ731 Pneumatic Threshold Sensor - 5/32 Pilot

NPT / UNF	Hex 1 mm	H	L	Part number
10-32	5/16	0.62	1.70	PSBJ731-0
1/8	9/16	0.90	1.74	PSBJ731-2
1/4	5/8	1.09	1.81	PSBJ731-4
3/8	7/8	1.13	1.91	PSBJ731-6
1/2	1	1.17	2.05	PSBJ731-8

PSBJ731 Pneumatic Threshold Sensor - 4mm Pilot

BSPP	Hex 1 mm	H	L	Part number
M5X0.8	8	16	43.5	PSBJ731-M5
1/8	14	23	44.5	PSBJ731-2G
1/4	17	28	46.5	PSBJ731-4G
3/8	22	29	49.0	PSBJ731-6G
1/2	27	30	52.5	PSBJ731-8G

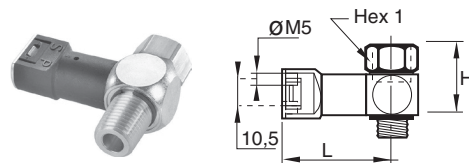

PSPJ731 Pneumatic Threshold Sensor - 10-32 Pilot

NPT	Hex 1 mm	H	L	Part number
1/8	9/16	0.90	1.58	PSPJ731-2
1/4	5/8	1.09	1.66	PSPJ731-4
3/8	7/8	1.13	1.76	PSPJ731-6

PSBJ708 Pneumatic Threshold Sensor - M5 Pilot

BSPP	Hex 1 mm	H	L	Part number
1/8	14	23	40.5	PSBJ708-2G
1/4	17	28	42.5	PSBJ708-4G

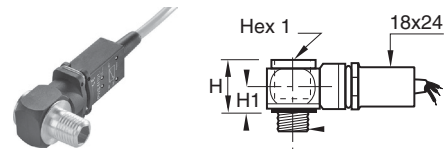

PSPE701 Pneumatic / Electric Threshold Sensor - BSPP

NPT	Hex 1 mm	H	H1	L	Part number
M5X0.8	8	20	10	49	PSPE701-M5
1/8	6	20	10	52	PSPE701-2G
1/4	8	20	10	54	PSPE701-4G
3/8	10	22	12	57	PSPE701-6G
1/2	12	26	14	58	PSPE701-8G

**Fax Forms, Part Number Index,
Safety Guide, Offer of Sale**

Part Number Index	G2-G26
Safety Guide	G27-G28
Offer of Sale	G29



For inventory, lead time, and kit lookup, visit www.pdnplu.com

Model No.	Section / Page No.	Model No.	Section / Page No.	Model No.	Section / Page No.	Model No.	Section / Page No.
003371000.....	F2, F3	032513838.....	F6	0R75VB.....	F14	169PMTNS-4-2.....	C30, E20
003371001.....	F2, F3	033400105.....	F14	0RB12B.....	F14	169PMTNS-4-4.....	C30, E20
003371002.....	F2, F3	033400319.....	F14	0RB12NB.....	F14	169PMTNS-4-6.....	C30, E20
003371003.....	F2, F3	033400504.....	F14	0RB12NVB.....	F14	169PMTNS-6-2.....	C30, E20
003371004.....	F2, F3	033408000.....	F14	0RB12VB.....	F14	169PMTNS-6-4.....	C30, E20
003378000.....	F2, F3	034750109.....	F14	0RB25B.....	F14	169PMTNS-6-6.....	C30, E20
003378001.....	F2, F3	034750120.....	F14	0RB25NB.....	F14	169PMTNS-6-8.....	C30, E20
003378002.....	F2, F3	034759000.....	F14	0RB25NFB.....	F14	169PMTNS-8-4.....	C30, E20
003378003.....	F2, F3	036408000.....	F14	0RB25VB.....	F14	169PMTNS-8-6.....	C30, E20
003378004.....	F2, F3	036508000.....	F14	0RB37B.....	F14	169PMTNS-8-8.....	C30, E20
003393000.....	F7	045020002.....	F8	0RB37FB.....	F14	171PMT-4-2.....	C30, E20
003393001.....	F7	045040004.....	F8	0RB37TB.....	F14	171PMT-4-4.....	C30, E20
003393002.....	F7	045060060.....	F8	0RB37VB.....	F14	171PMT-4-6.....	C30, E20
003393003.....	F7	045080080.....	F8	0RB50B.....	F14	171PMT-6-4.....	C30, E20
003393004.....	F7	045120012.....	F8	0RB50VB.....	F14	171PMT-6-6.....	C30, E20
00339G3000.....	F7	045160016.....	F8	0RB75B.....	F14	171PMT-8-4.....	C30, E20
00339G3001.....	F7	047020002.....	F9	0RB75FB.....	F14	171PMT-8-6.....	C30, E20
004700010.....	F23	047040004.....	F9	0RB75VB.....	F14	171PMT-8-8.....	C30, E20
004700900.....	F23	047060006.....	F9	1155H30.....	E56	171PMTNS-4-4.....	C30, E20
004707020.....	F24	047080008.....	F9	169PMNS-2-2.....	C29, E19	171PMTNS-4-6-4.....	C30, E20
004750010.....	F23	047120012.....	F9	169PMNS-3-2.....	C29, E19	171PMTNS-6-4.....	C30, E20
004750900.....	F23	047160016.....	F9	169PMNS-3-4.....	C29, E19	171PMTNS-6-4-4.....	C30, E20
006450060.....	F22	047200020.....	F9	169PMNS-5/32-2.....	C29, E19	171PMTNS-6-4-6.....	C30, E20
008230109.....	E65	047240024.....	F9	169PMT-10-6.....	C29, E19	171PMTNS-6-6.....	C30, E20
008230299.....	E65, E66, E67	067390000.....	F22, F24	169PMT-10-8.....	C29, E19	171PMTNS-6-8.....	C30, E20
008240109.....	E65, E66, E67	091660060.....	F22	169PMT-4-2.....	C29, E19	171PMTNS-8-4.....	C30, E20
032130599.....	E65, E66, E67, E68	0R12B.....	F14	169PMT-4-4.....	C29, E19	172PMT-4-2.....	C30, E20
032130899.....	E65, E66, E67	0R12NB.....	F14	169PMT-4-6.....	C29, E19	172PMT-4-4.....	C30, E20
032140299.....	E65	0R12NVB.....	F14	169PMT-6-2.....	C29, E19	172PMT-6-2.....	C30, E20
032500119.....	F4	0R12VB.....	F14	169PMT-6-4.....	C29, E19	172PMT-6-4.....	C30, E20
032500219.....	F4	0R25B.....	F14	169PMT-6-6.....	C29, E19	172PMT-6-6.....	C30, E20
032500319.....	F4	0R25NB.....	F14	169PMT-6-8.....	C29, E19	172PMT-8-4.....	C30, E20
032500419.....	F4	0R25NFB.....	F14	169PMT-8-4.....	C29, E19	172PMT-8-6.....	C30, E20
032500519.....	F4	0R25PB.....	F14	169PMT-8-6.....	C29, E19	172PMT-8-8.....	C30, E20
032510125.....	F6	0R25VB.....	F14	169PMT-8-8.....	C29, E19	172PMTNS-4-2.....	C30, E20
032510250.....	F6	0R37B.....	F14	169PMTL-10-8.....	C29, E19	172PMTNS-6-4.....	C30, E20
032510375.....	F6	0R37FB.....	F14	169PMTL-6-4.....	C29, E19	172PMTNS-6-4-4.....	C30, E20
032510500.....	F6	0R37TB.....	F14	169PMTL-6-6.....	C29, E19	172PMTNS-6-6.....	C30, E20
032511215.....	F6	0R37VB.....	F14	169PMTL-6-8.....	C29, E19	172PMTNS-6-8.....	C30, E20
032511225.....	F6	0R50B.....	F14	169PMTL-8-8.....	C29, E19	172PMTNS-8-6.....	C30, E20
032512525.....	F6	0R50VB.....	F14	169PMTNS-10-6.....	C30, E20	172PMTNS-8-6-8.....	C30, E20
032512538.....	F6	0R75B.....	F14	169PMTNS-10-8.....	C30, E20	172PMTNS-8-8.....	C30, E20
		0R75FB.....	F14	169PMTNS-12-8.....	C30, E20	207P-2.....	C54

Part Number Index
Safety Guide
Offer of Sale
Part Number Index, Safety Guide, Offer of Sale



For inventory, lead times, and kit lookup, visit www.pdnplu.com

Model No.	Section / Page No.	Model No.	Section / Page No.	Model No.	Section / Page No.	Model No.	Section / Page No.
2201P-2-2.....	C54	414211000.....	E4	520711000.....	E5	68PLCKI-12M-8G	F36
2220P-2-2.....	C54	414221000.....	E4	520718001.....	E7	68PLCKI-4M-M5	F36
3250G1000.....	F5	414251000.....	E4	520751000.....	E5	68PLCKI-5/32-0.....	F35
3250G1250.....	F5	414311000.....	E5	520811000.....	E4	68PLCKI-6M-2G	F36
3250G1500.....	F5	414321000.....	E5	520831000.....	E4	68PLCKI-8M-2G	F36
32PLCK-10M.....	F35	414351000.....	E5	520838004.....	E7	68PLCKI-8M-4G	F36
32PLCK-12M.....	F35	414411000.....	E3	520931000.....	E5	68PM-2-1.....	C29, E19
32PLCK-4.....	F35	414421000.....	E3	520A11000.....	E4	68PM-2-2.....	C29, E19
32PLCK-4M.....	F35	414451000.....	E3	520A51000.....	E4	68PM-3-1.....	C29, E19
32PLCK-5.....	F35	414711000.....	E5	521811000.....	E4	68PM-3-2.....	C29, E19
32PLCK-5/32.....	F35	414721000.....	E5	521831000.....	E4	68PM-3-4.....	C29, E19
32PLCK-6.....	F35	414751000.....	E5	522811000.....	E4	68PM-5/32-1	C29, E19
32PLCK-6M.....	F35	414811000.....	E3	522831000.....	E4	68PM-5/32-2	C29, E19
32PLCK-8M.....	F35	414821000.....	E3	523831000.....	E4	68PM-5/32-4	C29, E19
404111000.....	E5	414931000.....	E3	524211000.....	E4	68PMT-10-6.....	C29, E19
404118000.....	E7	414941000.....	E3	524251000.....	E4	68PMT-10-8.....	C29, E19
404211000.....	E4	414951000.....	E3	524411000.....	E3	68PMT-12-8.....	C29, E19
404311000.....	E5	422CR011K.....	E21	524431000.....	E3	68PMT-4-2.....	C29, E19
404411000.....	E3	422CR011W.....	E21	524451000.....	E3	68PMT-4-4.....	C29, E19
404711000.....	E5	422CR013W.....	E21	524711000.....	E5	68PMT-4-6.....	C29, E19
404811000.....	E3	422CR014W.....	E21	524751000.....	E5	68PMT-6-2.....	C29, E19
410008000.....	E7	422CR021K.....	E21	524811000.....	E4	68PMT-6-4.....	C29, E19
410008005.....	E7	422CR021W.....	E21	524831000.....	E4	68PMT-6-6.....	C29, E19
410111000.....	E5	422CR023W.....	E21	524931000.....	E5	68PMT-6-8.....	C29, E19
410121000.....	E5	422CR024W.....	E21	524A11000.....	E4	68PMT-8-4.....	C29, E19
410151000.....	E5	422CS011K.....	E21	524A51000.....	E4	68PMT-8-6.....	C29, E19
410211000.....	E4	422CS011W.....	E21	529811000.....	E4	68PMT-8-8.....	C29, E19
410221000.....	E4	422CS013W.....	E21	529831000.....	E4	91213202SXZ.....	C6
410251000.....	E4	422CS014W.....	E21	5500A2004.....	E56, F10	91213202SXZN.....	C6
410411000.....	E3	422CS021K.....	E21	5500A4004.....	E56, F10	91213204SXZ.....	C6
410421000.....	E3	422CS021W.....	E21	5500A6004.....	F10	91213204SXZN.....	C6
410451000.....	E3	422CS023W.....	E21	5500A9004.....	E56, F10	91213206SXZ.....	C6
410711000.....	E5	422CS024W.....	E21	5500B6004.....	E56	91213206SXZN.....	C6
410721000.....	E5	422CT011K.....	E21	62PM.....	D26, D27	91213208SXZ.....	C6
410751000.....	E5	422CT021K.....	E21	68PLCK-4M-2G.....	F36	91213208SXZN.....	C6
410811000.....	E3	520008050.....	E7	68PLCK-4M-M5.....	F36	91213210SXZ.....	C6
410821000.....	E3	520008500.....	E7	68PLCK-5/32-0.....	F35	91213210SXZN.....	C6
410931000.....	E3	520018005.....	E7	68PLCK-6M-2G.....	F36	912132BPSXZ.....	C6
410941000.....	E3	520211000.....	E4	68PLCK-6M-4G.....	F36	9121594805X.....	C6
410951000.....	E3	520251000.....	E4	68PLCK-8M-2G.....	F36	9121594805XN.....	C6
414111000.....	E5	520411000.....	E3	68PLCK-8M-4G.....	F36	9121594806X.....	C6
414121000.....	E5	520431000.....	E3	68PLCKI-10M-6G.....	F36	9121594806XN.....	C6
414151000.....	E5	520451000.....	E3	68PLCKI-12M-6G.....	F36	9121594807X.....	C6

Part Number Index

Safety Guide

Offer of Sale

Part Number Index, Safety Guide, Offer of Sale



For inventory, lead time, and kit lookup, visit www.pdnplu.com

Model No.	Section / Page No.	Model No.	Section / Page No.	Model No.	Section / Page No.	Model No.	Section / Page No.
9121594807XN.....	C6	A05PS.....	C89	A5VC5-MG.....	F36	ASN-15.....	C28, E17, F11
9121594808X.....	C6	A05PS251P.....	C84	A6VC6-MG.....	F36	ASO500-1W-10.....	C82
9121594808XN.....	C6	A05PSCC.....	C88	AAHMD5249MOM.....	D9	ASO500-1W-90.....	C82
9121594809X.....	C6, C21	A05PSCCM.....	C88	AAHMT5129MOM.....	D10	ASV13000-AA-94.....	C80
9121594812X.....	C6	A05PXG.....	C89	AAHMW5209MOM.....	D11	ASV15000-AA-92.....	C81
9121594812XN.....	C6	A05RABM5.....	C89	AAHMX5209MOM.....	D11	ASV2000-AA-17.....	C78
9121658063.....	C6	A05RAIEM5.....	C88	AAPL2AXGAXG##NP.....	C21	ASV2000-AA-97.....	C78
9121658068.....	C6	A05RAISM5.....	C88	AAPL2AXGAXN##NP.....	C21	ASV200-AA-M5.....	C77
9121658068N.....	C6	A05RAXIEM5.....	C88	AAPL2AXMAXG##NP.....	C21	ASV5000-AA-21.....	C79
9121658075.....	C6	A05RAXISM5.....	C88	AAPL2AXMAXN##NP.....	C21	ASV5000-AA-91.....	C79
9121658075N.....	C6	A05RBF.....	C89	AAPL2BXGAXG##NP.....	C21	B310BB549C.....	C42
9121658076.....	C6	A05RBS.....	C89	AAPL2BXGAXN##NP.....	C21	B310BB553C.....	C42
9121658076N.....	C6	A05RD251PM5MF.....	C84	AAPL2BXMAXG##NP.....	C21	B31VBB549C.....	C42
9121658077.....	C6	A05RG.....	C89	AAPL2BXMAXN##NP.....	C21	B31VBB553C.....	C42
9121658077N.....	C6	A05RGBP.....	C88	AAPL2CXMAXG##NP.....	C21	B320BB549C.....	C42
9121658078.....	C6	A05RS.....	C89	AAPL2CXMAXN##NP.....	C21	B320BB553C.....	C42
9121658078N.....	C6	A05RS251PM5MF.....	C84	AAPSG3BXG##NP.....	C49	B32VBB549C.....	C42
988A30.....	E56	A12PAIEN1.....	C88	AAPSG3BXN##NP.....	C49	B32VBB553C.....	C42
A00S-B-M3.....	C87	A12PAISN1.....	C88	AAPSG5BXG##NP.....	C49	B330000XXC.....	C44
A00SBP.....	C88	A12PAXIEN1.....	C88	AAPSG5BXN##NP.....	C49	B33V000XXC.....	C44
A00SC23-1P.....	C87	A12PAXISN1.....	C88	AAPSG6BXG##NP.....	C49	B340000XXC.....	C44
A00SG.....	C89	A12PBG2.....	C85	AAPSG6BXN##NP.....	C49	B34V000XXC.....	C44
A00SS.....	C89	A12PBN2.....	C85	AAPSG6BXN##NP.....	C49	B350BB549C.....	C43
A05P-AC-CL10.....	C88	A12PD252P.....	C84	AAPSJ3B1G##GP.....	C50	B350BB553C.....	C43
A05P-AC-CL5.....	C88	A12PG.....	C89	AAPSM3BXG##NP.....	C49	B35VBB549C.....	C43
A05PAIEM5.....	C88	A12PGBP.....	C88	AAPSM3BXN##NP.....	C49	B35VBB553C.....	C43
A05PAISM5.....	C88	A12PS.....	C89	AAPSM5BXG##NP.....	C49	B360BB549C.....	C43
A05PAXIEM5.....	C88	A12PS252P.....	C84	AAPSM5BXN##NP.....	C49	B360BB553C.....	C43
A05PAXISM5.....	C88	A12PXG.....	C89	AAPSM6BXG##NP.....	C49	B36VBB549C.....	C43
A05PBG1.....	C85	A12RABG1.....	C89	AAPSM6BXN##NP.....	C49	B36VBB553C.....	C43
A05PBN1.....	C85	A12RABN1.....	C89	AAPSM7BXG##NP.....	C49	B370BB549C.....	C43
A05PD251P.....	C84	A12RAIEN1.....	C88	AAPSM7BXN##NP.....	C49	B370BB553C.....	C43
A05PDCC.....	C88	A12RAISN1.....	C88	AS-5.....	C28, E17, F11	B37VBB549C.....	C43
A05P-DC-CB10.....	C88	A12RAXIEN1.....	C88	AS-6.....	C28, E17, F11	B37VBB553C.....	C43
A05P-DC-CL10.....	C88	A12RAXISN1.....	C88	AS-8.....	C28, E17, F11	B380000XXC.....	C44
A05P-DC-CL30.....	C88	A12RBF.....	C89	AS-10.....	C28, E17, F11	B38V000XXC.....	C44
A05P-DC-CL5.....	C88	A12-RBS.....	C89	AS-15.....	C28, E17, F11	B3G0BB549C.....	C42
A05PDCCM.....	C88	A12RD252PN1MF.....	C84	ASC500-1W-10.....	C82	B3G0BB553C.....	C42
A05PG.....	C89	A12RG.....	C89	ASC500-1W-90.....	C82	B3K0000XXC.....	C44
A05PG-BP.....	C88	A12RGBP.....	C88	ASC-D24-CL10.....	C82	B511BB549C.....	C42
A05PLA.....	C88	A12RS.....	C89	ASN-6.....	C28, E17, F11	B511BB553C.....	C42
A05PLB.....	C88	A12RS252PN1MF.....	C84	ASN-8.....	C28, E17, F11	B512BB549C.....	C42
A05PN.....	C89	A4VC4-MG.....	F36	ASN-10.....	C28, E17, F11	B512BB553C.....	C42

Part Number Index

Safety Guide

Offer of Sale

Part Number Index, Safety Guide, Offer of Sale



For inventory, lead times, and kit lookup, visit www.pdnplu.com

Model No.	Section / Page No.	Model No.	Section / Page No.	Model No.	Section / Page No.	Model No.	Section / Page No.
B521BB549C.....	C42	B6X2000XXA.....	C44	BL67-1RS485/422.....	D170, D171, D174, D180	BL67-8DO-0.5A-P.....	D170, D171, D172, D176
B521BB553C.....	C42	B713BB549A.....	C42	BL67-1RSM-VO.....	D170	BL67-8DO-R-NO.....	D170, D171, D173, D177
B522BB549C.....	C42	B713BB553A.....	C42	BL67-1SSI.....	D170, D171, D174, D181	BL67-8XSG-PD.....	D170, D171, D173
B522BB553C.....	C42	B723BB549A.....	C42	BL67-2AI2AO-V/I.....	D174, D179	BL-67-8XSG-PD.....	D177
B531000XXC.....	C44	B723BB553A.....	C42	BL67-2AI-I.....	D170, D171, D173, D178	BL67-B-1M12.....	D170, D174
B532000XXC.....	C44	B733000XXA.....	C44	BL67-2AI-PT.....	D170, D171, D173, D178	BL67-B-1M12-8..	D170, D174
B541000XXC.....	C44	B743000XXA.....	C44	BL67-2AI-TC.....	D170, D171, D173, D178	BL67-B-1M23.....	D170, D172, D174
B542000XXC.....	C44	B753BB549A.....	C43	BL67-2AI-V.....	D170, D171, D173, D178	BL67-B-1M23-19	D170, D173
B551BB549C.....	C43	B753BB553A.....	C43	BL67-2AO-I.....	D170, D171, D173, D179	BL67-B-1RSM.....	D170, D174, D183
B551BB553C.....	C43	B763BB549A.....	C43	BL67-2AO-V.....	D170, D171, D173, D179	BL67-B-1RSM-4.....	D170, D174, D183
B552BB549C.....	C43	B763BB553A.....	C43	BL67-2RFID-A.....	D170	BL67-B-1RSM-VO.....	D174
B552BB553C.....	C43	B773BB549A.....	C43	BL67-2RFID-C.....	D170	BL67-B-2M12.....	D170, D172, D173
B561BB549C.....	C43	B773BB553A.....	C43	BL67-4AI4AO-V/I.....	D174, D179	BL67-B-4M12.....	D170, D172, D173, D174
B561BB553C.....	C43	B783000XXA.....	C44	BL67-4AI-I/V.....	D171	BL67-B-4M12P.....	D173
B562BB549C.....	C43	B7V3BB549A.....	C42	BL67-4AI-V/I.....	D170, D173, D178	BL67-B-4M12-P.....	D170, D172, D173
B562BB553C.....	C43	B7V3BB553A.....	C42	BL67-4AO-V.....	D173	BL67-B-4M8.....	D170, D172
B571BB549C.....	C43	B7X3000XXA.....	C44	BL67-4DI4DO-PD.....	D170, D171, D173, D177	BL67-B-8M8.....	D170, D172, D173, D174
B571BB553C.....	C43	B814BB549A.....	C42	BL67-4DI-N.....	D170, D171, D172, D175	BL67-GW-CO.....	D168
B572BB549C.....	C43	B814BB553A.....	C42	BL67-4DI-P.....	D170, D171, D172, D175	BL67-GW-DN.....	D168
B572BB553C.....	C43	B824BB549A.....	C42	BL67-4DI-PD.....	D170, D171, D172, D175	BL67-GW-DPV1.....	D168
B581000XXC.....	C44	B824BB553A.....	C42	BL67-4DO-0.5A-P.....	D170, D171, D172, D176	BL67-GW-EN.....	D168
B582000XXC.....	C44	B834000XXA.....	C44	BL67-4DO-2A-N.....	D170, D171, D172, D176	BL67-GW-EN-DN.....	D169
B5G1BB549C.....	C42	B844000XXA.....	C44	BL67-4DO-2A-P.....	D170, D171, D172, D176	BL67-GW-EN-IP-DN.....	D169
B5G1BB553C.....	C42	B854BB549A.....	C43	BL67-8DI-N.....	D170, D172, D175	BL67-PF-24VDC.....	D170, D171, D174, D180, D183
B5G2BB549C.....	C42	B854BB553A.....	C43	BL67-8DI-P.....	D170, D171, D172, D175	BL67-PG-DP.....	D169
B5G2BB553C.....	C42	B864BB549A.....	C43	BL67-8DI-PD.....	D170, D171, D172, D175	BL67-PG-EN.....	D169
B5K1000XXC.....	C44	B864BB553A.....	C43	BL67-8DI-PD.....	D170, D171, D172, D175	BL67-PG-EN-DN.....	D169
B5K2000XXC.....	C44	B874BB549A.....	C43	BL67-8DI-PD.....	D170, D171, D172, D175	BL67-PG-EN-IP.....	D169
B612BB549A.....	C42	B874BB553A.....	C43	BL67-8DI-PD.....	D170, D171, D172, D175	BL67-PG-EN-IP-DN.....	D169
B612BB553A.....	C42	B884000XXA.....	C44	BL67-8DI-PD.....	D170, D171, D172, D175	CMD04-1.....	D34, D38, D42, D56
B622BB549A.....	C42	B8V4BB549A.....	C42	BL67-8DI-PD.....	D170, D171, D172, D175	CMD06-1.....	D34, D38, D42, D56
B622BB553A.....	C42	B8V4BB553A.....	C42	BL67-8DI-PD.....	D170, D171, D172, D175		
B632000XXA.....	C44	B8X4000XXA.....	C44	BL67-8DI-PD.....	D170, D171, D172, D175		
B642000XXA.....	C44	BC03M3.....	C89	BL67-8DI-PD.....	D170, D171, D172, D175		
B652BB549A.....	C43	BC03M5.....	C89	BL67-8DI-PD.....	D170, D171, D172, D175		
B652BB553A.....	C43	BC04M3.....	C89	BL67-8DI-PD.....	D170, D171, D172, D175		
B662BB549A.....	C43	BL67-16DO-0.1A-P.....	D170, D171, D173, D176	BL67-8DI-PD.....	D170, D171, D172, D175		
B662BB553A.....	C43	BL67-1CNT/ENC.....	D170, D171, D174, D181	BL67-8DI-PD.....	D170, D171, D172, D175		
B672BB549A.....	C43	BL67-1CVI.....	D170, D171, D174, D181	BL67-8DI-PD.....	D170, D171, D172, D175		
B672BB553A.....	C43	BL67-1RS232.....	D170, D171, D174, D180	BL67-8DI-PD.....	D170, D171, D172, D175		
B682000XXA.....	C44			BL67-8DI-PD.....	D170, D171, D172, D175		
B6V2BB549A.....	C42			BL67-8DI-PD.....	D170, D171, D172, D175		
B6V2BB553A.....	C42			BL67-8DI-PD.....	D170, D171, D172, D175		

Part Number Index

Safety Guide

Offer of Sale

Part Number Index, Safety Guide, Offer of Sale



For inventory, lead time, and kit lookup, visit www.pdnplu.com

Model No.	Section / Page No.	Model No.	Section / Page No.	Model No.	Section / Page No.	Model No.	Section / Page No.
CMD06-2	D34, D38, D42, D56	DX02-451-60	D204, D216	DX2-616-BL53	D216	EM25	C28, C89, E17, F8
CMD07-1B	D34, D38, D42, D56	DX02-606-951J	D204	DX2-616-CL49	D216	EM37	C28, E17, F8
CMD07-2B	D34, D38, D42, D56	DX02-606-951M	D204	DX2-616-CL53	D216	EM50	C28, E17, F8
CMD08-2	D34, D38, D42, D56	DX02-611-951J	D204	DX2-621-BL49	D216	EM75	F8
CMD09-2B	D34, D38, D42, D56	DX02-611-951M	D204	DX2-621-BL53	D216	EM100	F8
CMD10-2	D34, D38, D42, D56	DX02-616-951J	D204	DX2-621-CL49	D216	EM125	F8
CMD12-2	D34, D38, D42, D56	DX02-616-951M	D204	DX2-621-CL53	D216	EM150	F8
CSCM CKCM 12-11-x/S90	D185	DX02-621-951J	D204	DX2-651-BL49	D216	EMM5	F8
CSM CKM 19-19-x/S90	D185	DX02-621-951M	D204	DX2-651-BL53	D216	ES25MC	E56, F9
CSWM CKWM 19-19-x/CS12852	D185	DX02-651-951J	D204	DX2-651-CL49	D216	ES37MC	E56, F9
D01BD0	D214	DX02-651-951M	D204	DX2-651-CL53	D216	ES50MC	E56, F9
D01P-02-80	D77, D102, D214	DX02M2MB	D129, D205, D214	DX3-406-60	D217	ES75MC	E56, F9
D02BD0	D214	DX02M2MGSKT	D214	DX3-411-60	D217	ES100MC	E56, F9
D02P-01-80	D75, D101, D214	DX1-606-BL49	D215	DX3-416-60	D217	ES125MC	E56, F9
DSS25FB1	C88	DX1-606-BL53	D215	DX3-421-60	D217	ES12MC	F9
DX01-406-60	D205, D215	DX1-606-CL49	D215	DX3-451-60	D217	ES150MC	E56, F9
DX01-411-60	D205, D215	DX1-606-CL53	D215	DX3-606-BL49	D217	ES200MC	E56
DX01-416-60	D205, D215	DX1-606-CL53	D215	DX3-606-BL53	D217	ESB12MC	F9
DX01-421-60	D205, D215	DX1-611-BL49	D215	DX3-606-CL49	D217	ESB25MC	F9
DX01-451-60	D205, D215	DX1-611-BL53	D215	DX3-606-CL53	D217	ESB37MC	F9
DX01-606-951J	D205	DX1-611-CL49	D215	DX3-611-BL49	D217	ESB50MC	F9
DX01-606-951M	D205	DX1-611-CL53	D215	DX3-611-BL53	D217	ESB75MC	F9
DX01-611-951J	D205	DX1-616-BL49	D215	DX3-611-BL53	D217	ESB100MC	F9
DX01-611-951M	D205	DX1-616-BL53	D215	DX3-611-CL49	D217	ESB125MC	F9
DX01-616-951J	D205	DX1-616-CL49	D215	DX3-611-CL53	D217	ESB150MC	F9
DX01-616-951M	D205	DX1-616-CL53	D215	DX3-616-BL49	D217	EZ03NB6	E54
DX01-621-951J	D205	DX1-621-BL49	D215	DX3-616-BL53	D217	EZ04NB6	E54
DX01-621-951M	D205	DX1-621-BL53	D215	DX3-616-CL49	D217	EZ06NB6	E54
DX01-651-951J	D205	DX1-621-CL49	D215	DX3-616-CL53	D217	EZ06NBA	E54
DX01-651-951M	D205	DX1-621-CL53	D215	DX3-621-BL49	D217	EZ08NBA	E54
DX01M2MGSKT	D205, D214	DX1-651-BL49	D215	DX3-621-BL53	D217	EZOANBA	E54
DX02-406-60	D204, D216	DX1-651-BL53	D215	DX3-621-CL49	D217	FC601-10M-6G	F37
DX02-411-60	D204, D216	DX1-651-CL49	D215	DX3-621-CL53	D217	FC601-12M-8G	F37
DX02-416-60	D204, D216	DX2-606-BL49	D216	DX3-651-BL49	D217	FC601-4-2	F37
DX02-421-60	D204, D216	DX2-606-CL49	D216	DX3-651-BL53	D217	FC601-4-4	F37
		DX2-606-CL53	D216	DX3-651-CL49	D217	FC601-6-6	F37
		DX2-611-BL49	D216	DX3-651-CL53	D217	FC601-6M-2G	F37
		DX2-611-BL53	D216	E9001*	C28	FC601-6M-4G	F37
		DX2-611-CL49	D216	E90016	E17	FC601-8-8	F37
		DX2-611-CL53	D216	E90017	C28	FC601-8M-4G	F37
		DX2-616-BL49	D216	E90017	E17	FC601-8M-6G	F37
				ECS3	F13	FC602-2	F37
				ECS5	F13	FC602-4	F37
				EM12	C28, C89, E17, F8		

Part Number Index

Safety Guide

Offer of Sale

Part Number Index, Safety Guide, Offer of Sale



For inventory, lead times, and kit lookup, visit www.pdnplu.com

Model No.	Section / Page No.	Model No.	Section / Page No.	Model No.	Section / Page No.	Model No.	Section / Page No.
FC602-6.....	F37	FC836-2G.....	F33	FCCS731-6-4.....	F30	FCM731-2-0.....	F29
FC602-8.....	F37	FC836-4.....	F33	FCCS731-6-6.....	F30	FCM731-2-2.....	F29
FC608-4G-2G.....	F37	FC836-4G.....	F33	FCCS731-6M-2G.....	F30	FCM731-3M-M3.....	F29
FC608-4G-4G.....	F37	FC836-6.....	F33	FCCS731-6M-4G.....	F30	FCM731-3M-M5.....	F29
FC608-6G-6G.....	F37	FC836-6G.....	F33	FCCS731-8M-2G.....	F30	FCM731-4-0.....	F29
FC608-8G-8G.....	F37	FC836-8.....	F33	FCCS731-8M-4G.....	F30	FCM731-4-2.....	F29
FC701-10M-4G.....	F34	FC836-8G.....	F33	FCCS731-8M-6G.....	F30	FCM731-4-4.....	F29
FC701-10M-6G.....	F34	FCB832-4.....	F32	FCCSP731-6M.....	F31	FCM731-4M-2G.....	F29
FC701-12M-6G.....	F34	FCB832-4M.....	F32	FCCSP731-8M.....	F31	FCM731-4M-M3.....	F29
FC701-12M-8G.....	F34	FCB832-5.....	F32	FCCSP731-10M.....	F31	FCM731-4M-M5.....	F29
FC701-14M-8G.....	F34	FCB832-5/32.....	F32	FCCSP731-12M.....	F31	FCM731-5/32-0.....	F29
FC701-4M-2G.....	F34	FCB832-6M.....	F32	FCKC731-10M-4G.....	F28	FCM731-5/32-2.....	F29
FC701-6M-2G.....	F34	FCB832-8M.....	F32	FCKC731-10M-6G.....	F28	FCM731-6M-2G.....	F29
FC701-6M-4G.....	F34	FCC731-10M-4G.....	F27	FCKC731-10M-8G.....	F28	FCM731-6M-4G.....	F29
FC701-8M-2G.....	F34	FCC731-10M-6G.....	F27	FCKC731-12M-6G.....	F28	FCM731-6M-M5.....	F29
FC701-8M-4G.....	F34	FCC731-12M-6G.....	F27	FCKC731-12M-8G.....	F28	FCM731-8M-2G.....	F29
FC701-8M-6G.....	F34	FCC731-12M-8G.....	F27	FCKC731-2-0.....	F28	FCM731-8M-4G.....	F29
FC702-2G.....	F34	FCC731-4-2.....	F27	FCKC731-2-2.....	F28	FCM731-8M-6G.....	F29
FC702-4G.....	F34	FCC731-4-4.....	F27	FCKC731-4-0.....	F28	FCMB731-4M-2G.....	F29
FC702-6G.....	F34	FCC731-4M-2G.....	F27	FCKC731-4-2.....	F28	FCMB731-4M-M5.....	F29
FC702-8G.....	F34	FCC731-5/32-2.....	F27	FCKC731-4-4.....	F28	FCMB731-6M-2G.....	F29
FC705-4-2.....	F34	FCC731-5/32-4.....	F27	FCKC731-4M-2G.....	F28	FCMB731-6M-4G.....	F29
FC705-4-4.....	F34	FCC731-6-4.....	F27	FCKC731-4M-M5.....	F28	FCMB731-6M-M5.....	F29
FC705-5/32-2.....	F34	FCC731-6-6.....	F27	FCKC731-5/32-0.....	F28	FCMK731-2-0.....	F29
FC705-6-4.....	F34	FCC731-6M-2G.....	F27	FCKC731-5/32-2.....	F28	FCMK731-2-2.....	F29
FC705-6-6.....	F34	FCC731-6M-4G.....	F27	FCKC731-5-2.....	F28	FCMK731-4-0.....	F29
FC708-2.....	F34	FCC731-8M-2G.....	F27	FCKC731-5-4.....	F28	FCMK731-4-2.....	F29
FC708-4.....	F34	FCC731-8M-4G.....	F27	FCKC731-6-4.....	F28	FCMK731-4-4.....	F29
FC708-6.....	F34	FCC731-8M-6G.....	F27	FCKC731-6-6.....	F28	FCMK731-5/32-0.....	F29
FC708-8.....	F34	FCCB731-4-2.....	F27	FCKC731-6M-2G.....	F28	FCMK731-5/32-2.....	F29
FC800-5/32.....	D9	FCCB731-4M-2G.....	F27	FCKC731-6M-4G.....	F28	FCMS731-4M-2G.....	F30
FC832-4.....	D9	FCCB731-5/32-2.....	F27	FCKC731-6M-M5.....	F28	FCMS731-4M-M5.....	F30
FC832-4.....	F32	FCCB731-6M-2G.....	F27	FCKC731-8M-2G.....	F28	FCMS731-5/32-0.....	F30
FC832-4M.....	F32	FCCB731-6M-4G.....	F27	FCKC731-8M-4G.....	F28	FCMS731-5/32-2.....	F30
FC832-5.....	F32	FCCB731-8M-2G.....	F27	FCKC731-8M-6G.....	F28	FCMS731-6M-2G.....	F30
FC832-5/32.....	F32	FCCB731-8M-4G.....	F27	FCKCB731-4M-2G.....	F28	FCMS731-6M-M5.....	F30
FC832-6.....	F32	FCCB731-8M-6G.....	F27	FCKCB731-4M-M5.....	F28	FCMSP701-4M.....	F31
FC832-6M.....	F32	FCCS731-10M-4G.....	F30	FCKCB731-6M-2G.....	F28	FCMSP701-6M.....	F31
FC832-8.....	F32	FCCS731-10M-6G.....	F30	FCKCB731-6M-4G.....	F28	FCMSP731-2.....	F31
FC832-8M.....	F32	FCcS731-12M-6G.....	F30	FCKCB731-6M-M5.....	F28	FCMSP731-4.....	F31
FC832-10M.....	F32	FCcS731-12M-8G.....	F30	FCKCB731-8M-2G.....	F28	FCMSP731-5/32.....	F31
FC832-12M.....	F32	FCCS731-4-2.....	F30	FCKCB731-8M-4G.....	F28	FCPM832-4M.....	F33
FC836-2.....	F33	FCCS731-4-4.....	F30	FCKCB731-8M-6G.....	F28	FCPM832-6M.....	F33

Part Number Index

Safety Guide

Offer of Sale

Part Number Index, Safety Guide, Offer of Sale



For inventory, lead time, and kit lookup, visit www.pdnplu.com

Model No.	Section / Page No.	Model No.	Section / Page No.	Model No.	Section / Page No.	Model No.	Section / Page No.
FCPM832-8M	F33	H100107	D259	H12VXBH0B9D	D85	H15VXBH023D	D85
FCPM832-10M	F33	H10032	D259	H12VXXG023D	D85	H15VXBH0B9D	D85
FCPM832-12M	F33	H10069	D259	H12VXXG0B9D	D85	H15VXXG023D	D85
FMD04-1	D34, D38, D42, D56	H10115	E33	H12VXXH023D	D85	H15VXXG0B9D	D85
FMD06-1	D34, D38, D42, D56	H10117	E32	H12VXXH0B9D	D85	H15VXXH023D	D85
FMD06-2	D34, D38, D42, D56	H10119	E33	H12WXBBL49D	D109	H15VXXH0B9D	D85
FMD07-1B	D34, D38, D42, D45, D56	H10121	E32	H12WXBBL53D	D109	H15WXBBL49D	D109
FMD07-2B	D34, D38, D42, D56	H10145	E32, E33	H12WXBBL49D	D109	H15WXBBL53D	D109
FMD08-2	D34, D38, D42, D56	H10147	E32	H12WXBBL53D	D109	H15WXBBL49D	D109
FMD09-2B	D34, D38, D42, D56	H10215	E32	H12WXBG2B9000FD	D108	H15WXBBL53D	D109
FMD10-2	D34, D38, D42, D56	H10217	E33	H12WXBG2B9000FD	D108	H15WXBG2B9000FD	D108
FMD12-2	D34, D38, D42, D56	H10219	E32	H12WXBH2B9000FD	D108	H15WXBG323000FD	D108
FMD13-2B	D34, D42, D56	H11215	E34	H12WXBH323000FD	D108	H15WXBH2B9000FD	D108
H02713	D261	H11216	E34	H12WXXBL49D	D109	H15WXBH323000FD	D108
H02722	D261	H11217	E34	H12WXXBL53D	D109	H15WXXBL49D	D109
H02723	D261	H11333	E33	H12WXXDL49D	D109	H15WXXBL53D	D109
H02789	D261	H11VXBG023D	D85	H12WXXDL53D	D109	H15WXXDL49D	D109
H05028	E30, E31	H11VXBG0B9D	D85	H12WXXG2B9000FD	D108	H15WXXDL53D	D109
H05029	E31	H11VXBH023D	D85	H12WXXG323000FD	D108	H15WXXG2B9000FD	D108
H06326	C107, C108, C111, C112	H11VXBH0B9D	D85	H12WXXH2B9000FD	D108	H15WXXG323000FD	D108
H06332	C107, C108, C111, C112	H11VXXG023D	D85	H12WXXH323000FD	D108	H15WXXH2B9000FD	D108
H06338	C109, C110, C111, C112	H11VXXG0B9D	D85	H13466	E29	H15WXXH323000FD	D108
H06416	E33	H11VXXH023D	D85	H13473	C101	H16VXBG023D	D85
H07229	E30, E31	H11VXXH0B9D	D85	H13499	C111, C112	H16VXBG0B9D	D85
H07230	E30	H11WXBBL49D	D109	H13529	C112	H16VXBH023D	D85
H07254	E34	H11WXBBL53D	D109	H13580	E29	H16VXBH0B9D	D85
H07270	E34	H11WXBBL49D	D109	H13584	E29	H16VXXG023D	D85
H07271	E34	H11WXBBL53D	D109	H13588	E29	H16VXXG0B9D	D85
H08903	E30, E31	H11WXBG2B9000FD	D108	H13648	C107, C108, C111, C112	H16VXXH023D	D85
H09012	E34	H11WXBG323000FD	D108	H13676	C107, C108, C111, C112	H16VXXH0B9D	D85
H09025	E34	H11WXBH2B9000FD	D108	H13728	C107, C108, C109, C110, C111, C112	H16WXBBL49D	D109
H09626	E34, E35	H11WXBH323000FD	D108	H13752	C109, C110, C111, C112	H16WXBBL53D	D109
H09645	E34, E35	H11WXXBL49D	D109	H14213	C101	H16WXBBL49D	D109
H09706	E34, E35	H11WXXBL53D	D109	H14215	C103	H16WXBBL53D	D109
H09815	D259	H11WXXDL49D	D109	H14509	C107	H16WXBBL49D	D109
		H11WXXDL53D	D109	H14510	C107, C111	H16WXBBL53D	D109
		H11WXXG2B9000FD	D108	H14515	E32	H16WXXBL53D	D109
		H11WXXG323000FD	D108	H14520	E32	H16WXXDL49D	D109
		H12VXBG023D	D85	H15VXBG023D	D85	H16WXXDL53D	D109
		H12VXBG0B9D	D85	H15VXBG0B9D	D85	H16WXXG2B9000FD	D108
		H12VXBH023D	D85				

Part Number Index
Safety Guide
Offer of Sale
Part Number Index, Safety Guide, Offer of Sale



For inventory, lead times, and kit lookup, visit www.pdnplu.com

Model No.	Section / Page No.	Model No.	Section / Page No.	Model No.	Section / Page No.	Model No.	Section / Page No.
H16WXXG323000FD.....	D108	H19102.....	C101	H21WXXCL49D.....	D112	H25WXBCL53D.....	D113
H16WXXH2B9000FD.....	D108	H1EVXBG023D.....	D85	H21WXXCL53D.....	D113	H25WXBG2B9000FD.....	D112
H16WXXH323000FD.....	D108	H1EVXBG0B9D.....	D85	H21WXXG2B9000FD.....	D112	H25WXBG323000FD.....	D112
H17408.....	E30, E31, E32, E33, E34, E35	H1EVXBH023D.....	D85	H21WXXG323000FD.....	D112	H25WXBH2B9000FD.....	D112
H17509.....	D259	H1EVXBH0B9D.....	D85	H21WXXH2B9000FD.....	D112	H25WXBH323000FD.....	D112
H17511.....	D259	H1EVXXG023D.....	D85	H21WXXH323000FD.....	D112	H25WXXBL49D.....	D112
H17512.....	D259	H1EVXXG0B9D.....	D85	H22232.....	E32	H25WXXBL53D.....	D113
H17514.....	E32	H1EVXXH023D.....	D85	H22VXBG023D.....	D88	H25WXXCL49D.....	D112
H17519.....	E32	H1EVXXH0B9D.....	D85	H22VXBG0B9D.....	D88	H25WXXCL53D.....	D113
H17524.....	E32	H1EWXBBL49D.....	D109	H22VXBH023D.....	D88	H25WXXG2B9000FD.....	D112
H17705.....	E30, E31, E32, E33, E34, E35	H1EWXBBL53D.....	D109	H22VXBH0B9D.....	D88	H25WXXG323000FD.....	D112
H17706.....	E30, E31, E32, E33, E34, E35	H1EWXBDL49D.....	D109	H22VXXG023D.....	D88	H25WXXH2B9000FD.....	D112
H17706.....	E30, E31, E32, E33, E34, E35	H1EWXBDL53D.....	D109	H22VXXG0B9D.....	D88	H25WXXH323000FD.....	D112
H17811.....	C107, C108, C111, C112	H1EWXBG2B9000FD.....	D108	H22VXXH023D.....	D88	H26VXBG023D.....	D88
H17813.....	C107, C108, C111, C112	H1EWXBG323000FD.....	D108	H22VXXH0B9D.....	D88	H26VXBG0B9D.....	D88
H17817.....	C109, C110, C111, C112	H1EWXBH2B9000FD.....	D108	H22WXBBL49D.....	D112	H26VXBH023D.....	D88
H17VXBG023D.....	D85	H1EWXBH323000FD.....	D108	H22WXBBL53D.....	D113	H26VXBH0B9D.....	D88
H17VXBG0B9D.....	D85	H1EWXXBL49D.....	D109	H22WXBCL49D.....	D112	H26VXXG023D.....	D88
H17VXBH023D.....	D85	H1EWXXBL53D.....	D109	H22WXBCL53D.....	D113	H26VXXG0B9D.....	D88
H17VXBH0B9D.....	D85	H1EWXXDL49D.....	D109	H22WXBCL53D.....	D113	H26VXXH023D.....	D88
H17VXXG023D.....	D85	H1EWXXDL53D.....	D109	H22WXBG2B9000FD.....	D112	H26VXXH0B9D.....	D88
H17VXXG0B9D.....	D85	H1EWXXG2B9000FD.....	D108	H22WXBH2B9000FD.....	D112	H26WXBBL49D.....	D112
H17VXXH023D.....	D85	H1EWXXG323000FD.....	D108	H22WXBH323000FD.....	D112	H26WXBBL53D.....	D113
H17VXXH0B9D.....	D85	H1EWXXH2B9000FD.....	D108	H22WXXBL49D.....	D112	H26WXBCL49D.....	D112
H17VXXH0B9D.....	D85	H1EWXXH323000FD.....	D108	H22WXXBL53D.....	D113	H26WXBCL53D.....	D113
H17WXBBL49D.....	D109	H21VXBG023D.....	D88	H22WXXCL49D.....	D112	H26WXBCL53D.....	D113
H17WXBBL53D.....	D109	H21VXBG0B9D.....	D88	H22WXXCL53D.....	D113	H26WXBG2B9000FD.....	D112
H17WXBBDL49D.....	D109	H21VXBG0B9D.....	D88	H22WXXCL53D.....	D113	H26WXBG323000FD.....	D112
H17WXBBDL53D.....	D109	H21VXBH023D.....	D88	H22WXXG2B9000FD.....	D112	H26WXBH2B9000FD.....	D112
H17WXBG2B9000FD.....	D108	H21VXBH0B9D.....	D88	H22WXXG323000FD.....	D112	H26WXBH323000FD.....	D112
H17WXBG323000FD.....	D108	H21VXXG023D.....	D88	H22WXXH2B9000FD.....	D112	H26WXXBL49D.....	D112
H17WXBH2B9000FD.....	D108	H21VXXG0B9D.....	D88	H22WXXH323000FD.....	D112	H26WXXBL53D.....	D113
H17WXBH323000FD.....	D108	H21VXXH023D.....	D88	H24969.....	C101, C102	H26WXXCL49D.....	D112
H17WXXBL49D.....	D109	H21VXXH0B9D.....	D88	H25VXBG023D.....	D88	H26WXXCL53D.....	D113
H17WXXBL53D.....	D109	H21WXBBL49D.....	D112	H25VXBG0B9D.....	D88	H26WXXG2B9000FD.....	D112
H17WXXDL49D.....	D109	H21WXBBL53D.....	D113	H25VXBH023D.....	D88	H26WXXG323000FD.....	D112
H17WXXDL53D.....	D109	H21WXBCL49D.....	D112	H25VXBH0B9D.....	D88	H26WXXH2B9000FD.....	D112
H17WXXG2B9000FD.....	D108	H21WXBCL53D.....	D113	H25VXXG023D.....	D88	H26WXXH323000FD.....	D112
H17WXXG323000FD.....	D108	H21WXBCL53D.....	D113	H25VXXG0B9D.....	D88	H27VXBG023D.....	D88
H17WXXH2B9000FD.....	D108	H21WXBG2B9000FD.....	D112	H25VXXH023D.....	D88	H27VXBG0B9D.....	D88
H17WXXH323000FD.....	D108	H21WXBG323000FD.....	D112	H25VXXH0B9D.....	D88	H27VXBH023D.....	D88
H17WXXH323000FD.....	D108	H21WXBH2B9000FD.....	D112	H25WXBBL49D.....	D112	H27VXBH0B9D.....	D88
H17WXXH323000FD.....	D108	H21WXBH323000FD.....	D112	H25WXBBL53D.....	D113	H27VXXG023D.....	D88
H17WXXH323000FD.....	D108	H21WXXBL49D.....	D112	H25WXBCL49D.....	D112	H27VXXG0B9D.....	D88
H17WXXH323000FD.....	D108	H21WXXBL53D.....	D113	H25WXBCL49D.....	D112		

Part Number Index

Safety Guide

Offer of Sale

Part Number Index, Safety Guide, Offer of Sale



For inventory, lead time, and kit lookup, visit www.pdnplu.com

Model No.	Section / Page No.	Model No.	Section / Page No.	Model No.	Section / Page No.	Model No.	Section / Page No.
H27VXXH023D.....D88	D88	H31VXBG0B9D.....D91	D91	H32WXXG2B9000FD.....D115	D115	H36WXBH323000FD.....D115	D115
H27VXXH0B9D.....D88	D88	H31VXBH023D.....D91	D91	H32WXXG323000FD.....D115	D115	H36WXXBL49D.....D115	D115
H27WXBBL49D.....D112	D112	H31VXBH0B9D.....D91	D91	H32WXXH2B9000FD.....D115	D115	H36WXXBL53D.....D116	D116
H27WXBBL53D.....D113	D113	H31VXXG023D.....D91	D91	H32WXXH323000FD.....D115	D115	H36WXXCL49D.....D115	D115
H27WXBCL49D.....D112	D112	H31VXXG0B9D.....D91	D91	H35VXBG023D.....D91	D91	H36WXXCL53D.....D116	D116
H27WXBCL53D.....D113	D113	H31VXXH023D.....D91	D91	H35VXBG0B9D.....D91	D91	H36WXXG2B9000FD.....D115	D115
H27WXBG2B9000FD.....D112	D112	H31VXXH0B9D.....D91	D91	H35VXBH023D.....D91	D91	H36WXXG323000FD.....D115	D115
H27WXBG323000FD.....D112	D112	H31WXBBL49D.....D115	D115	H35VXBH0B9D.....D91	D91	H36WXXH2B9000FD.....D115	D115
H27WXBH2B9000FD.....D112	D112	H31WXBBL53D.....D116	D116	H35VXXG023D.....D91	D91	H36WXXH323000FD.....D115	D115
H27WXBH323000FD.....D112	D112	H31WXBCL49D.....D115	D115	H35VXXG0B9D.....D91	D91	H37VXBG023D.....D91	D91
H27WXXBL49D.....D112	D112	H31WXBCL53D.....D116	D116	H35VXXH023D.....D91	D91	H37VXBG0B9D.....D91	D91
H27WXXBL53D.....D113	D113	H31WXBG2B9000FD.....D115	D115	H35VXXH0B9D.....D91	D91	H37VXBH023D.....D91	D91
H27WXXCL49D.....D112	D112	H31WXBG323000FD.....D115	D115	H35WXBBL49D.....D115	D115	H37VXBH0B9D.....D91	D91
H27WXXCL53D.....D113	D113	H31WXBH2B9000FD.....D115	D115	H35WXBBL53D.....D116	D116	H37VXXG023D.....D91	D91
H27WXXG2B9000FD.....D112	D112	H31WXBH323000FD.....D115	D115	H35WXBCL49D.....D115	D115	H37VXXG0B9D.....D91	D91
H27WXXG323000FD.....D112	D112	H31WXXBL49D.....D115	D115	H35WXBCL53D.....D116	D116	H37VXXH023D.....D91	D91
H27WXXH2B9000FD.....D112	D112	H31WXXBL53D.....D116	D116	H35WXBG2B9000FD.....D115	D115	H37VXXH0B9D.....D91	D91
H27WXXH323000FD.....D112	D112	H31WXXCL49D.....D115	D115	H35WXBG323000FD.....D115	D115	H37WXBBL49D.....D115	D115
H2EVXBG023D.....D88	D88	H31WXXCL53D.....D116	D116	H35WXBH2B9000FD.....D115	D115	H37WXBBL53D.....D116	D116
H2EVXBG0B9D.....D88	D88	H31WXXG2B9000FD.....D115	D115	H35WXBH323000FD.....D115	D115	H37WXBCL49D.....D115	D115
H2EVXBH023D.....D88	D88	H31WXXG323000FD.....D115	D115	H35WXXBL49D.....D115	D115	H37WXBCL53D.....D116	D116
H2EVXBH0B9D.....D88	D88	H31WXXH2B9000FD.....D115	D115	H35WXXBL53D.....D116	D116	H37WXBG2B9000FD.....D115	D115
H2EVXXG023D.....D88	D88	H31WXXH323000FD.....D115	D115	H35WXXCL49D.....D115	D115	H37WXBG323000FD.....D115	D115
H2EVXXG0B9D.....D88	D88	H32VXBG023D.....D91	D91	H35WXXCL53D.....D116	D116	H37WXBH2B9000FD.....D115	D115
H2EVXXH023D.....D88	D88	H32VXBG0B9D.....D91	D91	H35WXXG2B9000FD.....D115	D115	H37WXBH323000FD.....D115	D115
H2EVXXH0B9D.....D88	D88	H32VXBH023D.....D91	D91	H35WXXG323000FD.....D115	D115	H37WXXBL49D.....D115	D115
H2EWXBBL49D.....D112	D112	H32VXBH0B9D.....D91	D91	H35WXXH2B9000FD.....D115	D115	H37WXXBL53D.....D116	D116
H2EWXBBL53D.....D113	D113	H32VXXG023D.....D91	D91	H35WXXH323000FD.....D115	D115	H37WXXCL49D.....D115	D115
H2EWXBCL49D.....D112	D112	H32VXXG0B9D.....D91	D91	H36VXBG023D.....D91	D91	H37WXXCL53D.....D116	D116
H2EWXBCL53D.....D113	D113	H32VXXH023D.....D91	D91	H36VXBG0B9D.....D91	D91	H37WXXG2B9000FD.....D115	D115
H2EWXBG2B9000FD.....D112	D112	H32VXXH0B9D.....D91	D91	H36VXBH023D.....D91	D91	H37WXXG323000FD.....D115	D115
H2EWXBG323000FD.....D112	D112	H32WXBBL49D.....D115	D115	H36VXBH0B9D.....D91	D91	H37WXXH2B9000FD.....D115	D115
H2EWXBH2B9000FD.....D112	D112	H32WXBBL53D.....D116	D116	H36VXXG023D.....D91	D91	H37WXXH323000FD.....D115	D115
H2EWXBH323000FD.....D112	D112	H32WXBCL49D.....D115	D115	H36VXXG0B9D.....D91	D91	H37WXXBL49D.....D115	D115
H2EWXXBL49D.....D112	D112	H32WXBCL53D.....D116	D116	H36VXXH023D.....D91	D91	H37WXXBL53D.....D116	D116
H2EWXXBL53D.....D113	D113	H32WXBG2B9000FD.....D115	D115	H36VXXH0B9D.....D91	D91	H37WXXCL49D.....D115	D115
H2EWXXCL49D.....D112	D112	H32WXBG323000FD.....D115	D115	H36WXBBL49D.....D115	D115	H37WXXCL53D.....D116	D116
H2EWXXCL53D.....D113	D113	H32WXBH2B9000FD.....D115	D115	H36WXBBL53D.....D116	D116	H37WXXG2B9000FD.....D115	D115
H2EWXXG2B9000FD.....D112	D112	H32WXBH323000FD.....D115	D115	H36WXBCL49D.....D115	D115	H37WXXG323000FD.....D115	D115
H2EWXXG323000FD.....D112	D112	H32WXXBL49D.....D115	D115	H36WXBCL53D.....D116	D116	H37WXXH2B9000FD.....D115	D115
H2EWXXH2B9000FD.....D112	D112	H32WXXBL53D.....D116	D116	H36WXBG2B9000FD.....D115	D115	H37WXXH323000FD.....D115	D115
H2EWXXH323000FD.....D112	D112	H32WXXCL49D.....D115	D115	H36WXBG323000FD.....D115	D115	H37WXXBL49D.....D115	D115
H31VXBG023D.....D91	D91	H32WXXCL53D.....D116	D116	H36WXBH2B9000FD.....D115	D115	H37WXXBL53D.....D116	D116

Part Number Index
Safety Guide
Offer of Sale
Part Number Index, Safety Guide, Offer of Sale



For inventory, lead times, and kit lookup, visit www.pdnplu.com

Model No.	Section / Page No.	Model No.	Section / Page No.	Model No.	Section / Page No.	Model No.	Section / Page No.
H3EWXBCL49D	D115	HA5VXLG0G9A	D76	HB1VXBG023A	D74	HB6VXLH0G9A	D74
H3EWXBCL53D	D116	HA5VXLH023A	D76	HB1VXBG0G9A	D74	HB6WXBG2G9000FA	D101
H3EWXBG2B9000FD	D115	HA5VXLH0G9A	D76	HB1VXBH023A	D74	HB6WXBH2G9000FA	D101
H3EWXBG323000FD	D115	HA5WXBG2G9000FA	D102	HB1VXBH0G9A	D74	HB6WXLG2G9000FA	D101
H3EWXBH2B9000FD	D115	HA5WXBH2G9000FA	D102	HB1VXLG023A	D74	HB6WXLH2G9000FA	D101
H3EWXBH323000FD	D115	HA5WXLG2G9000FA	D102	HB1VXLG0G9A	D74	HB7VXBG023A	D74
H3EWXXBL49D	D115	HA5WXLH2G9000FA	D102	HB1VXLH023A	D74	HB7VXBG0G9A	D74
H3EWXXBL53D	D116	HA6VXBG023A	D76	HB1VXLH0G9A	D74	HB7VXBH023A	D74
H3EWXXCL49D	D115	HA6VXBG0G9A	D76	HB1WXBG2G9000FA	D101	HB7VXBH0G9A	D74
H3EWXXCL53D	D116	HA6VXBH023A	D76	HB1WXBH2G9000FA	D101	HB7VXLG023A	D74
H3EWXXG2B9000FD	D115	HA6VXBH0G9A	D76	HB1WXLG2G9000FA	D101	HB7VXLG0G9A	D74
H3EWXXG323000FD	D115	HA6VXLG023A	D76	HB1WXLH2G9000FA	D101	HB7VXLH023A	D74
H3EWXXH2B9000FD	D115	HA6VXLG0G9A	D76	HB2VXBG023A	D74	HB7VXLH0G9A	D74
H3EWXXH323000FD	D115	HA6VXLH023A	D76	HB2VXBG0G9A	D74	HB7WXBG2G9000FA	D101
HA1VXBG023A	D76	HA6VXLH0G9A	D76	HB2VXBH023A	D74	HB7WXBH2G9000FA	D101
HA1VXBG0G9A	D76	HA6WXBG2G9000FA	D102	HB2VXBH0G9A	D74	HB7WXLG2G9000FA	D101
HA1VXBH023A	D76	HA6WXBH2G9000FA	D102	HB2VXLG023A	D74	HB7WXLH2G9000FA	D101
HA1VXBH0G9A	D76	HA6WXLG2G9000FA	D102	HB2VXLG0G9A	D74	HBEVXBG023A	D74
HA1VXLG023A	D76	HA6WXLH2G9000FA	D102	HB2VXLH023A	D74	HBEVXBG0G9A	D74
HA1VXLG0G9A	D76	HA7VXBG023A	D76	HB2VXLH0G9A	D74	HBEVXBH023A	D74
HA1VXLH023A	D76	HA7VXBG0G9A	D76	HB2WXBG2G9000FA	D101	HBEVXBH0G9A	D74
HA1VXLH0G9A	D76	HA7VXBH023A	D76	HB2WXBH2G9000FA	D101	HBEVXLG023A	D74
HA1WXBG2G9000FA	D102	HA7VXBH0G9A	D76	HB2WXLG2G9000FA	D101	HBEVXLG0G9A	D74
HA1WXBH2G9000FA	D102	HA7VXLG023A	D76	HB2WXLH2G9000FA	D101	HBEVXLH023A	D74
HA1WXLG2G9000FA	D102	HA7VXLG0G9A	D76	HB5VXBG023A	D74	HBEVXLH0G9A	D74
HA1WXLH2G9000FA	D102	HA7VXLH023A	D76	HB5VXBG0G9A	D74	HBEWXBG2G9000FA	D101
HA2VXBG023A	D76	HA7VXLH0G9A	D76	HB5VXBH023A	D74	HBEWXBH2G9000FA	D101
HA2VXBG0G9A	D76	HA7WXBG2G9000FA	D102	HB5VXBH0G9A	D74	HBEWXLG2G9000FA	D101
HA2VXBH023A	D76	HA7WXBH2G9000FA	D102	HB5VXLG023A	D74	HBEWXLH2G9000FA	D101
HA2VXBH0G9A	D76	HA7WXLG2G9000FA	D102	HB5VXLG0G9A	D74	HBNVXBG023A	D74
HA2VXLG023A	D76	HA7WXLH2G9000FA	D102	HB5VXLH023A	D74	HBNVXBG0G9A	D74
HA2VXLG0G9A	D76	HAEVXBG023A	D76	HB5VXLH0G9A	D74	HBNVXBH023A	D74
HA2VXLH023A	D76	HAEVXBG0G9A	D76	HB5WXBG2G9000FA	D101	HBNVXBH0G9A	D74
HA2VXLH0G9A	D76	HAEVXBH023A	D76	HB5WXBH2G9000FA	D101	HBNWXBG2G9000FA	D101
HA2WXBG2G9000FA	D102	HAEVXBH0G9A	D76	HB5WXLG2G9000FA	D101	HBNWXBH2G9000FA	D101
HA2WXBH2G9000FA	D102	HAEVXLG023A	D76	HB5WXLH2G9000FA	D101	HBPVXBG023A	D74
HA2WXLG2G9000FA	D102	HAEVXLG0G9A	D76	HB6VXBG023A	D74	HBPVXBG0G9A	D74
HA2WXLH2G9000FA	D102	HAEVXLH023A	D76	HB6VXBG0G9A	D74	HBPVXBH023A	D74
HA5VXBG023A	D76	HAEVXLH0G9A	D76	HB6VXBH023A	D74	HBPVXBH0G9A	D74
HA5VXBG0G9A	D76	HAEWXBG2G9000FA	D102	HB6VXBH0G9A	D74	HBPWXBG2G9000FA	D101
HA5VXBH023A	D76	HAEWXBH2G9000FA	D102	HB6VXLG023A	D74	HBPWXBH2G9000FA	D101
HA5VXBH0G9A	D76	HAEWXLG2G9000FA	D102	HB6VXLG0G9A	D74	HM*VX2049A	D13
HA5VXLG023A	D76	HAEWXLH2G9000FA	D102	HB6VXLH023A	D74	HM2VX2049A	D4, D13, D15

Part Number Index

Safety Guide

Offer of Sale

Part Number Index, Safety Guide, Offer of Sale



For inventory, lead time, and kit lookup, visit www.pdnplu.com

Model No.	Section / Page No.	Model No.	Section / Page No.	Model No.	Section / Page No.	Model No.	Section / Page No.
HM5VX2049A.....D4, D13, D17		K053023	C107, C111	K092046	C109, C110, C111, C112	K21R02037L.....D261, E29	
HMBVX00XXA.....D4, D12		K053025	C107, C111	K103035	C107, C108, C111, C112	K21R02050L.....D261, E29	
HMCVX00XXA.....D4, D12		K053026	C107, C111	K103053	C107, C108, C111, C112	K21R02075L.....D261, E29	
HMDXX1	D34, D38, D42, D56	K053064	C108, C112	K103061	C109, C110, C111, C112	K2352035	D260
HMDXX2	D34, D38, D42, D56	K053065	C108, C112	K112046	C103	K2353035	D260
HMEVX2049A	D4, D9, D10, D11, D13, D14	K053067	C108, C112	K123018	C111	K255202549	C102
HMNVX2049A.....D4, D10, D11, D13, D15		K053069	C108, C112	K123021	C111	K272002	C103
HMPVX2049A...D4, D13, D16		K053070	C108, C112	K123024	C111	K272004	C101
HMQVX2049A...D4, D13, D16		K053075	C107, C111	K123027	C111	K313028	C109, C110, C111, C112
HVN4200-8.....E64		K053076	C107, C111	K123029	C109, C110, C111, C112	K313029	C109, C110, C111, C112
HVN4400-10.....E64		K053077	C107, C111	K1351045	C103	K322004	C103
HVN4400-15.....E64		K053078	C107, C111	K135804553	C103	K322012	D261
HVRK420001	E64	K053111C109, C110, C111		K135904553	C103	K322013	D261
HVRK440001	E64	K053112C109, C110, C111		K142230D248, D249, D272		K323027	C112
JJDX10-A.....D225		K053113C109, C110, C111		K142231	D248, D272	K343002	C101, C102
JJDX15-A.....D225		K053114C109, C110, C111		K142270	D248, D272	K352 366	C102
JJDX20-A.....D225		K053115C109, C110, C111		K152003C101, C102, D261		K352056	C112
JJDX25-A.....D225		K053116C109, C110, C111		K162001	D261	K352073	C111
JJDX30-A.....D225		K053143	C112	K175803553	D260	K352074	C111
JJDX35	D225	K053144	C112	K175903553	D260	K352075	C111
K012003	C109, C110	K053145	C112	K183108	C101	K352076	C107, C108
K013001	C103	K053146	C112	K183047	C101	K352077	C107, C108
K022090	D248	K053147	C112	K183049	C107, C108, C111, C112	K352078	C109
K022091	D248	K053157	C108, C112	K183057	C107, C108, C111, C112	K352080	C110
K022095	D249, D251	K053159	C112	K183058	C109, C110, C111, C112	K352083	C112
K022101	D248	K053218	C107, C111	K183077	D259	K352124	D261
K0251035	D260	K053219	C108, C112	K183082	D259	K352125	D261
K0252035	D260	K053220	C107, C111	K183083	D259	K352126	D261
K0253035	D260	K053221	C108, C112	K183084	D259	K352127	D261
K032270	D259	K06020003	D261	K183088	D259	K352128	D261
K043011	D259	K062005	C103	K185802553	D260	K352129	D261
K043012	D259	K0653035	D260	K185902553	D260	K352130	D261
K0451025	C102	K0655035	D260	K202001	C107, C108, C111, C112	K352131	D261
K0452025	D260	K0656035	D260	K202002	C107, C108, C111, C112	K352276	C107, C108
K0453025	D260	K0658035	D260	K212001	C107, C108, C111, C112	K352277	C107, C108
K053010	C112	K0659035	D260	K212002	C107, C108, C111, C112	K352355	D261
K053011	C112	K0853025	D260	K212001	C107, C108, C111, C112	K352359	D261
K053018	C108	K0855025	D260	K212002	C107, C108, C111, C112	K352360	D261
K053019	C108	K0856025	D260	K21R02012L.....D261		K352362	D261
K053022	C107, C111	K0858025	D260	K21R02025L.....D261, E29		K362307	D259
		K0859025	D260			K362308	D259
		K092020	C107, C108, C111, C112			K41RB72009	C102
		K092034	C107, C108, C111, C112				

Part Number Index
Safety Guide
Offer of Sale
Part Number Index, Safety Guide, Offer of Sale



For inventory, lead times, and kit lookup, visit www.pdnplu.com

Model No.	Section / Page No.	Model No.	Section / Page No.	Model No.	Section / Page No.	Model No.	Section / Page No.
K41RB72011	C102	K593041 ...C101, C102, C104		L66481221	D249	L6858810253.....	D251
K41RB72121	C107, C108, C111, C112	K593060	D260	L66481231.....	D249	L6858910249.....	D251
K41RB72143	C109, C110, C111, C112	K593071	D260	L6653821149.....	D248	L6858910253.....	D251
K41RB72210	C108	K593081	D260	L6653821153.....	D248	L69441211.....	D250
K41RB72211	C108	K593094	C104	L6653822149.....	D248	L69441221.....	D250
K41RB72221	C107, C108, C111, C112	K593097	C104	L6653822153.....	D248	L69441231.....	D250
K423002	C102	K593098	C104	L6653823149.....	D248	L69481211.....	D251
K423010	C101	K593108	C103, C104	L6653823153.....	D248	L69481221.....	D251
K423022	C103	K593111	C104	L6653921149.....	D248	L69481231.....	D251
K4520N14060.....	D258	K593112	C103	L6653921153.....	D248	L6954821149.....	D250
K4520N14160.....	D258	K593125	D260	L6653922149.....	D248	L6954821153.....	D250
K4520N14300.....	D258	K593185	C104	L6653922153.....	D248	L6954822149.....	D250
K472001C.....	D259	K593254	C104	L6653923149.....	D248	L6954822153.....	D250
K472002C.....	D259	K593271	C104	L6653923153.....	D248	L6954823149.....	D250
K472003C.....	D259	K593274	D260	L6658821149.....	D249	L6954823153.....	D250
K472009C.....	D259	L55402308C	D255	L6658821153.....	D249	L6954921149.....	D250
K473011	C103	L55403308C	D255	L6658822149.....	D249	L6954921153.....	D250
K473014	C107, C108, C111, C112	L55405305C	D257	L6658822153.....	D249	L6954922149.....	D250
K473015	C107, C108, C111, C112	L55405307C	D256	L6658823149.....	D249	L6954922153.....	D250
K473016	C109, C110, C111, C112	L55406307C	D256	L6658823153.....	D249	L6954923149.....	D250
K493002	C107, C108, C111, C112	L55407305C	D256	L6658921149.....	D249	L6954923153.....	D250
K493009	C107, C108, C111, C112	L55407306C	D256	L6658921153.....	D249	L6958821149.....	D251
K493016	C109, C110, C111, C112	L55407314C	D256	L6658922149.....	D249	L6958821153.....	D251
K563015	C107	L55408302C	D255	L6658922153.....	D249	L6958822149.....	D251
K563016	C108, C112	L55408303C	D255	L6658923149.....	D249	L6958822153.....	D251
K563017	C107	L55408311C	D255	L6658923153.....	D249	L6958823149.....	D251
K563021	C108, C112	L55411308C	D255	L67431102.....	D248	L6958823153.....	D251
K563027	C112	L55414307C	D256	L67481102.....	D249	L6958921149.....	D251
K593003	C104	L55414314C	D257	L6753810249.....	D248	L6958921153.....	D251
K593007	C104	L65431102.....	D248	L6753810253.....	D248	L6958922149.....	D251
K593010C101, C102, C104		L65481102.....	D249	L6753910249.....	D248	L6958922153.....	D251
K593014	C101, C102, C104, D260	L6553810249.....	D248	L6753910253.....	D248	L6958923149.....	D251
K593025C101, C102, C104		L6553810253.....	D248	L6758810249.....	D249	L6958923153.....	D251
K593025	D260	L6553910249.....	D248	L6758810253.....	D249	L70441102.....	D250
K593035	C101, C102, C104, D260	L6553910253.....	D248	L6758910249.....	D249	L70481102.....	D251
		L6558810249.....	D249	L6758910253.....	D249	L7054810249.....	D250
		L6558810253.....	D249	L68441102.....	D250	L7054810253.....	D250
		L6558910249.....	D249	L68481102.....	D251	L7054910249.....	D250
		L66431211.....	D248	L6854810249.....	D250	L7054910253.....	D250
		L66431221.....	D248	L6854810253.....	D250	L7058810249.....	D251
		L66431231.....	D248	L6854910249.....	D250	L7058810253.....	D251
		L66481211.....	D249	L6854910253.....	D250	L7058910249.....	D251
				L6858810249.....	D251	L7058910253.....	D251

Part Number Index

Safety Guide

Offer of Sale

Part Number Index, Safety Guide, Offer of Sale



For inventory, lead time, and kit lookup, visit www.pdnplu.com

Model No.	Section / Page No.	Model No.	Section / Page No.	Model No.	Section / Page No.	Model No.	Section / Page No.
LV2N2BSS	E53	M03321833	E26	M05865451	E25	M06444651	E25
LV2N3B	E53	M03324633	E26	M062*03	E30	M06444659	E25
LV3N3B	E53	M03331833	E26	M062*05	E31	M06461851	E25
LV3N4BSS	E53	M03334633	E26	M062*19	E32	M06461859	E25
LV3N6B	E53	M03341833	E26	M062*26	E32	M06464651	E25
LV4N4BSS	E53	M03344633	E26	M062*30	E33	M06464659	E25
LV4N6B	E53	M053003	E29	M062*33	E33	M06521851	E25
LV6N6B	E53	M053007	E29	M062*40	E30	M06521859	E25
LV6N8BSS	E53	M053019	E29	M062*43	E30	M06524651	E25
LV6NAB	E53	M053020	E29	M062*48	E31	M06524659	E25
LV8N8BSS	E53	M053030	E29	M062*51	E31	M06531851	E25
LV8NAB	E53	M053033	E29	M062*54	E35	M06531859	E25
LVANAB	E53	M053038	E29	M062*59	E31	M06534651	E25
LVBNCB	E53	M053039	E29	M062*62	E34	M06534659	E25
LVBNCBSS	E53	M05422443	E25	M062*63	E34	M06541851	E25
LVCNCB	E53	M05422448	E25	M062*64	E34	M06541859	E25
LVCNCBSS	E53	M05422488	E26	M062*65	E34	M06544651	E25
M012001	E35	M05425443	E25	M062*74	E34	M06544659	E25
M012002	E35	M05425448	E25	M062*78	E34	M06561851	E25
M012003	E35	M05425488	E26	M062*84	E35	M06561859	E25
M012005	E35	M05432443	E25	M062*85	E35	M06564651	E25
M013005	E32	M05432448	E25	M062*88	E30	M06564659	E25
M013007	E32	M05432488	E26	M062*95	E34	M073006	E35
M013009	E32	M05435443	E25	M062*96	E34	M073009	E30
M013011	E31	M05435448	E25	M062*97	E34	M073016	E31, E32, E34, E35
M013012	E31	M05435488	E26	M062*98	E34	M073017	E35
M013013	E31	M05442443	E25	M062*99	E31	M073022	E30
M013014	E31	M05442448	E25	M06221840	E26	M073026	E31, E32, E34, E35
M013015	E31	M05442488	E26	M06224640	E26	M073028	E35
M013016	E31	M05445443	E25	M06231840	E26	M073033	E30
M013017	E31	M05445448	E25	M06234640	E26	M073037	E31, E32, E34, E35
M01921819	E26	M05445488	E26	M06241840	E26	M073042	E30
M01924619	E26	M05462443	E25	M06244640	E26	M073046	E31, E32, E34, E35
M01931819	E26	M05462448	E25	M06421851	E25	M083003	E34
M01934619	E26	M05465443	E25	M06421859	E25	M083004	E34
M01941819	E26	M05465448	E25	M06424651	E25	M083005	E34
M01944619	E26	M05822451	E25	M06424659	E25	M083008	E34
M01961819	E26	M05825451	E25	M06431851	E25	M08421830	E26
M01964619	E26	M05832451	E25	M06431859	E25	M08424630	E26
M032*18	E29	M05835451	E25	M06434651	E25	M08431830	E26
M032*24	E29	M05842451	E25	M06434659	E25		
M032*46	E29	M05845451	E25	M06441851	E25		
M032*54	E29	M05862451	E25	M06441859	E25		

Part Number Index
Safety Guide
Offer of Sale
Part Number Index, Safety Guide, Offer of Sale



For inventory, lead times, and kit lookup, visit www.pdnplu.com

Model No.	Section / Page No.	Model No.	Section / Page No.	Model No.	Section / Page No.	Model No.	Section / Page No.
M08434630.....	E26	M08561851.....	E25	M09661843.....	E25	M232001.....	E28
M08441830.....	E26	M08564605.....	E26	M09664605.....	E26	M232002.....	E28
M08444630.....	E26	M08564626.....	E26	M09664643.....	E25	M232003.....	E28
M08521805.....	E26	M08564643.....	E25	M09721848.....	E25	M232004.....	E28
M08521826.....	E26	M08564648.....	E25	M09724648.....	E25	M232005.....	E28
M08521843.....	E25	M08564651.....	E25	M09731848.....	E25	M232006.....	E28
M08521848.....	E25	M09521803.....	E26	M09734648.....	E25	M242001.....	E29
M08521851.....	E25	M09521805.....	E26	M09741848.....	E25	M242002.....	E29
M08521888.....	E26	M09521843.....	E25	M09744648.....	E25	M242003.....	E29
M08524605.....	E26	M09524603.....	E26	M09761848.....	E25	M242004.....	E29
M08524626.....	E26	M09524605.....	E26	M09764648.....	E25	M242006.....	E29
M08524643.....	E25	M09524643.....	E25	M09821848.....	E25	M242007.....	E29
M08524648.....	E25	M09531803.....	E26	M09824648.....	E25	M242008.....	E29
M08524651.....	E25	M09531805.....	E26	M09831848.....	E25	M242009.....	E29
M08524688.....	E26	M09531843.....	E25	M09834648.....	E25	M242011.....	E29
M08531805.....	E26	M09534603.....	E26	M09841848.....	E25	M242012.....	E29
M08531826.....	E26	M09534605.....	E26	M09844648.....	E25	M242013.....	E29
M08531843.....	E25	M09534643.....	E25	M09861848.....	E25	M242014.....	E29
M08531848.....	E25	M09541803.....	E26	M09864648.....	E25	M243008.....	E34
M08531851.....	E25	M09541805.....	E26	M103012.....	E30, E31, E33, E35	M243019.....	E34
M08531888.....	E26	M09541843.....	E25	M103047.....	E30, E31, E33, E35	M243027.....	E34
M08534605.....	E26	M09544603.....	E26	M103066.....	E30, E31, E33, E35	M243028.....	E32
M08534626.....	E26	M09544605.....	E26	M103108.....	E30, E31, E33, E35	M243032.....	E34
M08534643.....	E25	M09544643.....	E25	M103111.....	E34, E35	M243036.....	E32
M08534648.....	E25	M09561803.....	E26	M103112.....	E34, E35	M243043.....	E34
M08534651.....	E25	M09561805.....	E26	M103113.....	E34, E35	M243044.....	E34
M08534688.....	E26	M09561843.....	E25	M103114.....	E34, E35	M243045.....	E34
M08541805.....	E26	M09564603.....	E26	M122001.....	E29	M273002.....	E30
M08541826.....	E26	M09564605.....	E26	M122002.....	E29	M273006.....	E30
M08541843.....	E25	M09564643.....	E25	M122003.....	E29	M273007.....	E30
M08541848.....	E25	M09621805.....	E26	M122004.....	E29	M273022.....	E30
M08541851.....	E25	M09621843.....	E25	M122005.....	E29	M273023.....	E30
M08541888.....	E26	M09624605.....	E26	M122006.....	E29	M273024.....	E30
M08544605.....	E26	M09624643.....	E25	M133003.....	E30, E31	M303005.....	E31
M08544626.....	E26	M09631805.....	E26	M133012.....	E30, E31	M303006.....	E31
M08544643.....	E25	M09631843.....	E25	M133018.....	E30, E31	M303007.....	E31
M08544648.....	E25	M09634605.....	E26	M163005.....	E33	M303008.....	E31
M08544651.....	E25	M09634643.....	E25	M163012.....	E33	M313004.....	E29
M08544688.....	E26	M09641805.....	E26	M193002.....	E33	M313011.....	E29
M08561805.....	E26	M09641843.....	E25	M193005.....	E33	M313013.....	E29
M08561826.....	E26	M09644605.....	E26			M313017.....	E29
M08561843.....	E25	M09644643.....	E25			M323005.....	E30
M08561848.....	E25	M09661805.....	E26			M323006.....	E30

Part Number Index

Safety Guide

Offer of Sale

Part Number Index, Safety Guide, Offer of Sale



For inventory, lead time, and kit lookup, visit www.pdnplu.com

Model No.	Section / Page No.	Model No.	Section / Page No.	Model No.	Section / Page No.	Model No.	Section / Page No.
M323007.....	E30	M493007.....	E34	MMDVA2.....	D34, D38, D42, D56	N3555904553.....	C97
M333013.....	E30, E31	M493008.....	E34	MMFS##A05FM5.....	C85	N3556904549.....	C97
M333014.....	E30	M493009.....	E33	MMFS##A12FF1.....	C85	N3556904553.....	C97
M333016.....	E30	M493010.....	E33	MMFS6A00M3.....	C87	N3557904549.....	C97
M343018.....	E32	M493011.....	E34	MMFU##A05F.....	C85	N3557904553.....	C97
M343019.....	E32	M493012.....	E34	MMFU##A12F.....	C85	N36471091.....	C100
M343022.....	E32	M493014.....	E34	MMFU**A**F.....	C85	N36481091.....	C100
M343027.....	E32	M493015.....	E32	N1641001.....	F15	N36491091.....	C100
M343028.....	E32	M493020.....	E32	N1642003.....	F15	N3657904753.....	C99
M343032.....	E33	M493022.....	E33	N1643003.....	F15	N3658904753.....	C99
M343038.....	E33	M493023.....	E33	N220-1900J.....	C89	N3659904753.....	C99
M343039.....	E33	M493024.....	E33	N31431091.....	C100	N37431091.....	C100
M363002.....	E32	M493026.....	E34	N31441091.....	C100	N37441091.....	C100
M373014.....	E29	M493027.....	E34	N31451091.....	C100	N37451091.....	C100
M373020.....	E29	M493037.....	E34	N31461091.....	C100	N37461091.....	C100
M373033.....	E29	M493038.....	E34	N31471091.....	C100	N37471091.....	C100
M373039.....	E29	M523009.....	E34	N3153904549.....	C97	N3753904549.....	C97
M373060.....	E29	M523010.....	E34	N3153904553.....	C97	N3753904553.....	C97
M373064.....	E29	M523011.....	E34	N3154904549.....	C97	N3754904549.....	C97
M373074.....	E29	M553004.....	E30	N3154904553.....	C97	N3754904553.....	C97
M373076.....	E29	M553005.....	E30	N3155904549.....	C97	N3755904549.....	C97
M373102.....	E29	M563002.....	E34, E35	N3155904553.....	C97	N3755904553.....	C97
M373103.....	E29	M563006.....	E34, E35	N3156904549.....	C97	N3756904549.....	C97
M373116.....	E29	M563007.....	E34	N3156904553.....	C97	N3756904553.....	C97
M373118.....	E29	M563008.....	E34	N3156904553.....	C97	N3757904549.....	C97
M373142.....	E29	M563009.....	E34	N3157904549.....	C97	N3757904553.....	C97
M373146.....	E29	M563014.....	E34, E35	N3157904553.....	C97	N38471091.....	C100
M373156.....	E29	M563016.....	E34	N32471091.....	C100	N38481091.....	C100
M383007.....	E32	M573001.....	E33	N32481091.....	C100	N38491091.....	C100
M383011.....	E32	M573003.....	E33	N32491091.....	C100	N3857904753.....	C99
M383018.....	E32	M573004.....	E33	N3257904753.....	C99	N3858904753.....	C99
M383029.....	E32	M573011.....	E33	N3258904753.....	C99	N3859904753.....	C99
M383032.....	E34	MCS10A05PDL.....	C86	N3259904753.....	C99	P01698.....	D258
M383033.....	E34	MFSA05DB.....	C89	N35431091.....	C100	P04062.....	D258
M383034.....	E34	MFSA12DB.....	C89	N35441091.....	C100	P04063.....	D258
M413015.....	E34	MFUA05DB.....	C89	N35451091.....	C100	P0566202.....	D12
M413016.....	E34	MFUA12DB.....	C89	N35461091.....	C100	P0568800.....	D9
M413017.....	E34	MMCS##A05FM5.....	C85	N35471091.....	C100	P2D2W3226C5.....	D61
M423002.....	E33	MMCS##A12FF1.....	C85	N3553904549.....	C97	P2D8V32C5.....	D61
M423004.....	E33	MMCU##A05F.....	C85	N3553904553.....	C97	P2FA22-15.....	C26
M443002.....	E30	MMCU##A12F.....	C85	N3554904549.....	C97	P2FCA442.....	D128, D227
M443003.....	E30	MMDVA1.....	D34, D38, D42, D56	N3554904553.....	C97	P2FCA445.....	D128, D227
M493006.....	E34			N3555904549.....	C97	P2FCA449.....	D128, D227

Part Number Index
 Safety Guide
 Offer of Sale
 Part Number Index, Safety Guide, Offer of Sale



For inventory, lead times, and kit lookup, visit www.pdnplu.com

Model No.	Section / Page No.	Model No.	Section / Page No.	Model No.	Section / Page No.	Model No.	Section / Page No.
P2FCA453.....	D128, D227	P2LAX61111	E15	P2LAZ611EENDBB49	C3	P2LBX592EENDDG53	C14
P2FCA457.....	D128, D227	P2LAX61122	E15	P2LAZ611EENDBB53	C3	P2LBX592EENXB549.....	C14
P2FCB449	C6	P2LAX69111	E15	P2LAZ691EENDBB49	C3	P2LBX592EENXB553.....	C14
P2FCB453	C6	P2LAX69122	E15	P2LAZ691EENDBB53	C3	P2LBX592ESHDDDB47	C16
P2FP13N4C	C57	P2LAX691EENDD7B9	C15	P2LAZ711EENDBB49	C4	P2LBX592ESHDDDB48.....	C16
P2FP13N4D	C57, C59	P2LAX691EENXB549.....	C15	P2LAZ711EENDBB53	C4	P2LBX592ESHDDG47	C16
P2FS13N1AE49	C51	P2LAX691EENXB553.....	C15	P2LAZ791EENDBB49	C4	P2LBX592ESHDDG48	C16
P2LAX311VS.....	E15	P2LAX691PP	C19	P2LAZ791EENDBB53	C4	P2LBX592ESNDD7B9.....	C13
P2LAX311W.....	E15	P2LAX81111	E15	P2LAZ811EENDBB49	C4	P2LBX592ESNDDDB49.....	C13
P2LAX391ESHDDDB48.....	C16	P2LAX81122	E15	P2LAZ811EENDBB53	C4	P2LBX592ESNDDDB53.....	C13
P2LAX391ESHDDG48	C16	P2LAX89111	E15	P2LAZ891EENDBB49	C4	P2LBX592ESNDDG49	C13
P2LAX391ESNDD7B9.....	C12	P2LAX89122	E15	P2LAZ891EENDBB53	C4	P2LBX592ESNDDG53	C13
P2LAX391ESNDDDB53.....	C12	P2LAX891EENDD7B9	C15	P2LBX312JJ	E16	P2LBX592ESNXB549	C13
P2LAX391ESNDDG53	C12	P2LAX891EENXB549.....	C15	P2LBX312VS	E15	P2LBX592ESNXB553	C13
P2LAX391ESNXB549.....	C12	P2LAX891EENXB553.....	C15	P2LBX312VV.....	E15	P2LBX592JJ	E16
P2LAX391ESNXB553.....	C12	P2LAXGAXG##NP.....	C21	P2LBX392ESHDDDB47	C16	P2LBX592PP	C19
P2LAX391PS	C19	P2LAXGAXN##NP.....	C21	P2LBX392ESHDDDB48.....	C16	P2LBX592PS	C19
P2LAX391VS.....	E15	P2LAXK20P	C21	P2LBX392ESHDDG47	C16	P2LBX592VS	E15
P2LAX391W.....	E15	P2LAXK84P	C21	P2LBX392ESHDDG48	C16	P2LBX592VV.....	E15
P2LAX511VS.....	E15	P2LAXK87P	C21	P2LBX392ESNDD7B9.....	C12	P2LBX592ZS.....	E16
P2LAX511W.....	E15	P2LAXMAXG##NP	C21	P2LBX392ESNDDDB49.....	C12	P2LBX592ZZ.....	E16
P2LAX591EEHDDDB47	C17	P2LAXMAXN##NP	C21	P2LBX392ESNDDDB53.....	C12	P2LBX61211	E15
P2LAX591EEHDDDB48.....	C17	P2LAXSK1	C31	P2LBX392ESNDDG49	C12	P2LBX61222	E15
P2LAX591EEHDDG48.....	C17	P2LAXSK2	C31	P2LBX392ESNDDG53	C12	P2LBX692PP	C19
P2LAX591EENDD7B9.....	C14	P2LAZ311EENDBB49	C3	P2LBX392ESNXB549	C12	P2LBX69211	E15
P2LAX591EENDDDB49.....	C14	P2LAZ311EENDBB53	C3	P2LBX392ESNXB553	C12	P2LBX69222	E15
P2LAX591EENDDDB53.....	C14	P2LAZ311ESNDBB49.....	C3	P2LBX392JJ	E16	P2LBX692EEHDDDB47	C17
P2LAX591EENDDG53.....	C14	P2LAZ311ESNDBB53.....	C3	P2LBX392PS	C19	P2LBX692EEHDDDB48.....	C17
P2LAX591EENXB549.....	C14	P2LAZ391EENDBB49	C3	P2LBX392VS	E15	P2LBX692EEHDDG47	C17
P2LAX591EENXB553.....	C14	P2LAZ391EENDBB53.....	C3	P2LBX392VV.....	E15	P2LBX692EEHDDG48	C17
P2LAX591ESHDDDB47	C16	P2LAZ391ESNDBB49.....	C3	P2LBX512JJ	E16	P2LBX692EENDD7B9.....	C15
P2LAX591ESHDDDB48.....	C16	P2LAZ391ESNDBB53.....	C3	P2LBX512VS	E15	P2LBX692EENDDDB49.....	C15
P2LAX591ESHDDG48	C16	P2LAZ391PS	C5	P2LBX512VV.....	E15	P2LBX692EENDDDB53.....	C15
P2LAX591ESNDD7B9.....	C13	P2LAZ511EENDBB49	C3	P2LBX512ZS.....	E16	P2LBX692EENDDG49	C15
P2LAX591ESNDDDB49.....	C13	P2LAZ511EENDBB53	C3	P2LBX512ZZ.....	E16	P2LBX692EENXB549.....	C15
P2LAX591ESNDDDB53.....	C13	P2LAZ511ESNDBB49.....	C3	P2LBX592EEHDDDB47	C17	P2LBX692EENXB553.....	C15
P2LAX591ESNDDG53	C13	P2LAZ511ESNDBB53.....	C3	P2LBX592EEHDDDB48.....	C17	P2LBX81211	E15
P2LAX591ESNXB549.....	C13	P2LAZ591EENDBB49	C3	P2LBX592EEHDDG47	C17	P2LBX81222	E15
P2LAX591ESNXB553.....	C13	P2LAZ591EENDBB53.....	C3	P2LBX592EEHDDG48	C17	P2LBX89211	E15
P2LAX591PP	C19	P2LAZ591ESNDBB49.....	C3	P2LBX592EEHDDG48	C17	P2LBX89222	E15
P2LAX591PS	C19	P2LAZ591ESNDBB53.....	C3	P2LBX592EENDD7B9.....	C14	P2LBX892EEHDDDB47	C17
P2LAX591VS.....	E15	P2LAZ591PP	C5	P2LBX592EENDDDB49.....	C14	P2LBX892EEHDDDB48.....	C17
P2LAX591W.....	E15	P2LAZ591PS	C5	P2LBX592EENDDG49	C14	P2LBX892EEHDDG47	C17

Part Number Index

Safety Guide

Offer of Sale

Part Number Index, Safety Guide, Offer of Sale



For inventory, lead time, and kit lookup, visit www.pdnplu.com

Model No.	Section / Page No.	Model No.	Section / Page No.	Model No.	Section / Page No.	Model No.	Section / Page No.
P2LBX892EEHDDG48C17		P2LBZ792EENDBB53C4		P2LCX69311E15		P2LCZ593ESNDBB53C3	
P2LBX892EENDD7B9C15		P2LBZ812EENDBB49C4		P2LCX69322E15		P2LCZ593PPC5	
P2LBX892EENDDB49C15		P2LBZ812EENDBB53C4		P2LCX693EEHDDB47C17		P2LCZ593PSC5	
P2LBX892EENDDB53C15		P2LBZ892EENDBB49C4		P2LCX693EEHDDG47C17		P2LCZ613EENDBB49C3	
P2LBX892EENDDG49C15		P2LBZ892EENDBB53C4		P2LCX693EENDD7B9C15		P2LCZ613EENDBB53C3	
P2LBX892EENDDG53C15		P2LCX313VSE15		P2LCX693EENDDB49C15		P2LCZ693EENDBB49C3	
P2LBX892EENXB549C15		P2LCX313VVE15		P2LCX693EENDDG49C15		P2LCZ693EENDBB53C3	
P2LBX892EENXB553C15		P2LCX393ESHDDDB48C16		P2LCX693EENXB549C15		P2LCZ713EENDBB49C4	
P2LBX892PPC19		P2LCX393ESHDDG48C16		P2LCX693EENXB553C15		P2LCZ713EENDBB53C4	
P2LBXGAXG##NPC21		P2LCX393ESNDD7B9C12		P2LCX693PPC19		P2LCZ793EENDBB49C4	
P2LBXGAXN##NPC21		P2LCX393ESNDDB53C12		P2LCX81311E15		P2LCZ793EENDCB53C4	
P2LBXK20PC21		P2LCX393ESNDDG53C12		P2LCX81322E15		P2LCZ813EENDBB49C4	
P2LBXK84PC21		P2LCX393ESNXB549C12		P2LCX89311E15		P2LCZ813EENDBB53C4	
P2LBXK87PC21		P2LCX393ESNXB553C12		P2LCX89322E15		P2LCZ893EENDBB49C4	
P2LBXMAXG##NPC21		P2LCX393PSC19		P2LCX893EEHDDB47C17		P2LCZ893EENDBB53C4	
P2LBXMAXN##NPC21		P2LCX393VSE15		P2LCX893EEHDDG47C17		P2LDX314VSE15	
P2LBXSK1C31		P2LCX393VVE15		P2LCX893EENDD7B9C15		P2LDX314VVE15	
P2LBZ312EENDBB49C3		P2LCX513VSE15		P2LCX893EENDDB49C15		P2LDX394ESNDD7B9C12	
P2LBZ312EENDBB53C3		P2LCX513VVE15		P2LCX893EENDDG49C15		P2LDX394ESNXB549C12	
P2LBZ312ESNDBB49C3		P2LCX593EEHDDB47C17		P2LCX893EENXB549C15		P2LDX394ESNXB553C12	
P2LBZ312ESNDBB53C3		P2LCX593EEHDDG48C17		P2LCX893EENXB553C15		P2LDX394PSC19	
P2LBZ392EENDBB49C3		P2LCX593EEHDDG48C17		P2LCX893PPC19		P2LDX394VSE15	
P2LBZ392EENDBB53C3		P2LCX593EENDD7B9C14		P2LCXDXSK1C31		P2LDX394VVE15	
P2LBZ392ESNDBB49C3		P2LCX593EENDDB49C14		P2LCXK20PC21		P2LDX514VSE15	
P2LBZ392ESNDBB53C3		P2LCX593EENDDB53C14		P2LCXK87PC21		P2LDX514VVE15	
P2LBZ392PSC5		P2LCX593EENDDG53C14		P2LCXMAXG##NPC21		P2LDX594EEHDDB47C17	
P2LBZ512EENDBB49C3		P2LCX593EENXB549C14		P2LCXMAXN##NPC21		P2LDX594EEHDDB48C17	
P2LBZ512EENDBB53C3		P2LCX593EENXB553C14		P2LCZ313EENDBB49C3		P2LDX594EENDD7B9C14	
P2LBZ512ESNDBB49C3		P2LCX593ESHDDB47C16		P2LCZ313EENDBB53C3		P2LDX594EENDDB49C14	
P2LBZ512ESNDBB53C3		P2LCX593ESHDDB48C16		P2LCZ313ESNDBB49C3		P2LDX594EENDDB53C14	
P2LBZ592EENDBB49C3		P2LCX593ESHDDG48C16		P2LCZ313ESNDBB53C3		P2LDX594EENXB549C14	
P2LBZ592EENDBB53C3		P2LCX593ESNDD7B9C13		P2LCZ393EENDBB49C3		P2LDX594EENXB553C14	
P2LBZ592ESNDBB49C3		P2LCX593ESNDDB49C13		P2LCZ393EENDBB53C3		P2LDX594ESHDDB47C16	
P2LBZ592ESNDBB53C3		P2LCX593ESNDDB53C13		P2LCZ393ESNDBB49C3		P2LDX594ESHDDB48C16	
P2LBZ592PPC5		P2LCX593ESNDDG53C13		P2LCZ393ESNDBB53C3		P2LDX594ESNDD7B9C13	
P2LBZ592PSC5		P2LCX593ESNXB549C13		P2LCZ393PSC5		P2LDX594ESNDDB49C13	
P2LBZ612EENDBB49C3		P2LCX593ESNXB553C13		P2LCZ513EENDBB49C3		P2LDX594ESNDDB53C13	
P2LBZ612EENDBB53C3		P2LCX593PPC19		P2LCZ513EENDBB53C3		P2LDX594ESNXB549C13	
P2LBZ692EENDBB49C3		P2LCX593PSC19		P2LCZ513ESNDBB49C3		P2LDX594ESNXB553C13	
P2LBZ692EENDBB53C3		P2LCX593VSE15		P2LCZ513ESNDBB53C3		P2LDX594PPC19	
P2LBZ712EENDBB49C4		P2LCX593VVE15		P2LCZ593EENDBB49C3		P2LDX594PSC19	
P2LBZ712EENDBB53C4		P2LCX61311E15		P2LCZ593EENDBB53C3		P2LDX594VSE15	
P2LBZ792EENDBB49C4		P2LCX61322E15		P2LCZ593ESNDBB49C3		P2LDX594VVE15	

Part Number Index
Safety Guide
Offer of Sale
Part Number Index, Safety Guide, Offer of Sale



For inventory, lead times, and kit lookup, visit www.pdnplu.com

Model No.	Section / Page No.	Model No.	Section / Page No.	Model No.	Section / Page No.	Model No.	Section / Page No.
P2LDX61411	E15	P2M1S4ES2CW	D33	P2M1X3ES	D61	P2M2PXST	D56
P2LDX61422	E15	P2M1S4PP	D33	P2M1X4EE	D61	P2M2S3ES2C	D33
P2LDX69411	E15	P2M1S4PS	D33	P2M1X4ES	D61	P2M2S3ES2CW	D33
P2LDX69422	E15	P2M1SCEE2C	D33	P2M1XCEE	D61	P2M2S3PS	D33
P2LDX694EEHDDDB47	C17	P2M1SCEE2CW	D33	P2M1XDEE	D61	P2M2S4EE2C	D33
P2LDX694EEHDDG47	C17	P2M1SCPP	D33	P2M1XEEE	D61	P2M2S4ES2C	D33
P2LDX694EENDD7B9	C15	P2M1SDEE2C	D33	P2M1XJEE	D61	P2M2S4ES2CW	D33
P2LDX694EENDDB49	C15	P2M1SDEE2CW	D33	P2M2BXT0A	D37	P2M2S4PP	D33
P2LDX694EENDDG49	C15	P2M1SDPP	D33	P2M2BXV0A	D43	P2M2S4PS	D33
P2LDX694EENXB549	C15	P2M1SEEE2C	D33	P2M2HBVA1080	D10	P2M2SCEE2C	D33
P2LDX694EENXB553	C15	P2M1SEEE2CW	D33	P2M2HBVA10800	D10, D43, D52, D140	P2M2SCEE2CW	D33
P2LDX694PP	C19	P2M1SGEE2C	D33	P2M2HBVA10808A	D10, D43, D52, D140	P2M2SCPP	D33
P2LDX81411	E15	P2M1SGEE2CW	D33	P2M2HBVA10808B	D10, D43, D52, D140	P2M2SDEE2C	D33
P2LDX81422	E15	P2M1T3ES2C	D37	P2M2HBVA20600	D10, D43, D52, D140	P2M2SDEE2CW	D33
P2LDX89411	E15	P2M1T3ES2CW	D37	P2M2HBVA20608A	D10, D43, D52, D140	P2M2SDPP	D33
P2LDX89422	E15	P2M1T3PS	D37	P2M2HBVA20608B	D10, D43, D52, D140	P2M2SEEE2C	D33
P2LDX894EEHDDDB47	C17	P2M1T4EE2C	D37	P2M2HBVC21600	D10, D43, D49, D139	P2M2SEEE2CW	D33
P2LDX894EEHDDG47	C17	P2M1T4EE2CW	D37	P2M2HBVD21600	D10, D43, D49, D139	P2M2SGEE2C	D33
P2LDX894EENDD7B9	C15	P2M1T4ES2C	D37	P2M2HBVP11600	D139	P2M2SGEE2CW	D33
P2LDX894EENDDDB49	C15	P2M1T4ES2CW	D37	P2M2HBVP21600	D10, D43, D49, D139	P2M2T3ES2C	D37
P2LDX894EENDDG49	C15	P2M1T4PP	D37	P2M2HBVS11600	D10, D43, D49, D139	P2M2T3ES2CW	D37
P2LDX894EENXB549	C15	P2M1T4PS	D37	P2M2HEV0A	D43	P2M2T3PS	D37
P2LDX894EENXB553	C15	P2M1TCEE2C	D37	P2M2HEV0D	D43	P2M2T4EE2C	D37
P2LDX894PP	C19	P2M1TCEE2CW	D37	P2M2HXT01	D37, D43	P2M2T4EE2CW	D37
P2M1K0GL	D56	P2M1TCPP	D37	P2M2HXT0T	D37, D43	P2M2T4ES2C	D37
P2M1K0GN	D56	P2M1TDEE2C	D37	P2M2K0CA	D61	P2M2T4ES2CW	D37
P2M1K0GT	D56	P2M1TDEE2CW	D37	P2M2K0FA	D61	P2M2T4PP	D37
P2M1K0TASD	D38, D42	P2M1TDPP	D37	P2M2K0JA	D61	P2M2T4PS	D37
P2M1PXCA	D57	P2M1TEEE2C	D37	P2M2K0PA	D61	P2M2TCEE2C	D37
P2M1PXFA	D57	P2M1TEEE2CW	D37	P2M2PXCA	D57	P2M2TCEE2CW	D37
P2M1PXSG	D56	P2M1TGEE2C	D37	P2M2PXFA	D57	P2M2TCPP	D37
P2M1PXSL	D56	P2M1TGEE2CW	D37	P2M2PXSG	D56	P2M2TDEE2C	D37
P2M1PXSM	D56	P2M1TJEE2C	D37	P2M2PXSL	D56	P2M2TDEE2CW	D37
P2M1PXSN	D56	P2M1TJEE2CW	D37	P2M2PXSM	D56	P2M2TDPP	D37
P2M1PXSR	D56	P2M1TJPP	D37	P2M2PXSN	D56	P2M2TEEE2C	D37
P2M1PXST	D56	P2M1V3ES2CV	D41	P2M2PXSR	D56	P2M2TGEE2C	D37
P2M1PXVA	D59	P2M1V4EE2CV	D41			P2M2TGEE2CW	D37
P2M1S3ES2C	D33	P2M1V4ES2CV	D41, D45			P2M2V3ES2CV	D41
P2M1S3ES2CW	D33	P2M1VCEE2CV	D41			P2M2V4EE2CV	D41
P2M1S3PS	D33	P2M1VDEE2CV	D41			P2M2V4ES2CV	D41
P2M1S4EE2C	D33	P2M1VEEE2CV	D41			P2M2V4ES2CV00F7	D45
P2M1S4EE2CW	D33	P2M1VGEE2CV	D41			P2M2VCEE2CV	D41
P2M1S4ES2C	D33	P2M1VJEE2CV	D41			P2M2VDEE2CV	D41

Part Number Index

Safety Guide

Offer of Sale

Part Number Index, Safety Guide, Offer of Sale



For inventory, lead time, and kit lookup, visit www.pdnplu.com

Model No.	Section / Page No.	Model No.	Section / Page No.	Model No.	Section / Page No.	Model No.	Section / Page No.
P2M2VEEE2CV	D41	P8LC221E.....	B6	PL1-1/4-70	D225, D240	PS243079BP	C6, C26, C52, D226
P2M2VGEE2CV.....	D41	P8LMH20M*A	D47	PL1-1/4-80	D225, D240	PS243083BP	C6, C26, C52, D226
P2M2X3ES	D61	P8LMH20M2A.....	D42	PL2-3/8-70	D225, D240	PS243087BP	C26, C52, D226
P2M2X4EE	D61	P8LMH20M5A.....	D42, D47	PL2-3/8-80	D225, D240	PS2430J79BP.....	C6, C26, C52, D226
P2M2X4ES	D61	P8LMH20M9A.....	D42, D47	PL2424P	E62	PS2430J83BP.....	C6, C26, C52, D226
P2M2XCEE	D61	P8LMH25M3A.....	D12, D42, D46, D125, D185	PL2425P	E62	PS2501P	C59
P2M2XDDEE	D61	P8LS08L226C.....	D34, D38	PL25	E62	PS2502P	C59
P2M2XEEE.....	D61	P8LS08L526C.....	D34, D38	PL3-1/2-70	D225, D240	PS2503P	C59
P2N-VK0P.....	D226	P8LS08L926C.....	D34, D38	PL3-1/2-80	D225, D240	PS2504P	C59
P2N-VM500AK.....	D225	P8LS12JACK	D10, D42, D52, D140	PL37	E62	PS2520P	C50
P2N-VM512MB....	D225, D246	P8LW021C.....	D34, D38	PL50	E62	PS2520P	C50
P2N-VM513ES.....	D225, D246	P8LW021C02.....	D34, D38	PLA25	E62	PS2569P	C50
P2N-VS512SD	D225, D240	P8LW021C04.....	D34, D38	PLA37	E62	PS257101P.....	C59
P2N-WK0P.....	D226	P8LW021C08.....	D34, D38	PLA50	E62	PS257102P.....	C59
P2N-WM513MB... ..	D225, D246	PD1-1/4-70	D225, D240	PLD25	E62	PS2584P	C59
P2N-WM514ES....	D225, D246	PD1-1/4-80	D225, D240	PLD37	E62	PS2587P	C59
P2N-WS513SD	D225, D240	PD2-3/8-70	D225, D240	PLD50	E62	PS2597**P	C59
P2N-YK0P.....	D226	PD2-3/8-80	D225, D240	PMDYY1	D38, D42, D56	PS2597GCP.....	C59
P2N-YM514MB....	D225, D246	PEJ01	D241	PMDYY2	D34, D38, D42, D56	PS2597NBP	C59
P2N-YM518ES.....	D225, D246	PEJ01-03-70.....	D212	PPRL15.....	E60, E61	PS2597NCP	C59
P2N-YS514SD	D225, D240	PEJ01-03-80.....	D212	PPS1-2C3-RHM.....	E56	PS2601P	C58
P66829	E62	PEJ02	D241	PPS1-2C3-RWL.....	E56	PS2602P	C50
P66837	E62	PEJ02-02-70.....	D211	PS1556	C6	PS2603P	C50
P6M-PAB1	D9, D10, D11	PEJ02-02-80.....	D211	PS2028BP	C26, C52	PS2604P	C50
P6M-PAB1	F12	PESC10	B6	PS2028BP	D128, D227	PS267101P.....	C58
P6M-PAB2	F12	PESC2001F	B6	PS2028JCP	C26, C52	PS267102P.....	C58
P6M-PAB3	D9, D10, D11	PESC2020B	B6	PS2028JCP	D128, D227	PS2684P	C58
P6M-PAB3	F12	PESC2220B	B6	PS203279BP	C26, C52	PS2801P	C57
P6M-PAB4	F12	PJL01	D241	PS203279BP	D128, D227	PS2802P	C57
P6M-PAB6	F12	PJLP01	D241	PS203283BP	C26, C52	PS2803P	C57
P6M-PAB8	F12	PJLP02	D241	PS203283BP	D128, D227	PS2804P	C57
P6M-PAC5	C28, C89	PJLP02-201-70....	D211, D212	PS2032J79CP	C52	PS2804VP	C57
P6M-PAC5	E17	PJLP02-201-80....	D211, D212	PS2032J79CP	D128, D227	PS2803VP	C57
P6M-PAC5	F12	PKG 3M-*-PSG 3M/S90.....	D184	PS2032J83CP	C52	PS2815P	C50
P8BPA00MA	D10, D42, D49, D140, D186	PKG 3M-4/S90	D184	PS2032J83CP	D128, D227	PS2817P	C50
P8BPA00MB	D10, D42, D49, D140, D185	PL01	D241	PS2038P	E22	PS2818P	C50
P8CS0803J.....	D34, D38	PL01-02-70.....	D102, D212	PS2039P	E22	PS2819P	C50
P8CS1204J.....	D34, D38	PL01-02-80.....	D102, D212	PS2041P	E22	PS2820P	C50
P8CS1205AA.....	D10, D42, D49, D140	PL02	D241	PS2043P	E21		
P8CS1205AB.....	D10	PL02-01-70.....	D211	PS2429BP	C6, C26, C52, D226		
P8L-C2	B6	PL02-01-80.....	D211	PS2429JBP.....	C6, C26, C52, D226		

Part Number Index
 Safety Guide
 Offer of Sale
 Part Number Index, Safety Guide, Offer of Sale



For inventory, lead times, and kit lookup, visit www.pdnplu.com

Model No.	Section / Page No.	Model No.	Section / Page No.	Model No.	Section / Page No.	Model No.	Section / Page No.
PS2828619P	D128, D227	PS294675BP	C26, C52	PS4002CP	D129	PS401166ACP	D85
PS2834P	C50	PS294679BP	B10	PS4003CP	D129	PS401166CCP	D85
PS2855P	D226	PS294679BP	C26, C52	PS4004CP	D129	PS401166JCP	D85
PS2866P	C50	PS294679BP	D227	PS4005DP	D129	PS401166MCP	D85
PS2867P	C50	PS294683BP	B10	PS4006DP	D129	PS4012P	D129
PS2868P	C50	PS294683BP	C26, C52	PS4007P	D129	PS4013P	D86, D110, D215
PS2869P	C50	PS294683BP	D227	PS4011	D134, D245	PS401500CP	D123, D226
PS2871P	C57	PS294687BP	B10	PS401110CCP	D91	PS401501CP	D123, D226
PS288*P	C57, C58	PS294687BP	C26, C52	PS401115	D95, D119, D219	PS4020L20DP	D86
PS2886P	C57	PS2946J75BP	B10	PS4011150DP	D109, D215	PS4020L21DP	D86
PS2887P	C57	PS2946J75BP	C26, C52	PS4011158FDP	D85	PS4020L30DP	D86
PS2892P	C6	PS2946J79BP	B10	PS401115ADP	D85	PS4020L31DP	D86
PS2893C##P	C52	PS2946J79BP	C26, C52	PS401115CDP	D85	PS4020L40DP	D86
PS2893CP	C52	PS2946J79BP	D227	PS401116	D95, D119, D219	PS4020L41DP	D86
PS2893D##P	C52	PS2946J83BP	B10	PS4011160DP	D109, D215	PS4020L60DP	D86
PS2893DP	C52	PS2946J83BP	C26, C52	PS4011168FDP	D85	PS4020L61DP	D86
PS2896P	C57	PS2946J83BP	D227	PS401116ADP	D85	PS4020M20DP	D86
PS2897GBP	C57	PS2966P	C50	PS401116CDP	D85	PS4020M21DP	D86
PS2897GCP	C57	PS2967P	C50	PS401155	D95, D119, D219	PS4020M40DP	D86
PS2897NBP	C57	PS2968P	C50	PS4011550DP	D109, D215	PS4020M41DP	D86
PS2897NCP	C57	PS2969P	C50	PS401155ACP	D85	PS4020T10DP	D86
PS290*CP	C56	PS2971CP	C56	PS401155CCP	D85	PS4020T11DP	D86
PS2902CP	C56	PS298*P	C56	PS401155JCP	D85	PS4020T20DP	D86
PS2903CP	C56	PS2981P	C56	PS401155MCP	D85	PS4020T21DP	D86
PS2904CP	C56	PS2982*##P	B10, C24, C51, C56, C57, C58, C59	PS401156	D95, D119, D219	PS4024P	D130
PS2915P	C50	PS2982B49P	D227	PS4011560CP	D215	PS402501	D220
PS2917P	C50	PS2982B53P	D227	PS401156ACP	D85	PS402601	D220
PS2918P	C50	PS2982C49P	D227	PS401156CC	D85	PS402701	D220
PS2919P	C50	PS2982C53P	D227	PS401156JCP	D85	PS402801	D220
PS2920P	C50	PS2986P	C56	PS401156MCP	D85	PS403000CP	D86, D110, D215
PS2921P	C50	PS2987P	C56	PS401160CP	D109	PS403001CP	D86, D110, D215
PS2930166P	C54	PS299*P	C56	PS401165	D95, D119, D219	PS403101	D119
PS2930233P	C54	PS2991P	C50	PS4011650CP	D109, D215	PS4031010CP	D109, D215
PS2932BP	B10	PS2994P	C50	PS4011658FCP	D85	PS4031010DP	D86
PS2932BP	C26, C52	PS2998P	C52	PS401165ACP	D85	PS4031011DP	D86, D109, D215
PS2932BP	D227	PS2999**P	C56	PS401165CCP	D85	PS4032CP	D86, D110, D226
PS2932HBP	B10	PS299922P	C56	PS401165JCP	D85	PS4033CP	D86, D89, D92, D110, D113, D116, D226
PS2932HBP	C26, C52	PS299933P	C56	PS401166	D95, D119, D219	PS4034CP	D86, D110, D226
PS2932JBP	B10	PS3202*##P	B10	PS4011660CP	D109, D215	PS4035CP	D86
PS2932JBP	C26, C52	PS3441*##P	B10	PS4011668FCP	D85		
PS2932JBP	D227	PS3541*##P	B10, C51, C56, C57, C58, C59				
PS2934P	C50	PS4001CP	D129				
PS294675BP	B10						

Part Number Index

Safety Guide

Offer of Sale

Part Number Index, Safety Guide, Offer of Sale



For inventory, lead time, and kit lookup, visit www.pdnplu.com

Model No.	Section / Page No.	Model No.	Section / Page No.	Model No.	Section / Page No.	Model No.	Section / Page No.
PS4036P	D130	PS411118 ...	D95, D119, D219	PS4120M21DP	D89	PS421110ACP	D91
PS4037	D136, D221	PS4111180CP	D113, D216	PS4120M40DP	D89	PS4211170CP	D217
PS4037166CP	D110, D215	PS411118ACP	D88	PS4120M41DP	D89	PS4211180CP	D116, D217
PS4037266CP	D110, D215	PS411118CCP	D88	PS4120T10DP	D89	PS421119	D95, D119, D219
PS4038	D98, D136	PS4111127	D219	PS4120T11DP	D89	PS4211190CP	D116
PS4038166CP	D86	PS4111128	D219	PS4120T20DP	D89	PS421119ACP	D91
PS4038266CP	D86	PS4111157 ...	D95, D119, D219	PS4120T21DP	D89	PS421119CCP	D91
PS4039P	D129	PS41111570CP	D113	PS413101	D119	PS421120	D219
PS4040P	D130	PS4111157ACP	D88	PS4131010DP	D89, D113, D216	PS421129	D219
PS404123P	D128	PS4111157CC	D88	PS4131011DP	D89, D113, D216	PS421150	D95, D119, D219
PS404142P	D128	PS4111157JCP	D88	PS4132CP	D89, D113, D226	PS4211500CP	D116
PS404145P	D128	PS4111157MCP	D88	PS4134CP	D89, D113, D226	PS421150ACP	D91
PS404157P	D128	PS4111158 ...	D95, D119, D219	PS4135CP	D89	PS421150CCP	D91
PS4041B9P	D128	PS41111580CP	D113	PS4136P	D130	PS421150JCP	D91
PS4042CP	D110, D226	PS4111158ACP	D88	PS4137	D136, D221	PS421150MCP	D91
PS4045BP	D130	PS4111158CC	D88	PS4137166CP	D113, D216	PS421159	D95, D119
PS4047BP	D130	PS4111158JCP	D88	PS4137266CP	D113, D216	PS4211590CP	D116
PS4048BP	D130	PS4111158MC	D88	PS4138	D98, D136	PS421159ACP	D91
PS4050030P	D130	PS4111167 ...	D95, D119, D219	PS4138166CP	D89	PS421159CCP	D91
PS4050060P	D130	PS41111670CP	D113, D216	PS4138266CP	D89	PS421159JCP	D91
PS4050125P	D130	PS4111167ACP	D88	PS4139P	D129	PS421159MCP	D91
PS4051060BP	D130	PS4111167CCP	D88	PS4140P	D130	PS421160	D95, D119, D219
PS4051160BP	C54	PS4111167JCP	D88	PS4142CP	D113, D226	PS4211600CP	D116, D217
PS4051160BP	D130	PS4111167MCP	D88	PS4145BP	D130	PS421160ACP	D91
PS4051P	D130	PS4111168 ...	D95, D119, D219	PS4147BP	D130	PS421160CCP	D91
PS4052160BP	D130	PS41111680CP	D113, D216	PS4148BP	D130	PS421160JDP	D91
PS4052CP	D129, D227	PS4111168ACP	D88	PS4150030BP	D130	PS421160MCP	D91
PS4053060BP	D130	PS4111168CCP	D88	PS4150060BP	D130	PS421169	D95, D119, D219
PS4053160BP	D130	PS4111168JCP	D88	PS4150125BP	D130	PS4211690CP	D116, D217
PS4053CP	D129, D227	PS4111168MCP	D88	PS4187DP	D129	PS421169ACP	D91
PS4087DP	D129	PS4112P	D129	PS41D3DP	D129	PS421169CCP	D91
PS40D3DP	D129	PS4113P	D89, D113, D216	PS41D5DP	D129	PS421169JDP	D91
PS4101CP	D129	PS411500CP	D123, D226	PS4201CP	D129	PS421169MCP	D91
PS4102CP	D129	PS411501CP	D123, D226	PS4202CP	D129	PS4212P	D129
PS4103CP	D129	PS4120L20DP	D89	PS4203CP	D129	PS4213P	D92, D116, D217
PS4104CP	D129	PS4120L21DP	D89	PS4204CP	D129	PS421500CP	D123, D226
PS4105DP	D129	PS4120L30DP	D89	PS4205DP	D129	PS421501CP	D123, D226
PS4106DP	D129	PS4120L31DP	D89	PS4206DP	D129	PS4220L20DP	D92
PS4111	D134, D245	PS4120L40DP	D89	PS4211	D134, D245	PS4220L21DP	D92
PS411117 ...	D95, D119, D219	PS4120L41DP	D89	PS421110	D95, D119, D219	PS4220L30DP	D92
PS4111170CP	D113, D216	PS4120L60DP	D89			PS4220L31DP	D92
PS411117ACP	D88	PS4120L61DP	D89			PS4220L40DP	D92
PS411117CCP	D88	PS4120M20DP	D89				

Part Number Index
Safety Guide
Offer of Sale
Part Number Index, Safety Guide, Offer of Sale



For inventory, lead times, and kit lookup, visit www.pdnplu.com

Model No.	Section / Page No.	Model No.	Section / Page No.	Model No.	Section / Page No.	Model No.	Section / Page No.
PS4220L41DP	D92	PS551124	D104	PS5535P	D77	PS561162JP	D74
PS4220L60DP	D92	PS551153	D104	PS5536P	D130	PS561162MP	D74
PS4220L61DP	D92	PS5511530P	D102, D205	PS5537	D136, D242	PS561162NP	D74
PS4220M20DP	D92	PS551153CP	D76	PS5537155DXP	D205	PS561162PP	D74
PS4220M21DP	D92	PS551153JP	D76	PS5537155P	D102	PS5612P	D129, D214
PS4220M40DP	D92	PS551153MP	D76	PS5537166DXP	D205	PS561600P	D75
PS4220M41DP	D92	PS551153NP	D76	PS5537166P	D102	PS561601P	D75
PS4220T10DP	D92	PS551153PP	D76	PS5537255DXP	D205	PS561700P	D75
PS4220T11DP	D92	PS551154	D104	PS5537255P	D102	PS561701P	D75
PS4220T20DP	D92	PS5511540P	D102, D205	PS5537266DXP	D205	PS561AP	D75, D77, D101, D102, D214
PS4220T21DP	D92	PS551154CP	D76	PS5537266P	D102	PS561BP	D75, D77, D101, D102, D214
PS423101	D119	PS551154JP	D76	PS5538155P	D77	PS561CP	D75, D77, D101, D102, D214
PS4231010DP	D92, D116, D217	PS551154MP	D76	PS5538166P	D77	PS561DP	D75, D77, D101, D102, D214
PS4231011DP	D92, D116, D217	PS551154NP	D76	PS5538255P	D77		
PS4232CP	D92, D116, D226	PS551154PP	D76	PS5538266P	D77		
PS4234CP	D92, D116, D226	PS551163	D104	PS5542P	D102, D214	PS5620L20P	D78
PS4235CP	D92	PS5511630P	D102	PS5587P	D129	PS5620L21P	D78
PS4236P	D130	PS551163CP	D76	PS5601P	D129	PS5620L30P	D78
PS4237	D136, D221	PS551163JP	D76	PS5602P	D129	PS5620L31P	D78
PS4237166CP	D116, D217	PS551163MP	D76	PS5603P	D129	PS5620L40P	D78
PS4237266CP	D116, D217	PS551163NP	D76	PS5604P	D129	PS5620L41P	D78
PS4238	D98, D136	PS551163PP	D76	PS5605P	D129	PS5620L50P	D78
PS4238166CP	D92	PS551164	D104	PS5611	D207, D242	PS5620L51P	D78
PS4238266CP	D92	PS5511640P	D102	PS561151	D104	PS5620L60P	D78
PS4240P	D130	PS551164CP	D76	PS5611510P	D101, D204	PS5620L61P	D78
PS4242CP	D116, D226	PS551164JP	D76	PS561151JP	D74	PS5620M20P	D78
PS4287DP	D129	PS551164MP	D76	PS561151MP	D74	PS5620M21P	D78
PS42D3DP	D129	PS551164NP	D76	PS561151NP	D74	PS5620M40P	D78
PS42D5DP	D129	PS551164PP	D76	PS561151PP	D74	PS5620M41P	D78
PS5501P	D129	PS5512P	D129, D214	PS561152	D104	PS5620T10P	D78
PS5502P	D129	PS551500P	D123, D205, D209	PS5611520P	D101, D204	PS5620T11P	D78
PS5503P	D129	PS551501P	D123, D205, D209	PS561152JP	D74	PS5620T20P	D78
PS5504P	D129	PS551600P	D77	PS561152MP	D74	PS5620T21P	D78
PS5505P	D129	PS551601P	D77	PS561152NP	D74	PS562401*P	D107
PS5511	D207, D242	PS551700P	D77	PS561152PP	D74	PS5624L20P	D78
PS551113	D104	PS551701P	D77	PS561161	D104	PS5624L21P	D78
PS551113CP	D76	PS552600P	D205	PS5611610P	D101	PS5624L30P	D78
PS551114	D104	PS552601P	D205	PS561161JP	D74	PS5624L31P	D78
PS551114CP	D76	PS552700P	D205	PS561161MP	D74	PS5624L40P	D78
PS551123	D104	PS552701P	D205	PS561161NP	D74	PS5624L41P	D78
		PS5531011P	D205	PS561161PP	D74	PS5624L50P	D78
		PS5534P	D77, D214	PS561162	D104	PS5624L51P	D78

Part Number Index

Safety Guide

Offer of Sale

Part Number Index, Safety Guide, Offer of Sale



For inventory, lead time, and kit lookup, visit www.pdnplu.com

Model No.	Section / Page No.	Model No.	Section / Page No.	Model No.	Section / Page No.	Model No.	Section / Page No.
PS5624L60P	D78	PS567904	D9, D26	PSM0013	D12, D26	PSMM75AP	D5
PS5624L61P	D78	PS567906	D9, D26	PSM0014	D12	PSMM76AP	D5
PS5624M20P	D78	PS567925	D9, D10, D11, D26	PSM0022	D12	PSMRAX6AP	D9
PS5624M21P	D78	PS568204	D9, D26	PSM0025	D12	PSMT11AP	D5
PS5624M40P	D78	PS568206	D9, D26	PSM002E	D12	PSMT12AP	D5
PS5624M41P	D78	PS568215	D9, D26	PSM002N	D12	PSMT15AP	D5
PS5624P	D130	PS568225	D9, D26	PSM002P	D12	PSMT16AP	D5
PS5624T10P	D78	PS568308	D9, D27	PSM002Q	D12	PSMT21AP	D5
PS5624T11P	D78	PS568310	D9, D27	PSM21JAP	D4, D9, D10, D11	PSMT22AP	D5
PS5624T20P	D78	PS568325	D9, D27	PSM21MAP	D4, D10, D11	PSMT25AP	D5
PS5624T21P	D78	PS568338	D9, D10, D11, D27	PSM22JAP	D4	PSMT26AP	D5
PS562600P	D101, D102, D204	PS5687P	D129	PSM22MAP	D4	PSMXN##NP	B6
PS562601P	D101, D102, D204	PS5706	D12	PSM3BXG##NP	C49	PSPE701-2G	F38
PS562700P	D101, D102, D204	PSBJ708-2G	F38	PSM3BXN##NP	C49	PSPE701-4G	F38
PS562701P	D101, D102, D204	PSBJ708-4G	F38	PSM5BXG##NP	C49	PSPE701-6G	F38
PS5631010P	D78, D101, D102, D204, D205	PSBJ731-0	F38	PSM5BXN##NP	C49	PSPE701-8G	F38
PS5631011P	D78, D101, D102, D204	PSBJ731-2	F38	PSM6BXG##NP	C49	PSPE701-M5	F38
PS5632P	D130	PSBJ731-2G	F38	PSM6BXN##NP	C49	PSPJ731-2	F38
PS5634P	D75, D101, D102, D214	PSBJ731-4	F38	PSM7BXG##NP	C49	PSPJ731-4	F38
PS5635P	D75	PSBJ731-4G	F38	PSM7BXN##NP	C49	PSPJ731-6	F38
PS5636P	D130	PSBJ731-6	F38	PSML21AP	D5	PSSCCNA	D150, D157, D162, D163
PS5637	D136, D242	PSBJ731-6G	F38	PSML22AP	D5	PSSCDM12A	D11, D150, D157, D162, D163
PS5637155DXP	D204	PSBJ731-8	F38	PSML25AP	D5, D9	PSSCDM18PA	D150, D157, D162, D163
PS5637155P	D101	PSBJ731-8G	F38	PSML26AP	D5	PSSCDM18PA	D150, D157, D162, D163
PS5637166DXP	D204	PSBJ731-M5	F38	PSML61AP	D5	PSSCENA	D150, D157, D162, D163
PS5637166P	D101	PSG 3M-*/S90	D184	PSML62AP	D5	PSSCPBA	D150, D157, D162, D163
PS5637255DXP	D204	PSG3BXG##NP	C49	PSML65AP	D5	PSSEXT1	D152, D153
PS5637255P	D101	PSG3BXN##NP	C49	PSML66AP	D5	PSSEXT3	D152
PS5637266DXP	D204	PSG5BXG##NP	C49	PSMM41AP	D5	PSSN16M12	D150
PS5637266P	D101	PSG5BXN##NP	C49	PSMM42AP	D5	PSSN16M12A	D155, D163
PS5638155P	D75	PSG6BXG##NP	C49	PSMM45AP	D5, D10	PSSN16xxx	D162
PS5638166P	D75	PSG6BXN##NP	C49	PSMM46AP	D5	PSSN8M12A	D11, D150, D155, D163
PS5638255P	D75	PSJ3B1G##NP	C50	PSMM51AP	D5	PSSN8M23A	D150, D155, D163
PS5638266P	D75	PSJ3B1N##NP	C50	PSMM52AP	D5	PSSN8M8A	D150, D155, D163
PS5642P	D101, D214	PSM0001	D12	PSMM55AP	D5, D11	PSSN8xxx	D162
PS5651160P	D75, D77, D101, D102, D204, D205	PSM0002	D12	PSMM56AP	D5	PSSNACM12A	D151, D156, D162, D163
PS567900	D26	PSM0003	D12	PSMM61AP	D5	PSSNAVM12A	D151, D156, D162, D163
		PSM0004	D12	PSMM62AP	D5		
		PSM0004	D12	PSMM65AP	D5, D11		
		PSM001*	D26	PSMM66AP	D5		
		PSM0010	D12	PSMM71AP	D5		
		PSM0011	D12	PSMM72AP	D5		
		PSM0012	D12				

Part Number Index
Safety Guide
Offer of Sale
Part Number Index, Safety Guide, Offer of Sale



For inventory, lead times, and kit lookup, visit www.pdnplu.com

Model No.	Section / Page No.	Model No.	Section / Page No.	Model No.	Section / Page No.	Model No.	Section / Page No.
PSPP8M12A	D150, D155, D163	PWBA1469/3469	F21	PXBB3211BD3.....	E69	PXCK22106	E78
PSPP8xxx	D162	PWBA1483	F17, F21	PXBB3211BJ5	E69	PXCK22121	E78
PSSSE24	D157	PWBA1489	F17, F21	PXBB3251BA2.....	E69	PXCM111.....	E77
PSSSE24A	D152, D153, D154, D158, D159, D162, D163	PWBA1493	F17	PXBB3251BD2.....	E69	PXCM115.....	E77
PSST16D25A.....	D151, D155, D163	PWBA1493/3493	F21	PXBB3251BD3.....	E69	PXCM121.....	E77
PSST16M12A	D151, D155, D163	PWBA1822	F17	PXBB3911	E71	PXCM125.....	E77
PSST16M223A	D155	PWBA1822/3822	F21	PXBB3912	E71	PXCM521.....	E77
PSST16M23A	D151, D163	PWBA1833	F17	PXBB3921	E71	PXCM601A102	E78
PSST16xxx.....	D162	PWBA1833/3833	F21	PXBB3922	E71	PXCM601A103	E78
PSST8M12A	D151, D155, D163	PWBA1898	F17	PXB-B4	E76	PXCM601A110	E78
PSST8M23A	D151, D155, D163	PWBA1898/3888	F21	PXBB4131B.....	E71	PXCZ11.....	E77
PSST8M8A	D151, D155, D163	PWBA1899	F17	PXBB4131BA2.....	E69	PXPA11	E61
PSST8xxx.....	D162	PWBA1899/3899	F21	PXBB4131BA3.....	E69	PXPC111	E61
PSSTACM12A.....	D151, D156, D162, D163	PWBA3412	F17	PXBB4131BA4.....	E69	PXVF111	E73
PSSTAVM12A.....	D151, D156, D162, D163	PWBA3468	F17	PXBB4131BC2	E69	PXVF1211	E73
PSSTERM	D151	PWBA3469	F17	PXBB4131BD2.....	E69	PXVF1213	E73
PSSTR4M12A.....	D151, D155, D163	PWBA3493	F17	PXBB4131BT4	E69	PXVF1214	E73
PSSTR4MRA.....	D162	PWBA3822	F17	PXBB4231BA2.....	E69	PXVF1215	E73
PSSV32A	D130, D157, D162, D163	PWBA38227	F17, F21	PXBB4231BD2.....	E69	PXVF1216	E73
PSSVEXT1	D11, D152, D154	PWBA3833	F17	PXBB4231BD3.....	E69	PXVF131	E73
PSSVM32A	D157, D162, D163	PWBA38337	F17, F21	PXBB4231BJ5	E69	PXVF141	E73
PSXM2186P.....	B6	PWBA3888	F17	PXBB4931	E71	PXVF151	E73
PSXM31010P.....	B6	PWBA38887	F17, F21	PXBB4932	E71	PXVF161	E73
PSXM40900P.....	B6	PWBA3899	F17	PXCJ117	E80	RKC 4.4T*	C26
PSXM530CP	B6	PWBA38997	F17, F21	PXCJ11701.....	E80	RKC 4.4T*-RSC 4.4T.....	D184
PSXM8100P.....	B6	PWSB1227	F19, F21	PXCJ11705.....	E80	RKC 4.4T-1	D184
PSXM8288P.....	B6	PWSB1337	F19, F21	PXCJ127	E80	RKC 4.5T*/S1587.....	D184
PSXM8310P.....	B6	PWSB1557	F19, F21	PXCJ12701	E80	RKC 4.5T*-RSC 4.5T/S1587 ..	D184
PWBA1412	F17	PWSB1887	F19, F21	PXCJ12705.....	E80	RKM 46-5M/S1587	D184
PWBA1412/3412	F21	PWSB1997	F19, F21	PXCK211	E79	RKM 56-5M/S1587	D184
PWBA1468	F17	PWSM1012.....	F19, F21	PXCK21100	E79	RSC 4.4T-	D184
PWBA1468/3468	F21	PWSP111	F19, F21	PXCK2110031	E79	RSC 4.5T*/S1587.....	D184
PWBA1469	F17	PXB-B3.....	E76	PXCK2110041	E79	RSC RKC 5711-xM.....	D186
		PXBB3111B.....	E61, E71	PXCK21101	E78	RSC RKM 5711-xM.....	D186
		PXBB3111BA2.....	E69	PXCK21102	E78	RSM 57-TR2	D186
		PXBB3111BA3.....	E69	PXCK21106	E78	RSM RKC 5711-xM.....	D186
		PXBB3111BA4.....	E69	PXCK21121	E78	RSM RKM 46-x/S1587....	D184
		PXBB3111BC2	E69	PXCK21121	E78	RSM RKM 56-x/S1587....	D184
		PXBB3111BD2.....	E69	PXCK221	E79	RSM RKM 57 WSM 40 PST	D186
		PXBB3111BT4	E69	PXCK22100	E79	RSM RKM 5711-xM.....	D186
		PXBB3121B.....	E71	PXCK2210031	E79	RSM-2RKM 40.....	D184
		PXBB3121BT4	E69	PXCK22101	E78		
		PXBB3211BD2.....	E69	PXCK22102	E78		

Part Number Index

Safety Guide

Offer of Sale

Part Number Index, Safety Guide, Offer of Sale



For inventory, lead time, and kit lookup, visit www.pdnplu.com

Model No.	Section / Page No.	Model No.	Section / Page No.	Model No.	Section / Page No.	Model No.	Section / Page No.
RSM-2RKM 50.....	D184	XM30NBG49A.....	B3	ZB4BJ4.....	E70	ZBY2326.....	E72
RSSD RJ45S 443-2M.....	D185	XM30NBG53A.....	B3	ZB4BJ5.....	E70	ZBY2327.....	E72
RSSD RKSD 443-xM.....	D185	XM30NBH49A.....	B3	ZB4BL2.....	E70	ZBY2328.....	E72
RSSW RKSW 455-xM.....	D185	XM30NBH53A.....	B3	ZB4BL3.....	E70	ZBY2330.....	E72
S421159.....	D219	XM3VNB549A.....	B3	ZB4BL4.....	E70	ZBY2334.....	E72
SCD253W.....	D12, D42, D46, D125, D185	XM3VNB553A.....	B3	ZB4BL5.....	E70	ZBY2367.....	E72
SCD259D.....	D12, D42, D46, D125, D185	XM3VNBG49A.....	B3	ZB4BP2.....	E70	ZBY2387.....	E72
SCD259D.....	D12, D42, D46, D125, D185	XM3VNBG53A.....	B3	ZB4BP3.....	E70	ZBY4101.....	E72
SCD259WE.....	D12, D42, D46, D125, D185	XM40NB549A.....	B3	ZB4BP4.....	E70	ZBZ1602.....	E73
VL25.....	E62	XM40NB553A.....	B3	ZB4BR.....	E61	ZC2JE01.....	E80
VL37.....	E62	XM40NBG49A.....	B3	ZB4BR2.....	E70	ZC2JE02.....	E80
VL50.....	E62	XM40NBG53A.....	B3	ZB4BR3.....	E70	ZC2JE03.....	E80
VLA25.....	E62	XM40NBH49A.....	B3	ZB4BR4.....	E70	ZC2JE05.....	E80
VLA37.....	E62	XM40NBH53A.....	B3	ZB4BS844.....	E70	ZC2JE09.....	E80
VLA50.....	E62	XM4VNB549A.....	B3	ZB4BS944.....	E70	ZC2JE61.....	E80
VLD25.....	E62	XM4VNB553A.....	B3	ZB4BT2.....	E70	ZC2JE62.....	E80
VLD37.....	E62	XM4VNBG49A.....	B3	ZB4BZ009.....	E70	ZC2JE63.....	E80
VLD50.....	E62	XM4VNBG53A.....	B3	ZB5AA2.....	E70	ZC2JE70.....	E80
W68PLCK-4-2.....	F35	ZB2BY2002.....	E72	ZB5AA3.....	E70	ZC2JY11.....	E80
W68PLCK-4-4.....	F35	ZB4BA2.....	E70	ZB5AA4.....	E70	ZC2JY13.....	E80
W68PLCK-5/32-2.....	F35	ZB4BA3.....	E70	ZB5AL2.....	E70	ZC2JY21.....	E80
W68PLCK-6-4.....	F35	ZB4BA4.....	E70	ZB5AL3.....	E70	ZC2JY31.....	E80
W68PLCK-6-6.....	F35	ZB4BA5.....	E70	ZB5AL4.....	E70	ZC2JY41.....	E80
W68PLCKI-4-2.....	F35	ZB4BA6.....	E70	ZB5AZ009.....	E70	ZC2JY61.....	E80
W68PLCKI-4-4.....	F35	ZB4BC2.....	E70	ZB5AZ905.....	E73	ZC2JY71.....	E80
W68PLCKI-5/32-2.....	F35	ZB4BC3.....	E70	ZBE101.....	E72	ZC2JY81.....	E80
W68PLCKI-6-4.....	F35	ZB4BC4.....	E70	ZBE102.....	E72	ZC2JY91.....	E80
W68PLCKI-6-6.....	F35	ZB4BD2.....	E70	ZBY2002.....	E72	ZCKD02.....	E80
WKM 46-5M/S1587.....	D184	ZB4BD3.....	E70	ZBY2101.....	E72	ZCKD06.....	E80
WKM 56-5M/S1587.....	D184	ZB4BD4.....	E70	ZBY2303.....	E72	ZCKD10.....	E80
WPASV13000-AA-34.....	C80	ZB4BD5.....	E70	ZBY2304.....	E72	ZCKD21.....	E80
WPASV13000-AA-94.....	C80	ZB4BD7.....	E70	ZBY2305.....	E72	ZCKD23.....	E80
WPASV15000-AA-42.....	C81	ZB4BD8.....	E70	ZBY2306.....	E72	ZCKG00.....	E80
WPASV15000-AA-92.....	C81	ZB4BG2.....	E70	ZBY2307.....	E72	ZCKY11.....	E80
WPASV2000-AA-17.....	C78	ZB4BG3.....	E70	ZBY2308.....	E72	ZCKY13.....	E80
WPASV2000-AA-97.....	C78	ZB4BG4.....	E70	ZBY2309.....	E72	ZCKY41.....	E80
WPASV200-AA-M5.....	C77	ZB4BG5.....	E70	ZBY2310.....	E72	ZCKY43.....	E80
WPASV5000-AA-21.....	C79	ZB4BG7.....	E70	ZBY2311.....	E72	ZCKY51.....	E80
WPASV5000-AA-91.....	C79	ZB4BH02.....	E70	ZBY2312.....	E72	ZCKY52.....	E80
XM30NB49A.....	B3	ZB4BH03.....	E70	ZBY2313.....	E72	ZCKY81.....	E80
XM30NB549A.....	B3	ZB4BH04.....	E70	ZBY2314.....	E72	ZCKY91.....	E80
XM30NB553A.....	B3	ZB4BJ2.....	E70	ZBY2321.....	E72		
		ZB4BJ3.....	E70	ZBY2323.....	E72		

Part Number Index

Safety Guide

Offer of Sale

Part Number Index, Safety Guide, Offer of Sale



For inventory, lead times, and kit lookup, visit www.pdnplu.com

Safety Guide For Selecting And Using Pneumatic Division Products And Related Accessories

WARNING:

FAILURE OR IMPROPER SELECTION OR IMPROPER USE OF PNEUMATIC DIVISION PRODUCTS, ASSEMBLIES OR RELATED ITEMS ("PRODUCTS") CAN CAUSE DEATH, PERSONAL INJURY, AND PROPERTY DAMAGE. POSSIBLE CONSEQUENCES OF FAILURE OR IMPROPER SELECTION OR IMPROPER USE OF THESE PRODUCTS INCLUDE BUT ARE NOT LIMITED TO:

- Unintended or mistimed cycling or motion of machine members or failure to cycle
- Work pieces or component parts being thrown off at high speeds.
- Failure of a device to function properly for example, failure to clamp or unclamp an associated item or device.
- Explosion
- Suddenly moving or falling objects.
- Release of toxic or otherwise injurious liquids or gasses.

Before selecting or using any of these Products, it is important that you read and follow the instructions below.

1. GENERAL INSTRUCTIONS

- 1.1. Scope:** This safety guide is designed to cover general guidelines on the installation, use, and maintenance of Pneumatic Division Valves, FRLs (Filters, Pressure Regulators, and Lubricators), Vacuum products and related accessory components.
- 1.2. Fail-Safe:** Valves, FRLs, Vacuum products and their related components can and do fail without warning for many reasons. Design all systems and equipment in a fail-safe mode, so that failure of associated valves, FRLs or Vacuum products will not endanger persons or property.
- 1.3. Relevant International Standards:** For a good guide to the application of a broad spectrum of pneumatic fluid power devices see: ISO 4414:1998, Pneumatic Fluid Power – General Rules Relating to Systems. See www.iso.org for ordering information.
- 1.4. Distribution:** Provide a copy of this safety guide to each person that is responsible for selection, installation, or use of Valves, FRLs or Vacuum products. Do not select, or use Parker valves, FRLs or vacuum products without thoroughly reading and understanding this safety guide as well as the specific Parker publications for the products considered or selected.
- 1.5. User Responsibility:** Due to the wide variety of operating conditions and applications for valves, FRLs, and vacuum products Parker and its distributors do not represent or warrant that any particular valve, FRL or vacuum product is suitable for any specific end use system. This safety guide does not analyze all technical parameters that must be considered in selecting a product. The user, through its own analysis and testing, is solely responsible for:
 - Making the final selection of the appropriate valve, FRL, Vacuum component, or accessory.
 - Assuring that all user's performance, endurance, maintenance, safety, and warning requirements are met and that the application presents no health or safety hazards.
 - Complying with all existing warning labels and / or providing all appropriate health and safety warnings on the equipment on which the valves, FRLs or Vacuum products are used; and,
 - Assuring compliance with all applicable government and industry standards.
- 1.6. Safety Devices:** Safety devices should not be removed, or defeated.
- 1.7. Warning Labels:** Warning labels should not be removed, painted over or otherwise obscured.
- 1.8. Additional Questions:** Call the appropriate Parker technical service department if you have any questions or require any additional information. See the Parker publication for the product being considered or used, or call 1-800-CPARKER, or go to www.parker.com, for telephone numbers of the appropriate technical service department.

2. PRODUCT SELECTION INSTRUCTIONS

- 2.1. Flow Rate:** The flow rate requirements of a system are frequently the primary consideration when designing any pneumatic system. System components need to be able to provide adequate flow and pressure for the desired application.
- 2.2. Pressure Rating:** Never exceed the rated pressure of a product. Consult product labeling, Pneumatic Division catalogs or the instruction sheets supplied for maximum pressure ratings.
- 2.3. Temperature Rating:** Never exceed the temperature rating of a product. Excessive heat can shorten the life expectancy of a product and result in complete product failure.
- 2.4. Environment:** Many environmental conditions can affect the integrity and suitability of a product for a given application. Pneumatic Division products are designed for use in general purpose industrial applications. If these products are to be used in unusual circumstances such as direct sunlight and/or corrosive or caustic environments, such use can shorten the useful life and lead to premature failure of a product.
- 2.5. Lubrication and Compressor Carryover:** Some modern synthetic oils can and will attack nitrile seals. If there is any possibility of synthetic oils or greases migrating into the pneumatic components check for compatibility with the seal materials used. Consult the factory or product literature for materials of construction.
- 2.6. Polycarbonate Bowls and Sight Glasses:** To avoid potential polycarbonate bowl failures:
 - Do not locate polycarbonate bowls or sight glasses in areas where they could be subject to direct sunlight, impact blow, or temperatures outside of the rated range.
 - Do not expose or clean polycarbonate bowls with detergents, chlorinated hydro-carbons, ketones, esters or certain alcohols.
 - Do not use polycarbonate bowls or sight glasses in air systems where compressors are lubricated with fire resistant fluids such as phosphate ester and di-ester lubricants.

Part Number
Index

Safety
Guide

Offer of
Sale

Part Number Index,
Safety Guide, Offer of Sale



For inventory, lead time, and kit lookup, visit www.pdnplu.com

G27

Parker Hannifin Corporation
Pneumatic Division
Richland, Michigan
www.parker.com/pneumatics

2.7. Chemical Compatibility: For more information on plastic component chemical compatibility see Pneumatic Division technical bulletins Tec-3, Tec-4, and Tec-5

2.8. Product Rupture: Product rupture can cause death, serious personal injury, and property damage.

- Do not connect pressure regulators or other Pneumatic Division products to bottled gas cylinders.
- Do not exceed the maximum primary pressure rating of any pressure regulator or any system component.
- Consult product labeling or product literature for pressure rating limitations.

3. PRODUCT ASSEMBLY AND INSTALLATION INSTRUCTIONS

3.1. Component Inspection: Prior to assembly or installation a careful examination of the valves, FRLs or vacuum products must be performed. All components must be checked for correct style, size, and catalog number. DO NOT use any component that displays any signs of nonconformance.

3.2. Installation Instructions: Parker published Installation Instructions must be followed for installation of Parker valves, FRLs and vacuum components. These instructions are provided with every Parker valve or FRL sold, or by calling 1-800-CPARKER, or at www.parker.com.

3.3. Air Supply: The air supply or control medium supplied to Valves, FRLs and Vacuum components must be moisture-free if ambient temperature can drop below freezing

4. VALVE AND FRL MAINTENANCE AND REPLACEMENT INSTRUCTIONS

4.1. Maintenance: Even with proper selection and installation, valve, FRL and vacuum products service life may be significantly reduced without a continuing maintenance program. The severity of the application, risk potential from a component failure, and experience with any known failures in the application or in similar applications should determine the frequency of inspections and the servicing or replacement of Pneumatic Division products so that products are replaced before any failure occurs. A maintenance program must be established and followed by the user and, at minimum, must include instructions 4.2 through 4.9.

4.2. Installation and Service Instructions: Before attempting to service or replace any worn or damaged parts consult the appropriate Service Bulletin for the valve or FRL in question for the appropriate practices to service the unit in question. These Service and Installation Instructions are provided with every Parker valve and FRL sold, or are available by calling 1-800-CPARKER, or by accessing the Parker web site at www.parker.com.

4.3. Lockout / Tagout Procedures: Be sure to follow all required lockout and tagout procedures when servicing equipment. For more information see: OSHA Standard – 29 CFR, Part 1910.147, Appendix A, The Control of Hazardous Energy – (Lockout / Tagout)

4.4. Visual Inspection: Any of the following conditions requires immediate system shut down and replacement of worn or damaged components:

- Air leakage: Look and listen to see if there are any signs of visual damage to any of the components in the system. Leakage is an indication of worn or damaged components.
- Damaged or degraded components: Look to see if there are any visible signs of wear or component degradation.
- Kinked, crushed, or damaged hoses. Kinked hoses can result in restricted air flow and lead to unpredictable system behavior.
- Any observed improper system or component function: Immediately shut down the system and correct malfunction.
- Excessive dirt build-up: Dirt and clutter can mask potentially hazardous situations.

Caution: Leak detection solutions should be rinsed off after use.

4.5. Routine Maintenance Issues:

- Remove excessive dirt, grime and clutter from work areas.
- Make sure all required guards and shields are in place.

4.6. Functional Test: Before initiating automatic operation, operate the system manually to make sure all required functions operate properly and safely.

4.7. Service or Replacement Intervals: It is the user's responsibility to establish appropriate service intervals. Valves, FRLs and vacuum products contain components that age, harden, wear, and otherwise deteriorate over time. Environmental conditions can significantly accelerate this process. Valves, FRLs and vacuum components need to be serviced or replaced on routine intervals. Service intervals need to be established based on:

- Previous performance experiences.
- Government and / or industrial standards.
- When failures could result in unacceptable down time, equipment damage or personal injury risk.

4.8. Servicing or Replacing of any Worn or Damaged Parts: To avoid unpredictable system behavior that can cause death, personal injury and property damage:

- Follow all government, state and local safety and servicing practices prior to service including but not limited to all OSHA Lockout Tagout procedures (OSHA Standard – 29 CFR, Part 1910.147, Appendix A, The Control of Hazardous Energy – Lockout / Tagout).
- Disconnect electrical supply (when necessary) before installation, servicing, or conversion.
- Disconnect air supply and depressurize all air lines connected to system and Pneumatic Division products before installation, service, or conversion.
- Installation, servicing, and / or conversion of these products must be performed by knowledgeable personnel who understand how pneumatic products are to be applied.
- After installation, servicing, or conversions air and electrical supplies (when necessary) should be connected and the product tested for proper function and leakage. If audible leakage is present, or if the product does not operate properly, do not put product or system into use.
- Warnings and specifications on the product should not be covered or painted over. If masking is not possible, contact your local representative for replacement labels.

4.9. Putting Serviced System Back into Operation: Follow the guidelines above and all relevant Installation and Maintenance Instructions supplied with the valve FRL or vacuum component to insure proper function of the system.



PARKER-HANNIFIN CORPORATION
OFFER OF SALE

1. **Definitions.** As used herein, the following terms have the meanings indicated.

Buyer:	means any customer receiving a Quote for Products from Seller.
Goods:	means any tangible part, system or component to be supplied by the Seller.
Products:	means the Goods, Services and/or Software as described in a Quote provided by the Seller.
Quote:	means the offer or proposal made by Seller to Buyer for the supply of Products.
Seller:	means Parker-Hannifin Corporation, including all divisions and businesses thereof.
Services:	means any services to be supplied by the Seller.
Software:	means any software related to the Products, whether embedded or separately downloaded.
Terms:	means the terms and conditions of this Offer of Sale or any newer version of the same as published by Seller electronically at www.parker.com/saleterms .

2. **Terms.** All sales of Products by Seller are contingent upon, and will be governed by, these Terms and, these Terms are incorporated into any Quote provided by Seller to any Buyer. Buyer's order for any Products whether communicated to Seller verbally, in writing, by electronic data interface or other electronic commerce, shall constitute acceptance of these Terms. Seller objects to any contrary or additional terms or conditions of Buyer. Reference in Seller's order acknowledgement to Buyer's purchase order or purchase order number shall in no way constitute an acceptance of any of Buyer's terms of purchase. No modification to these Terms will be binding on Seller unless agreed to in writing and signed by an authorized representative of Seller.

3. **Price; Payment.** The Products set forth in Seller's Quote are offered for sale at the prices indicated in Seller's Quote. Unless otherwise specifically stated in Seller's Quote, prices are valid for thirty (30) days and do not include any sales, use, or other taxes or duties. Seller reserves the right to modify prices at any time to adjust for any raw material price fluctuations. Unless otherwise specified by Seller, all prices are F.C.A. Seller's facility (INCOTERMS 2010). All sales are contingent upon credit approval and payment for all purchases is due thirty (30) days from the date of invoice (or such date as may be specified in the Quote). Unpaid invoices beyond the specified payment date incur interest at the rate of 1.5% per month or the maximum allowable rate under applicable law.

4. **Shipment; Delivery; Title and Risk of Loss.** All delivery dates are approximate. Seller is not responsible for damages resulting from any delay. Regardless of the manner of shipment, delivery occurs and title and risk of loss or damage pass to Buyer, upon placement of the Products with the shipment carrier at Seller's facility. Unless otherwise agreed, Seller may exercise its judgment in choosing the carrier and means of delivery. No deferment of shipment at Buyers' request beyond the respective indicated shipping date will be made except on terms that will indemnify, defend and hold Seller harmless against all loss and additional expense. Buyer shall be responsible for any additional shipping charges incurred by Seller due to Buyer's acts or omissions.

5. **Warranty.** The warranty related to the Products is as follows: (i) Goods are warranted against defects in material or workmanship for a period of twelve (12) months from the date of delivery or 2,000 hours of use, whichever occurs first; (ii) Services shall be performed in accordance with generally accepted practices and using the degree of care and skill that is ordinarily exercised and customary in the field to which the Services pertain and are warranted for a period of six (6) months from the completion of the Services by Seller; and (iii) Software is only warranted to perform in accordance with applicable specifications provided by Seller to Buyer for ninety (90) days from the date of delivery or, when downloaded by a Buyer or end-user, from the date of the initial download. All prices are based upon the exclusive limited warranty stated above, and upon the following disclaimer:

DISCLAIMER OF WARRANTY: THIS WARRANTY IS THE SOLE AND ENTIRE WARRANTY PERTAINING TO PRODUCTS. SELLER DISCLAIMS ALL OTHER WARRANTIES, EXPRESS AND IMPLIED, INCLUDING DESIGN, NONINFRINGEMENT, MERCHANTABILITY, AND FITNESS FOR A PARTICULAR PURPOSE. SELLER DOES NOT WARRANT THAT THE SOFTWARE IS ERROR-FREE OR FAULT-TOLERANT, OR THAT BUYER'S USE THEREOF WILL BE SECURE OR UNINTERRUPTED. BUYER AGREES AND ACKNOWLEDGES THAT UNLESS OTHERWISE AUTHORIZED IN WRITING BY SELLER THE SOFTWARE SHALL NOT BE USED IN CONNECTION WITH HAZARDOUS OR HIGH RISK ACTIVITIES OR ENVIRONMENTS. EXCEPT AS EXPRESSLY STATED HEREIN, ALL PRODUCTS ARE PROVIDED "AS IS".

6. **Claims; Commencement of Actions.** Buyer shall promptly inspect all Products upon receipt. No claims for shortages will be allowed unless reported to the Seller within ten (10) days of delivery. Buyer shall notify Seller of any alleged breach of warranty within thirty (30) days after the date the non-conformance is or should have been discovered by Buyer. Any claim or action against Seller based upon breach of contract or any other theory, including tort, negligence, or otherwise must be commenced within twelve (12) months from the date of the alleged breach or other alleged event, without regard to the date of discovery.

7. **LIMITATION OF LIABILITY.** IN THE EVENT OF A BREACH OF WARRANTY, SELLER WILL, AT ITS OPTION, REPAIR OR REPLACE THE NON-CONFORMING PRODUCT, RE-PERFORM THE SERVICES, OR REFUND THE PURCHASE PRICE PAID WITHIN A REASONABLE PERIOD OF TIME. IN NO EVENT IS SELLER LIABLE FOR ANY SPECIAL, INDIRECT, INCIDENTAL OR CONSEQUENTIAL DAMAGES ARISING OUT OF, OR AS THE RESULT OF, THE SALE, DELIVERY, NON-DELIVERY, SERVICING, NON-COMPLETION OF SERVICES, USE, LOSS OF USE OF, OR INABILITY TO USE THE PRODUCTS OR ANY PART THEREOF, LOSS OF DATA, IDENTITY, PRIVACY, OR CONFIDENTIALITY, OR FOR ANY CHARGES OR EXPENSES OF ANY NATURE INCURRED WITHOUT SELLER'S WRITTEN CONSENT, WHETHER BASED IN CONTRACT, TORT OR OTHER LEGAL THEORY. IN NO EVENT SHALL SELLER'S LIABILITY UNDER ANY CLAIM MADE BY BUYER EXCEED THE PURCHASE PRICE PAID FOR THE PRODUCTS.

8. **Loss to Buyer's Property.** Any designs, tools, patterns, materials, drawings, confidential information or equipment furnished by Buyer or any other items which are or become Buyer's property, will be considered obsolete and may be destroyed by Seller after two (2) consecutive years have elapsed without Buyer ordering the Products manufactured using such property. Seller shall not be responsible for any loss or damage to such property while it is in Seller's possession or control.

9. **Special Tooling.** Special Tooling includes but is not limited to tooling, jigs, fixtures and associated manufacturing equipment acquired or necessary to manufacture Products. A tooling charge may be imposed for any Special Tooling. Such Special Tooling shall be and remain Seller's property notwithstanding payment of any charges by Buyer. In no event will Buyer acquire any interest in Special Tooling belonging to Seller that is utilized in the manufacture of the Products, even if such Special Tooling has been specially converted or adapted for such manufacture and notwithstanding any charges paid by Buyer. Unless otherwise agreed, Seller has the right to alter, discard or otherwise dispose of any Special Tooling or other property in its sole discretion at any time.

10. **Security Interest.** To secure payment of all sums due, Seller retains a security interest in all Products delivered to Buyer and, Buyer's acceptance of these Terms is deemed to be a Security Agreement under the Uniform Commercial Code. Buyer authorizes Seller as its attorney to execute and file on Buyer's behalf all documents Seller deems necessary to perfect its security interest.

11. **User Responsibility.** The Buyer through its own analysis and testing, is solely responsible for making the final selection of the Products and assuring that all performance, endurance, maintenance, safety and warning requirements of the application of the Products are met. The Buyer must analyze all aspects of the application and follow applicable industry standards, specifications, and other technical information provided with the Product. If Seller provides Product options based upon data or specifications provided by the Buyer, the Buyer is responsible for determining that such data and specifications are suitable and sufficient for all applications and reasonably foreseeable uses of the Products. In the event the Buyer is not the end-user, Buyer will ensure such end-user complies with this paragraph.

12. **Use of Products; Indemnity by Buyer.** Buyer shall comply with all instructions, guides and specifications provided by Seller with the Products. **Unauthorized Uses.** If Buyer uses or resells the Products for any uses prohibited in Seller's instructions, guides or specifications, or Buyer otherwise fails to comply with Seller's instructions, guides and specifications, Buyer acknowledges that any such use, resale, or non-compliance is at Buyer's sole risk. Buyer shall indemnify, defend, and hold Seller harmless from any losses, claims, liabilities, damages, lawsuits, judgments and costs (including attorney fees and defense costs), whether for personal injury, property damage, intellectual property infringement or any other claim, brought by or incurred by Buyer, Buyer's employees, or any other person, arising out of: (a) improper selection, application, design, specification or other misuse of Products provided by Seller; (b) any act or omission, negligent or otherwise, of Buyer; (c) Seller's use of patterns, tooling, equipment, plans, drawings, designs or specifications or other information or things furnished by Buyer; (d) damage to the Products from an external cause, repair or attempted repair by anyone other than Seller, failure to follow instructions, guides and specifications provided by Seller, use with goods not provided by Seller, or opening, modifying, deconstructing or tampering with the Products for any reason; or (e) Buyer's failure to comply with these Terms. Seller shall not indemnify Buyer under any circumstance except as otherwise provided in these Terms.

13. **Cancellations and Changes.** Buyer may not cancel or modify any order for any reason, except with Seller's written consent and upon terms that will indemnify, defend and hold Seller harmless against all direct, incidental and consequential loss or damage. Seller, at any time, may change Product features, specifications, designs and availability.

14. **Limitation on Assignment.** Buyer may not assign its rights or obligations without the prior written consent of Seller.

15. **Force Majeure.** Seller does not assume the risk and is not liable for delay or failure to perform any of Seller's obligations by reason of events or circumstances beyond its reasonable control ("Events of Force Majeure"). Events of Force Majeure shall include without limitation: accidents, strikes or labor disputes, acts of any government or government agency, acts of nature, delays or failures in delivery from carriers or suppliers, shortages of materials, or any other cause beyond Seller's reasonable control.

16. **Waiver and Severability.** Failure to enforce any provision of these Terms will not invalidate that provision; nor will any such failure prejudice Seller's right to enforce that provision in the future. Invalidation of any provision of these Terms by legislation or other rule of law shall not invalidate any other provision herein and, the remaining provisions will remain in full force and effect.

17. **Termination.** Seller may terminate any agreement governed by or arising from these Terms for any reason and at any time by giving Buyer thirty (30) days prior written notice. Seller may immediately terminate, in writing, if Buyer: (a) breaches any provision of these Terms (b) appoints a trustee, receiver or custodian for all or any part of Buyer's property (c) files a petition for relief in bankruptcy on its own behalf, or one filed by a third party (d) makes an assignment for the benefit of creditors; or (e) dissolves its business or liquidates all or a majority of its assets.

18. **Ownership of Software.** Seller retains ownership of all Software supplied to Buyer hereunder. In no event shall Buyer obtain any greater right in and to the Software than a right in the nature of a license limited to the use thereof and subject to compliance with any other terms provided with the Software.

19. **Indemnity for Infringement of Intellectual Property Rights.** Seller is not liable for infringement of any patents, trademarks, copyrights, trade dress, trade secrets or similar rights ("Intellectual Property Rights") except as provided in this Section. Seller will defend at its expense and will pay the cost of any settlement or damages awarded in an action brought against Buyer based on a third party claim that one or more of the Products sold hereunder infringes the Intellectual Property Rights of a third party in the country of delivery of the Products by the Seller to the Buyer. Seller's obligation to defend and indemnify Buyer is contingent on Buyer notifying Seller within ten (10) days after Buyer becomes aware of any such claim, and Seller having sole control over the defense of the claim including all negotiations for settlement or compromise. If one or more Products sold hereunder is subject to such a claim, Seller may, at its sole expense and option, procure for Buyer the right to continue using the Products, replace or modify the Products so as to render them non-infringing, or offer to accept return of the Products and refund the purchase price less a reasonable allowance for depreciation. Seller has no obligation or liability for any claim of infringement: (i) arising from information provided by Buyer; or (ii) directed to any Products provided hereunder for which the designs are specified in whole or part by Buyer; or (iii) resulting from the modification, combination or use in a system of any Products provided hereunder. The foregoing provisions of this Section constitute Seller's sole and exclusive liability and Buyer's sole and exclusive remedy for such claims of infringement of Intellectual Property Rights.

20. **Governing Law.** These Terms and the sale and delivery of all Products are deemed to have taken place in, and shall be governed and construed in accordance with, the laws of the State of Ohio, as applicable to contracts executed and wholly performed therein and without regard to conflicts of laws principles. Buyer irrevocably agrees and consents to the exclusive jurisdiction and venue of the courts of Cuyahoga County, Ohio with respect to any dispute, controversy or claim arising out of or relating to the sale and delivery of the Products.

21. **Entire Agreement.** These Terms, along with the terms set forth in the main body of any Quote, forms the entire agreement between the Buyer and Seller and constitutes the final, complete and exclusive expression of the terms of sale. In the event of a conflict between any term set forth in the main body of a Quote and these Terms, the terms set forth in the main body of the Quote shall prevail. All prior or contemporaneous written or oral agreements or negotiations with respect to the subject matter shall have no effect. These Terms may not be modified unless in writing and signed by an authorized representative of Seller.

22. **Compliance with Laws.** Buyer agrees to comply with all applicable laws, regulations, and industry and professional standards, including those of the United States of America, and the country or countries in which Buyer may operate, including without limitation the U.S. Foreign Corrupt Practices Act ("FCPA"), the U.S. Anti-Kickback Act ("Anti-Kickback Act"), U.S. and E.U. export control and sanctions laws ("Export Laws"), the U.S. Food Drug and Cosmetic Act ("FDCA"), and the rules and regulations promulgated by the U.S. Food and Drug Administration ("FDA"), each as currently amended. Buyer agrees to indemnify, defend, and hold harmless Seller from the consequences of any violation of such laws, regulations and standards by Buyer, its employees or agents. Buyer acknowledges that it is familiar with all applicable provisions of the FCPA, the Anti-Kickback Act, Export Laws, the FDCA and the FDA and certifies that Buyer will adhere to the requirements thereof and not take any action that would make Seller violate such requirements. Buyer represents and agrees that Buyer will not make any payment or give anything of value, directly or indirectly, to any governmental official, foreign political party or official thereof, candidate for foreign political office, or commercial entity or person, for any improper purpose, including the purpose of influencing such person to purchase Products or otherwise benefit the business of Seller. Buyer further represents and agrees that it will not receive, use, service, transfer or ship any Product from Seller in a manner or for a purpose that violates Export Laws or would cause Seller to be in violation of Export Laws.

Parker Hannifin Corporation

Pneumatic Division

8676 E. M89

P.O. Box 901

Richland, MI 49083 USA

Tel: 269 629 5000

Fax: 269 629 5385

Applications Engineering

Phone: 877 321 4PDN Option #2

E-mail: pdnapps@parker.com

Customer Support

Phone: 877 321 4PDN Option #1

E-mail: pdncustsvc@parker.com

Web site: www.parker.com/pneumatics

